

Agilent 87606B Coaxial Matrix Switch DC to 20 GHz

Technical Overview

High Performance Matrix Switch for RF and Microwave Test Systems

- 3 x 3, 2 x 4, and 1 x 5 blocking matrix configurations
- Magnetic latching
- Make-before-break or break-before-make operation
- Operating life of 10 million cycles typical
- Guaranteed repeatability of 0.03 dB up to 5 million cycles
- Excellent isolation, typically > 100 dB at 20 GHz
- Terminated ports
- Self-interrupting drive circuit
- Fully compatible with Agilent 87130A/70611A switch drivers

Modern automated test systems demand higher accuracy and performance than ever before. The Agilent Technologies 87606B matrix switch offers improvements in insertion loss repeatability and isolation necessary to achieve higher test system performance. Long life, excellent repeatability, and high reliability lowers the cost of ownership by reducing calibration cycles and increasing test system uptime and are vital to ATS measurement system integrity.

Description

The 87606B matrix switch provides the life and reliability required for automated test and measurement, signal monitoring, and routing applications. Innovative design and careful process control creates a switch that meets the requirements for highly repeatable switching elements in test instruments and switching interfaces. The switch is designed to operate for more than 10 million cycles and will meet all electrical specifications for at least 5 million cycles.

The switch exhibits exceptional insertion loss repeatability. This reduces sources of random errors in the measurement path and improves measurement uncertainty. Switch life is a critical consideration in production test systems, satellite and antenna monitoring systems, and test instrumentation. The longevity of the switch increases system uptime, and lowers the cost of ownership by reducing calibration cycles and switch maintenance.

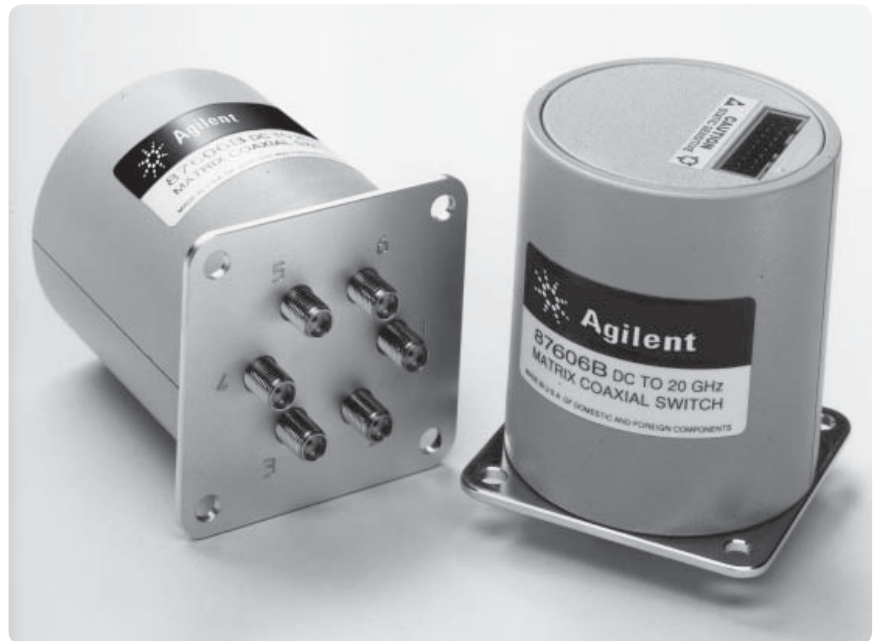

Agilent Technologies

Operating to 20 GHz, this switch exhibits the exceptional isolation performance required to maintain measurement integrity. Isolation between ports is typically > 100 dB to 20 GHz. This reduces the influence of signals from other channels, sustains the integrity of the measured signal, and reduces system measurement uncertainties. This switch also minimizes measurement uncertainty with low insertion loss and reflection, which makes it an ideal element in large, multi-tiered switching systems.

The 87606B is designed to fall within most popular industry footprints. The 2¼ inch square flange provides

mounting holes, while the rest of the 2½ inch long by 2¼ inch diameter body will easily fit into most systems. Ribbon cable or optional solder terminal connections accommodate the need for secure and efficient control cable attachment.

Option 100 provides solder terminal connections in place of the 16-pin ribbon drive cable. Option 100 does not incorporate the “open all ports” feature.

Each port is individually controlled by its corresponding “close” and “open” control lines. A port is closed or open when its corresponding “close” or “open” pin is connected to ground.

At this point, the current to the solenoids is shut off by the opto-electronic interrupts. This improves reliability and extends the life of the switch by eliminating dc circuit contact failures characteristic of conventional electromechanical switches. Full position sensing capability is assured when used with the Agilent 87130A/70611A switch drivers.

All unselected RF ports are terminated with 50 ohm loads.

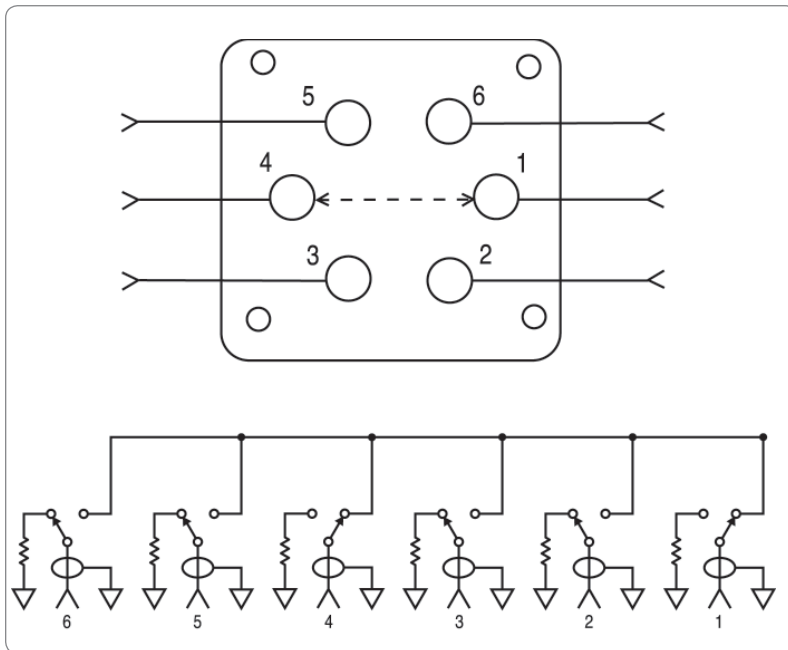

Figure 1. Agilent 87606B connection diagram and simplified schematic (RF path 4 to 1 shown)

Applications

Matrix signal routing

Figures 2 and 3 show the 87606B configured for blocking 2 x 4 and 3 x 3 applications. With outstanding repeatability and life greater than 5 million cycles, these switches enhance measurement confidence and reduce cost of ownership. In addition, the matrix switch has the versatility to provide single pole multiple throw signal routing up to 1 x 5 (SP5T). For applications requiring only single pole multithrow signal routing, the 87204 and 87206 series high performance switches are recommended.

Information on switch drivers can be found on page 8 of this document. For additional information, request one of the configuration guides listed in the *Related Literature* section on page 11 of this document.

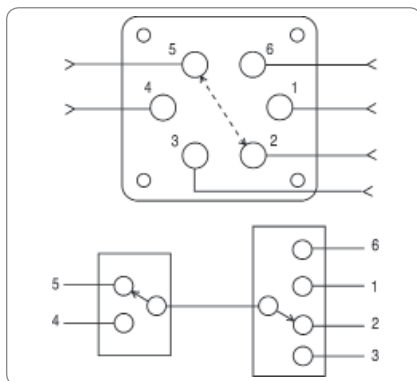

Figure 2. Matrix switch configured for a 2 x 4 blocking application (RF Path 5 to 2 shown)

General operation

The 87606B matrix switch consists of 6 ports which can be individually connected via internal microwave switches to form an RF path. When control inputs are sent to the switch, the internal logic and position sensing circuitry routes current to the appropriate solenoids to open or close the microwave switches based on the input state. The position sensing circuitry utilizes opto-electronic components to determine the position of the individual internal microwave switches. Each internal microwave switch has two solenoids: one to select the RF port, and one to unselect the RF port. The position sensing circuits serve two purposes: to enable solenoids that need to be switched, and to interrupt the solenoid current once the individual internal microwave switch is closed or opened. Each solenoid requires

200 mA @ 24 VDC nominal for 15 ms. The solenoid current is interrupted once the switching solenoids are magnetically latched. The supply current then returns to the standby level that is required by the opto-electronic components.

To configure a desired RF path, two ports must be closed. The ports are closed by grounding the “RF port close” pin that corresponds to the RF port (see Table 1). RF ports that are already closed must be opened if they are not part of the desired RF path. RF ports may be opened by grounding the “RF port open” pin that corresponds to the desired port (see Table 2).

Simultaneously selecting the “RF port close” pin and the “RF port open” pin for the same port will cause rapid cycling and premature failure of the switch.

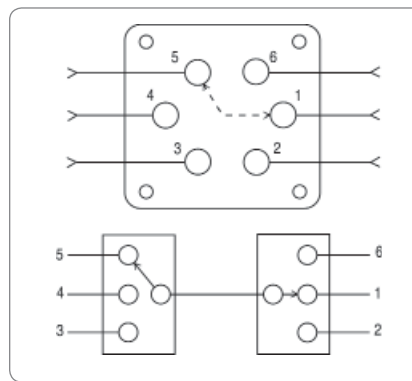

Figure 3. Matrix switch configured for a 3 x 3 blocking application (RF Path 5 to 1 shown)

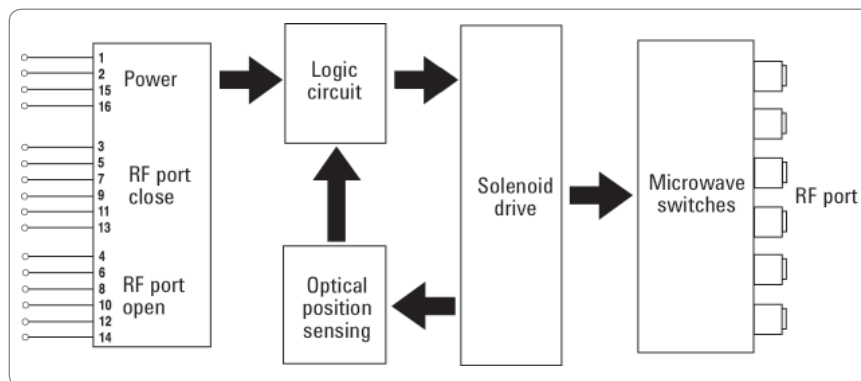

Figure 4. Agilent 87606B block diagram

General operation (Continued)

All of the “RF port open” solenoids are connected to pin 16 via logic circuitry. Grounding of pin 16 will open all RF ports (this feature is not available with Option 100, solder terminals).

Simultaneously grounding any “RF port close” pin and pin 16 will cause rapid cycling and premature failure of the switch.

Driving the switch

DC power connection

- Connect pin 1 to supply (+20 VDC to +32 VDC)
- Connect pin 15 to chassis ground to enable the electronic position-indicating circuitry and drive logic circuitry.

Warning: Damage to switch will occur if pin 15 is not grounded.

RF Path Selection

Close an RF Port

To connect any two RF ports, apply control signals to the corresponding drive pins as shown below.

Table 1. Agilent 87606B “Close” RF Port Control Data
(See Figure 7 for drive connection diagrams.)

RF Port	6	5	4	3	2
1	3, 13	3, 11	3, 9	3, 7	3, 5
2	5, 13	5, 11	5, 9	5, 7	
3	7, 13	7, 11	7, 9		
4	9, 13	9, 11			
5	11, 13				

Using Table 1, **select** (close) the desired RF path by connecting ground to the corresponding “drive” pins.

Open an RF Port

To open RF ports, apply control signal to the corresponding drive pins as shown below.

Table 2. Agilent 87606B “Open” RF Port Control Data
(See Figure 7 for drive connection diagrams.)

RF port	1	2	3	4	5	6
Drive pin	3	5	7	9	11	13

Using Table 2, **unselect** (open) the desired RF path by connecting ground to the corresponding “drive” pins.

Example: Configure the RF path from port 2 to port 5

Using the data in Tables 1 and 2, close ports 2 and 5 while opening all other ports (1, 3, 4, 6); ground pins 4, 5, 8, 10, 11, 14; all other drive pins must be removed from ground. Another method is to first apply ground to pin 16; with all other drive pins (3–14) ungrounded, for 15 milliseconds to open all paths, then apply ground to pins 5 and 11, to close ports 2 and 5.

RF port	1	2	3	4	5	6						
Drive pin	3	4	5	6	7	8	9	10	11	12	13	14
Standard, Option 100	U	G	G	U	U	G	U	G	G	U	U	G

U = Ungrounded, G = Grounded

Removing all drive pins (3–14) from ground and grounding pin 16 will open all RF paths. **Simultaneously grounding any “RF port close” pin and pin 16 will cause rapid cycling and premature failure of the switch.**

Break-before-make

Open the undesired RF path. After 15 ms (minimum), close the new RF port(s).

Make-before-break

Close the new RF port(s). After 15 ms (minimum), open the undesired RF port(s).

Specifications

Specifications describe the instrument's warranted performance.

Supplemental and **typical characteristics** are intended to provide information useful in applying the instrument by giving typical, but not warranted, performance parameters.

Maximum power rating: 1 W average into 50 ohm internal loads
 Switching: 1 W average
 Non-switching: 50 W Peak (10 μ s max, not to exceed 1 watt average)

Life: 5,000,000 cycles minimum

Switching speed: 15 ms maximum

Switch drive specifications

Parameter	Conditions	Min	Nom	Max	Units
Supply voltage, Vcc		20	24	32	V
Switching current	Vcc=24 VDC		200 ¹		mA
Standby current (quiescent)		25		50	mA

1. 200 mA is required for each RF port closed or open. Using “open all ports” (pin 16) will require up to 1200 mA (6 ports times 200 mA each). See General Operation, page 3.

Specifications *(Continued)*

Frequency range	DC to 20 GHz
Insertion loss	0.34 dB + 0.033 x frequency (GHz) maximum
Isolation	100 dB minimum to 12 GHz 80 dB minimum from 12 to 15 GHz 70 dB minimum from 15 to 20 GHz
SWR	1.21 maximum from DC to 4 GHz 1.35 maximum from 4 to 10 GHz 1.5 maximum from 10 to 15 GHz 1.7 maximum from 15 to 18 GHz 1.9 maximum from 18 to 20 GHz

Supplemental characteristics¹

Insertion loss repeatability (measured at 25 °C)	0.03 dB
Characteristic impedance	50 ohms
RF connectors	SMA (f)

1. **Supplemental** and **typical characteristics** are intended to provide information useful in applying the instrument by giving typical, but not warranted, performance parameters.

Supplemental Characteristic

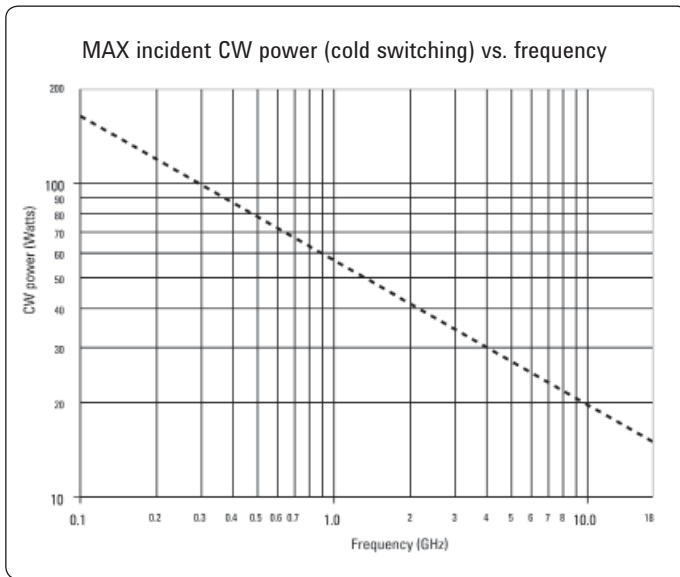

Reference conditions:

- Cold switching only (NO Hot switching)
- Ambient temperature of 75 °C or less
- Sea level (0.88 derating @ 15,000 ft.)
- Load VSWR < 1.2 (see graph for derating above 1.2 VSWR)
- Power Handling at 25 °C is 100 W at 4 GHz

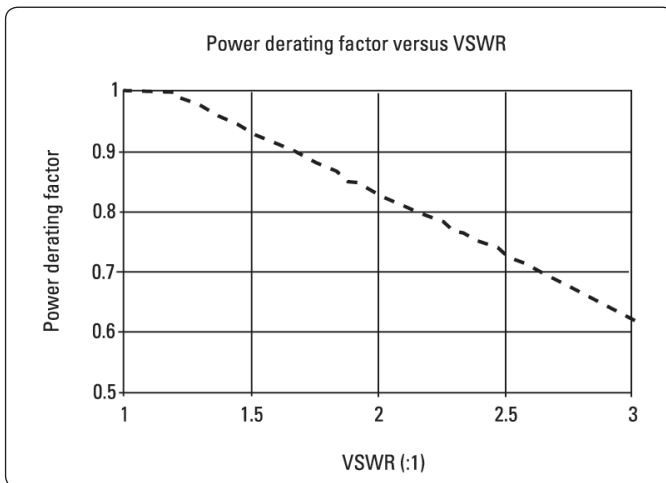

Environmental Specifications

Operating temperature:	-25 to 75 °C
Storage temperature:	-55 to 85 °C
Temperature cycling:	-55 to 85 °C, 10 cycles per MIL-STD-202F, Method 107D, Condition A (modified)
Vibration	
Operating:	7 g: 5 to 2000 Hz at 0.25 in p-p
Survival:	20 g: 20 to 2000 Hz at 0.06 in p-p, 4 min/cycle, 4 cycles/axis
Random:	2.41 g (rms) 10 min/axis
Shock	
Half-sine:	500 g at 0.5 ms, 3 drops/direction, 8 total
Operating:	50 g at 6 ms, 6 directions
Moisture resistance:	65 °C, 95% RH, 10 days per MIL-STD-202F, Method 106E
Altitude storage:	50,000 feet (15,240 meters) per MIL-STD-202F, Method 105C, Condition B
RFI:	Per MIL-STD-461C, RE02, Part 4
Magnetic field:	< 5 gauss ¼ inch from surface

Physical Specifications

Dimensions:	Per Figure 6
Weight:	229 gm (0.50 lb)

Dimensions
in millimeters
and (inches)

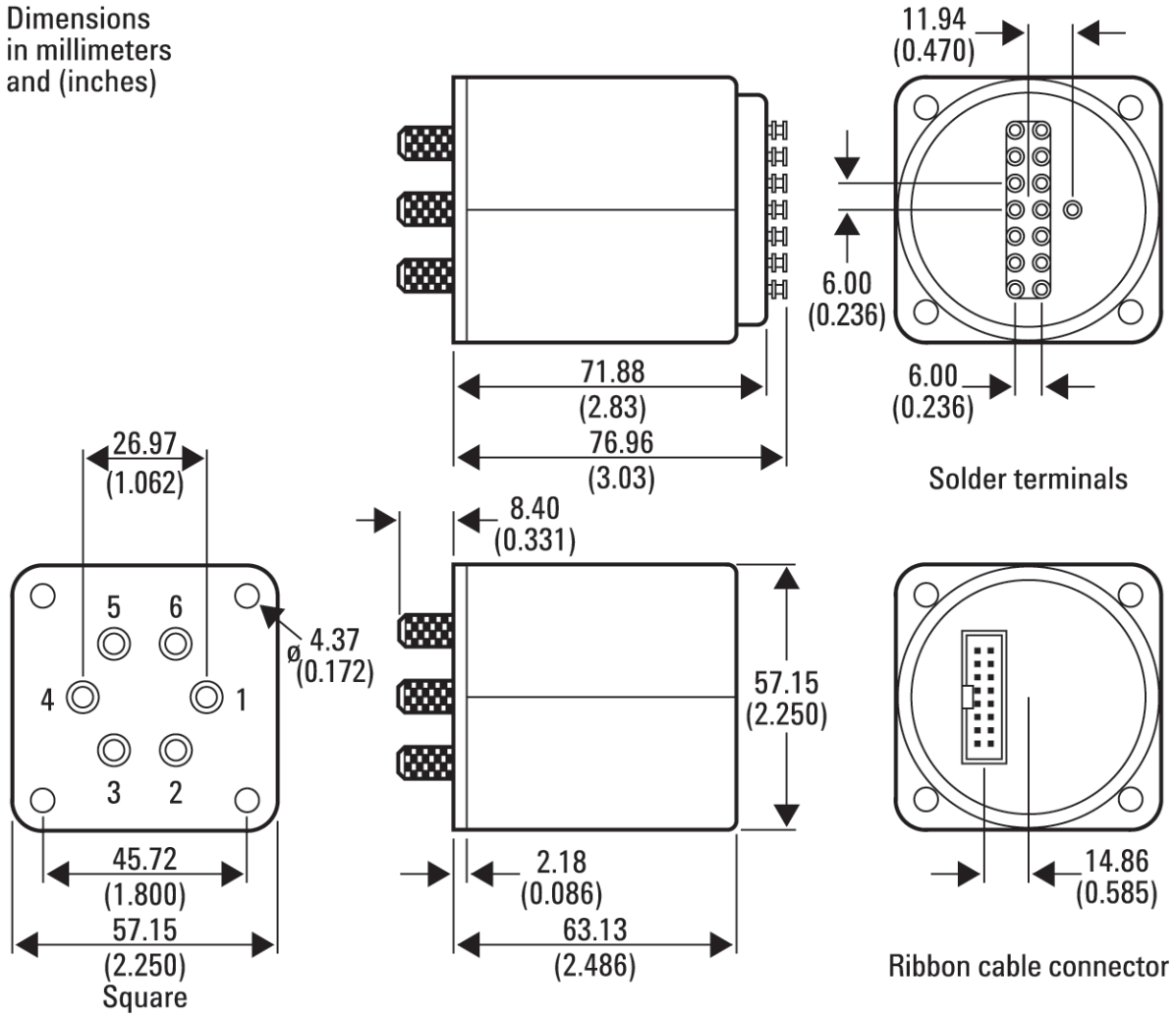

Figure 6. Product outline

Troubleshooting

Symptom	Probable cause
1. Will not switch	<ul style="list-style-type: none"> • Not connected to supply • Supply < 20 V • Insufficient supply current • Pin 15 not connected to ground • Select line not at ground
2. Switch buzzes	<ul style="list-style-type: none"> • "Open" and "close" pins on same RF port selected simultaneously • Pin 16 and any "close" pins selected simultaneously

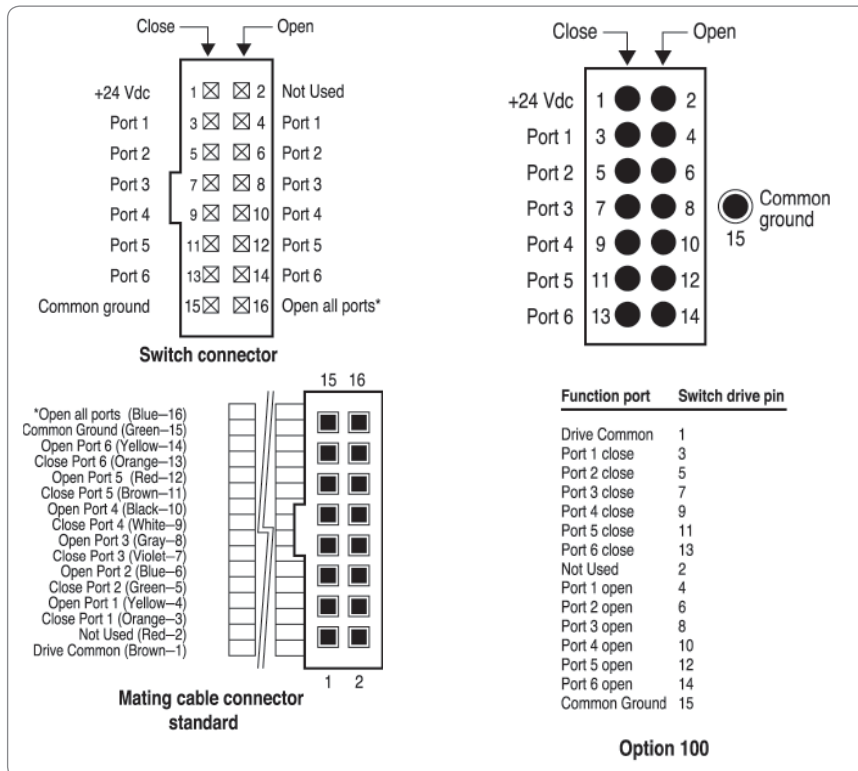

Figure 7. Drive connection diagrams

* Open all ports pin is not available with Option 100.

Ordering Information

Switch

- 87606B** Coaxial matrix switch, dc to 20 GHz
- Option 100** Solder terminals to replace ribbon cable
- Option UK6** Commercial calibration test data with certificate
- Option UKS** Commercial calibration certificate

Drivers

11713B/C Attenuator switch driver

Drives up to 10 or 20 sections of switches or attenuators.

[5061-0969 Accessory cable](#)

Viking connector to bare tinned wires (60 inches long). Use two (2) to connect the 11713B/C to one 87606B, Option 100 switch.

Related Literature

Agilent 11713B/C Attenuator/Switch Drivers, Configuration Guide, 5989-7277EN

Agilent RF and Microwave Switch, Selection Guide, 5989-6031EN

Power Handling Capability of Electromechanical Switches, 5989-6032EN

How Operating Life and Repeatability of Agilent's Electromechanical Switches Minimize System Uncertainty, 5989-6085EN



Agilent Email Updates

www.agilent.com/find/emailupdates
Get the latest information on the products and applications you select.



Agilent Direct

www.agilent.com/find/agilentdirect
Quickly choose and use your test equipment solutions with confidence.



www.lxistandard.org

LXI is the LAN-based successor to GPIB, providing faster, more efficient connectivity. Agilent is a founding member of the LXI consortium.

Remove all doubt

Our repair and calibration services will get your equipment back to you, performing like new, when promised. You will get full value out of your Agilent equipment throughout its lifetime. Your equipment will be serviced by Agilent-trained technicians using the latest factory calibration procedures, automated repair diagnostics and genuine parts. You will always have the utmost confidence in your measurements. For information regarding self maintenance of this product, please contact your Agilent office.

Agilent offers a wide range of additional expert test and measurement services for your equipment, including initial start-up assistance, onsite education and training, as well as design, system integration, and project management.

For more information on repair and calibration services, go to:

www.agilent.com/find/removealldoubt

Product specifications and descriptions in this document subject to change without notice.

www.agilent.com

www.agilent.com/find/mta

For more information on Agilent Technologies' products, applications or services, please contact your local Agilent office. The complete list is available at:

www.agilent.com/find/contactus

Americas

Canada	(877) 894-4414
Latin America	305 269 7500
United States	(800) 829-4444

Asia Pacific

Australia	1 800 629 485
China	800 810 0189
Hong Kong	800 938 693
India	1 800 112 929
Japan	0120 (421) 345
Korea	080 769 0800
Malaysia	1 800 888 848
Singapore	1 800 375 8100
Taiwan	0800 047 866
Thailand	1 800 226 008

Europe & Middle East

Austria	01 36027 71571
Belgium	32 (0) 2 404 93 40
Denmark	45 70 13 15 15
Finland	358 (0) 10 855 2100
France	0825 010 700*
	*0.125 €/minute
Germany	07031 464 6333
Ireland	1890 924 204
Israel	972-3-9288-504/544
Italy	39 02 92 60 8484
Netherlands	31 (0) 20 547 2111
Spain	34 (91) 631 3300
Sweden	0200-88 22 55
Switzerland	0800 80 53 53
United Kingdom	44 (0) 118 9276201

Other European Countries:

www.agilent.com/find/contactus

Revised: March 24, 2009

© Agilent Technologies, Inc. 2007, 2009
Printed in USA, June 30, 2009
5965-7842E



Agilent Technologies