

Agilent AN 1287-9

In-Fixture Measurements Using Vector Network Analyzers

Application Note

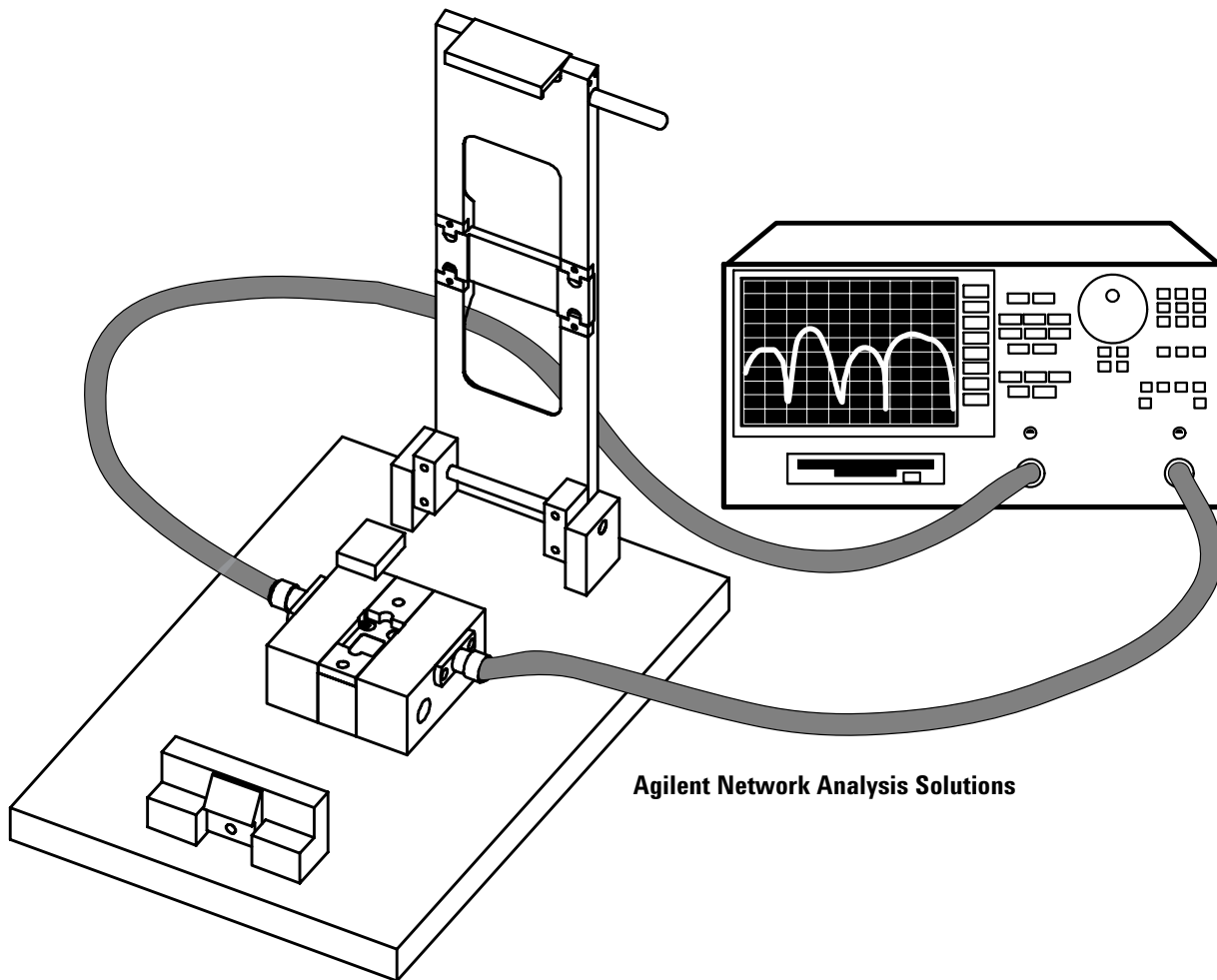
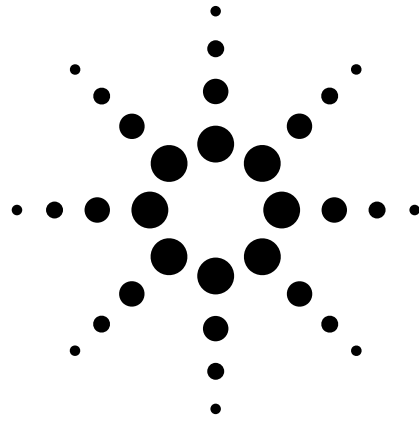

Agilent Network Analysis Solutions



Agilent Technologies

Table of Contents

3	Introduction
3	The need for fixtures
4	Measurement errors
4	Measurement calibration
5	Calibration kit
5	Standard definition
6	Standard class assignment
7	Fixtures for R&D versus manufacturing
8	Removing fixture errors
12	Characterizing calibration standards for SOLT calibration
13	Characterizing a short
13	Characterizing an open
13	How to determine open capacitance
15	Characterizing a load
16	Characterizing a thru
17	TRL/LRM calibration
17	TRL terminology
17	How TRL*/LRM* calibration works
17	TRL* error model
18	Isolation
18	Source match and load match
19	How true TRL/LRM works (four-sampler receiver architecture only)
19	Improving raw source match and load match for TRL*/LRM* calibration
20	The TRL calibration
20	Requirements for TRL standards
22	Fabricating and defining calibration standards for TRL/LRM
25	Using TDR to evaluate fixtures and standards
30	Biasing active parts
32	Conclusion

Introduction

This application note describes the use of vector network analyzers when making measurements of components in fixtures. We will explain the need for fixtures, the selection of fixtures, measurement error, how to minimize the errors, basic fixture construction, and the construction and characterization of required calibration standards, if commercial fixtures are not available for your device.

The need for fixtures

Size, weight, and cost constraints along with higher operating frequencies and advances in technology are driving the use of smaller and more integrated packaged parts at the assembly level. Now there are many nonstandard surface-mount technology (SMT) packages for many RF (<3 GHz) applications. The physical dimensions of these parts vary greatly, due to differing technologies, power-handling requirements, environmental conditions, and design criteria. With the wide variety of component sizes and shapes, no single fixture fits all.

Making quality RF measurements on devices with standard coaxial connectors is relatively easy. Very accurate measurements can be made using commercial calibration kits and standard error-correction routines found in most network analyzers. Devices without connectors are difficult to measure since some sort of test fixture is required to provide electrical and mechanical connection between the device under test (DUT) and the coaxial-

connector-based test equipment. In addition, in-fixture calibration standards are often required to achieve the level of measurement accuracy demanded by many of today's devices.

An "ideal" fixture would provide a transparent connection between the test instrument and the device being tested. It would allow direct measurement of the DUT, without imposition of the fixture's characteristics. In parametric terms, this would mean the fixture would have no loss, a flat frequency response with linear phase, no mismatches, be a precisely known electrical length, and have infinite isolation between input and output (zero crosstalk). If we could make such a fixture, calibration would be unnecessary.

Since it is impossible to make an ideal fixture, we can only approximate the ideal case. We need to do this by optimizing the performance of the test fixture relative to the performance of the DUT. We can try to make the loss of the fixture smaller than the specified gain or insertion loss uncertainty of the DUT. The bandwidth of the fixture needs to be wider than the desired measurement bandwidth of the DUT. Mismatch can be minimized with good design and the use of effective measurement tools such as time-domain reflectometry (TDR) to identify the mismatches in the fixture. The electrical length of the fixture can be measured. Fixture crosstalk need only be less than the isolation of the device under test. Since we can only approximate the perfect fixture, the type of calibration required for any particular application will depend solely on how stringent the DUT specifications are.

Measurement errors

Before we discuss calibration, we need to briefly discuss what factors contribute to measurement uncertainty.

Errors in network analyzer measurements can be separated into three categories:

Drift errors occur when the test system's performance changes after a calibration has been performed. They are primarily caused by temperature variation and can be removed by recalibration.

Random errors vary as a function of time. Since they are not predictable they cannot be removed by calibration. The main contributors to random errors are instrument noise, switch repeatability, and connector repeatability. The best way to reduce random errors is by decreasing the IF bandwidth, or by using trace averaging over multiple sweeps.

Systematic errors include mismatch, leakage, and system frequency response. In most microwave or RF measurements, systematic errors are the most significant source of measurement uncertainty.

The six systematic errors in the forward direction are directivity, source match, reflection tracking, load match, transmission tracking, and isolation. The reverse error model is a mirror image, giving a total of 12 errors for two-port measurements. Calibration is the process for removing these errors from network analyzer measurements.

Measurement calibration

A more complete definition of measurement calibration using the network analyzer and a description of error models are included in the network analyzer operating manual. The basic ideas are summarized here.

Measurement calibration is a process in which a network analyzer measures precisely known devices and stores the vector differences between the measured and the actual values. The error data is used to remove the systematic errors from subsequent measurements of unknown devices.

There are six types of calibrations available with the vector network analyzer: response, response and isolation, S11 1-PORT, S22 1-PORT, FULL 2-port, and TRL 2-PORT. Each of these calibration types solves for a different set of systematic measurement errors.

A RESPONSE calibration solves for the systematic error term for reflection or transmission tracking, depending on the S-parameter that is activated on the network analyzer at the time of the calibration. RESPONSE & ISOLATION adds correction for crosstalk to a simple RESPONSE calibration. An S11 1-PORT calibration solves for forward error terms, directivity, source match, and reflection tracking. Likewise, the S22 1-PORT calibration solves for the same terms in the reverse. Full 2-PORT and TRL 2-PORT calibrations include forward and reverse error terms of both ports, plus transmission tracking and isolation.

The type of measurement calibration selected by the user depends on the device to be measured (for example one-port or two-port device) and the extent of accuracy enhancement desired. Further, a combination of calibrations can be used in the measurement of a particular device.

The accuracy of subsequent DUT measurements is dependent on the accuracy of the test equipment, how well the known devices are modeled, and the exactness of the error correction model.

Calibration kit

Measurement accuracy is largely dependent upon calibration standards, and a set of calibration standards is often supplied as a calibration kit. Each standard has precisely known or predictable magnitude and phase response as a function of frequency. For the network analyzer to use the

standards of a calibration kit, the response of each standard must be mathematically defined and then organized into a standard class that corresponds to the error model used by the network analyzer. Agilent Technologies currently supplies calibration kits for most coaxial components. However, when measuring non-coaxial components it is necessary to create and define the standards that will be used with the fixture.

Standard definition

The standard definition describes the electrical characteristics (delay, attenuation, and impedance) of each calibration standard. These electrical characteristics can be derived mathematically from the physical dimensions and material of each calibration standard or from the actual measure response. A Standard Definitions table (see Figure 1) lists the parameters that are used by the network analyzer to specify the mathematical model.

Standard Definitions

System $Z_0^a =$ _____ Calibration Kit Label: _____

Disk File Name: _____

STANDARD ^b	NO.	TYPE	C0 ^e ×10 ⁻¹⁵ F	C1 ^e ×10 ⁻²⁷ F/Hz	C2 ^e ×10 ⁻³⁶ F/Hz ²	C3 ^e ×10 ⁻⁴⁵ F/Hz ³	FIXED ^c SLIDING or OFFSET	TERM ^d IMPED Ω	OFFSET			FREQ (GHz)		COAX or WG	STND LABEL	
									DELAY s	Z ₀ Ω	LOSS dB/s	MIN	MAX			
1																
2																
3																
4																
5																
6																
7																
8																

^aEnsure system Z_0 of network analyzer is set to this value.
^bOpen, short, load, delay/thru, or arbitrary impedance.
^cLoad or arbitrary impedance only.
^dArbitrary impedance only, device terminating impedance.
^eOpen standard types only.

Figure 1.

Standard class assignment

The standard class assignment organizes calibration standards into a format that is compatible with the error models used in measurement calibration. A class or group of classes corresponds to one of seven calibration types used in the network analyzer. A Standard Class Assignments table (see Figure 2)

lists the class assignments for each standard type. Agilent Application Note 1287-3, *Applying Error Correction to Network Analyzer Measurements*, will provide a more in-depth discussion of network analyzer basics.

Standard Class Assignments

Calibration Kit Label: _____
Disk File Name: _____

Class	Standard Reference Numbers								Standard Class Label
	1	2	3	4	5	6	7	8	
S ₁₁ A									
S ₁₁ B									
S ₁₁ C									
S ₂₂ A									
S ₂₂ B									
S ₂₂ C									
Forward Transmission									
Reverse Transmission									
Forward Match									
Reverse Match									
Response									
Response and Isolation									
TRL thru									
TRL reflect									
TRL line or match									

Figure 2.

Fixtures for R&D versus manufacturing

Fixtures intended for manufacturing applications look different than those used in R&D, since the basic design goals are different. In manufacturing, high throughput is the overriding concern. A fixture that allows quick insertion, alignment and clamping is needed. It must be rugged, since many thousands

of parts will be inserted in the fixture over its lifetime. Fixtures designed for manufacturing use tend to be mechanically sophisticated. For R&D applications the fixtures can be much simpler and less rugged. They can be PCB-based, and since we are usually testing only a few devices, we can get by with soldering parts in and out of the fixture.

Fixturing in R&D versus Manufacturing

Manufacturing

- quick insertion, alignment, clamping
- rugged for high-volume use
- compliant contacts
- usually mechanically sophisticated

R&D

- solder parts onto fixture
- ruggedness not an issue for low volumes
- soldering handles leaded / leadless parts
- often simple (e.g., PCB with connectors)

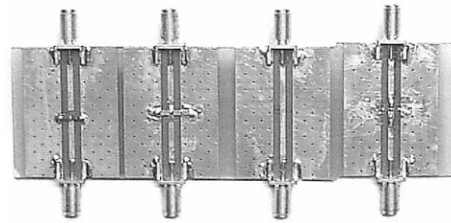
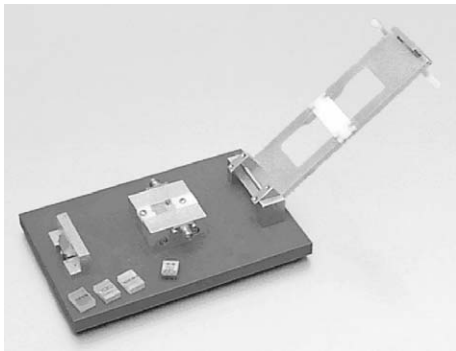

Figure 3.

Typical PCB Fixture (with Cal Standards)

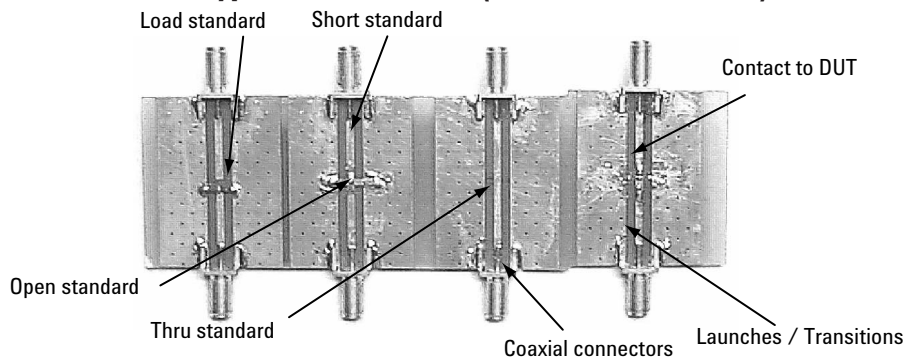

Figure 4.

This is an example of a typical fixture used in the R&D application. It incorporates calibration

standards and has a section where the DUT can be attached.

Removing fixture errors

There are three fundamental techniques for removing errors introduced by a fixture: modeling, de-embedding, and direct measurement. Each has relatively simple and more complicated versions that require greater work but yield more accurate measurements. The relative performance of the fixture compared to the specifications of the DUT being measured will determine what level of calibration is required to meet the necessary measurement accuracy.

Calibration based on modeling uses mathematical corrections derived from an accurate model of the fixture. Often, the fixture is measured as part of the process of providing an accurate model.

Modeling requires that we have data regarding the fixture characteristics. The simplest way to use this data is with the port extension feature of the network analyzer. First you perform a full two-port calibration at the points indicated in Figure 5. This calibration establishes the reference plane at the junction of the test port cables. The fixture is then connected to the test port cables and the reference plane is then mathematically adjusted to the DUT, using the port extension feature of the network analyzer. If the fixture performance is considerably better than the specifications of the DUT, this technique may be sufficient.

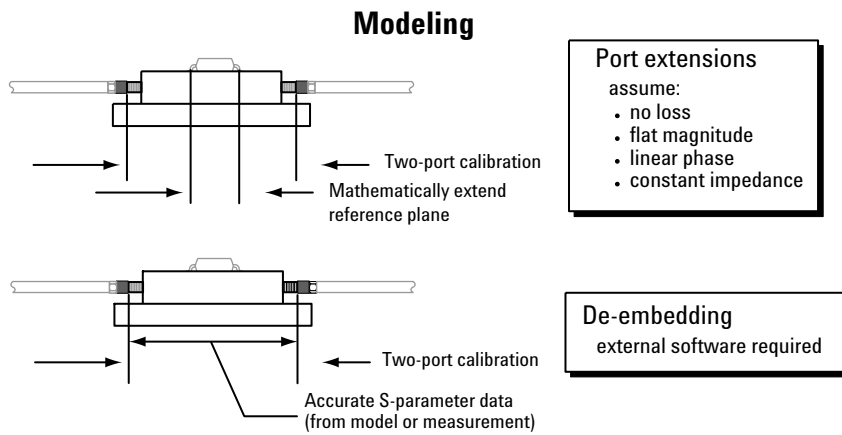

Figure 5.

De-embedding requires an accurate linear model of the fixture, or measured S-parameter data of the fixture. External software is needed to combine the error data from a calibration done without the fixture (using coaxial standards) with the modeled fixture error. If the error terms of the fixture are generated solely from a model, the overall measurement accuracy depends on how well the actual performance of the fixture matches the modeled performance. *For fixtures that are not based on simple transmission lines, determining a precise model is usually harder than using the direct measurement method.*

Direct measurement usually involves measuring physical calibration standards and calculating error terms. This method is based on how precisely we know the characteristics of our calibration standards. The number of error terms that can be corrected varies considerably depending on the type of calibration used. Normalization only removes one error term, while full two-port error correction accounts for all 12 error terms.

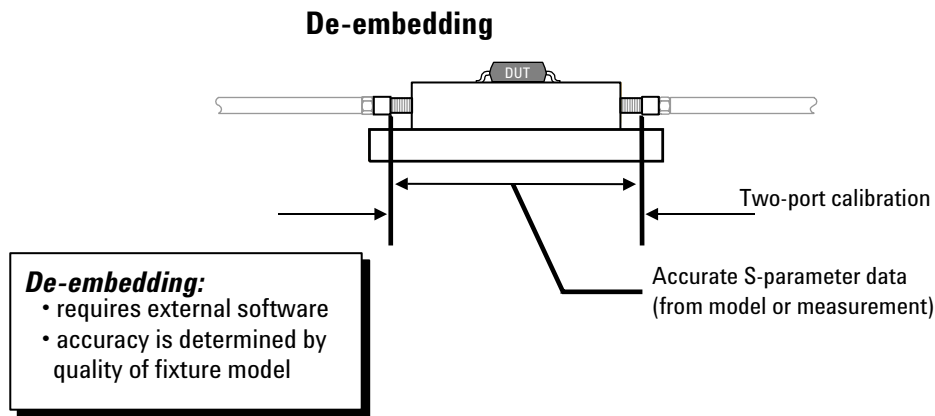

Figure 6.

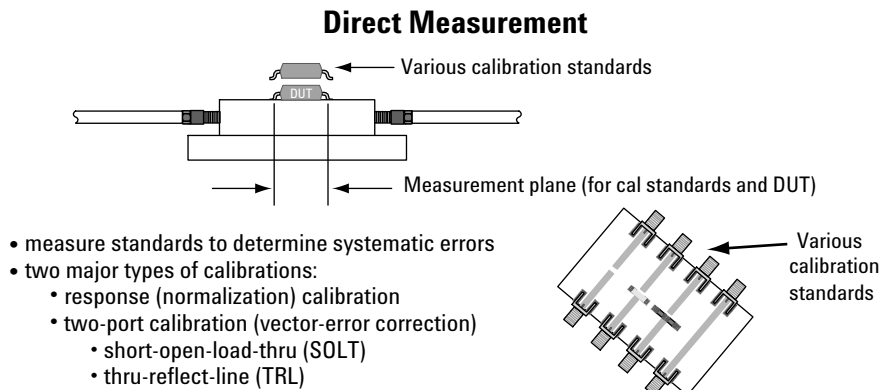

Figure 7.

Direct measurements have the advantage that the precise characteristics of the fixture do not need to be known beforehand. They are measured during the calibration process. The simplest form of direct measurement is a response calibration, which is a form of normalization. A reference trace is placed in memory and subsequent traces are displayed as data divided by memory. A response calibration only requires one standard each for transmission (a thru) and reflection (a short or open).

However, response calibration has a serious inherent weakness due to the lack of correction for source and load mismatch and coupler/bridge directivity. Mismatch is especially troublesome for low-loss transmission measurements (such as measuring a filter passband or a cable), and for

reflection measurements. Using response calibration for transmission measurements on low-loss devices can result in considerable measurement uncertainty in the form of ripple. Measurement accuracy will depend on the relative mismatch of the test fixture in the network analyzer compared to the DUT.

When measuring transmission characteristics with fixtures, considerable measurement accuracy improvement can be obtained by performing a two-port correction at the ends of test cables. This calibration improves the effective source and load match of the network analyzer, thus helping to reduce the measurement ripple, the result of reflections from the fixture and analyzer's test ports.

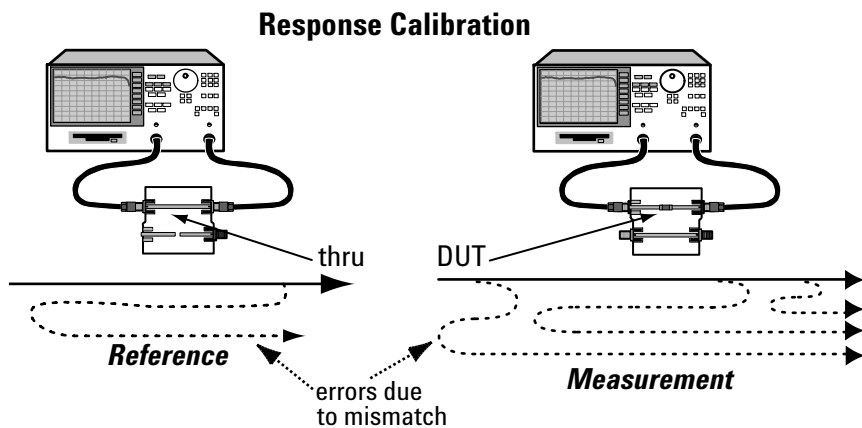

Figure 8.

Two-port calibration provides much more accurate measurements compared to a response calibration. It also requires more calibration standards. There are two basic types of two-port calibration: Short-Open-Load-Thru (SOLT) and the Thru-Reflect-Line (TRL). These are named after the types of standards used in the calibration process.

A calibration at the coaxial ports of the network analyzer removes the effects of the network analyzer and any cables or adapters before the fixture; however, the effects of the fixture itself are not accounted for. An in-fixture calibration is preferable, but high-quality SOLT standards are not readily available to allow a conventional full two-port calibration of the system at the desired measurement plane of the device. In microstrip, a short circuit is inductive, an open circuit radiates energy, and a high-quality purely resistive load is difficult to produce over a broad frequency range. The TRL

two-port calibration is an alternative to the traditional SOLT Full two-port calibration technique that utilizes simpler, more convenient standards for device measurements in the microstrip environment.

In all measurement environments, the user must provide calibration standards for the desired calibration to be performed. The advantage of TRL is that only three standards need to be characterized as opposed to four in the traditional SOLT full two-port calibrations. Further, the requirements for characterizing the T, R, and L standards are less stringent and these standards are more easily fabricated.

For more information on network analyzer calibrations, please see Agilent Application Note 1287-3, *Applying Error Correction to Network Analyzer Measurements*.

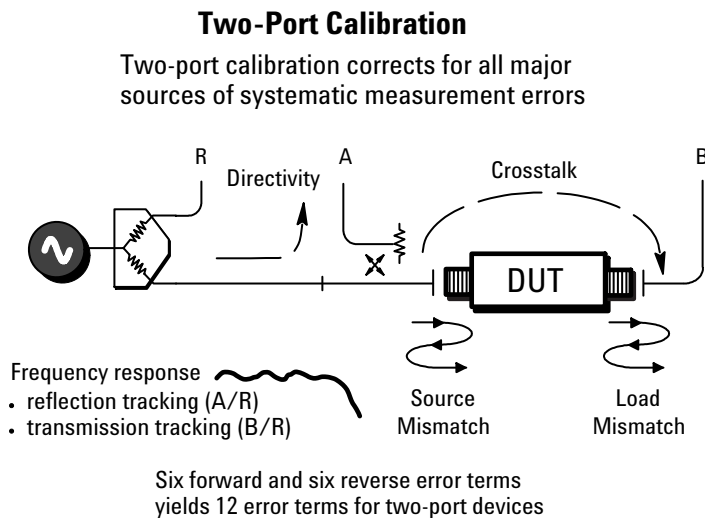

Figure 9.

Characterizing calibration standards for SOLT calibration

Most network analyzers already contain standard calibration kit definition files that describe the characteristics of a variety of calibration standards. These calibration kit definitions usually cover the major types of coaxial connectors used for component and circuit measurements, for example Type-N, 7 mm, 3.5 mm and 2.4 mm. Most high-performance network analyzers allow the user to modify the definitions of the calibration standards. This capability is especially important for fixture-based measurements, because the in-fixture calibration standards rarely have the same attributes as the coaxial standards. Custom calibration standards, such as those used with fixtures, require

the user to characterize the standards and enter the definitions into the network analyzer. The calibration kit definition must match the actual standards for accurate measurements. Definitions of the in-fixture calibration standards can be stored in the analyzer as a custom user-defined calibration kit.

While there are many characteristics used to describe calibration standards, only a few need to be modified for most fixture applications. For a properly designed PCB fixture, only the fringing capacitance of the open standard and the delay of the short need to be characterized.

Short-Open-Load-Thru (SOLT) Calibration

SOLT calibration is attractive for RF fixtures

- simpler and less-expensive fixtures and standards
- relatively easy to make broadband calibration standards
 - short, thru are easiest
 - open requires characterization
 - load is hardest (quality determines corrected directivity)

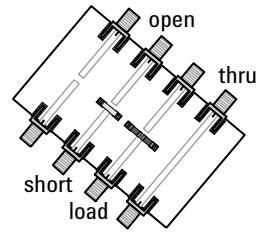

Figure 10.

Characterizing a short

The electrical definition of an ideal short is unity reflection with 180 degrees of phase shift. All of the incident energy is reflected back to the source, perfectly out of phase with the reference. A simple short circuit from a single conductor to ground makes a good short standard. For example, the short can be a few vias (plated through holes) to ground at the end of a micro-strip transmission line. If coplanar transmission lines are used, the short should go to both ground planes.

To reduce the inductance of the short, avoid excessive length. A good RF ground should be near the signal trace. If the short is not exactly at the contact plane of the DUT, an offset length can be entered (in terms of electrical delay) as part of the user-defined calibration kit.

Characterizing an open

The open standard is typically realized as an unterminated transmission line. Electrical definition of

an ideal open has “unity reflection with no phase-shift.” The actual model for the open, however, does have some phase shift due to fringing capacitance.

How to determine open capacitance

Determining the fringing capacitance is only necessary above approximately 300 MHz. The fringing capacitance can be measured as follows:

1. Perform a one-port calibration at the end of the test cable. Use a connector type that is compatible with the fixture. For example, use APC 3.5-mm standards for a fixture using SMA connectors.
2. Connect the fixture and measure the load standard. This data should be stored in memory and the display changed to “data minus memory.” This step subtracts out the reflection of the fixture connector (assuming good consistency between connectors), so that we can characterize just the open. (An alternative is to use time-domain gating to remove the effect of the connector.)

Determining Open Capacitance

- perform one-port calibration at end of test cable
- measure load, store data in memory, display data-mem
- measure short, add port extension until flat 180° phase
- measure open, read capacitance from admittance Smith chart
- enter capacitance coefficient(s) in cal-kit definition of open

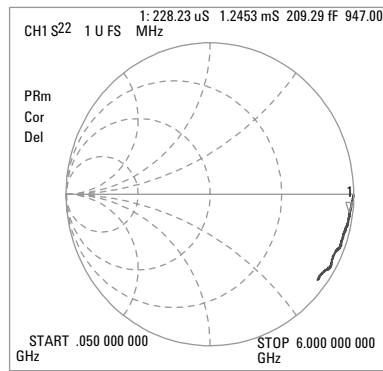

watch out for "negative" capacitance (due to long or inductive short)
adjust with negative offset-delay in open <or>
positive offset-delay in short

Figure 11.

3. Measure the short standard. Set the port extension to get a flat 180 degrees phase response. To fine-tune the value of port extension, set the phase-off set value for the trace to 180 degrees and expand degrees-per-division scale. Mismatch and directivity reflections may cause a slight ripple, so use your best judgment for determining the flattest trace, or use marker statistics (set the mean value to zero).
4. Set the network analyzer display format to Smith chart, the marker function to Smith chart format $G+jB$ (admittance) and then measure the open standard. Markers now read $G+jB$ instead of the $R+jX$ of an impedance Smith chart. Admittance must be used because the fringing capacitance is modeled as a shunt element, not a series element. The fringing capacitance (typically 0.03 to 0.25 pF) can be directly read at the frequency of interest using a trace marker. At RF, a single capacitance value (C_0) is generally adequate for the calibration kit definition of the open. In some cases, a single capacitance number may not be adequate, as capacitance can vary with frequency. This is typically true for the measurements that extend well into the microwave frequency range. **Because capacitance varies with frequency, at frequencies above 3 GHz it may be better to use a TRL/LRM calibration.**

When measuring the fringing capacitance, a problem can arise if the short standard is electrically longer than the open standard. The measured impedance of the open circuit then appears to be a negative capacitor, indicated by a trace that rotates backwards (counter-clockwise) on the Smith chart. This problem is a result of using an electrically longer short standard as the 180 degrees phase reference. The electrically shorter open will then appear to have positive phase. The remedy for this is to decrease the port extension until the phase is monotonically negative. The model for the open will then have a normal (positive) capacitance value. The value of the negative offset delay that needs to be included in the open standard definition is simply the amount by which port extension was reduced (for instance, the difference in the port extension values between the short and the open). In effect, we have now set the reference plane at the short. Alternatively, the offset delay of the open can be set to zero, and a small positive offset delay can be added to the model of the short standard. This will set an effective reference plane at the open.

Characterizing a load

An ideal load reflects none of the incident signal, thereby providing a perfect termination over a broad frequency range. We can only approximate an ideal load with a real termination because some reflection always occurs at some frequency, especially with non-coaxial actual standards.

At RF, we can build a good load using standard surface-mount resistors. Usually, it is better to use two 100-ohm resistors in parallel instead of a single 50-ohm resistor, because the parasitic inductance is cut in half. For example, 0805-size SMT resistors have about 1.2 nH series inductance and 0.2 pF parallel capacitance. Two parallel 100-ohm 0805 resistors have nearly a 20-dB better match than a single 50-ohm resistor.

Port Extensions

- port-extension feature of network analyzer removes linear portion of phase response
- accounts for added electrical length of fixture
- doesn't correct for loss or mismatch
- mismatch can occur from
 - launches
 - variations in transmission line impedance

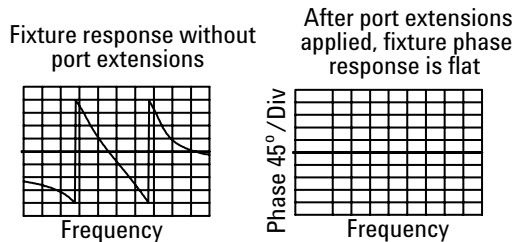

Figure 12.

Characterizing a thru

The thru standard is usually a simple transmission line between two coaxial connectors on the fixture. A good thru should have minimal mismatch at the connector launches and maintain a constant impedance over its length (which is generally the case for PCB thrus). The impedance of the thru should match the impedance of the transmission lines used with the other standards (all of which should be 50 ohms).

Notice in Figure 12, the PC board is wider for the transmission line where the DUT will be soldered.

Since we want the two halves of line to be equal in electrical length to the thru line, the PCB must be widened by the length of the DUT.

With a properly designed PC board fixture, the short (or open) defines a calibration plane to be in the center of the fixture. This means the thru will have a length of zero (which is usually not the case for fixtures used in manufacturing applications, where a set of calibration standards is inserted into a single fixture). Since the length is zero, we do not have to worry about characterizing the loss of the thru or its phase shift.

Load Standard

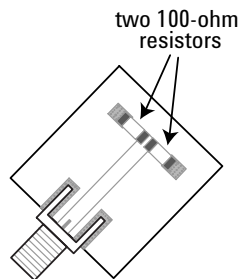
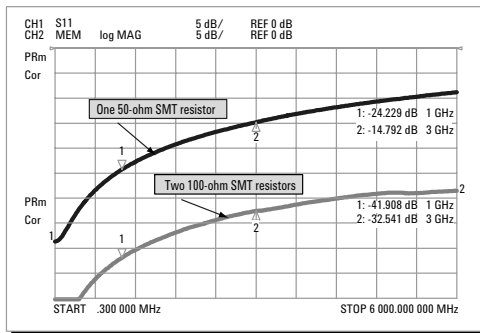

- ideal: zero reflection at **all** frequencies
- can only **approximate** at best (usually somewhat inductive)
- **two 100-ohm resistors in parallel** better than a single 50-ohm resistor

Figure 13.

Thru Standard

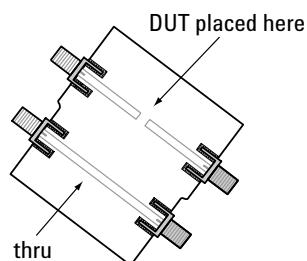

- thru is a simple **transmission line**
- desire **constant impedance** and **minimal mismatch** at ends
- PCB is widened by the length of the DUT to insure that both lines are of equal length

Figure 14.

TRL/LRM Calibration

TRL terminology

Notice that the letters TRL, LRL, LRM, and TRM are often interchanged, depending on the standards used. For example, “LRL” indicates that two lines and a reflect standard are used; “TRM” indicates that a thru, reflection, and match standards are used. All of these refer to the same basic method.

How TRL*/LRM* calibration works

The TRL*/LRM* calibration is used in a network analyzer with a three-sampler receiver architecture, and relies on the characteristic impedance of simple transmission lines rather than on a set of discrete impedance standards. Since transmission lines are relatively easy to fabricate (in a microstrip, for example), the impedance of these lines can be determined from the physical dimensions and substrate’s dielectric constant.

TRL* error model

For TRL* two-port calibration, a total of 10 measurements are made to quantify eight unknowns (not including the two isolation error terms). Assume the two transmission leakage terms, E_{XF} and E_{XR} , are measured using the conventional technique. Although this error model is slightly different from the traditional Full two-port 12-term model, the conventional error terms may be derived from it. For example, the forward reflection tracking (E_{RF}) is represented by the product of ϵ_{10} and ϵ_{01} . Also notice that the forward source match (E_{SF}) and reverse load match (E_{LR}) are both represented by ϵ_{11} , while the reverse source match (E_{SR}) and forward load match (E_{LF}) are both represented by ϵ_{22} . In order to solve for these eight unknown TRL* error terms, eight linearly independent equations are required.

8 Term TRL* Model

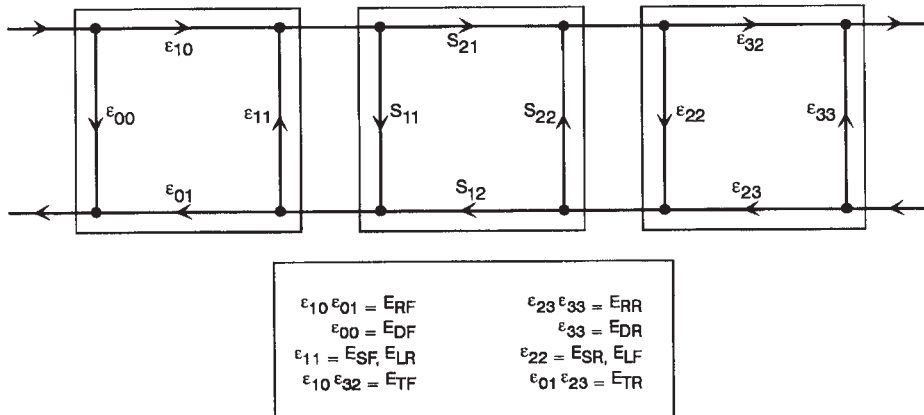

Figure 15. 8-term TRL* error model and generalized coefficients

The first step in the TRL* two-port calibration process is the same as the transmission step for a full two-port calibration. For the thru step, the test ports are connected together directly (zero length thru) or with a short length of transmission line (non-zero length thru) and the transmission frequency response and port match are measured in both directions by measuring all four S-parameters.

For the reflect step, identical high reflection coefficient standards (typically open or short circuits) are connected to each test port and measured (S11 and S22).

For the line step, a short length of transmission line (different in length from the thru) is inserted between port 1 and port 2 and again the frequency response and port match are measured in both directions by measuring all four S-parameters.

In total, 10 measurements are made, resulting in 10 independent equations. However, the TRL* error model has only eight error terms to solve for. The characteristic impedance of the line standard becomes the measurement reference and, therefore, has to be assumed ideal (or known and defined precisely).

At this point, the forward and reverse directivity (E_{DF} and E_{DR}), transmission tracking (E_{TF} and E_{TR}), and reflection tracking (E_{RF} and E_{RR}) terms may be derived from the TRL* error terms. This leaves the isolation (E_{XF} and E_{XR}), source match (E_{SF} and E_{SR}) and load match (E_{LF} and E_{LR}) terms to discuss.

Isolation

Two additional measurements are required to solve for the isolation terms (E_{XF} and E_{XR}). Isolation is characterized in the same manner as the full two-port calibration. Forward and reverse isolation are measured as the leakage (or crosstalk) from port 1 to port 2 with each port terminated. The isolation part of the calibration is generally only necessary when measuring high-loss devices (greater than 70 dB).

Note: If an isolation calibration is performed, the fixture leakage must be the same during the isolation calibration and the measurement.

Source match and load match

A TRL* calibration assumes a perfectly balanced test set architecture as shown by the ϵ_{11} term, which represents both the forward source match (E_{SF}) and reverse load match (E_{LR}), and by the ϵ_{22} term, which represents both the reverse source match (E_{SR}) and forward load match (E_{LF}). However, in any switching test set, the source and load match terms are not equal because the transfer switch presents a different terminating impedance as it is changed between port 1 and port 2.

For network analyzers that are based on a three-sampler receiver architecture, it is not possible to differentiate the source match from the load match terms. The terminating impedance of the switch is assumed to be the same in either direction. Therefore, the test port mismatch cannot be fully corrected. An assumption is made that:

forward source match (E_{SF}) = reverse load match (E_{LR}) = ϵ_{11}

reverse source match (E_{SR}) = forward load match (E_{LF}) = ϵ_{22}

For a fixture, TRL* can eliminate the effects of the fixture's loss and length, but does not completely remove the effects due to the mismatch of the fixture. This is in contrast to the "pure" TRL technique used by instruments equipped with four-sampler receiver architecture.

Note: Because the TRL technique relies on the characteristic impedance of transmission lines, the mathematically equivalent method LRM* (for line-reflect-match) may be substituted for TRL*. Since a well-matched termination is, in essence, an infinitely long transmission line, it is well-suited for low (RF) frequency calibrations. Achieving a long line standard for low frequencies is often physically impossible.

How true TRL/LRM works (four-sampler receiver architecture only)

The TRL implementation with four-sampler receiver architecture requires a total of 14 measurements to quantify 10 unknowns, as opposed to only a total of 12 measurements for TRL*. (Both include the two isolation error terms.)

Because of the four-sampler receiver architecture, additional correction of the source match and load match terms is achieved by measuring the ratio of the two "reference" receivers during the thru and line steps. These measurements characterize the impedance of the switch and associated hardware in both the forward and reverse measurement configurations. They are then used to modify the corresponding source and load match terms (for both forward and reverse).

The four-sampler receiver architecture configuration with TRL establishes a higher performance calibration method over TRL* when making in-fixture measurements, because all significant error terms are systematically reduced. With TRL*, the source and load match terms are essentially those of the raw, "uncorrected" performance of the hardware.

Improving raw source match and load match for TRL*/LRM* calibration

A technique that can be used to improve the raw test port mismatch is to add high-quality fixed attenuators as closely as possible to the measurement plane. The effective match of the system is improved because the fixed attenuators usually have a return loss that is better than that of the network analyzer. Additionally, the attenuators provide some isolation of reflected signals. The attenuators also help to minimize the difference between the port source match and load match, making the error terms more equivalent.

With the attenuators in place, the effective port match of the system is improved so that the mismatch of the fixture transition itself dominates the measurement errors after a calibration.

The TRL Calibration

If the device requires bias, it will be necessary to add external bias tees between the fixed attenuators and the fixture. The internal bias tees of the analyzer will not pass the bias properly through the external fixed attenuators. Be sure to calibrate with the external bias tees in place (no bias applied during calibration) to remove their effects from the measurement.

Because the bias tees must be placed after the attenuators, they essentially become part of the fixture. Therefore, their mismatch effects on the measurement will not be improved by the attenuators.

Although the fixed attenuators improve the raw mismatch of the network analyzer system, they also degrade the overall measurement dynamic range.

This effective mismatch of the system after calibration has the biggest effect on reflection measurements of highly reflective devices. Likewise, for well-matched devices, the effects of mismatch are negligible. This can be shown by the following approximation:

$$\begin{aligned} \text{Reflection magnitude uncertainty} &= E_D + E_R S_{11} \\ &+ E_S (S_{11})^2 + E_L S_{21} S_{12} \\ \text{Transmission magnitude uncertainty} &= E_X + E_T S_{21} \\ &+ E_S S_{11} S_{21} + E_L S_{22} S_{21} \end{aligned}$$

where:

- E_D = effective directivity
- E_R = effective reflection tracking
- E_S = effective source match
- E_L = effective load match
- E_X = effective crosstalk
- E_T = effective transmission tracking
- S_{xx} = S-parameters of the device under test

Requirements for TRL standards

When building a set of TRL standards for a microstrip or fixture environment, the requirements for each of these standard types must be satisfied.

Types	Requirements
THRU (Zero length)	No loss. Characteristic impedance (Z_0) need not be known. $S_{21} = S_{11} = 1 \angle 0^\circ$ $S_{11} = S_{22} = 0$
THRU (Non-zero length)	Z_0 of the thru must be the same as the line (if they are not the same, the average impedance is used). Attenuation of the thru need not be known. If the thru is used to set the reference plane, the insertion phase or electrical length must be well-known and specified. If a non-zero length thru is specified to have zero delay, the reference plane is established in the middle of the thru.

Types **Requirements** *(continued)*

REFLECT

Reflection coefficient (Γ) magnitude is optimally 1.0, but need not be known.

Phase of Γ must known and specified to within $\pm 1/4$ wavelength or $\pm 90^\circ$. During computation of the error model, the root choice in the solution of a quadratic equation is based on the reflection data. An error in definition would show up as a 180° error in the measured phase. Γ must be identical on both ports. If the reflect is used to set the reference plane, the phase response must be well-known and specified.

LINE/MATCH (LINE)

Z_0 of the line establishes the reference impedance of the measurement (i.e. $S_{11} = S_{22} = 0$). The calibration impedance is defined to be the same as Z_0 of the line. If the Z_0 is known but not the desired value (i.e., not equal to 50Ω), the SYSTEMS Z_0 selection under the TRL/LRM options menu is used.

Insertion phase of the line must not be the same as the thru (zero length or non-zero length). The difference between the thru and line must be between $(20^\circ \text{ and } 160^\circ) \pm n \times 180^\circ$. Measurement uncertainty will increase significantly when the insertion phase nears 0 or an integer multiple of 180° .

Optimal line length is $1/4$ wavelength or 90° of insertion phase relative to the thru at the middle of the desired frequency span.

Usable bandwidth for a single thru/line pair is 8:1 (frequency span:start frequency).

Multiple thru/line pairs (Z_0 assumed identical) can be used to extend the bandwidth to the extent transmission lines are available.

Attenuation of the line need not be known.

Insertion phase must be known and specified within $\pm 1/4$ wavelength or $\pm 90^\circ$.

LINE/MATCH (MATCH)

Z_0 of the match establishes the reference impedance of the measurement.

Γ must be identical on both ports.

Fabricating and defining calibration standards for TRL/LRM

When calibrating a network analyzer, the actual calibration standards must have known physical characteristics. For the reflect standard, these characteristics include the offset in electrical delay (seconds) and the loss (ohms/second of delay). The characteristic impedance, $OFFSET = Z_0$, is not used in the calculations because it is determined by the line standard. The reflection coefficient magnitude should optimally be 1.0, but need not be known since the same reflection coefficient magnitude must be applied to both ports.

The thru standard may be a zero-length or known length of transmission line. The value of length must be converted to electrical delay, just as for the reflect standard. The loss term must also be specified.

The line standard must meet specific frequency-related criteria, in conjunction with the length used by the thru standard. In particular, the insertion phase of the line must not be the same as the thru. The optimal line length is $\frac{1}{4}$ wavelength (90 degrees) relative to a zero length thru at the center frequency of interest, and between 20 and 160 degrees of phase difference over the frequency range of interest. (Note: these phase values can be

$\pm N \times 180$ degrees where N is an integer.) If two lines are used (LRL), the difference in electrical length of the two lines should meet these optimal conditions. Measurement uncertainty will increase significantly when the insertion phase nears zero or is an integer multiple of 180 degrees, and this condition is not recommended.

For a transmission media that exhibits linear phase over the frequency range of interest, the following expression can be used to determine a suitable line length of $\frac{1}{4}$ wavelength at the center frequency (which equals the sum of the start frequency and stop frequency divided by 2):

$$\text{Electrical length (cm)} = (\text{LINE} - 0 \text{ length THRU})$$

$$\text{Electrical length (cm)} = \frac{(15000 \times VF)}{f1(\text{MHz}) + f2(\text{MHz})}$$

let:

$$f1 = 1000 \text{ MHz}$$

$$f2 = 2000 \text{ MHz}$$

$$VF = \text{Velocity Factor} = 1 \text{ (for this example)}$$

Thus, the length to initially check is 5 cm.

Next, use the following to verify the insertion phase at f1 and f2:

$$\text{Phase (degrees)} = \frac{(360 \times f \times l)}{v}$$

where:

f = frequency

l = length of line

v = velocity = speed of light x velocity factor

which can be reduced to the following, using frequencies in MHz and length in centimeters:

$$\text{Phase (degrees) approx.} = \frac{0.012 \times f(\text{MHz}) \times l(\text{cm})}{VF}$$

So for an air line (velocity factor approximately 1) at 1000 MHz, the insertion phase is 60 degrees for a 5-cm line; it is 120 degrees at 2000 MHz. This line would be a suitable line standard.

For microstrip and other fabricated standards, the velocity factor is significant. In those cases, the phase calculation must be divided by that factor. For example, if the dielectric constant for a sub-

strate is 10, and the corresponding “effective” dielectric constant for microstrip is 6.5, then the “effective” velocity factor equals 0.39 (1 ÷ square root of 6.5).

Using the first equation with a velocity factor of 0.39, the initial length to test would be 1.95 cm. This length provides an insertion phase at 1000 MHz of 60 degrees; at 2000 MHz, 120 degrees (the insertion phase should be the same as the air line because the velocity factor was accounted for when using the first equation).

Another reason for showing this example is to point out the potential problem in calibrating at low frequencies using TRL. For example, ¼ wavelength is:

$$\text{Length (cm)} = \frac{7500 \times VF}{fc}$$

where:

fc = center frequency

Thus, at 50 MHz:

$$\text{Length (cm)} = \frac{7500}{50 (\text{MHz})} = 150 \text{ cm or } 1.5 \text{ m}$$

Such a line standard would not only be difficult to fabricate, but its long term stability and usability would be questionable as well.

Thus at lower frequencies and/or very broad band measurements, fabrication of a “match” or termination may be deemed more practical. Since a termination is, in essence, an infinitely long transmission line, it fits the TRL model mathematically, and is sometimes referred to as a “TRM” calibration.

The TRM calibration technique is related to TRL with the difference being that it bases the characteristic impedance of the measurement on a matched Z_0 termination instead of a transmission line for the third measurement standard. Like the TRL thru standard, the TRM THRU standard can

either be of zero length or non-zero length. The same rules for thru and reflect standards used for TRL apply for TRM.

TRM has no inherent frequency coverage limitations which makes it more convenient in some measurement situations. Additionally, because TRL requires a different physical length for the thru and the line standards, its use becomes impractical for fixtures with contacts that are at a fixed physical distance from each other.

For more information on how to modify calibration constants for TRL/LRM, and how to perform a TRL or LRM calibration, refer to the “Optimizing Measurement Results” in the network analyzer user’s manual.

Using TDR to evaluate fixtures and standards

Time-domain reflectometry (TDR) is a helpful tool. We can distinguish between capacitive and inductive mismatches, and see non- Z_0 transmission lines. TDR can help us determine the magnitude of and distance to reflections of the fixture and the calibration standards. Once the fixture has been designed and fabricated, we can use TDR to effectively evaluate how well we have minimized reflections.

TDR measurements using a vector network analyzer start with a broadband sweep in the frequency domain. The inverse-Fourier transform is used to transform the frequency-domain data to the time-domain, yielding TDR measurements. The spatial resolution is inversely proportional to the frequency span of the measurement. The wider the frequency span, the smaller the distance that can be resolved. For this reason, it is generally necessary to make microwave measurements on the fixture to get sufficient resolution for analyzing the various transmissions.

TDR Basics Using a Network Analyzer

- start with broadband frequency sweep (often requires microwave VNA)
- inverse FFT to compute time-domain
- resolution inversely proportionate to frequency span

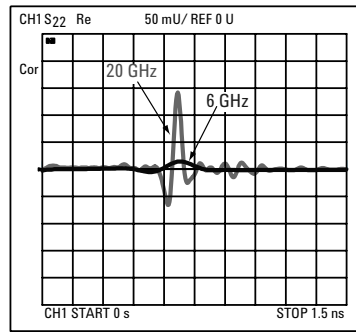

Figure 17.

For example, it may be necessary to measure a fixture designed for use at 3 GHz with a frequency span of 0.05 GHz to 20 GHz or even 40 GHz to get the needed resolution.

Using TDR to Evaluate Fixture and Standards

- what is TDR?
 - time-domain reflectometry
 - analyze impedance versus time
 - distinguish between inductive and capacitive transitions
- with gating:
 - analyze transitions
 - analyzer standards

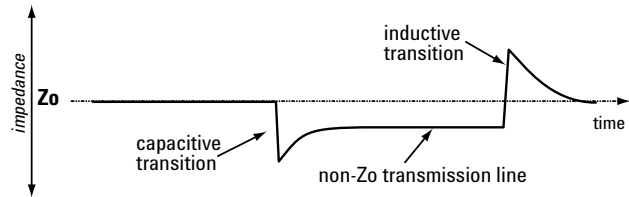
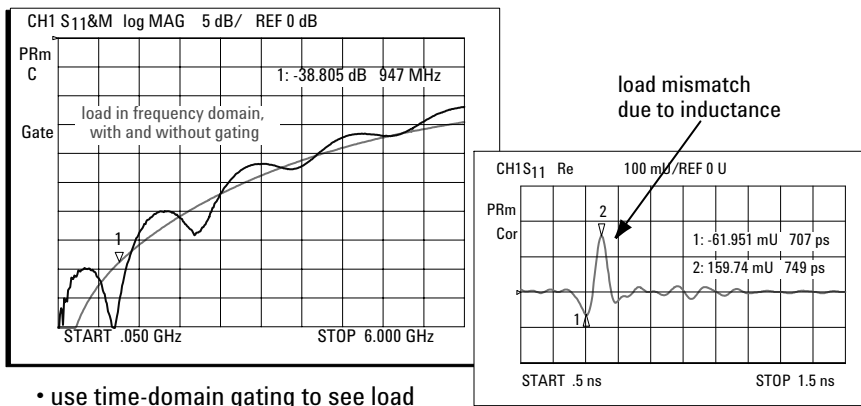

Figure 16.

Time-domain gating can be a very useful tool for evaluating how well the load is performing. We can gate out the response of the fixture and just look at the reflections due to the load standard, provided we can get enough spatial resolution (this may require the use of microwave vector network analyzers). The smoother trace on the plot on the left shows the gated response of a load standard, with a fairly typical match of about 38 dB at 1 GHz, and around 30 dB at 2 GHz. The right-hand plot shows that the load standard looks somewhat inductive, which is fairly typical.

It is possible to adjust our load standard to compensate for the unavoidable parasitic characteristics that degrade the reflection response. Time-domain gating is an excellent tool for helping to determine the proper compensation. For example, we see the effect in both the time and the frequency domains of adding a small capacitance to cancel out some of the inductance of the load standard.

Characterizing and Adjusting Load



- use time-domain gating to see load reflections independent from fixture
- use time domain to compensate for imperfect load (e.g. try to cancel out inductance)

Figure 19.

When using PCB-based fixtures, performance at the connector transition is important, and the consistency between connectors is critical. To minimize the effect of connector mismatch when using multiple connectors on a fixture (a pair for each calibration standard), there must be consistency between the connectors and their mechanical

attachments to the fixture. Time-domain measurements are useful for analyzing both connector performance and repeatability; see Figure 21. For information on making time-domain measurements and using the gating feature, please see your network analyzer user's guide.

Connectors on Fixtures

- transition at the connector launch causes reflection due to mismatch
- when cal standards are inserted in fixture, connector match is removed
- when each cal standard has connectors, consistency is very important

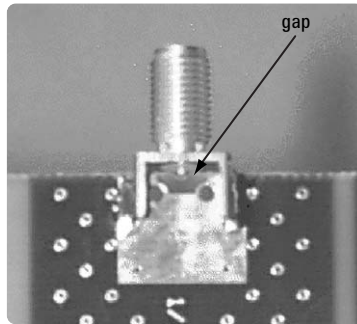
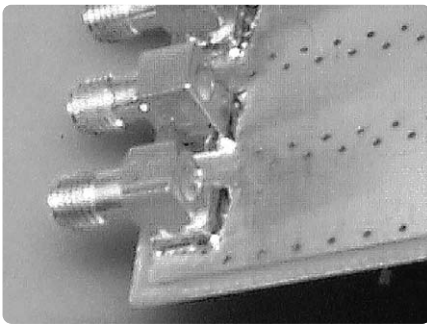
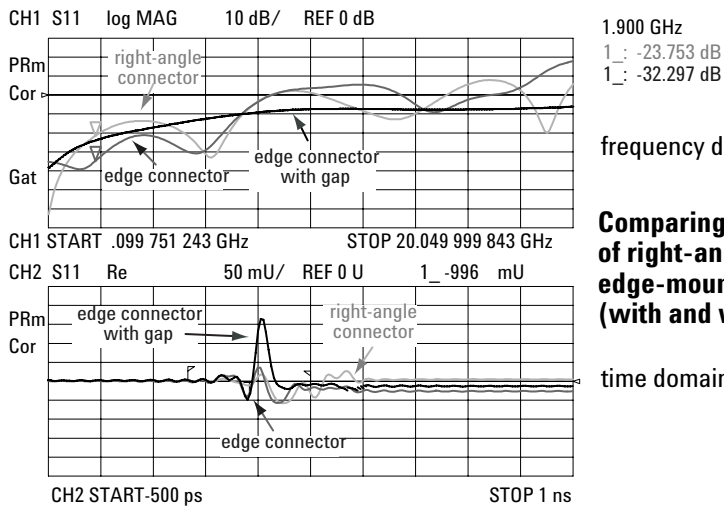

Figure 20.

Connector Performance



Comparing match of right-angle and edge-mount connectors (with and without gap)

Figure 21.

Connector Consistency

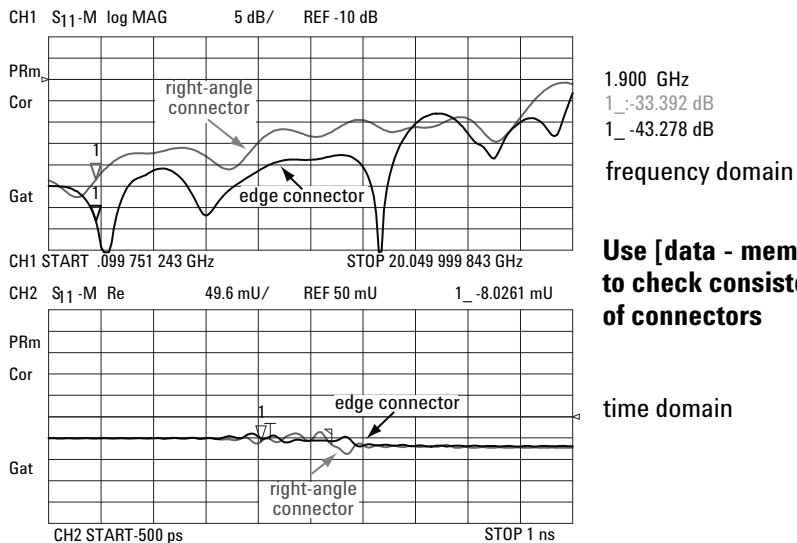

Use [data - memory] to check consistency of connectors

Figure 22.

Biasing active parts

Making in-fixture measurements of active parts requires that DC bias be supplied along with the RF signal. Traditionally, when bias was needed for testing transistors, external bias tees were used in the main RF signal paths. This approach is still valid today although internal bias tees are provided by most vector network analyzers.

Many packaged amplifiers and RFICs require that DC power be supplied on separate pins. This means that the fixture must provide extra connectors, DC feedthroughs, wires, or pins for the necessary bias. These bias connections should present a low DC impedance. Discrete elements can be placed directly on the fixture near the DUT to provide proper RF bypassing and isolation of the DC supply pins. Good RF bypassing techniques can be essential, as some amplifiers will oscillate if RF signals couple onto the supply lines.

Biasing Active Parts

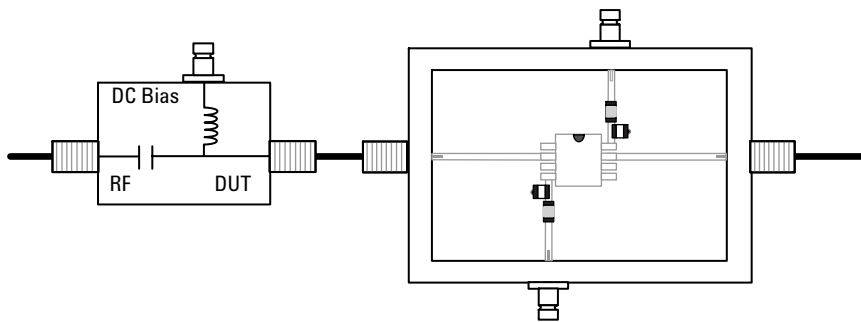

- can use bias-tees if RF and DC share same line (many network analyzers contain internal bias tees)
- if separate, fixture needs extra connectors, pins or wires
- proper bypassing is important to prevent oscillation

Figure 23.

This is an example of how bias could be supplied to a transistor. The power supplies are not shown, but they would be connected to the +V base and the +V collector nodes. The +V base controls the collector current, and +V collector controls the collector-to-emitter voltage on the transistor. For

the base resistors, it is important to use a fairly large value (such as a 10K ohms), so that the voltage adjustment is not too sensitive. You may find it convenient to use two digital voltmeters to monitor the collector current and collector-to-emitter voltage simultaneously.

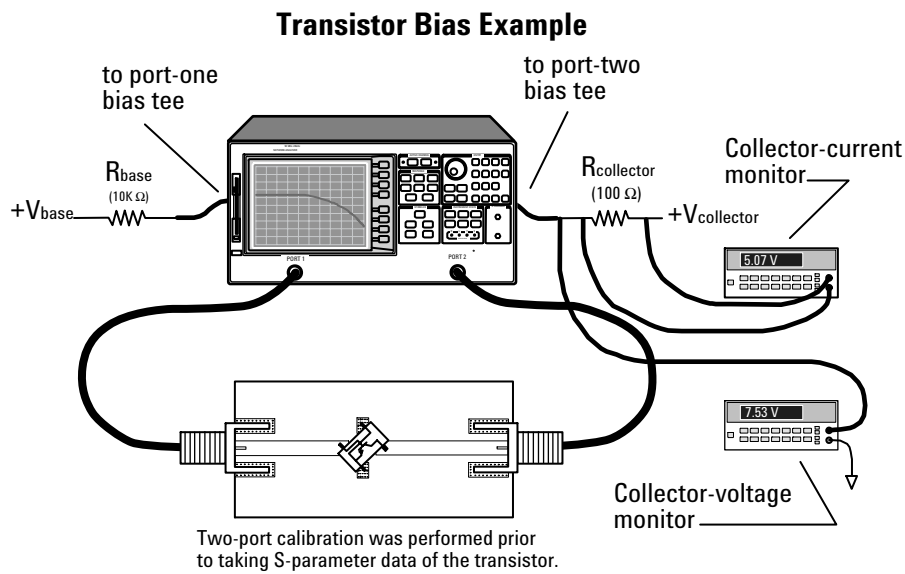

Figure 24.

Conclusion

We have covered the principles of in-fixture testing of components with vector network analyzers. It is time to determine the source of the fixture. Is the fixture available commercially or must it be designed and built? Inter-Continental Microwave is an Agilent Channel Partner experienced in designing and manufacturing test fixtures that are compatible with Agilent network analyzers.

Inter-Continental Microwave contact information:

Inter-Continental Microwave
1515 Wyatt Drive
Santa Clara, CA 95054-1586
Tel: (408) 727-1596
Fax: (408) 727-0105
Fax-on-Demand: (408) 727-2763
Internet: www.icmicrowave.com

If it is necessary to design and build the fixture, more information on calibration kit coefficient modification can be found in the appropriate network analyzer user's manual. A shareware program that simplifies the process of modifying calibration kit coefficients is available at www.vnahelp.com.



Agilent Email Updates

www.agilent.com/find/emailupdates

Get the latest information on the products and applications you select.



Agilent Direct

www.agilent.com/find/agilentdirect

Quickly choose and use your test equipment solutions with confidence.

www.agilent.com

Agilent Technologies' Test and Measurement Support, Services, and Assistance

Agilent Technologies aims to maximize the value you receive, while minimizing your risk and problems. We strive to ensure that you get the test and measurement capabilities you paid for and obtain the support you need. Our extensive support resources and services can help you choose the right Agilent products for your applications and apply them successfully. Every instrument and system we sell has a global warranty. Two concepts underlie Agilent's overall support policy: "Our Promise" and "Your Advantage."

Our Promise

Our Promise means your Agilent test and measurement equipment will meet its advertised performance and functionality. When you are choosing new equipment, we will help you with product information, including realistic performance specifications and practical recommendations from experienced test engineers. When you receive your new Agilent equipment, we can help verify that it works properly and help with initial product operation.

Your Advantage

Your Advantage means that Agilent offers a wide range of additional expert test and measurement services, which you can purchase according to your unique technical and business needs. Solve problems efficiently and gain a competitive edge by contracting with us for calibration, extra-cost upgrades, out-of-warranty repairs, and onsite education and training, as well as design, system integration, project management, and other professional engineering services. Experienced Agilent engineers and technicians worldwide can help you maximize your productivity, optimize the return on investment of your Agilent instruments and systems, and obtain dependable measurement accuracy for the life of those products.



Agilent Open

www.agilent.com/find/open

Agilent Open simplifies the process of connecting and programming test systems to help engineers design, validate and manufacture electronic products. Agilent offers open connectivity for a broad range of system-ready instruments, open industry software, PC-standard I/O and global support, which are combined to more easily integrate test system development.

United States:

(tel) 800 829 4444
(fax) 800 829 4433

Canada:

(tel) 877 894 4414
(fax) 800 746 4866

China:

(tel) 800 810 0189
(fax) 800 820 2816

Europe:

(tel) 31 20 547 2111

Japan:

(tel) (81) 426 56 7832
(fax) (81) 426 56 7840

Korea:

(tel) (080) 769 0800
(fax) (080) 769 0900

Latin America:

(tel) (305) 269 7500

Taiwan:

(tel) 0800 047 866
(fax) 0800 286 331

Other Asia Pacific

Countries:

(tel) (65) 6375 8100
(fax) (65) 6755 0042

Email: tm_ap@agilent.com

Contacts revised: 05/27/05

For more information on Agilent Technologies' products, applications or services, please contact your local Agilent office. The complete list is available at:

www.agilent.com/find/contactus

Product specifications and descriptions in this document subject to change without notice.

© Agilent Technologies, Inc. 1999, 2000, 2006

Printed in USA, January 10, 2006

5968-5329E



Agilent Technologies