

**White Paper**

# Testing Next Generation Core Router Performance



**Agilent Technologies**

## Introduction

Investment in core routers is on the rise. According to Dell'Oro Research, the market for high-end 10G routers was \$260 million in the second quarter of 2004, increasing by 13% quarter over quarter, with Cisco, Juniper and Avici all posting strong revenue increases in the 10 Gbps routers segment. These positive signs of growth indicate that Carriers are not being complacent with their current core network infrastructure and are being very proactive for the next generation of IP/MPLS. A recent Infonetics report<sup>1</sup> identified a strong trend to migrate to IP/MPLS, with 90% of service provider respondents planning to increase expenditures for network-based IP services, and 81% for IP/MPLS networks. It appears the time is finally here for a new upgrade cycle that can equip the core with the scalability and reliability required to deliver voice, video and data services, on demand, over a converged network infrastructure.

Network Equipment Manufacturers have introduced a new breed of core routers that promise to meet service provider scalability and reliability expectations. The price tag for a next generation core routing system can easily reach into the tens of millions. With such a significant capital outlay, carriers want to make sure their getting the best return on their investment. Infonetics reported that 'price-to-performance ratio' and 'product reliability' are the leading criteria considered by service providers when choosing a router and switch manufacturer. However, measuring router performance and reliability these days presents a considerable challenge itself. Qualification cycles for next generation routers are rumored to take upwards of a year. This paper explores the test challenges specifically associated with measuring router performance and recommends test methodologies and guidelines that can help service providers quantify performance limitations and shorten the time it takes to qualify core routing systems. The topic of router reliability and associated performance metrics and test methodologies will be addressed in a separate Agilent whitepaper 'Verifying router reliability and high availability' accessible from [www.agilent.com/comms/N2X](http://www.agilent.com/comms/N2X) in April 2005.

## Measuring Router Performance

Router performance, at least within the core, is most often associated with, and quantified by, scalability. When surveyed, service providers identified scalability as a key determining performance factor when making router purchases.<sup>2</sup> The objective of scalability testing is to expose the limits or boundaries of a device or a network. It is crucial that network architects fully understand scalability thresholds prior to deploying any equipment.

There are many aspects of router scalability to consider. This paper will focus on key scalability metrics being weighed by service providers today including:

- Port scalability
- Traffic scalability
- BGP-4 routing scalability
- MPLS LSP scalability

1. Rob Dearborn et al., Service Provider Plans for IP, MPLS and ATM Networks, North America and Europe 2003 (San Jose: Infonetics Research, 2003), 26.

2. Rob Dearborn et al., Service Provider Plans for IP, MPLS and ATM Networks, North America and Europe 2003 (San Jose: Infonetics Research, 2003), 9.

Quantifying and interpreting scalability can be challenging since there are no standard industry guidelines for what constitutes exceptional, or even acceptable, scalability. However, one would expect that a core router should be capable of meeting traffic and network growth expectations well into the future. For example, the recent test methodology created by EANTC<sup>3</sup> for testing OC-192 and OC-768 routers employed traffic and protocol projections five years into the future.

The remainder of this paper looks at each of the above aspects of router scalability - and corresponding performance metrics, in more detail.

## Port Scalability

Measuring port scalability can be achieved by simply quantifying the physical number of ports that a router can support. This quantity is readily available (or can be calculated) from the available technical specifications of any routing system, and thus requires no further testing or validation. The Cisco Carrier Routing System, for example, reportedly scales to over 1,152 physical OC-768 ports, in a multi-chassis configuration. The Juniper TX Matrix reportedly supports up to 128 physical interface cards (PICs), and the Avici TSR reportedly scales to 40 ports of OC-192 POS or 10GbE. Although a physical port can also support a number of logical ports, ATM, Ethernet and Frame Relay interfaces supporting logical ports are more predominant at the network edge than in the network core, so logical port scalability will not be discussed in the scope of this paper. Typical interfaces supported on next generation core routers today include:

- OC-48c/STM-16c Packet over SONET/SDH
- OC-192c/STM-64c Packet over SONET/SDH
- 10 Gigabit Ethernet

Cisco announced the industry's first OC-768c POS interface on their CRS-1 in 2004 while Avici and Juniper have announced plans to deliver this interface on their core routers in 2005.

## Traffic Scalability

The sum of traffic from data, voice and video service offerings and other sources converging over core networks is expected to increase core IP/MPLS traffic at a rate exceeding 100 percent per year for the next three to five years.<sup>4</sup> Infonetics research shows that "all types of data traffic grow between 2002 and 2004, but IP and IP/MPLS growth is by far the strongest, growing on average 119%, 118%, and 84% year over year, in 2002, 2003, and 2004 respectively."<sup>5</sup>

The aggregate traffic capacity of a core router is function of the physical number of interfaces supported on the routing system. Without counting ingress and egress traffic separately, the Cisco Carrier Routing System reportedly scales to support up to 46-Tbit/s in a multi-chassis

3. EANTC (November 2004). EANTC Light Reading OC-192 and OC-768 Router Test (640 Gbit/s in total) Test Plan Version 2.2. Light Reading: <http://downloads.lightreading.com/2004/11/LR-EANTC-40G-Router-Testplan-2-2.pdf>.

4. Cisco Systems (2004). Next Generation Networks and the Cisco Carrier Routing System. Cisco: [http://www.cisco.com/warp/public/cc/pd/rt/12000/clc/prodlit/reqng\\_wp.pdf](http://www.cisco.com/warp/public/cc/pd/rt/12000/clc/prodlit/reqng_wp.pdf).

5. Rob Dearborn et al., Service Provider Plans for IP, MPLS and ATM Networks, North America and Europe 2003 (San Jose: Infonetics Research, 2003), 7.

## Testing Next Generation Core Router Performance

configuration. Juniper Networks' TX Matrix can be used to combine up to four of the vendor's existing T640 core routers to reportedly support up to 1.28 Tbit/s of traffic (3 billion packets per second). The Avici TSR reportedly scales from 155 megabits to over 5 terabits.

Traffic capacity claims made within marketing documents and technical datasheets presume that every interface on the router is capable of forwarding traffic at wire-rate, with zero packet loss and minimal delay. The specified or theoretical traffic capacity of a routing system should be verified through testing, since actual forwarding performance of the router can vary depending on the traffic parameters and network conditions it's facing at any given time. The number of ports, individual traffic flows, and distribution packet lengths and traffic types across each flow can have varying demands on the router's memory and processing power and ability to forward traffic at wire-rate. Likewise, control plane conditions - such as the number of routing table entries, distribution of network prefix lengths amongst these entries, and stability of the routing table itself can all impact forwarding performance.

### Test Methodology

Router throughput measurements provide the best insight into true scalability limitations. RFC 2544, specified in 1999, provides a good framework for testing the throughput, latency and loss rate of a device; however, the basic principals of this framework must be supplemented with additional testing criteria to better reflect current (and future) Internet conditions.

Testing traffic forwarding performance should be approached methodically. Testing should begin using the most ideal (least stressful) network and traffic parameters. These parameters should be changed so that increasing demands are placed on the router until its breaking point is identified.

In order to fully-load the system under test - be it a new routing card, a single router, chassis or entire multi-chassis system, each interface on the system must be connected to a test equipment interface. This in itself can be a challenging endeavor given the scale of interfaces supported on next generation core routers. The November 2004 OC-192c and OC-768c router test, commissioned and funded by Light Reading, required 58 ports of Agilent N2X test equipment in order to load one fully populated Cisco CRS-1 chassis with 640 Gbits of traffic - probably one of the most massive amounts of IP traffic ever emulated.

The section below describes a variety of test parameters that augment the basic RFC 2544 throughput tests. Key metrics for each area of test include the zero-loss packet rate, percentage of maximum rate, and the minimum, maximum, and average latency.

### Testing with a range of packet sizes

To achieve a baseline forwarding metric, traffic should be sent bi-directionally from every test port to achieve a full traffic mesh in which every port must transmit and receive data simultaneously.

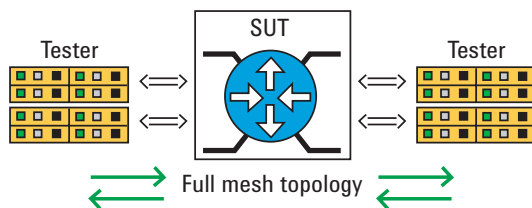

Figure 1: Fully load the SUT

Testing should begin with the large-sized packets and be repeated with incrementally smaller packet sizes until the threshold for wire-rate forwarding is identified. At a minimum the test should be repeated using the frame sizes for different Layer-2 media in RFC 2544: 40, 64, 128, 256, 512, 1024, 1280, and 1500 bytes.

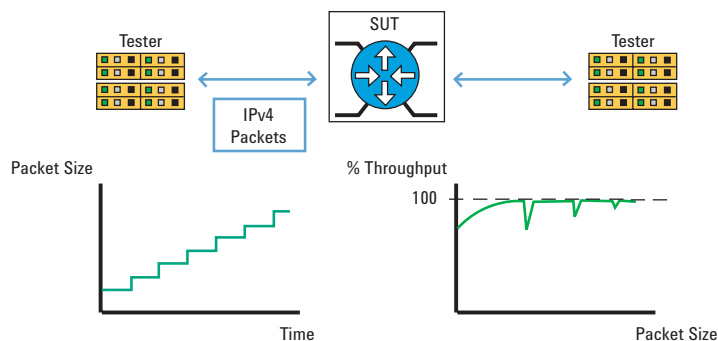

Figure 2: Testing with a range of packet sizes

### Testing with mixed traffic

After testing individual packet sizes sequentially, the router should be subjected to 'realistic' Internet traffic, representative of what is traversing network today. Table 1 illustrates the distribution of IP packet lengths observed in studies by the Cooperative Association for Internet Data Analysis (CAIDA).<sup>6</sup> This traffic distribution, often referred to as 'IMIX traffic', contains a mixture of frame sizes in a ratio to each other and provides the best approximation of the overall composition of frame sizes observed in the real Internet. Flows of IMIX traffic should be generated into the router to fully load every interface while forwarding performance measurements are observed.

Packet size	Percentage
40 bytes	40 %
552 bytes	5 %
576 bytes	6 %
1500 bytes	10 %

Table 1: IPv4 IMIX traffic distribution

6. CAIDA (2000). Packet Length Distributions. [http://www.caida.org/analysis/AIX/plen\\_hist/](http://www.caida.org/analysis/AIX/plen_hist/)

## Testing with IPv6 traffic

"The percentage of IPv6 traffic in the Japanese Internet backbone reached 1 percent of all traffic in 2004. Carriers now require IPv6 for all new backbone equipment. Based on current growth-projections, a worst-case estimation is that IPv6 traffic might reach no more than 15 percent of all Internet traffic until 2010."<sup>7</sup> A representative mix containing 85% IPv4 and 15% IPv6 IMIX traffic should be generated into router to ensure that when fully loaded, the simultaneous processing of IPv4 and IPv6 traffic forwarding does not lead to any performance issues. Table 2 provides an IMIX for IPv6 traffic approximated by EANTC in their test plan for OC-192 and OC-768 routers.<sup>8</sup>

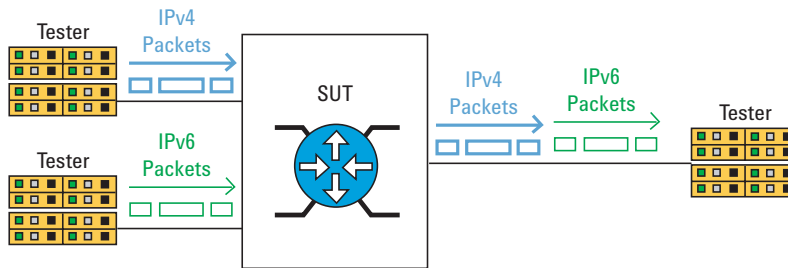

Figure 3: Ipv4 Ipv6 Traffic Forwarding Test

Packet size	Percentage
64 bytes	38 %
174 bytes	23 %
750 bytes	16 %
1500 bytes	23 %

Table 2: Approximated IPv6 IMIX traffic distribution

7. Light Reading (Nov 2004). 40-Gig Router Test Results. [http://www.lightreading.com/document.asp?site=lightreading&doc\\_id=63606&page\\_number=4](http://www.lightreading.com/document.asp?site=lightreading&doc_id=63606&page_number=4).

8. EANTC (November 2004). EANTC Light Reading OC-192 and OC-768 Router Test (640 Gbit/s in total) Test Plan Version 2.2. Light Reading:<http://downloads.lightreading.com/2004/11/LR-EANTC-40G-Router-Testplan-2-2.pdf>.

## Testing with a large number of traffic flows

A traffic flow refers to a series of packets sharing the same source and destination address pair. Each traffic flow represents a unique user. Increasing the number of traffic flows per interface can affect the forwarding performance of certain router architectures since it impacts the size of a flow table, and the speed of accessing the table entries. Therefore, the above traffic tests should use multiple flows per interface. For example, to test the forwarding performance of the Cisco CRS-1 40G router, EANTC used the Agilent N2X to generate 15 million traffic flows (each emulating an individual user consuming 42 kbit/s bandwidth) across 58 interfaces to fill 640 Gbit/s. This number of flows greatly exceeds today's requirements, and accordingly to service provider feedback, is a good number.<sup>9</sup>

## Additional packet processing and prioritization

As traditional Layer 3 networks are converted into a more revenue-generating networks, with new product and service offerings, core routers must have the ability to differentiate and deliver different classes of service on demand. "Converged packet infrastructures will carry tens of millions of simultaneous data flows, video streams, and voice conversations throughout any given day. Some of these will be high-priority, high-value flows with strict delay, loss, and jitter requirements, others will be critical business transactions that must be rerouted instantly around any network disruptions, and others may be ordinary HTTP or Simple Mail Transfer Protocol (SMTP) flows that require and expect nothing more than best-effort service. The ability to distinguish and properly service each flow according to its individual requirements will require rich, scalable packet- and flow-classification mechanisms and thousands of queues per interface to provide priority forwarding and congestion management."<sup>10</sup>

It is important to measure whether additional packet-processing services compromise traffic forwarding performance, and whether the router can maintain wire-rate throughput for high-priority traffic when burdened with traffic prioritization under congestion.

## Testing with packet processing features enabled

It is a standard requirement for a carrier-class router to meet traffic scalability/forwarding performance expectations when additional packet processing features like differentiated services classification, access control filters and access control list logging are activated. IPv4/IPv6 traffic forwarding tests should be repeated with these services enabled to ensure there is no impact on resulting forwarding performance, however, UDP packets (48 bytes) should be sent instead of IP packets to force the router to inspect UPD headers for access control list processing.

QoS classification filters should be configured on every router interface. A typical scenario requires 500 filter entries for both IPv4 and IPv6 to emulate customers assigned to different classes of service.

Access control lists (ACLs) for both IPv4 and IPv4 should be configured in such a way that the router is forced to process all statements and look deeply into the packet before making a forwarding decision. Access criteria should be pseudo-random to prevent sequential ranges being converted into a single ACL entry. The number of entries in the ACLs should be of sufficient scale to stress the router's processing capabilities.

9. Light Reading (Nov 2004). 40-Gig Router Test Results. [http://www.lightreading.com/document.asp?site=lightreading&doc\\_id=63606&page\\_number=3](http://www.lightreading.com/document.asp?site=lightreading&doc_id=63606&page_number=3).

10. Cisco Systems (2004). Next Generation Networks and the Cisco Carrier Routing System. Cisco: [http://www.cisco.com/warp/public/cc/pd/rt/12000/clc/prodlit/reqng\\_wp.pdf](http://www.cisco.com/warp/public/cc/pd/rt/12000/clc/prodlit/reqng_wp.pdf).

For reference, when testing the Cisco CRS-1, EANTC used a 5,001-entry ACL for both IPv4 and IPv6<sup>11</sup>. For routers with both ingress and egress service policies, an ingress and egress filter should be applied on each router port to ensure that the ACLs are processed twice for each packet.

**Testing during traffic prioritization**

Under congestions, a router will make traffic prioritization and queuing decisions based on differentiated services markings on the packets. Table 3<sup>12</sup> provides an example of how to assign different priority levels to IPv4 traffic being generated into the router. (Note: IPv6 does not use Diffserv in the same way.)

Diffserv Class	Diffserv Name	Class Name	Packet Size
EF	Expedited Forwarding	Premuim	60 Byte
AF11	Assured Forwarding Class 1	Gold	40 Byte
AF21	Assured Forwarding Class 2	Silver	552 Byte
AF31	Assured Forwarding Class 3	Bronze	576 Byte
BE	Best Effort	Best Effort	1500 Byte

**Table 3: Differentiated Services Traffic Mix**

Once configured with Diffserv Codepoints, IPv4 traffic should be generated into the router so that the transmit bandwidth exceeds the bandwidth capacity of the router ports. This over-subscription will force the router to prioritize the traffic accordingly. The key scalability metric to consider is whether the router is capable of maintaining wire-rate forwarding for the highest priority traffic, at the expense of lower traffic, when ports are over-subscribed.

11. Light Reading (Nov 2004). 40-Gig Router Test Results. [http://www.lightreading.com/document.asp?site=lightreading&doc\\_id=63606&page\\_number=5](http://www.lightreading.com/document.asp?site=lightreading&doc_id=63606&page_number=5)

12. Light Reading (Nov 2004). 40-Gig Router Test Results. [http://www.lightreading.com/document.asp?site=lightreading&doc\\_id=63606&page\\_number=8](http://www.lightreading.com/document.asp?site=lightreading&doc_id=63606&page_number=8)

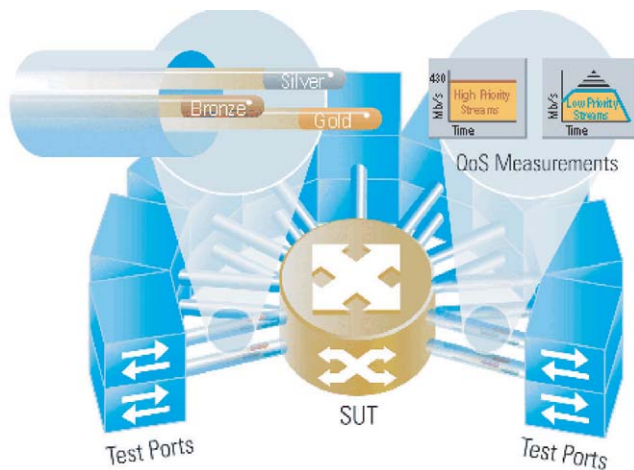

Figure 4: Testing during traffic prioritization

### Testing with bursty traffic

Measuring forwarding performance under steady state load is not realistic since a typical traffic source within the Internet generally does not transmit data at a constant bandwidth - http and voice traffic, in particular, are characteristically bursty, whereas ftp traffic (which constitutes only 5% of traffic within the Internet) is typically less bursty and more constant. The above tests should be performed with both steady state traffic and with traffic consisting of repeated bursts of frames.

### Testing during routing instability

The above traffic scalability tests assume that the control plan within the router remains constant and stable, however, in the real-life Internet, core routing tables are constantly being updated to reflect network topology changes and routing instability inherent in networks today. Thus, it is important to measure whether the router can maintain wire-rate traffic forwarding while processing routing updates from the tester, and while the tester flaps the routes over which the router is forwarding traffic.

## BGP-4 Routing Scalability

BGP routing scalability refers to the number of total number of BGP-4 routes and peers that a router can support. Next generation core routers must have the processing power capable of maintaining thousands of BGP routes and peers.

### Test Methodology

#### Maximum Number of BGP-4 routes

The purpose of this test is to identify the maximum number of BGP-4 routes that the router can learn and maintain within its routing table. Discovering this threshold is a multi-step process. First, a large number of IPv4 routing entries should be advertised into the router. Figure 5<sup>13</sup> shows the growth of routes visible from one autonomous system (Telstra - AS 1221) from 1989 to present. The BGP routing table currently contains approximately 180,000 routes. Last year the number of BGP table entries increased by roughly 20,000 routes, and individual entries are growing at an increasing rate. As mentioned earlier, test parameters should reflect network expectations well into the future.

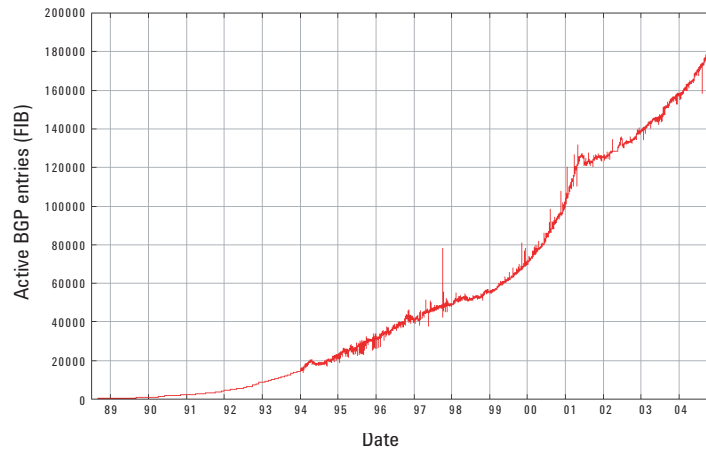

**Figure 5: The growth of BGP routing table entries <sup>13</sup>**

The BGP entries themselves should be realistic in terms of the distribution of network prefix lengths. Networks connected to the Internet are varied in size, which is reflected in the variance of network prefix lengths within the routing tables of the router. The number of different-length prefixes found within the router can affect the time it takes to perform a longest length prefix match to find the destination interface corresponding to an IP packet destined for a particular network. Most network prefix lengths found within the routing tables within the Internet core are between 16 and 24 bits in length. Figure 6<sup>14</sup> shows the percentage distribution of network prefixes in core BGP tables today.

13. Figure 5: BGP table size from AS1221 as of Dec 9, 2004, Telstra, <http://bgp.potaroo.net/as1221/bgp-active.html>

14. Figure 6: AS1221 table data as of Dec 9, 2004, Telstra, <http://bgp.potaroo.net/as1221/bgp-active.html>

(Note:prefix lengths with a percentage distribution below 1% aren't shown in this graph.)

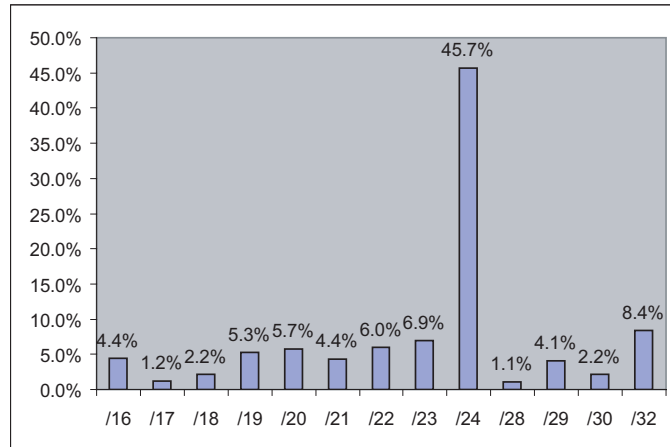

Figure 6: Distribution of BGP table entries by address prefix length 14

After the router has successfully processed the routing table entries, the traffic should be forwarded over these routes for validation. Since routers have only a finite amount of memory and processing power there will be a threshold where the router will not be able to process any additional routes. Additional routing entries should be advertised to the router (followed by traffic validation) until the router is incapable of processing additional routes, and the BGP route scalability limit is determined.

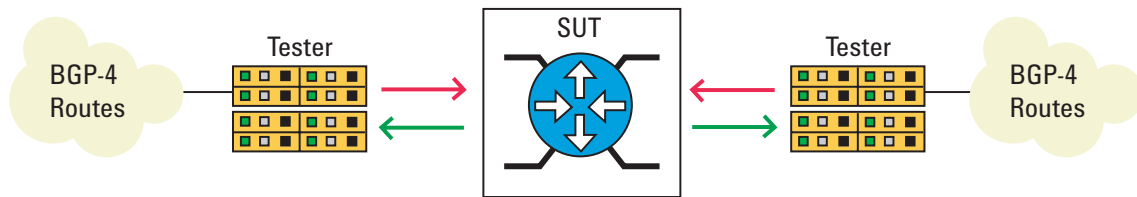

Figure 7: Advertise BGP router and traffic into the SUT

## BGP peer capacity

A core Internet router exchanges routing information with BGP peer routers both within and outside of its autonomous system. The number of BGP peering relations that a core router must maintain can easily reach into the hundreds (or thousands in a multi-chassis configuration), and processing routing updates from this many neighbors can place a significant processing demand on the router.

The purpose of this test is to identify the maximum number of BGP peer routers that the router can manage from an information exchange perspective. A representative number of BGP peer routers, each advertising unique routing table, must be emulated around the core router. The router should be capable of transmitting traffic in a full mesh across the emulated routers. The number of emulated BGP peers and routing table entries should be increased until the router is no longer capable of forwarding traffic across the emulated routes at wire-speed and the BGP peering scalability limit is reached. For reference, when testing the BGP peering capabilities of the Cisco CRS-1, EANTC used the Agilent N2X to emulate 58 peer routers, advertising a total of 1.5 million unique IPv4/IPv6 routing table entries in order to take into consideration the growing rate of BGP table entries, internal customer routes not seen by the Internet, and the growth of IPv6 routing tables.<sup>15</sup>

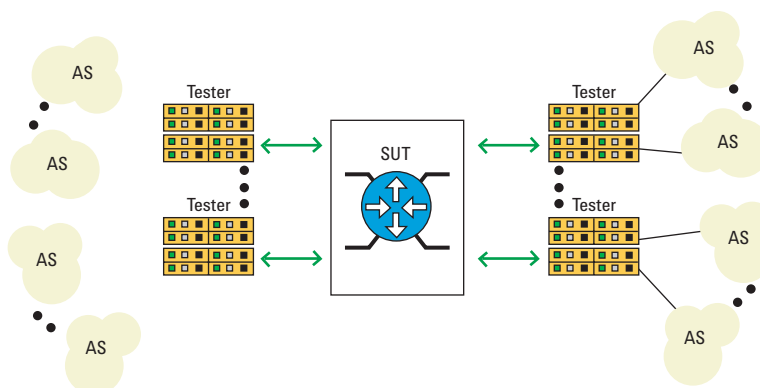

Figure 8: Testing BGP peer capacity

## MPLS Scalability

MPLS scalability within a core MPLS label switch router (LSR) refers to the number of label-switched paths (LSPs) it can maintain. With data network convergence and the goal of a service-agnostic MPLS core, LSP scalability is becoming an increasingly important core router feature. When surveyed by Infonetics, service providers rated LSP scalability higher than any other feature they wanted to see in core routers.<sup>16</sup>

15. AS1221 table data as of Dec 9, 2004, Telstra, <http://bgp.potaroo.net/as1221/bgp-active.html>

16. Rob Dearborn et al., Service Provider Plans for IP, MPLS and ATM Networks, North America and Europe 2003 (San Jose: Infonetics Research, 2003), 9.ml

## Test Methodology

Use a tester to simulate an OSPF or IS-IS network topology behind ports on the router, and to establish bi-directional LSPs using either LDP or RSVP-TE between the endpoints in the simulated topologies. For reference, EANTC used the Agilent N2X to establish 1500 bi-directional RSVP-TE LSPs between each set of ports, to establish a total of 57,000 RSVP-TE tunnels across the Cisco CRS-1 in the Light Reading 40G Router Test.<sup>17</sup> Once the LSPs are established, use the tester to generate bi-directional labeled traffic across the LSPs for tunnel validation. The number of emulated LSPs should be increased until the router can't establish any additional LSPs, or until the router no longer switches labeled packets to the correct LSP.

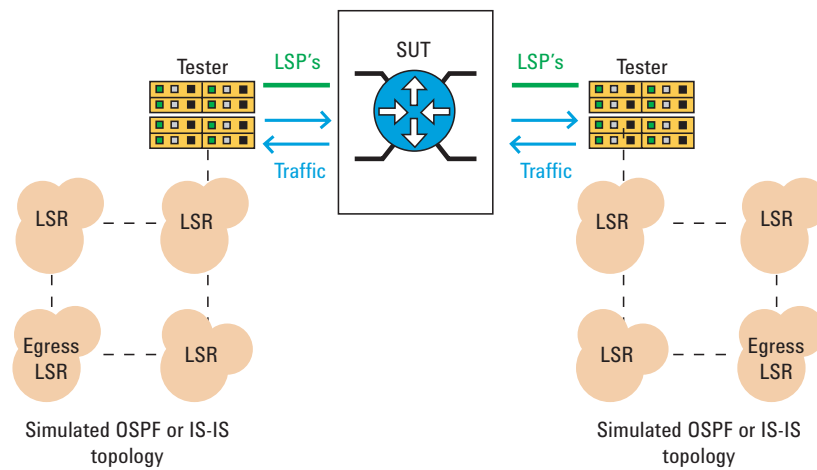

Figure 9: Maximum number of Label Switched Paths

17. Light Reading (Nov 2004). 40-Gig Router Test Results. [http://www.lightreading.com/document.asp?site=lightreading&doc\\_id=63606&page\\_number=10](http://www.lightreading.com/document.asp?site=lightreading&doc_id=63606&page_number=10).

## **Conclusion**

Capex expenditure for core network upgrades is on the rise. Router vendors have announced the next generation of core routing equipment that claim to deliver unprecedented levels of scalability and reliability. With significant capital outlay and the ability to deliver revenue-generating IP services at stake, service providers must be much more proactive and diligent in their qualification and evaluation of core routing devices. It is imperative that service providers fully understand the limitations of each network device prior to deployment. The sheer scale and complexity of today's core router makes verifying performance claims a daunting – but critical task.

This paper identified some of the key router scalability measurements and test parameters that service providers should consider today, but is by no means a comprehensive reference for core router qualification. Scalability testing is just one component of router qualification, and must be supplemented by the functional validation of system features and components, as well as interoperability testing with other vendor equipment. With a drive to deploy time-sensitive and mission-critical IP services across the network core, measuring router reliability and stability is becoming an increasingly important – and challenging area of test as well.

Partnering with an experienced test equipment vendor can greatly facilitate the router qualification process. A router tester should be scalable and flexible enough to quickly perform all types of router performance, functional, interoperability and reliability testing. A test vendor with industry-proven experience and test leadership can provide the test methodologies and automated tools to help expedite complex test configurations and shorten the time it takes to comprehensively qualify a next generation core router.

This page intentionally left blank.

**United States:**

Agilent Technologies  
Test and Measurement Call Center  
P.O. Box 4026  
Englewood, CO 80155-4026  
1-800-452-4844

**Canada:**

Agilent Technologies Canada Inc.  
2660 Matheson Blvd. E  
Mississauga, Ontario  
L4W 5M2  
1-877-894-4414

**Europe:**

Agilent Technologies  
European Marketing Organisation  
P.O. Box 999  
1180 AZ Amstelveen  
The Netherlands  
(31 20) 547-2323  
United Kingdom  
07004 666666

**Japan:**

Agilent Technologies Japan Ltd.  
Measurement Assistance Center  
9-1, Takakura-Cho, Hachioji-Shi,  
Tokyo 192-8510, Japan  
Tel: (81) 426-56-7832  
Fax: (81) 426-56-7840

**Latin America:**

Agilent Technologies  
Latin American Region Headquarters  
5200 Blue Lagoon Drive, Suite #950  
Miami, Florida 33126  
U.S.A.  
Tel: (305) 269-7500  
Fax: (305) 267-4286

**Asia Pacific:**

Agilent Technologies  
19/F, Cityplaza One, 1111 King's Road,  
Taikoo Shing, Hong Kong, SAR  
Tel: (852) 3197-7777  
Fax: (852) 2506-9233

**Australia/New Zealand:**

Agilent Technologies Australia Pty Ltd  
347 Burwood Highway  
Forest Hill, Victoria 3131  
Tel: 1-800-629-485 (Australia)  
Fax: (61-3) 9272-0749  
Tel: 0-800-738-378 (New Zealand)  
Fax: (64-4) 802-6881

[www.agilent.com/comms/n2x](http://www.agilent.com/comms/n2x)

Copyright © Agilent Technologies, Inc. 2005  
Specifications subject to change  
5989-2733EN April 8, 2005

