

Agilent N2X
**MPLS OAM Protocol
Emulation Software**

E7879A
Technical Data Sheet



The most comprehensive tool to automatically verify the operation, performance and scalability of LSP Ping implementations; monitor the health of MPLS systems; and identify and resolve MPLS problems more quickly and with greater confidence.

Key Features

- **LSP Ping protocol emulation**
- **Automatically send Ping Echo requests to validate the status of active LSPs**
- **Automatically send Traceroute requests to report LSP hop-by-hop information**
- **Accurately measure Ping roundtrip latency**
- **Fully integrated with N2X RSVP-TE and LDP signalling**
- **Works with N2X's wire-speed traffic generator/analyzer**

Product Overview

Agilent N2X is the industry's most comprehensive test solution for testing the development and deployment of network services for converging network infrastructures. Service providers, network equipment manufacturers (NEMs), and component manufacturers can verify service attributes of entire networks end-to-end, while also isolating problems down to individual networking devices and subsystems.

Agilent N2X delivers unparalleled test realism to verify the ultimate performance, scalability and resilience of carrier grade services and infrastructure.

Agilent N2X MPLS OAM Protocol Emulation software provides a comprehensive and scalable solution to verify the correct operation of MPLS label switched paths.

N2X can not only be used to validate the implementation of LSP Ping functionality but can also be an integral tool in helping troubleshoot and maintain MPLS networks and devices. By emulating the LSP Ping protocol, N2X can generate, analyse and measure ping and traceroute Echo requests to detect and isolate LSP faults.

Agilent N2X MPLS OAM Protocol Emulation software works in conjunction with the N2X MPLS Signalling Emulation software to provide a single comprehensive MPLS test solution. MPLS LSPs can be dynamically established or maintained using the N2X RSVP-TE or LDP/CR-LDP emulation. Additionally, wire-speed labelled data traffic can be generated across those LSPs and their status can be monitored using N2X LSP Ping emulation.

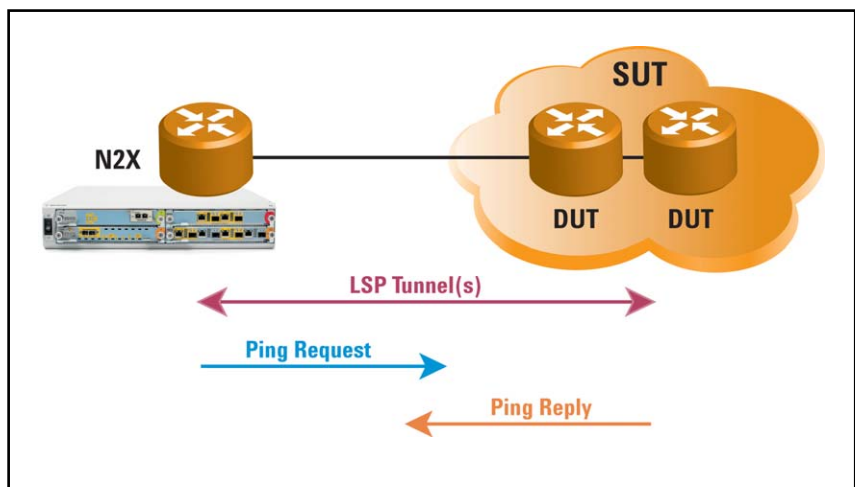

Figure 1: Verifying Label Switched Path status using MPLS LSP Ping

Product Features

Validating LSP Ping Functionality

The N2X MPLS OAM Protocol Emulation software can test the implementation of the LSP Ping protocol within a device or system for functionality, scalability and performance.

- **MPLS OAM functionality**

Verify the accuracy of Ping response timing statistics and Trace response data. Ensure that correct messages are returned from each type of Echo request, from each SUT interface, and for different types of LSP tunnels established using a mixture of RSVP-TE and LDP.

- **Negative testing**

Verify SUT stability and uncover potential interworking or security issues by testing under abnormal conditions. Send Echo requests to SUT interfaces for LSPs that are inactive or non-existent. Use the PDU Builder to generate customized packets to verify the SUT's response to incorrectly formed packets, non-conforming packets, illegal values, and unexpected messages.

- **Impact on data plane performance**

Load data paths (active LSPs through the SUT) by generating wire-speed traffic, and verify that each packet is correctly forwarded through the SUT to the target egress interface with correct label switching. Gauge the impact of high data volumes on the ability of the device to reply correctly and in a timely manner to LSP Ping Echo requests. Conversely, measure the impact of large volumes of ping requests on the ability of the SUT to forward traffic, and on the traffic forwarding performance (packet throughput, loss, latency and latency variation).

- **Scalability**

Scale up the test to verify stability under load and characterize the SUT's maximum performance limits. Use N2X to send thousands of MPLS OAM messages at high request rates, for large meshes of active LSP tunnels, across multiple test interfaces at the same time.

- **Impact on control plane performance**

Test MPLS signalling and OAM performance in conjunction with routing performance. In many devices, routing and MPLS signalling protocols are processed within the same CPU or hardware card. Stress the routing, signalling and OAM capabilities simultaneously by simulating large networks of routing peers or adjacencies using multiple routing protocols; establishing multiple RSVP and LDP tunnels; flapping a subset of the routes and tunnels; and sending (and checking the responses to) multiple LSP ping and trace requests through the other tunnels at the same time.

Troubleshooting MPLS Label Switched Paths

The N2X MPLS OAM Protocol Emulation software can be used during any test scenario that involves MPLS to monitor and diagnose faults within active label switched paths. MPLS is a technology now used to speed packet forwarding, implement QoS and high availability in packet switched networks, and enable services such as VPNs and Multicast. Here are some example test areas in which LSP Ping has become an important tool to accelerate testing and troubleshooting:

- **Switching and Signalling**
Verify MPLS RSVP-TE, LDP and CR-LDP protocols. Test Label Edge Routers (LERs) and Label Switched Routers (LSRs). Measure LSP setup time and characterize MPLS scalability.
- **High Availability**
Gauge MPLS Fast Re-Route / LSP Switchover time, Make-Before-Break and Tunnel Pre-emption.
- **IPv6 Transition**
Test IPv6 BGP/MPLS tunnelling operation and scalability.
- **Pseudo-wire and VPN Services**
Verify the functionality and performance of BGP/MPLS layer-3 VPNs, Pseudo-wires (PWE3), L2oMPLS (layer 2) VPNs, Virtual Private Wire Services (VPWS) and Virtual Private LAN Services (VPLS). Validate Provider (P), Provider Edge (PE) and Customer Edge (CE) routers, and quantify service scalability.
- **Multicast Services**
Confirm the establishment, stability and tear-down of multicast VPNs.

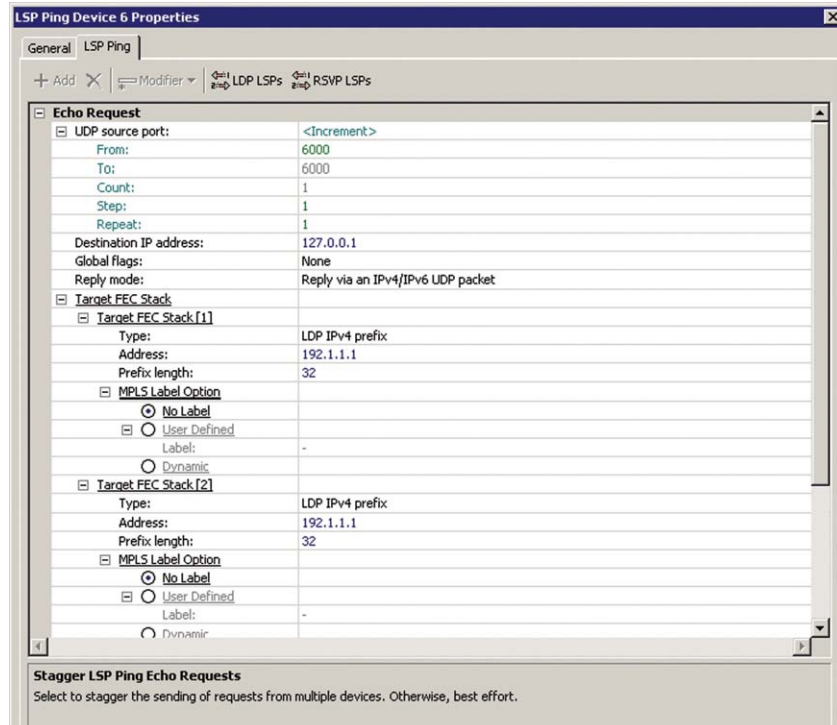

Figure 2: LSP Ping Echo Requests from Multiple Simulated Devices can be Staggered or Sent as Best Effort

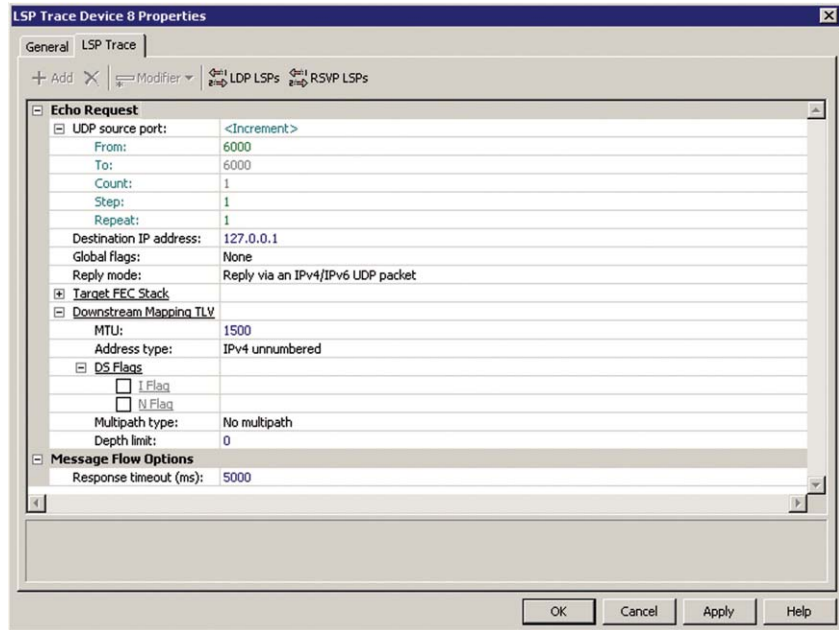

Figure 3: LSP Ping Trace Messages can Verify LDP and RSVP Tunnels

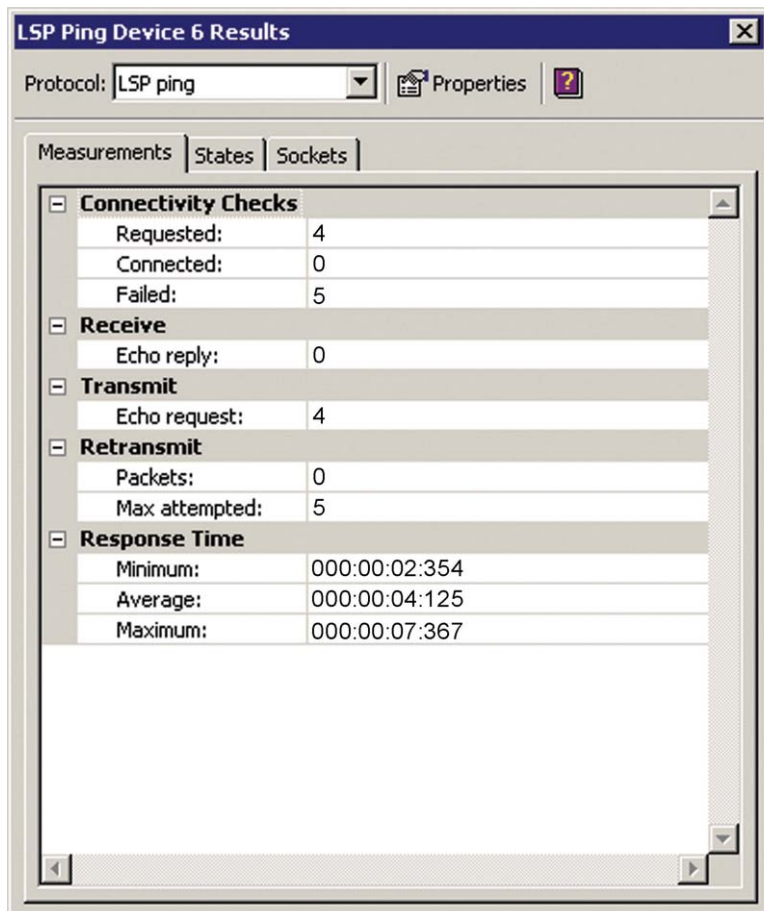

Figure 4: LSP Ping Results Comprehensively Characterize Tunnel Status and Performance

Technical Specifications

LSP Ping Configurable Parameters

- LSP Ping Mode**
 - Ping
 - Trace
- LSP Ping Options**
 - Source UDP port
 - Destination IP address
 - Global flags
 - Reply mode
 - Target FEC TLV (multiple)
 - Downstream mapping TLV
- Target FEC TLV**
 - LDP IPv4 prefix
 - LDP IPv6 prefix
 - RSVP IPv4 LSP
 - RSVP IPv6 LSP
 - VPN IPv4 prefix
 - VPN IPv6 prefix
 - L2 VPN endpoint
 - FEC 128 pseudowire (deprecated)
 - FEC 128 pseudowire
 - FEC 129 pseudowire
 - BGP labeled IPv4 prefix
 - BGP labeled IPv6 prefix
 - Generic IPv4 prefix
 - Generic IPv6 prefix
 - Nil FEC
- Timers**
 - Ping request transmit interval (ms)
 - Connectivity check interval (ms)
 - Retransmit attempts
 - Response timeout (ms)

LSP Ping Statistics

- Individual LSP**
 - Current LSP Ping state (connected/disconnected/idle/requesting)
 - Round trip latency
 - Failure summary (return code/return sub-code)
 - Connectivity counters: requested, connected, failed
 - Echo Reply packets received
 - Echo Request packets sent
 - Retransmitted Ping packets
- Pool of LSPs**
 - Connectivity counters: requested, connected, failed
 - Echo Reply packets received
 - Echo Request packets sent
 - Retransmitted Ping packets
 - Round trip latency: min, max, average
 - LSP ping state counters: connected, disconnected, idle, requesting
- Trace**
 - Fault isolation counters: attempted, connected, failed
 - Echo Reply packets received
 - Echo Request packets sent
 - Round trip latency: min, max, average
 - Received Downstream Mapping information will be reported on a hop-by-hop basis

Additional N2X Features

Easy-to-use Graphical User Interface

The graphical user interface provides simple point and click features to dynamically generate LSP Ping or Traceroute requests. The results of the requests are also displayed graphically to allow the status of LSPs to be determined at a glance.

Agilent N2X's flexible PDU Builder, multi-protocol emulation environment and interactive user interface make N2X the most realistic solution capable of simulating an environment accurately reflecting the complexity and volatility of live networks.

Generate wire-speed traffic

Using the wire-speed traffic capability of the N2X Packets and Protocols application, you can generate a complex, real-world mix of traffic while simultaneously testing routing and signalling functionality. For example, LSP tunnels can be created and the data forwarding performance of the labelled packets traversing those tunnels can be measured while still actively monitoring the state of the tunnels using LSP Ping requests.

Tcl application programming interface

Automation of test scenarios is made simple through Agilent's easy-to-use application programming interface (API). The Tcl-based API enables the user to create automated test sequences or pre-defined test configurations. Tcl scripts can run on the N2X System Controller, a remote PC, or UNIX workstation attached to the Controller via a TCP/IP connection.

Capture and Protocol Decode

Problem isolation and troubleshooting is simple using the N2X comprehensive capture and protocol-decode analyzer. This enables measurements to be investigated offline to expose the performance and functional limitations of a System Under Test (SUT). Users can display a comprehensive protocol-decoded view of captured packets, including LSP Ping and Traceroute messages, and investigate issues in more detail than can be provided in real-time.

Data can be analysed by manipulating a graphical representation of an entire capture buffer. Users simply select a point of interest, such as a spike in latency, and then drill down by re-analyzing the location around the selected point, until the packet of interest has been isolated.

Applicable Standards

“Detecting Multi-Protocol Label Switched (MPLS) Data Plane Failures” – IETF RFC 4379

Online Help

An extensive online help system provides complete descriptions and detailed usage instructions for every component of N2X. Dialog-level, context-sensitive help provides rapid access to the relevant sections of the online help.

Configuration and Ordering Details

To use the E7879A MPLS OAM Protocol Emulation software, the following Agilent N2X hardware and software are required.

Hardware

A N2X system is required with:

- System controller
- Chassis
- Interface cards

E7879A MPLS OAM Protocol Emulation software is supported on all N2X XR, XR-2, XS and XS-2 test cards.

E7879A MPLS OAM Protocol Emulation software is NOT supported on N2X XP test cards.

Software

Required software packages:

- E7881B Packets and Protocols Application Software
- E7883A MPLS Signalling Emulation Software

Your local Agilent field engineer can provide more details on how to order and configure a test system.

Related Products

The Agilent Network Tester is a highly scalable and flexible solution for performance testing of Layer 4-7 devices. As a companion to N2X, the NetworkTester provides real-world, stateful application layer traffic generation over PPP sessions, enabling developers to verify the end-user experience and performance of applications running over a broadband network. It also supports 802.1x, IPsec and IPsecv6 access protocols.



Agilent N2X

Agilent's N2X multi-service tester combines leading-edge services with carrier grade infrastructure testing and emulation. The N2X solution set allows network equipment manufacturers and service providers to more comprehensively test new services end-to-end, resulting in higher quality of service and lower network operating costs.

Warranty and Support

Hardware Warranty

All N2X hardware is warranted against defects in materials and workmanship for a period of 1 year from the date of shipment.

Software Warranty

All N2X software is warranted for a period of 90 days. The applications are warranted to execute and install properly from the media provided. This warranty only covers physical defects in the media, whereby the media is replaced at no charge during the warranty period.

Software Updates

With the purchase of any new system controller Agilent will provide 1 year of complimentary software updates. At the end of the first year you can enroll into the Software and Support Agreement (SSA) contract for continuing software product enhancements.

Support

Technical support is available throughout the support life of the product. Support is available to verify that the equipment works properly, to help with product operation, and to provide basic measurement assistance for the use of the specified capabilities, at no extra cost, upon request.

Ordering Information

To order and configure the test system consult your local Agilent field engineer.

Sales, Service and Support

United States:

Agilent Technologies
Test and Measurement Call Center
P.O. Box 4026
Englewood, CO 80155-4026
1-800-452-4844

Canada:

Agilent Technologies Canada Inc.
2660 Matheson Blvd. E
Mississauga, Ontario
L4W 5M2
1-877-894-4414

Europe:

Agilent Technologies
European Marketing Organisation
P.O. Box 999
1180 AZ Amstelveen
The Netherlands
(31 20) 547-2323

United Kingdom

07004 666666

Japan:

Agilent Technologies Japan Ltd.
Measurement Assistance Center
9-1, Takakura-Cho, Hachioji-Shi,
Tokyo 192-8510, Japan
Tel: (81) 426-56-7832
Fax: (81) 426-56-7840

Latin America:

Agilent Technologies
Latin American Region Headquarters
5200 Blue Lagoon Drive, Suite #950
Miami, Florida 33126
U.S.A.
Tel: (305) 269-7500
Fax: (305) 267-4286

Asia Pacific:

Agilent Technologies
19/F, Cityplaza One, 1111 King's Road,
Taikoo Shing, Hong Kong, SAR
Tel: (852) 3197-7777
Fax: (852) 2506-9233

Australia/New Zealand:

Agilent Technologies Australia Pty Ltd
347 Burwood Highway
Forest Hill, Victoria 3131
Tel: 1-800-629-485 (Australia)
Fax: (61-3) 9272-0749
Tel: 0-800-738-378 (New Zealand)
Fax: (64-4) 802-6881

This information is subject to change without notice.

Printed on recycled paper

© Agilent Technologies, Inc. 2006

Printed in USA September 26, 2006

5989-5699EN

