

EM Insights Series

Episode #3: Wireless Network Card Antenna Design

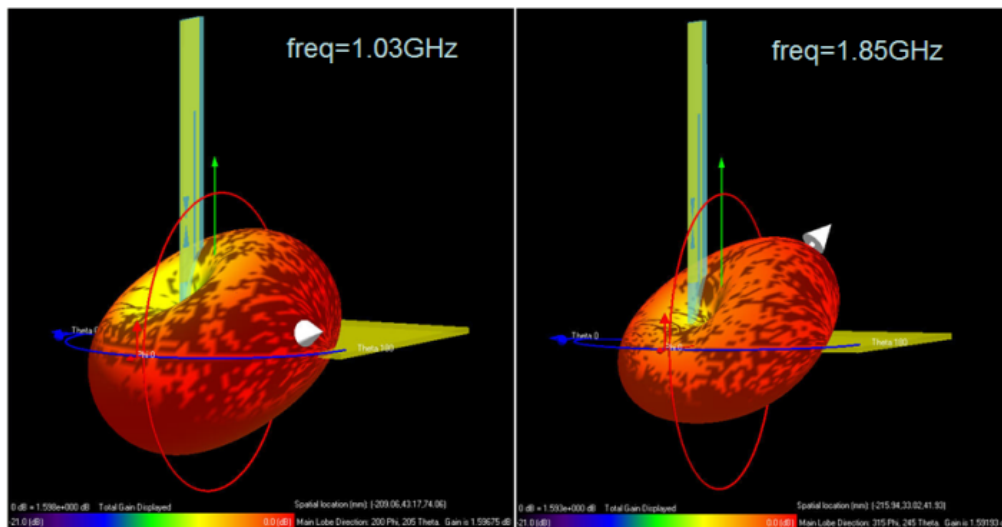

Agilent EEsof EDA
September 2008

Application Overview

Typical situation

Although there are many EM simulation technologies and tools available in the market place that antenna designers can use, it is still a hard question to answer which one is the best for a particular application. In the case of wireless network card antennas, there are only a few design examples that users can reference.

Potential users and targeted market

- Wireless network card manufacturers
- Antenna designers

EM product used

- [Electromagnetic Professional \(EMPro\)](#)

<http://www.agilent.com/find/eesof-empro>

Design Challenge

Design challenge

Wireless network card antenna designers are oftentimes challenged to reduce the size but it's a difficult design task without the aid of EM field solvers or visualizing current/field patterns on the antenna.

Problem solved

With EMPro, the design of a wireless network card antenna is simple and quick. The ultra fast simulation capability of EMPro enables designers to quickly test and verify various different configurations and sizes of antenna. EMPro's slick visualization feature enables designers to visualize the current and field pattern on the antenna surface, consequently it visually helps designers effectively design smaller antennas.

Value delivered

Designers can quickly design and test antennas for wireless network card application with EMPro's specialized antenna simulation capabilities.

Wireless Network Card Antenna

Many PCs and laptops use external wireless network card for networking. Since the antenna performance is critical to the overall system performance, the antenna must be properly designed.



Antenna Dimension

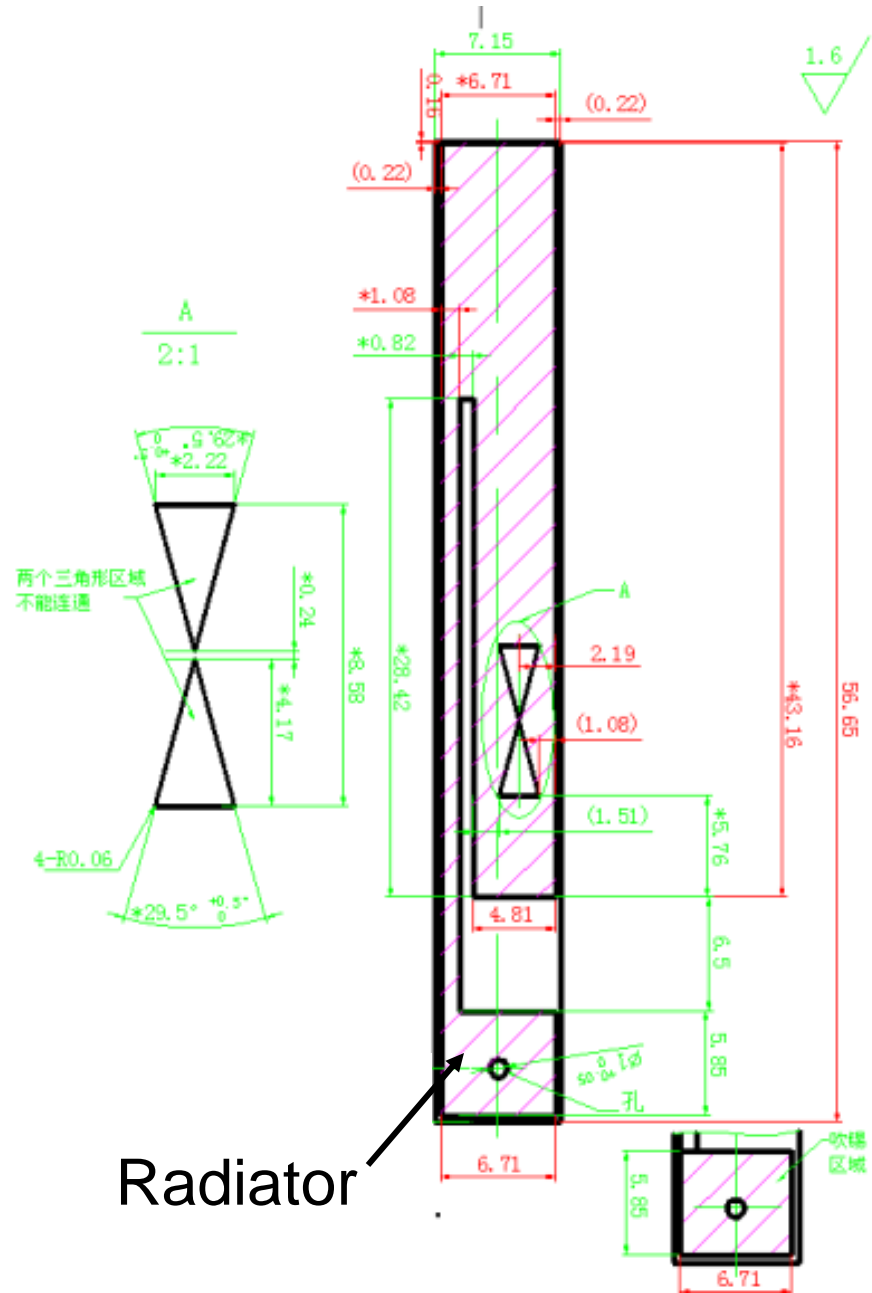

Radiator

Network Card's Ground Plane on PCB

The size of the ground plane affects the resonance frequency of antenna, so antenna designers must analyze the antenna with ground planes attached

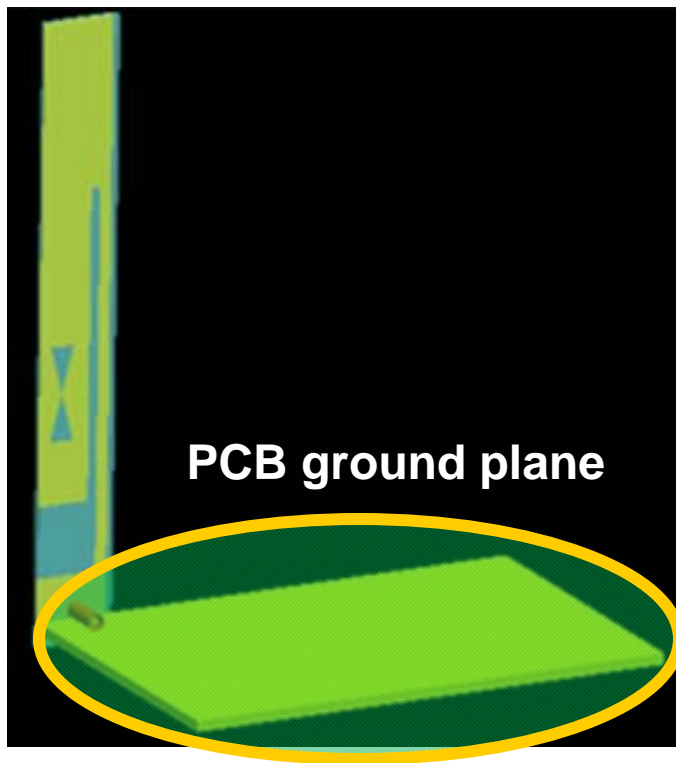

Changing the ground plane from 45 x 30 mm to 30 x 25 mm results higher resonant frequency

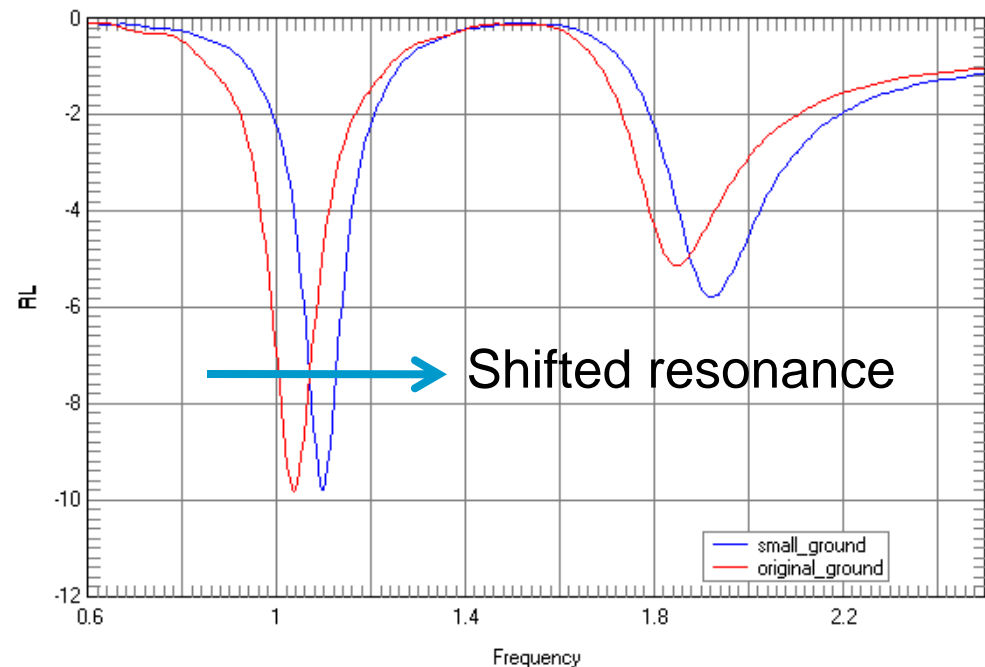

Antenna With and Without Localizer

The EMPro simulation demonstrates that the presence of localizer doesn't change the antenna's resonance frequency and the current distribution much.

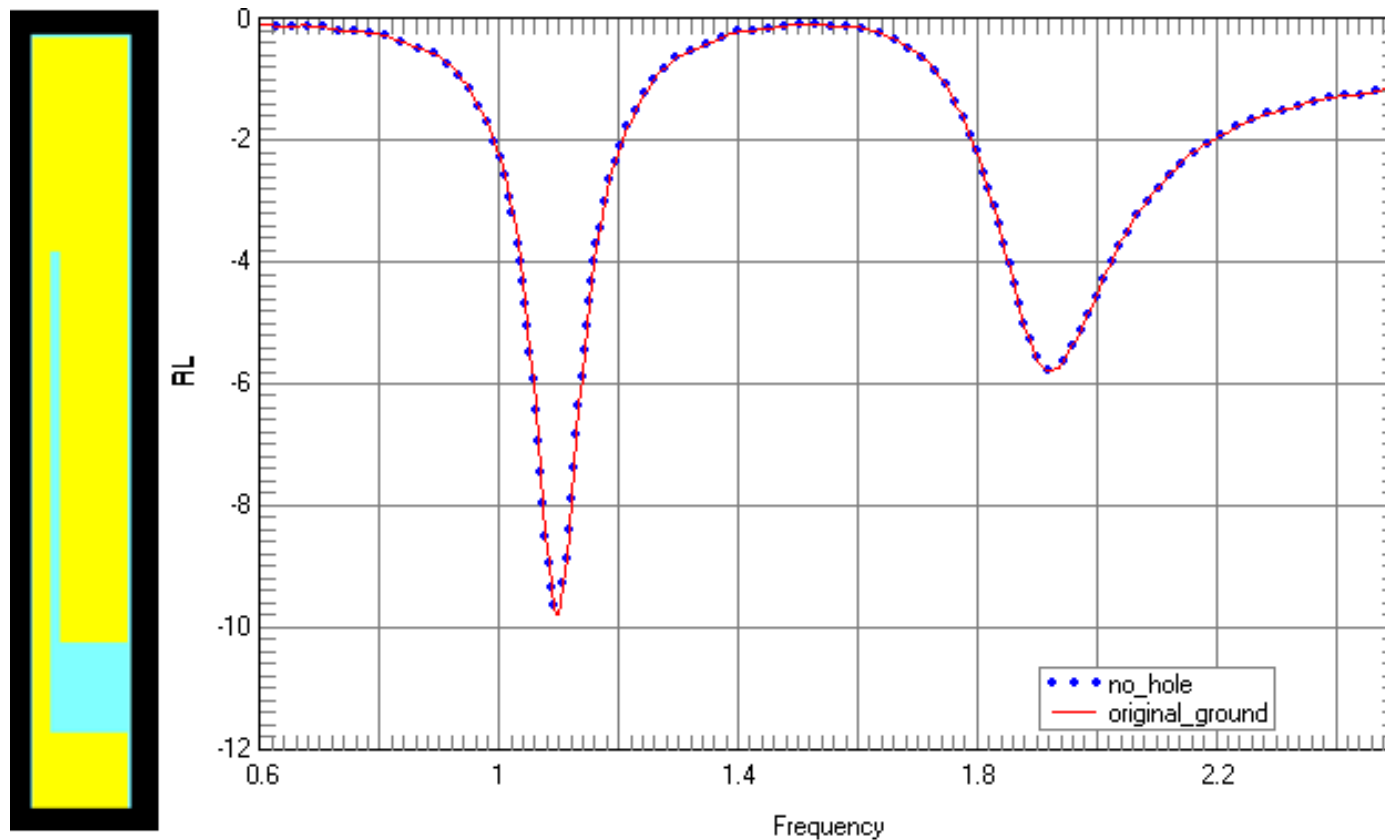

Far-field Pattern

At both frequencies, the antenna has good far-field patterns

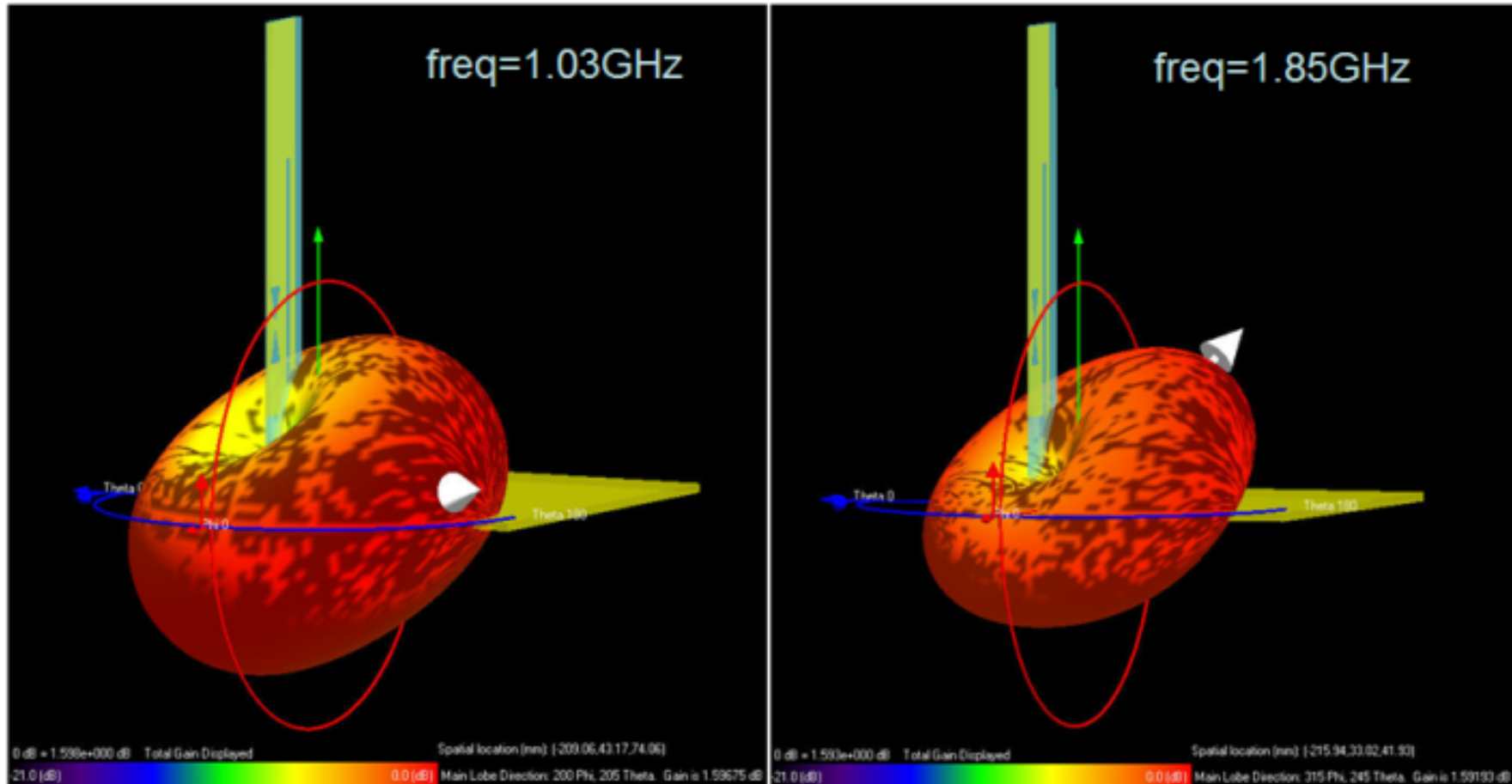

Current and E-field Plots

E-field pattern

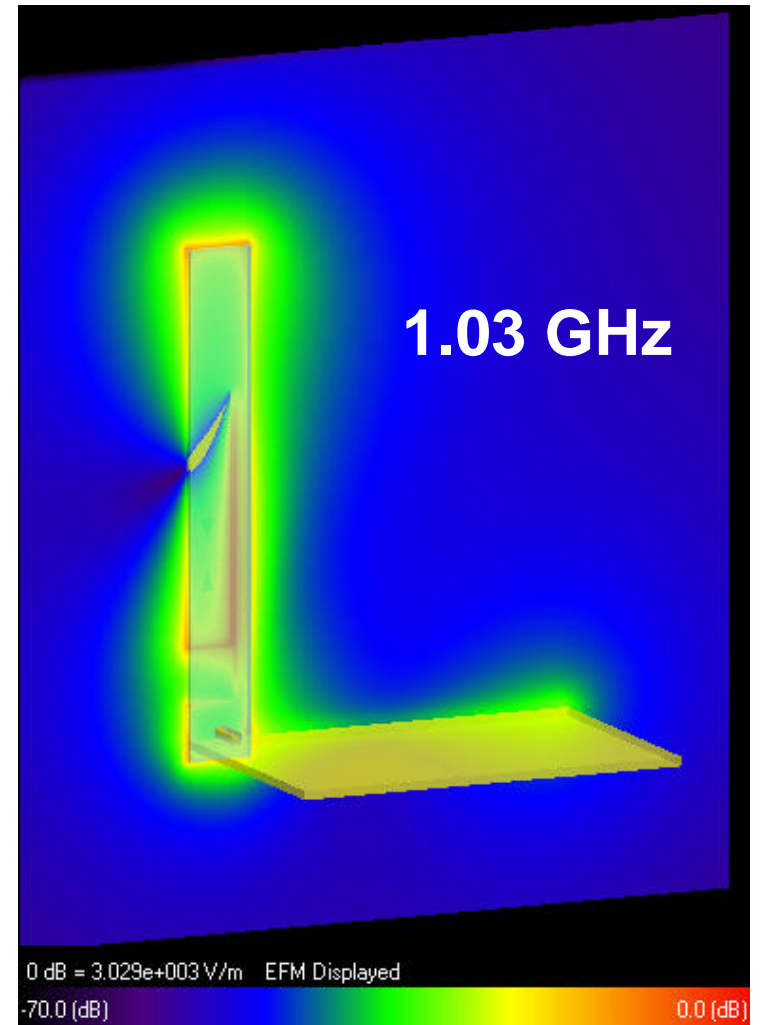
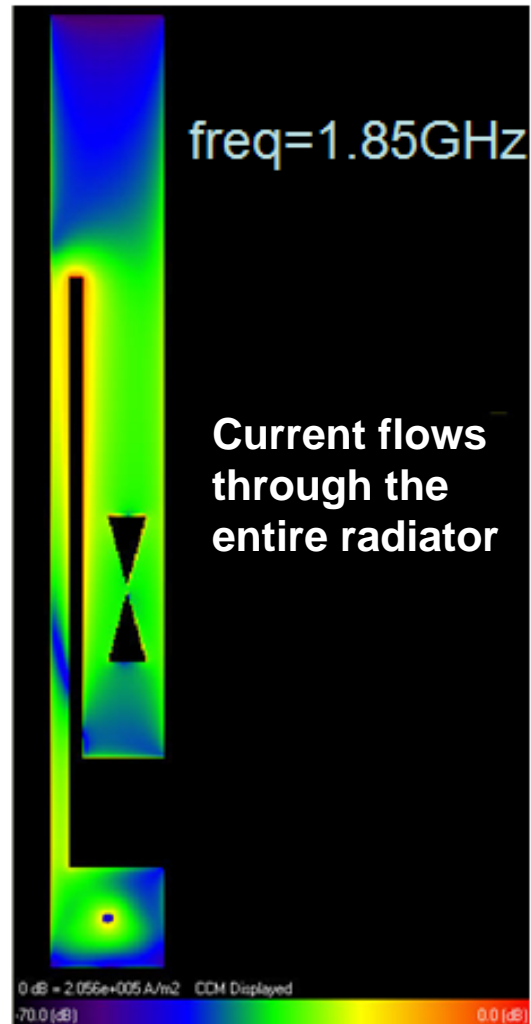
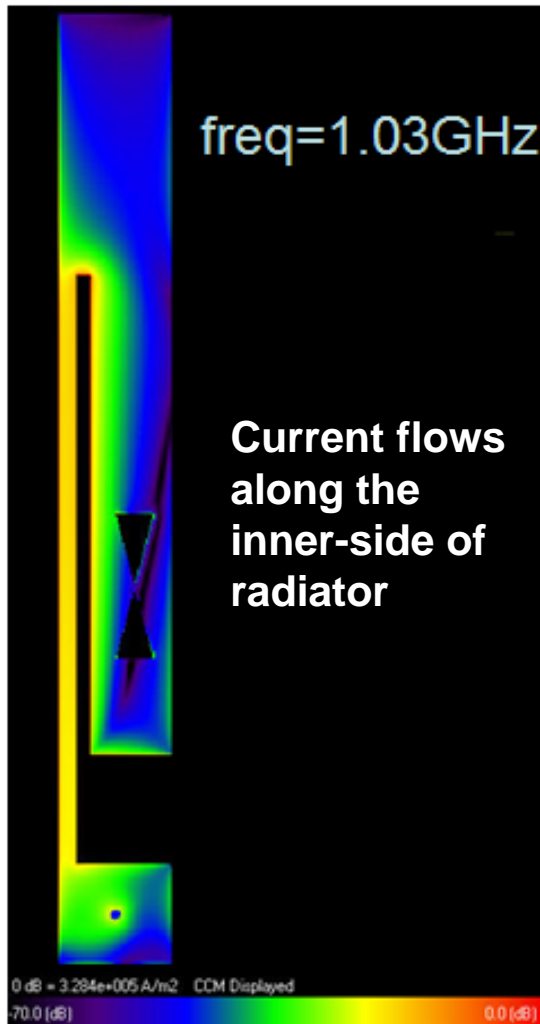

Smaller Antenna?

The antenna size may be made smaller by cutting the top side of antenna off where the current flow is less.

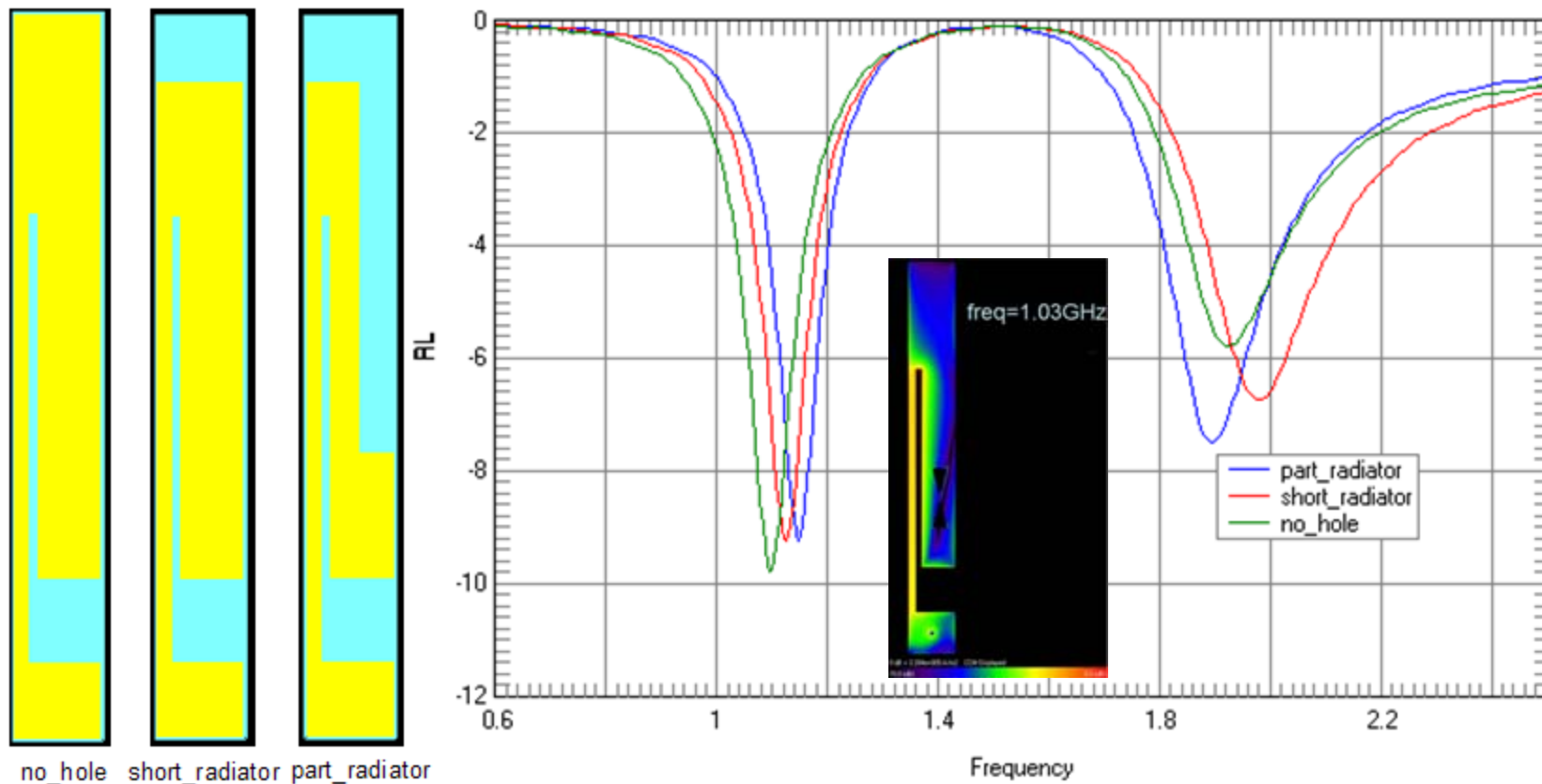

Measured vs. Simulated Comparison

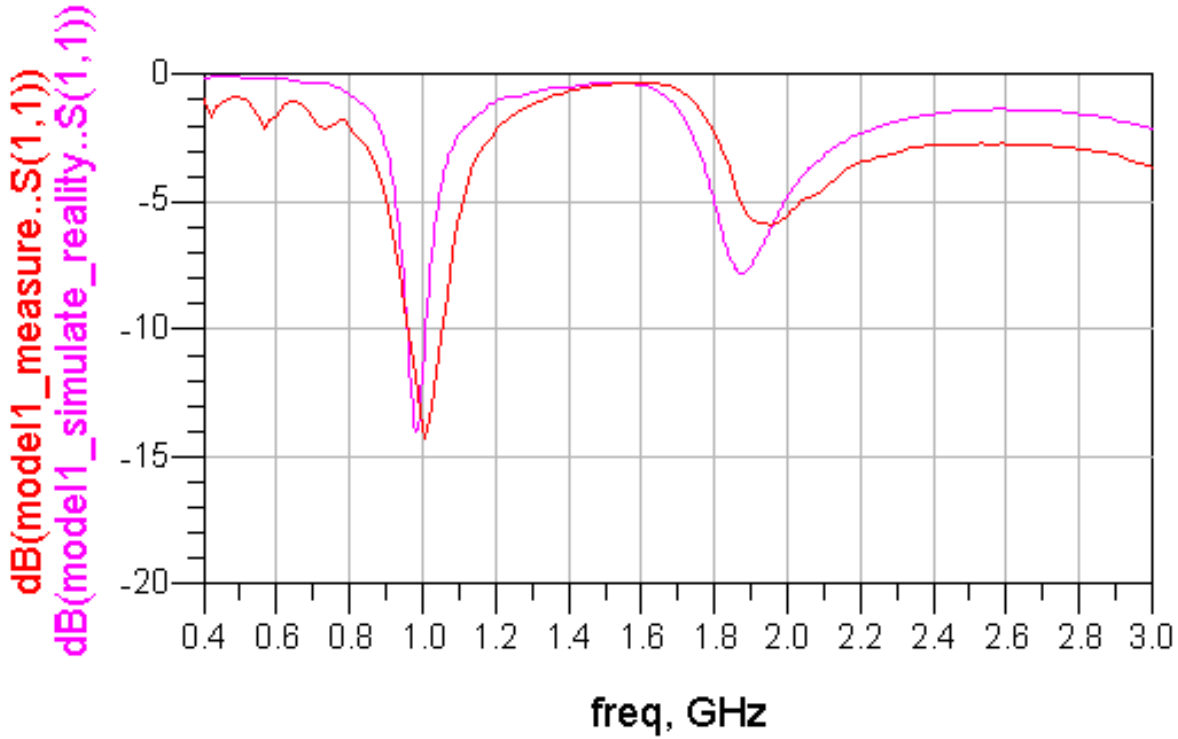

red = measured, pink = simulated

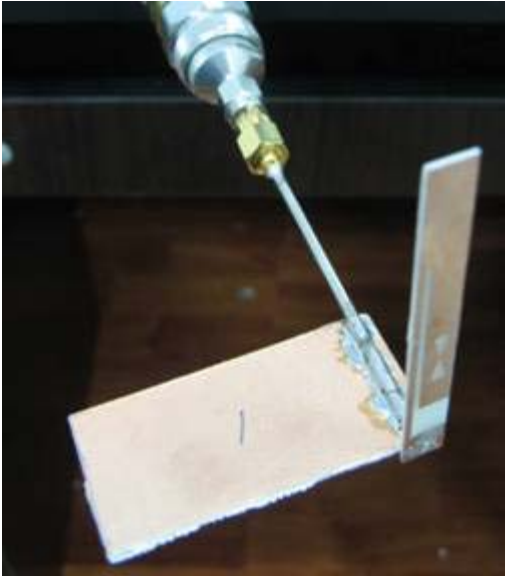

Measurement setup

Episode #3 Summary

- With EMPro, the design of wireless network card antenna is simple and quick. The ultra fast simulation capability of EMPro enables you to quickly test and verify different configurations and sizes of antenna.
- EMPro's visualization feature enables designers to visualize the current and field pattern on the antenna surface, consequently it visually helps designers effectively design smaller antennas.

Interested in learning more about this application?

- Request an [evaluation copy of EMPro](http://www.agilent.com/find/eesof-empro-evaluation)
<http://www.agilent.com/find/eesof-empro-evaluation>
- Request a [demo of EMPro](http://www.agilent.com/find/eesof-empro-demo)
<http://www.agilent.com/find/eesof-empro-demo>

For more information about
Agilent EEs of EDA, visit:

www.agilent.com/find/eesof

For more information on Agilent Technologies' products, applications or services, please contact your local Agilent office. The complete list is available at:

www.agilent.com/find/contactus

Contact Agilent at:

Americas

Canada (877) 894-4414
Latin America 305 269 7500
United States (800) 829-4444

Asia Pacific

Australia 1 800 629 485
China 800 810 0189
Hong Kong 800 938 693
India 1 800 112 929
Japan 0120 (421) 345
Korea 080 769 0800
Malaysia 1 800 888 848
Singapore 1 800 375 8100
Taiwan 0800 047 866
Thailand 1 800 226 008

Europe & Middle East

Austria 01 36027 71571
Belgium 32 (0) 2 404 93 40
Denmark 45 70 13 1515
Finland 358 (0) 10 855 2100
France 0825 010 700*
*0.125 €/minute
Germany 07031 464 6333
Ireland 1890 924 204
Israel 972-3-9288-504/544
Italy 39 02 92 60 8484
Netherlands 31 (0) 20 547 2111
Spain 34 (91) 631 3300
Sweden 0200-88 22 55
Switzerland 0800 80 53 53
United Kingdom 44 (0) 118 9276201
Other European Countries:
www.agilent.com/find/contactus

Product specifications and descriptions in this document subject to change without notice.

© Agilent Technologies, Inc. 2009
Printed in USA, March 30, 2009
5989-9983EN