

# Installation Note

---

**Agilent E8257D/67D and E8663D PSG Signal Generators  
Add Option UNY (Enhanced Ultra-Low Phase Noise)  
Kit Part Numbers: E8251-60690 and E8251-60990**

---

**NOTE** For the latest revision of this installation note, go to the following website:

*<http://www.agilent.com/find/psg> or  
<http://www.agilent.com/find/e8663d>*

---



Part Number E8251-90396  
Printed in USA April 2012



E8251- 90396

**Notice**

The information contained in this document is subject to change without notice.

Agilent Technologies makes no warranty of any kind with regard to this material, including but not limited to, the implied warranties of merchantability and fitness for a particular purpose. Agilent Technologies shall not be liable for errors contained herein or for incidental or consequential damages in connection with the furnishing, performance, or use of this material.

---

## Add Option UNY (Enhanced Ultra-Low Phase Noise)

### Kit Part Numbers: E8251-60690

Product Affected: .....	E8257D/67D and E8663D
Serial Numbers: .....	≥MY/SG/US5042xxxx
Options: .....	
To Be Performed By: .....	(X) Agilent Technologies Service Center
Estimated Installation Time: .....	2.0 hours
Estimated Verification Time: .....	2.0 hours

### Introduction

This upgrade kit adds Option UNY (Enhanced Ultra-Low Phase Noise Performance) to an E8257D, E8663D (Analog) or E8267D (Vector) PSG Signal Generator. This kit applies to instruments that have either a standard crystal oscillator or Option UNX.

Installation includes the following major steps, starting on [page 5](#):

1. Check signal generator functionality.
2. Check firmware version and upgrade if <C.06.15.
3. Remove the outer and inner signal generator covers.
4. Remove the A32 10 MHz Crystal Oscillator.
5. Install the A32 10 MHz Crystal Oscillator.
6. Remove and replace A5 with A46 and A6 with A45.
7. Install A43 board and cables.<sup>1</sup>
8. Activate Option UNY.
9. Verify proper installation of Option UNY.
10. Re-assemble the signal generator.
11. Verify signal generator calibration.

---

1. For instruments with serial prefixes ≥US5150/MY5150.

## Installation Kit Parts List

### E8251-60690

Item	Quantity	Description	Part Number
1	1	W155 Cable A33/A33 75G	8121-0646
2	1	Assembly, Frac-N, Used with Offset Loop	E8251-60437
3	1	Assembly, Offset Loop	E8251-60438
4	1	Oscillator Assy - UNY	E8251-60798
5	1	Installation Note	E8251-90396

### E8251-60990

(For E8257D and E8663D with serial prefix  $\geq$  US5150/MY5150)

Item	Quantity	Description	Part Number
1	1	Cable A33/A33 75G	8121-0646
2	1	Assembly, Frac-N, Used with Offset Loop	E8251-60437
3	1	Assembly, Offset Loop	E8251-60438
4	1	Oscillator Assy - UNY	E8251-60798
5	1	Cable Retainer	E8251-40001
6	1	Retainer - Cable Top	E8251-40007
7	1	Cable, LB Output to Amp Filter Board, 2 piece, Bottom	E8251-20488
8	1	Cable, LB Output to Amp Filter Board, 2 piece, Top	E8251-20489
9	1	A43, Assy, Amp Filter BD	E8251-60633
10	1	Installation Note, UNY Upgrade Kit	E8251-90396
11	1	Entitlement Certificate	n/a

### Tools Required

- TORX T-10 driver
- TORX T-15 driver
- TORX T-20 driver
- Needle-nose pliers

## Safety Considerations

---

**WARNING**            **Before you disassemble the signal generator, turn the power switch off and unplug the power cord. Failure to unplug the signal generator can result in personal injury.**

---

**CAUTION**            Electrostatic discharge (ESD) can damage or destroy electronic components. All work on electronic assemblies should be performed at a static-safe workstation.

---

### Check Signal Generator Functionality

Use the following procedure to confirm that the signal generator powers up and the internal check identifies no errors. The internal check evaluates the operation of the signal generator and returns an error message if it detects a problem.

---

**NOTE**            When the signal generator is first connected to ac line power, the error message ERROR 514, Reference Oven Cold occurs, which causes both the OVEN COLD annunciator and the ERR annunciator to turn on.

After approximately five minutes, the OVEN COLD annunciator automatically clears, but the ERR annunciator remains on until all errors are cleared from the error queue.

---

1. Turn on the signal generator and let it warm up for at least five minutes.
2. Run the signal generator self-test by pressing **Utility > Instrument Info/Help Mode > Self Test > Run Complete Self Test**. Upon completion, a summary of the self-test will be displayed. Use the E8257D/67D, E8663D PSG Service Guide, E8251-90359, to troubleshoot any failures detected by the test.

---

**NOTE**            Some circuits may require up to 50 minutes to warm up before passing the self-test. If self-tests continue to fail after 50 minutes of warm up, troubleshoot the instrument.

---

3. Check to see if the ERR annunciator is on.
  - If the ERR annunciator is on, review the error messages in the error queue by pressing **Utility > Error Info**. The first page of error messages in the error queue appears in the display text area. (Refer to the signal generator error messages document for information about each error message.)

After resolving all problems causing errors, press **Clear Error Queue(s)**.
  - If the ERR annunciator is off, the signal generator functionality check has passed.

### Check Firmware Version and Upgrade if <C.06.15

1. Press **Utility > Instrument Info/Help Mode > Diagnostic Info**.
2. Find the firmware information.
3. If the version of firmware is <C.06.15, upgrade the firmware.

## **Remove the Outer and Inner Signal Generator Covers**

### **Remove the Outer Cover**

Refer to [Figure 1](#).

1. Disconnect the power cord.
2. Using a T-20 driver, loosen the two screws (1) and remove the strap handle (2).
3. Using a T-15 driver, remove the center screws (3) on the four rear-panel feet (4).
4. Remove the four bottom feet (5) from the cover by lifting the tab and sliding the foot toward the tab.
5. Place the signal generator on its side.
6. Tilt the signal generator forward and slide the outer cover (6) back to remove it from the frame.

### **Remove the Inner Top Cover**

Refer to [Figure 2](#).

1. Using a T-10 driver, remove the screws (1) from the inner-top cover (2). There are twelve screws for E8257D/E8663D and eleven screws for E8267D.
2. Remove the inner-top cover.

Figure 1

Outer Cover Removal

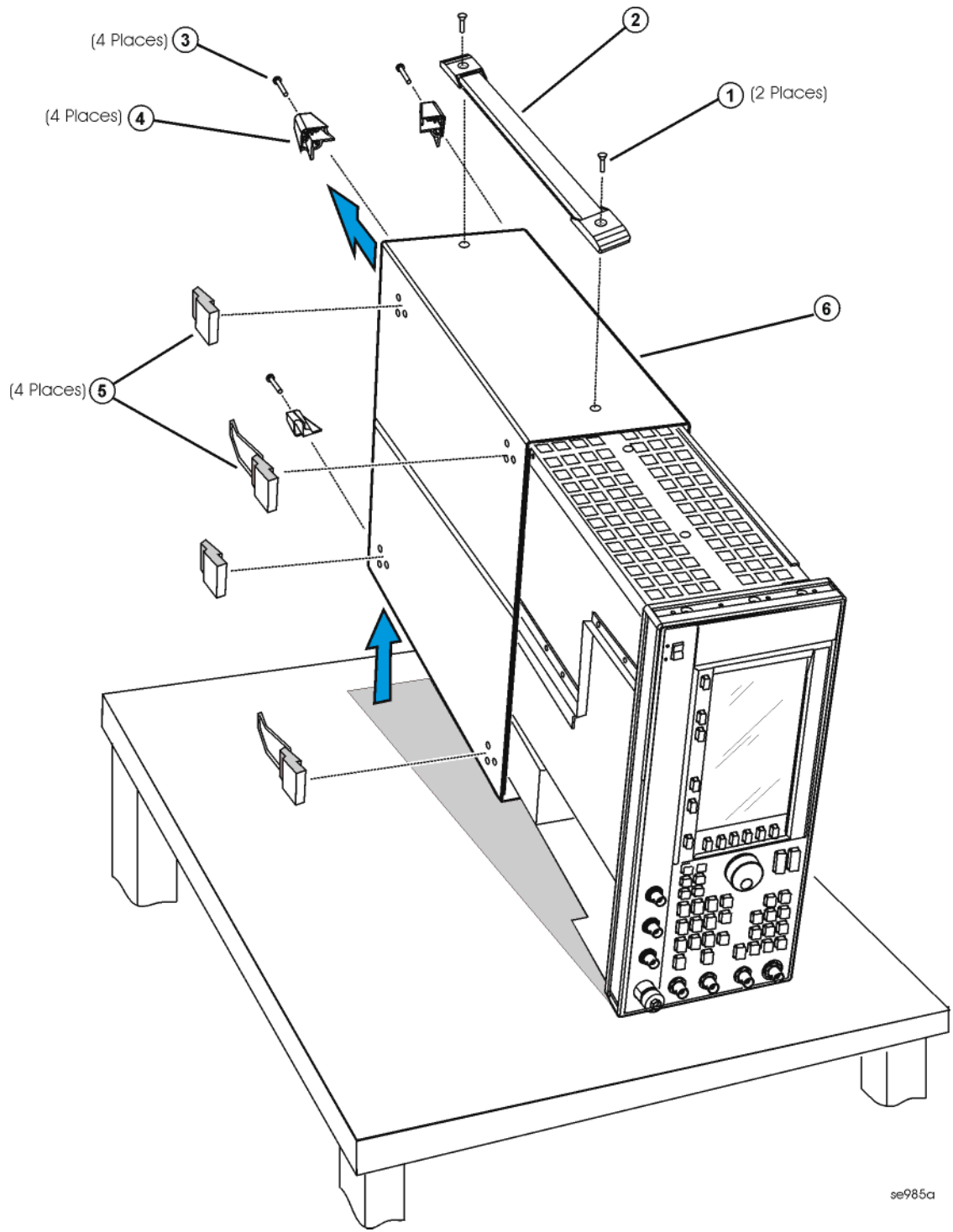

se985a

Figure 2

Inner Top Cover Removal

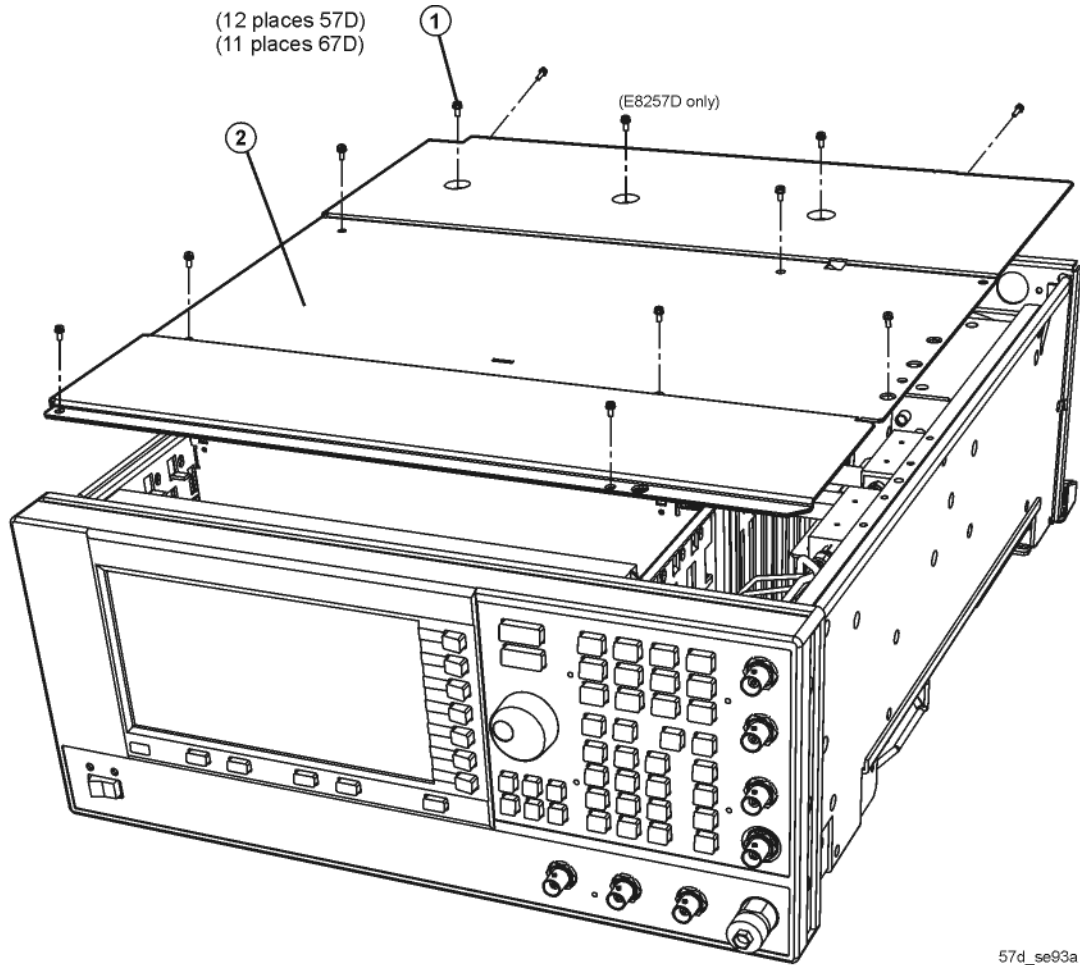

57d\_se93a

## Remove the A32 10 MHz Crystal Oscillator

Refer to [Figure 3](#) for this procedure.

1. Position the signal generator with the rear panel facing you.
2. Using the needle-nose pliers, disconnect the W47 flexible cable (A31 Motherboard J1041) from A32J2.
3. Using the needle-nose pliers, disconnect the W48 flexible cable (10 MHz EFC) from A32J1.
4. Disconnect the A32W1 bias cable from the A21 Rear Panel Interface P2.
5. Using the T-10 driver, remove the three screws (3) that attach the A32 10 MHz Crystal Oscillator to the rear panel.
6. Remove the A32 10 MHz Crystal Oscillator.

## Install the A32 10 MHz Crystal Oscillator

---

**NOTE** W47 may be shipped disconnected from the A32 10 MHz Crystal Oscillator. If it is disconnected, connect one end of the cable to A32J2 before you start the installation procedure.

---

Refer to [Figure 3](#).

1. Position the signal generator with the rear panel facing you.
2. Using a T-10 driver, install the three screws (3) to secure the A32 10 MHz Crystal Oscillator to the rear panel.
3. Connect the A32W1 bias cable to the A21 Rear Panel Interface Board, A21P2.
4. Using the needle-nose pliers, connect the W48 flexible cable from 10 MHz EFC (rear panel connector) to A32J1.
5. Using the needle-nose pliers, connect the W47 flexible cable to J1041 of the A31 Motherboard.

Figure 3

A32 10 MHz Crystal Oscillator

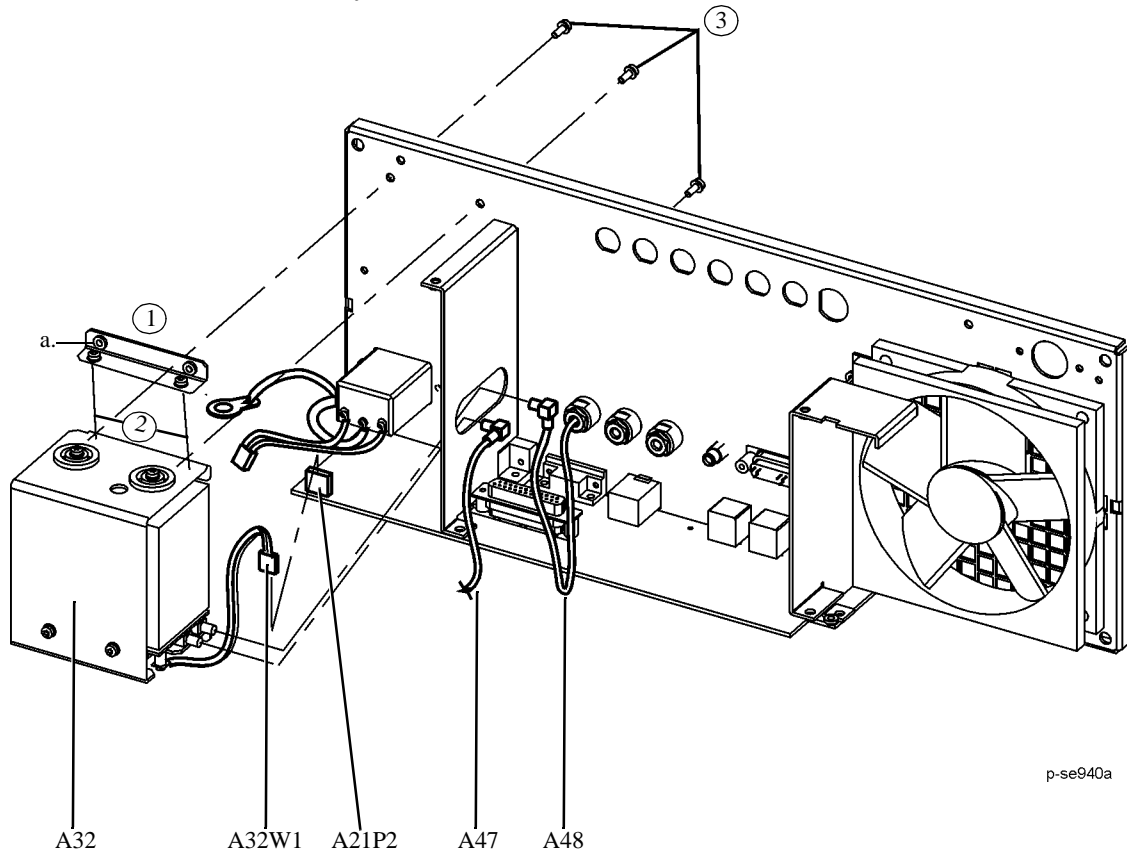

a.Used only on E8267D with serial prefix <US4824/MY4824 and all E8257D.

## Remove and replace A5 with A46 and A6 with A45

Refer to [Figure 4](#).

1. Position the signal generator with the front panel facing you.
2. Lift the retention levers and disconnect the A5 Sampler, A6 Frac-N boards from the A31 Motherboard.
3. Lift the boards out of the slots.
4. Position the signal generator with the front panel facing you.
5. Install the A46 (Offset Loop) to the A5 slot and A45 (Frac-N) to the A6 slot

**Figure 4** A5 Sampler, A-6 Frac-N, A45 Frac-N, and A46 Offset

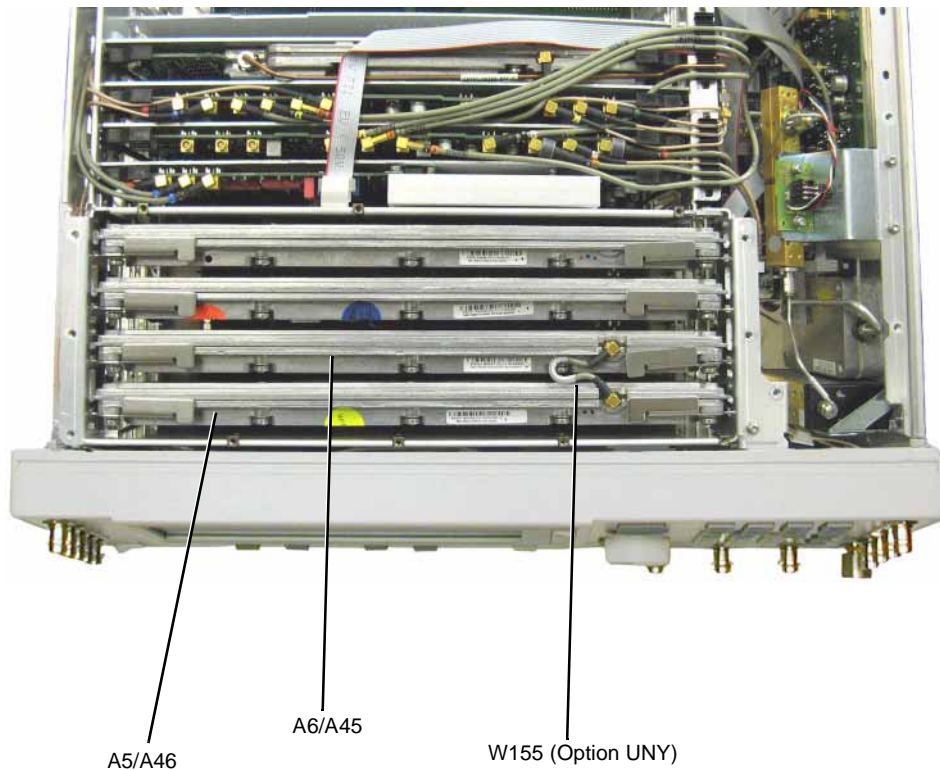

## Install new A43 board and cables (For E8257D/57N and E8663D with Serial Prefixes >= US5150/MY5150)

Refer to [Figure 5](#).

1. Position the signal generator with the front panel facing you.
2. Disconnect W139 and remove A43.
3. Replace A43 with the new part, E8251-60633 and reconnect W139.
4. Remove A8 board to install cables.
5. Use cable retainer within the kit to Install W138, E8251-20488. Refer to figure 10.
6. Install W140, E8251-20489. Refer to figure 6.

7. Connect remaining end of W138 to remaining end of W140.
8. Re-install A8 board.

**Figure 5**

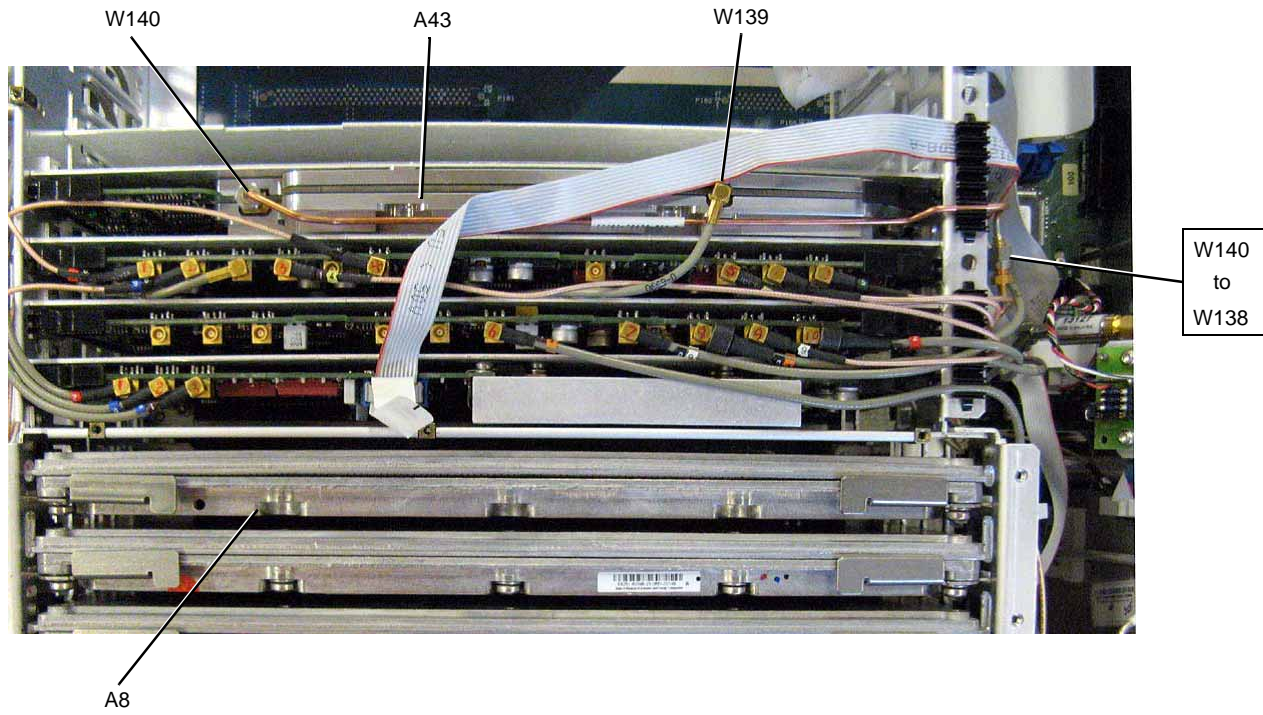

**Figure 6**

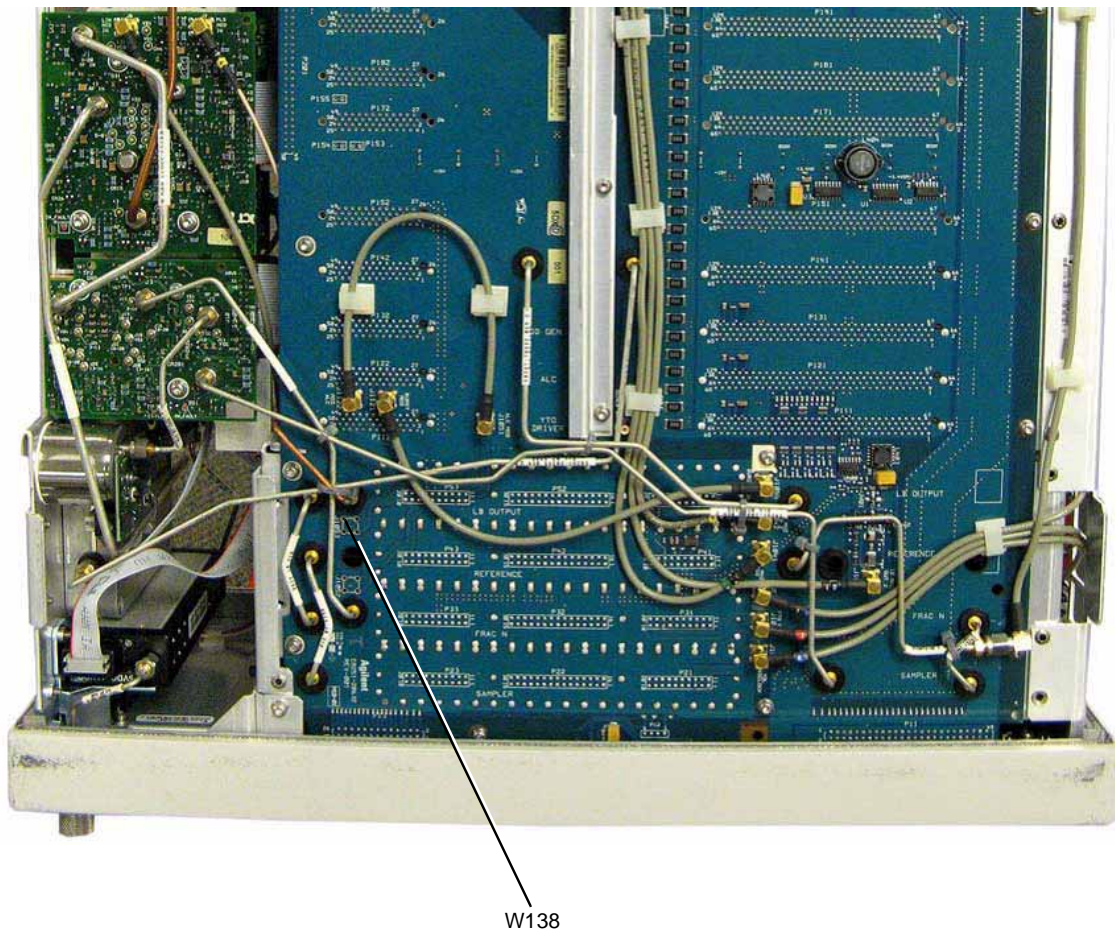

### **Activate Option UNY**

1. Follow the instructions on the Entitlement Certificate.

### **Verify Proper Installation of Option UNY**

1. Turn the instrument on and allow it to warm up for 5 minutes.
2. Press: **Utility > Instrument Info/Help Info > Options Info**.
3. Make sure Option UNY is listed.
4. Press **Utility > Instrument Adjustments > Reference Oscillator Adjustment > Restore Factory Defaults**.
5. Make sure Internal Ref Bandwidth (125 Hz) and External Ref Bandwidth (650 Hz) are listed.

---

**NOTE** If you enable an option that does not have the required hardware installed, the menus for that option will be activated but the option *cannot* operate.

---

## Re-Assemble the Signal Generator

Refer to [Figure 1](#) and [Figure 2](#).

1. Turn the signal generator off and unplug it.
2. Reinstall the inner and outer instrument covers by reversing the order for removal.
3. Torque all T-10 screws to 9 in-lbs.
4. Torque all T-15 and T-20 screws to 21 in-lbs.

## Verify Signal Generator Calibration

1. Turn the signal generator on and allow it to warm up for 30 minutes.
2. Perform the following adjustment/performance tests to verify signal generator calibration. Refer to the PSG Family Signal Generators Calibration Software:

---

**NOTE** It is normal to see an “unlock” indicator prior to performing an adjustment.

---

### Adjustment Tests

- a. ADC Calibration
- b. Frac-N Pretune Calibration
- c. Offset Loop Pretune Calibration
- d. Yig-Driver Pretune Calibration
- e. KV vs. Frequency Calibration
- f. FM Scale Offset Calibration
- g. FM Path Offset Calibration
- h. FM In-Band DCFM Calibration
- i. FM Out-of-Band YO Calibration

### Performance Tests:

- a. Self Tests
- b. Harmonic Spurious
- c. Sub-Harmonic Spurious
- d. Non-Harmonic Spurious
- e. Single-Sidedband Phase Noise