

User's Guide

Publication number N2772-92002
September 2002

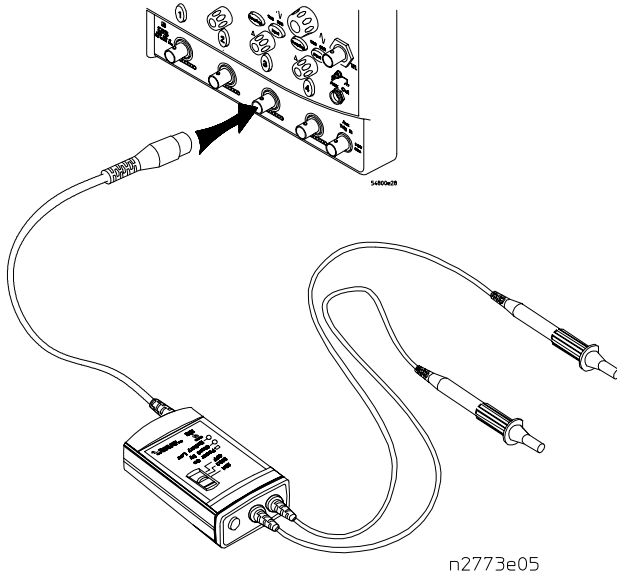

For Safety, Regulatory, and publishing information, see the pages at the back of this book.

© Copyright Agilent Technologies 1999-2002
All Rights Reserved.

N2772A Differential Voltage Probe

Contents

Inspect the Probe	3
Compatibility	4
Probe Parts Supplied	5
Characteristics and Specifications	6
Electrical Characteristics	6
Input Characteristics	7
Output Characteristics	7
Environmental Specifications	7
Safety Specifications	8
Using the N2772A Probe	10
Powering the N2772A	10
External Power Supply	10
Install or Replace the Battery	11
Oscilloscope Input Characteristic	11
Select the Correct Attenuation	12
Measurement Tips	12
Calibration Testing Procedures	14
Cleaning the Probe	18

Inspect the Probe

Inspect the shipping container for damage.

Keep a damaged shipping container or cushioning material until the contents of the shipment have been checked for completeness and the probe has been checked mechanically and electrically.

Check the accessories.

Any accessories that were supplied with the probe are listed in “Probe Parts Supplied” this manual.

- If the contents are incomplete or damaged, notify your Agilent Technologies Sales Office.

Inspect the instrument.

- If there is mechanical damage or defect, or if the probe does not operate properly or pass calibration tests, notify your Agilent Technologies Sales Office.
- If the shipping container is damaged, or the cushioning materials show signs of stress, notify the carrier as well as your Agilent Technologies Sales Office. Keep the shipping materials for the carrier’s inspection. The Agilent Technologies office will arrange for repair or replacement at Agilent Technologies’ option without waiting for claim settlement.

N2772A Differential Voltage Probes

The N2772A differential probe allows you to safely measure floating circuits, as high as 600V dc peak to ground, with the oscilloscope grounded. It is ideal for many applications such as motor speed controls, power supply designs and electronic high-power converters.

With 20 MHz bandwidth, switchable attenuation of 20:1 and 200:1, and a maximum voltage input of 600V, it provides the versatility for a broad range of applications including high-voltage circuits.

Each probe comes with sharp probe tips for use on small components and in tight places and alligator clips for connecting to larger cables.

The probe is powered by a 9V battery or by using a separate power supply, the N2773A.

Compatibility

The N2772A differential probe is compatible with any oscilloscope that has the following features:

- 1 M Ω input impedance
- Can display 30V peak input
- Has BNC input

Probe Parts Supplied

The following diagram and table show the parts supplied with the N2772A Probe.

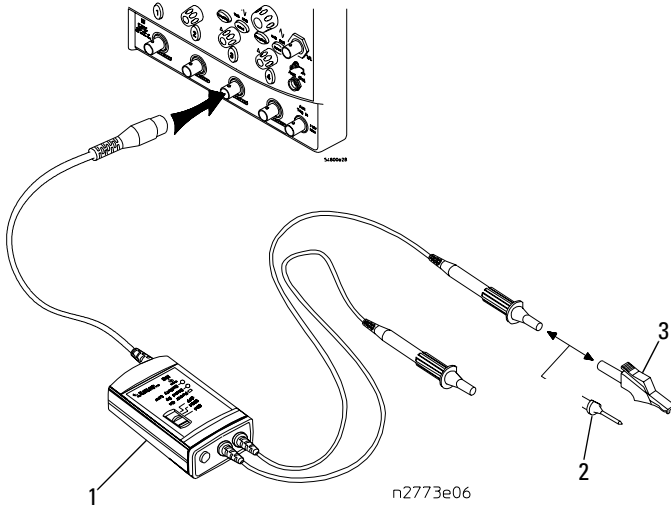

Parts for N2772A Probe

Item	Description	Part Number
1	Differential voltage probe	N2772-60001
2	Probe tips	5063-2188
3	Banana jack alligator - black	5063-2189
4	Banana jack alligator - red	5063-2187
5	Hook Retractable - black	5063-2191
6	Hook Retractable - red	5063-2190

Characteristics and Specifications

Characteristics and specifications for the N2772A Differential Voltage Probe are shown below.

Electrical Characteristics

Attenuation ratios	20:1 and 200:1 (Selectable via switch on probe.)
Bandwidth (into 1 M Ω , 50 pF)	20 MHz
Accuracy	$\pm 2.5\%$ into 1 M Ω
Rise Time	200x: 17.5 ns 20x: 17.5 ns
High CMRR	80 dB @ 60Hz, 50 dB @ 1 MHz
Input impedance	Between inputs: 10 M Ω , 5 pF
Output impedance	50 Ω
Noise	200x: <2 mVrms 20x: <3 mVrms
Offset	≤ 10 mV into 1 M Ω
Switch positions	OFF, 200x, 20x
External power	Via power adapter N2773A (optional)
Internal power	Battery power: Alkaline 9V, IEC6LR61 Battery life: 8 hour operation, 400 hour in auto standby*
Power indicators	Green LED: ON at normal operation. Blinks at standby. Red LED: ON when battery needs to be replaced.
Auto stand by	After 30 minutes, only when battery operated.

*Battery life measured @ 25 ° C with Duracell® alkaline battery. (Delivered with probe.)

For derating of each input probe (red or black), see the figure below.

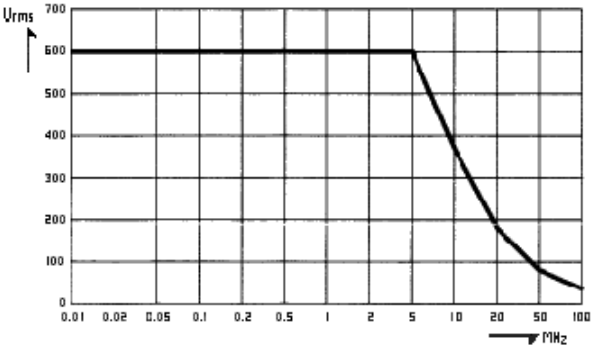

Input Characteristics

Input probe tip style	Shrouded banana probe tip
Probe cable length	1.5 meter (60 inches)
Maximum input voltage to ground	600V CAT III 1000V CAT II
Maximum differential input voltage	1000 VDC, or 1000 Vrms, or 1200V (DC + AC peak)

Output Characteristics

Output Characteristics

Output cable	Safety designed BNC cable
Cable length	0.5 meter (20 inches)
Maximum output voltage range	± 6.5 V into 1 M Ω

Environmental Specifications

Temperature	Operating: 0 °C to +50 °C (+32 °F to +122 °F) Storage: -10 °C to +60 °C (+14 °F to +140 °F)
Altitude	Operating: 3 km (9850 feet) Storage: 12km (40,000 feet)

N2772A Differential Voltage Probe
Characteristics and Specifications

Table 1

		Susceptibility (in % of full dynamic range)
Frequency range:	E = 3 V/m	E = 10 V/m
10 kHz to 25 MHz		
20x	<1%	<1%
200x	<1%	<1%
Frequency range:	E = 3 V/m	E = 10 V/m
25 MHz to 1 GHz		
20x	<=1%	<=2%
200x	<=1%	<=2%

Safety Specifications

Meets requirements of:	EN61010-2-31 (IEC1010-2-31)
Compliant with:	UL3111-1 (including listing) CSA C22.2 No. 1010.1-92 (approval: pending)
Max floating output voltage	600V Category III, up to 400Hz. (From shielding to ground.)

WARNING SHOCK HAZARD!



These probes are designed for use with oscilloscopes that have a common terminal at *GROUND POTENTIAL* (in accordance with OSHA requirements and the National Electric Code). Exposed metallic surfaces of the probe and the oscilloscope *MUST BE GROUNDED*. Failure to ground the common terminal during certain applications, such as those requiring the oscilloscope to be powered from an external battery, might expose the operator to an electrical shock hazard that could be lethal (depending on voltage and current conditions.)

WARNING Do the following to avoid electrical shock or fire if the probe is connected to more than 42V peak (30V rms):

- Use only the N2773A power adapter or a 9V battery.
- Connect the power adapter to the AC outlet before connecting it to the N2772A.
- Do not insert metal objects in the power adapter connector.
- Use 600V rated test lead adapters. The maximum allowable input voltage is 600V, Category III.



This symbol signifies that the N2772A Differential Probe is protected by double or reinforced insulation. Only use specified replacement parts when servicing the instrument.



This symbol signifies CAUTION! and requests that the user refer to the user manual before using the instrument.

Using the N2772A Probe

Powering the N2772A

The N2772 probe can be powered either by an internal 9V battery or the N2773A power supply. The battery has a limited life. For this reason the probe has a LOW BATTERY indicator and will automatically switch to STAND BY mode after approximately 30 minutes. If you store the probe for extended periods of time, remove the battery and store it separately.

External Power Supply

For convenience the N2773A power supply is recommended. When you use this power supply, take care to select the appropriate voltage with the switch on the rear of the probe power supply. The power source has been designed to provide the correct power with 50 Hz, 60 Hz and 400 Hz sources of 115V and 230V.

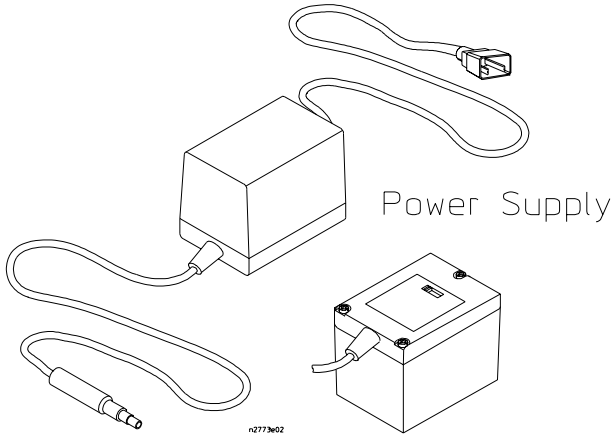

Install or Replace the Battery

WARNING



Never install or replace the battery while the probe is connected to a voltage source. Replace the battery when the red LED is lit, or when both red and green LED's are off when the probe is switched on.

The expected battery life is 8 hours of operation and 400 hours in auto standby.

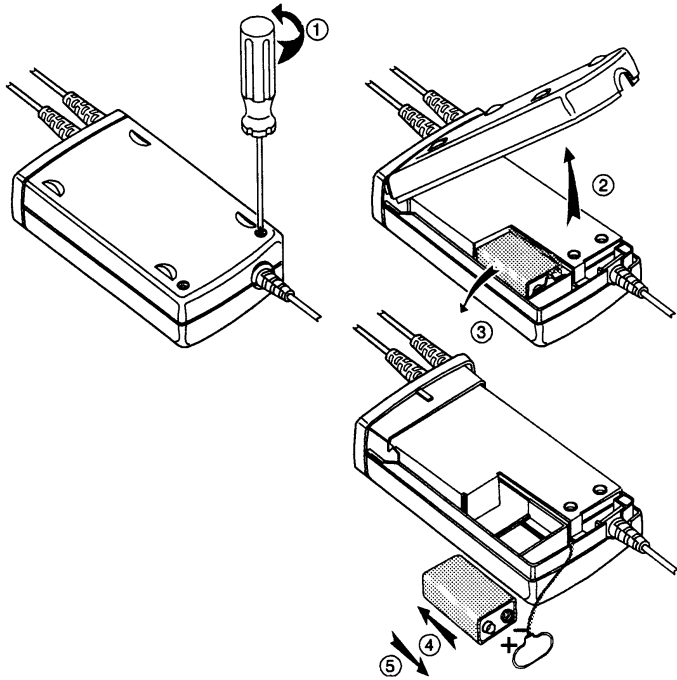

Oscilloscope Input Characteristic

The probe has been designed to drive a $1\text{M}\Omega$ input to maximize battery life. The input capacitance of the oscilloscope should be $< 50\text{ pF}$.

Select the Correct Attenuation on the Probe and the Oscilloscope

The probe has two modes of operation, 20:1 and 200:1 attenuation. Select the desired attenuation on the probe and the correct probe attenuation setting on the oscilloscope. This will ensure that accurate voltage readings can be made directly from the oscilloscope.

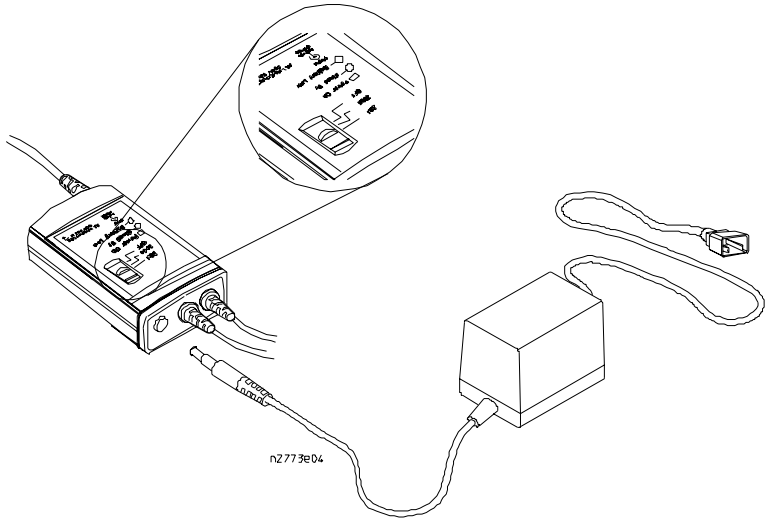

Measurement Tips

- Use the 20x range on the differential voltage probe for smaller signals, such as ripple on a high voltage reference lead.
- When the probe is battery operated, the red LED indicates that the battery level is low and the battery needs to be replaced.
- When battery operated, the probe automatically goes to standby mode after 30 minutes to conserve battery power. A blinking green LED indicates that the probe is in standby mode. To continue operation, turn the range selection switch from OFF to 20x or 200x.
- Connect the red probe cable to a more positive or more negative voltage level than the black probe cable.

Service Strategy

For repair, calibration, and to ensure the N2772A performs to its warranted specifications, send the probe to an Agilent Service Center for calibration testing procedures. The probe should be tested once a year or as required by other standards. If repair is needed and the N2772A is under warranty, normal warranty services will apply. If the N2772A is not under warranty, repair costs will be applied.

To return the Probe to Agilent Technologies for Service

Call (877) 477-7278 for further details and the location of your nearest Agilent Technologies Service Office.

- 1 Write the following information on a tag and attach it to the probe.**
 - Name and address of the owner
 - Probe model number
 - Description of service required or failure indication
- 2 Retain all accessories.**
- 3 Return the probe in its case or pack the probe in foam or other shock-absorbing material and place it in a strong shipping container. You can use the original shipping materials or order materials from an Agilent Technologies Sales Office. If neither are available, place 3 to 4 inches of shock-absorbing material around the instrument and place it in a box that does not allow movement during shipping.**
- 4 Seal the shipment container securely.**
- 5 Mark the shipping container as FRAGILE. In all correspondence, refer to the instrument by model number and full serial number.**

Calibration Testing Procedures

These procedures are used to test the warranted specifications for the N2772A Differential Probe. The recommended calibration test interval for the N2772A is once a year or as required. Use the equipment listed in the “Test Equipment Required” section to complete the Calibration Testing Procedures.

Required Test Equipment

Description	Minimum Requirements	Part Number
Multimeter	8.5 digits of resolution	3458A
Oscilloscope	100 MHz	54622A
Calibrator	DC Voltage 0 to ± 1100 V	Fluke 5700A
Programmable Function Generator	50 MHz sine wave	
N2772A probe with N2773A power supply		

Adaptation 1 - $50\ \Omega$ T-piece BNC + (2) $50\ \Omega$ right angle BNC + (2) BNC (m) to banana (f)

Adaptation 2 - $50\ \Omega$ termination + BNC (m) to banana (f)

Adapter - BNC (f) to banana (m)

Setup Files for testing

Setup for CMRR at 60 Hz at 20X Setting on Probe

CH1	ON
CH1 Sensitivity	5 mV/div, AC
CH2	OFF
CH2 Sensitivity	2 V/div, DC
Timebase	2 ms/div
BWL (Bandwidth Limiter)	ON
Trigger on	CH2

Setup for CMRR at 60 Hz at 200X Setting on Probe

CH1	ON
CH1 Sensitivity	2 mV/div, AC
CH2	OFF
CH2 Sensitivity	2 V/div, DC
Timebase	2 ms/div
BWL (Bandwidth Limiter)	ON
Trigger on	CH2

Setup for CMRR at 1 MHz at 20X Setting on Probe

CH1	ON
CH1 Sensitivity	200 mV/div, AC
CH2	OFF
CH2 Sensitivity	2 V/div, DC
Timebase	500 ns/div
BWL (Bandwidth Limiter)	ON
Trigger on	CH2

Setup for CMRR at 1 MHz at 200X Setting on Probe

CH1	ON
CH1 Sensitivity	50 mV/div, AC
CH2	OFF
CH2 Sensitivity	2 V/div, DC
Timebase	500 ns/div
BWL (Bandwidth Limiter)	ON
Trigger on	CH2

N2772A Differential Voltage Probe
Calibration Testing Procedures

Setup for Bandwidth at 20 MHz, 20X Setting on Probe

CH1	ON
CH1 Sensitivity	100 mV/div, AC
CH2	OFF
CH2 Sensitivity	2 V/div, DC
Timebase	20 ns/div
BWL (Bandwidth Limiter)	OFF
Trigger on	CH2

Setup for Bandwidth at 20 MHz, 200X Setting on Probe

CH1	ON
CH1 Sensitivity	10 mV/div, AC
CH2	OFF
CH2 Sensitivity	2 V/div, DC
Timebase	20 ns/div
BWL (Bandwidth Limiter)	OFF
Trigger on	CH2

Test Offset

- 1 Power the N2772A with the N2773A power supply.
- 2 Connect the N2772A output to the 3458A multimeter via the BNC (f) to banana (m) adapter.
- 3 Verify the value is between the 3458A limits listed in the table below for each probe setting.
- 4 Record the value displayed on the 3458A in the Calibration Test Record.

Test	Test Signal	N2772A Setting	3458A Reading Limits
Offset	None	20X	-10 mV ... +10 mV
Offset	None	200X	-10 mV ... +10 mV

Test Gain

- 1 Connect the red end of the N2772A probe to the calibrator HI output.
- 2 Connect the black end of the N2772A probe to the calibrator LO output.
- 3 Connect the N2772A probe output to the 3458A multimeter via the BNC (f) to banana (m) adapter.
- 4 Verify the value is between the 3458A limits listed in the table below for each output signal at each probe setting.
- 5 Record the value displayed on the 3458A in the Calibration Test Record.

Test	Calibrator Output Signal DC	N2772A Setting	3458A Reading Limits
Gain	+10 V	20X	+488 mV... +512 mV
Gain	+100 V	20X	+4.88 V... +5.12 V
Gain	+100 V	200X	+488 mV... +512 mV
Gain	+1000 V	200X	+4.88 mV... +5.12 V
Gain	-10 V	20X	-488 mV... -512 mV
Gain	-100 V	20X	-4.88 mV... -5.12 V
Gain	-100 V	200X	-488 mV... -512 mV
Gain	-1000 V	200X	-4.88 V... -5.12 V

Test Common Mode Rejection Ratio (CMRR)

- 1 Connect adaptation 1 to the 33250B function generator output.
- 2 Connect the 33250B function generator TTL-output to CH4 of the 54622A oscilloscope for triggering.
- 3 Connect the red and black N2772A probe tips to the red banana outputs of adaptation 1.
- 4 Connect the N2772A output to CH1 of the 54622A oscilloscope.
- 5 Load the appropriate setup file.
- 6 Verify the value complies with the 3458A limits listed in the table below for each output signal at each probe setting.
- 7 Record the value displayed on the 3458A in the Calibration Test Record.

Test	33250B Output Signal	N2772A Setting	54622A setup & limits
CMRR	Sine wave, 60 Hz, 20 V _{pp}	20X	Recall setup 1: < 1.4 div
CMRR	Sine wave, 60 Hz, 20 V _{pp}	200X	Recall setup 2: < 1 div
CMRR	Sine wave, 1 MHz, 20 V _{pp}	20X	Recall setup 3: < 1 div
CMRR	Sine wave, 1 MHz, 20 V _{pp}	200X	Recall setup 4: < 1 div

Cleaning the Probe**Test Bandwidth with power supply**

- 1 Connect adaptation 2 to the 33250B function generator output.
- 2 Connect the red N2772A probe tip to the red banana jack.
- 3 Connect the black N2772A probe tip to the black banana jack.
- 4 Connect the N2772A output to CH1 of the 54622A oscilloscope.
- 5 Load the appropriate setup file.
- 6 Verify the value complies with the 3458A limits listed in the table below for each output signal at each probe setting.
- 7 Record the value displayed on the 3458A in the Calibration Test Record.

Test	33250B Output Signal	N2772A Setting	54622A setup & limits
Bandwidth	Sine wave, 20 MHz, 20 V _{pp}	20X	Recall setup 5: > 3.5 div
Bandwidth	Sine wave, 20 MHz, 20 V _{pp}	200X	Recall setup 6: > 3.5 div

Test Bandwidth with battery power

- 1 Connect adaptation 2 to the 33250B function generator output.
- 2 Connect the red N2772A probe tip to the red banana jack.
- 3 Connect the black N2772A probe tip to the black banana jack.
- 4 Connect the N2772A output to CH1 of the 54622A oscilloscope.
- 5 Disconnect the N2773 power supply and use battery power.
- 6 Load the appropriate setup file.
- 7 Verify the value complies with the 3458A limits listed in the table below for each output signal at each probe setting.
- 8 Record the value displayed on the 3458A in the Calibration Test Record.

Test	33250B Output Signal	N2772A Setting	54622A setup & limits
Bandwidth	Sine wave, 20 MHz, 20 V _{pp}	20X	Recall setup 5: > 3.5 div
Bandwidth	Sine wave, 20 MHz, 20 V _{pp}	200X	Recall setup 6: > 3.5 div

Cleaning the Probe

Disconnect the probe from all power sources and clean it with a soft cloth dampened with a mild soap and water solution. Be careful not to get water in the attenuation switch. Make sure the probe is completely dry before reconnecting it to a power source.

Calibration Test Record

<p>Agilent Technologies</p> <p>Recommended Test Interval: 1 Year Recommended Date of Next Certification: _____ Certification Temperature: _____</p>	<p>N2772A 20 MHz Differential Probe Serial No.: _____ Certification Date: _____ Tested By: _____ _____ _____</p>
--	---

Test	Probe Settings	Limits	Results
Offset	20X	-10 mV ... +10 mV Reading on the 3458A	
Offset	200X	-10 mV ... +10 mV Reading on the 3458A	
Gain	20X	+488 mV ... +512 mV Reading on the 3458A	
Gain	20X	+4.88 V ... +5.12 V Reading on the 3458A	
Gain	200X	+488 mV ... +512 mV Reading on the 3458A	
Gain	200X	+4.88 V ... +5.12 V Reading on the 3458A	
Gain	20X	-488 mV ... -512 mV Reading on the 3458A	
Gain	20X	-4.88 V ... -5.12 V Reading on the 3458A	
Gain	200X	-488 mV ... -512 mV Reading on the 3458A	
Gain	200X	-4.88 V ... -5.12 V Reading on the 3458A	
CMRR	20X	< 1.4 div Reading on oscilloscope	
CMRR	200X	< 1 div Reading on oscilloscope	
CMRR	20X	< 1 div Reading on oscilloscope	
CMRR	200X	< 1 div Reading on oscilloscope	
Bandwidth with power supply	20X	> 3.5 div Reading on oscilloscope	
Bandwidth with power supply	200X	> 3.5 div Reading on oscilloscope	
Bandwidth with battery power	20X	> 3.5 div Reading on oscilloscope	
Bandwidth with battery power	200X	> 3.5 div Reading on oscilloscope	

N2772A Differential Voltage Probe
Calibration Test Record

Safety Notices

This apparatus has been designed and tested in accordance with IEC Publication 1010, Safety Requirements for Measuring Apparatus, and has been supplied in a safe condition. This is a Safety Class I instrument (provided with terminal for protective earthing). Before applying power, verify that the correct safety precautions are taken (see the following warnings). In addition, note the external markings on the instrument that are described under "Safety Symbols."

Warnings

- Before turning on the instrument, you must connect the protective earth terminal of the instrument to the protective conductor of the (mains) power cord. The mains plug shall only be inserted in a socket outlet provided with a protective earth contact. You must not negate the protective action by using an extension cord (power cable) without a protective conductor (grounding). Grounding one conductor of a two-conductor outlet is not sufficient protection.
- Only fuses with the required rated current, voltage, and specified type (normal blow, time delay, etc.) should be used. Do not use repaired fuses or short-circuited fuse-holders. To do so could cause a shock or fire hazard.
- If you energize this instrument by an auto transformer (for voltage reduction or mains isolation), the common terminal must be connected to the earth terminal of the power source.
- Whenever it is likely that the ground protection is impaired, you must make the instrument inoperative and secure it against any unintended operation.
- Service instructions are for trained service personnel. To avoid dangerous electric shock, do not perform any service unless qualified to do so. Do not attempt internal service or adjustment unless another person, capable of

rendering first aid and resuscitation, is present.

- Do not install substitute parts or perform any unauthorized modification to the instrument.
- Capacitors inside the instrument may retain a charge even if the instrument is disconnected from its source of supply.
- Do not operate the instrument in the presence of flammable gasses or fumes. Operation of any electrical instrument in such an environment constitutes a definite safety hazard.
- Do not use the instrument in a manner not specified by the manufacturer.

To clean the instrument

If the instrument requires cleaning: (1) Remove power from the instrument. (2) Clean the external surfaces of the instrument with a soft cloth dampened with a mixture of mild detergent and water. (3) Make sure that the instrument is completely dry before reconnecting it to a power source.

Safety Symbols



Instruction manual symbol: the product is marked with this symbol when it is necessary for you to refer to the instruction manual in order to protect against damage to the product..



Hazardous voltage symbol.



Earth terminal symbol: Used to indicate a circuit common connected to grounded chassis.

Notices

© Agilent Technologies, Inc. 2002

No part of this manual may be reproduced in any form or by any means (including electronic storage and retrieval or translation into a foreign language) without prior agreement and written consent from Agilent Technologies, Inc. as governed by United States and international copyright laws.

Manual Part Number

N2772-92001, September 2002

Print History

N2772-92000, November 1999
N2772-92001, September 2002

Agilent Technologies, Inc.
1900 Garden of the Gods Road
Colorado Springs, CO 80907
USA

Restricted Rights Legend

If software is for use in the performance of a U.S. Government prime contract or subcontract, Software is delivered and licensed as "Commercial computer software" as defined in DFAR 252.227-7014 (June 1995), or as a "commercial item" as defined in FAR 2.101(a) or as "Restricted computer software" as defined in FAR 52.227-19 (June 1987) or any equivalent agency regulation or contract clause. Use, duplication or disclosure of Software is subject to Agilent Technologies' standard commercial license terms, and non-DDD Departments and Agencies of the U.S. Government will receive no greater than Restricted Rights as defined in FAR 52.227-19(c)(1-2) (June 1987). U.S. Government users will receive no greater than Limited Rights as defined in FAR 52.227-14 (June 1987) or DFAR 252.227-7015 (b)(2) (November 1995), as applicable in any technical data.

Document Warranty

The material contained in this document is provided "as is," and is subject to being changed, without notice, in future editions. Further, to the maximum extent permitted by applicable law, Agilent disclaims all warranties, either express or implied, with regard to this manual and any information

contained herein, including but not limited to the implied warranties of merchantability and fitness for a particular purpose. Agilent shall not be liable for errors or for incidental or consequential damages in connection with the furnishing, use, or performance of this document or of any information contained herein. Should Agilent and the user have a separate written agreement with warranty terms covering the material in this document that conflict with these terms, the warranty terms in the separate agreement shall control.

Technology Licenses

The hardware and/or software described in this document are furnished under a license and may be used or copied only in accordance with the terms of such license.

WARNING

A WARNING notice denotes a hazard. It calls attention to an operating procedure, practice, or the like that, if not correctly performed or adhered to, could result in personal injury or death. Do not proceed beyond a WARNING notice until the indicated conditions are fully understood and met.

CAUTION

A CAUTION notice denotes a hazard. It calls attention to an operating procedure, practice, or the like that, if not correctly performed or adhered to, could result in damage to the product or loss of important data. Do not proceed beyond a CAUTION notice until the indicated conditions are fully understood and met.

DECLARATION OF CONFORMITY

According to ISO/IEC Guide 22 and CEN/CENELEC EN 45014

Manufacturer's Name: Agilent Technologies, Inc.
Manufacturer's Address: 1900 Garden of the Gods Road
Colorado Springs, CO
80907, U.S.A.

Declares, that the product

Product Name: Differential Voltage Probe
Model Number(s): N2772A
Product Option(s): This declaration covers all options of the above product(s).

Conforms with the following product standards:

EMC:	Standard	Limit
	IEC 61326-1:1997+A1:1998 / EN 61326-1:1997+A1:1998	
	CISPR 11:1990 / EN 55011:1991	Group 1 Class A ^[1]
	IEC 61000-4-2:1995+A1:1998 / EN 61000-4-2:1995	4kV CD, 8kV AD
	IEC 61000-4-3:1995 / EN 61000-4-3:1995	3 V/m, 80-1000 MHz
	IEC 61000-4-4:1995 / EN 61000-4-4:1995	0.5kV signal lines, 1kV power lines
	IEC 61000-4-5:1995 / EN 61000-4-5:1995	0.5 kV line-line, 1 kV ground line
	IEC 61000-4-6:1996 / EN 61000-4-6:1996	1 cycle, 100%
	IEC 61000-4-11:1994 / EN 61000-4-11:1995	3V, 0.15-80 MHz
	Canada: ICES-001:1998	
	Australia/New Zealand: AS/NZS 2064.1	
Safety:	IEC 61010-1:1990+A1:1992+A2:1995 / EN 61010-1:1993+A2:1995	
	Canada: CSA C22.2 No. 1010.1:1992	

Supplementary Information:

The product herewith complies with the requirements of the Low Voltage Directive 73/23/EEC and the EMC Directive 89/336/EEC (including 93/68/EEC, and carries the CE-marking accordingly (European Union).

^[1]This product was tested in a typical configuration with Agilent Technologies test systems.

Date: 08/21/2000

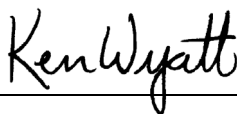

Ken Wyatt / Product Regulations Manager

For further information, please contact your local Agilent Technologies sales office, agent or distributor.

Product Regulations

Performance Criteria

EMC	IEC 61326-1:1997+A1:1998 / EN 61326-1:1997+A1:1998	
	CISPR 11:1990 / EN 55011:1991	
	IEC 61000-4-2:1995+A1:1998 / EN 61000-4-2:1995	A
	IEC 61000-4-3:1995 / EN 61000-4-3:1995	B
	IEC 61000-4-4:1995 / EN 61000-4-4:1995	A
	IEC 61000-4-5:1995 / EN 61000-4-5:1995	A
	IEC 61000-4-6:1996 / EN 61000-4-6:1996	A
	IEC 61000-4-11:1994 / EN 61000-4-11:1995	A
	Canada: ICES-001:1998	
Australia/New Zealand: AS/NZS 2064.1		
Safety	IEC 61010-1:1990+A1:1992+A2:1995 / EN 61010-1:1993+A2:1995	
	Canada: CSA C22.2 No. 1010.1:1992	

Additional Information

The product herewith complies with the requirements of the Low Voltage Directive 73/23/EEC and the EMC Directive 89/336/EEC (including 93/68/EEC) and carries the CE Marking accordingly (European Union).

¹Performance Codes:

A PASS - Normal operation, no effect.

B PASS - Temporary degradation, self recoverable.

C PASS - Temporary degradation, operator intervention required.

D FAIL - Not recoverable, component damage.

Notes:

Sound Pressure Level N/A

Regulatory Information for Canada

ICES/NMB-001

This ISM device complies with Canadian ICES-001.
Cet appareil ISM est conforme à la norme NMB-001 du Canada.

Regulatory Information for Australia/New Zealand

This ISM device complies with Australian/New Zealand AS/NZS 2064.1





Agilent Technologies

Agilent Technologies
Printed in the Malaysia

Manual Part Number
N2772-92002

