

Operating and Service Manual

Agilent U9397A/C FET Solid State Switch (SPDT)



Agilent Technologies

Manufacturing Part Number: U9397-90001

Printed in Malaysia

Print Date: March 2007

© Copyright Agilent Technologies, Inc 2007

Notices

© Agilent Technologies, Inc. 2007

No part of this manual may be reproduced in any form or by any means (including electronic storage and retrieval or translation into a foreign language) without prior agreement and written consent from Agilent Technologies, Inc. as governed by United States and international copyright laws.

Manual Part Number

U9397-90001

Edition

First edition, Mar 2007

Printed in Malaysia

Agilent Technologies, Inc.
Phase 3 Bayan Lepas Free Industrial Zone
Bayan Lepas, Penang 11900 Malaysia

Certification

Agilent Technologies certifies that this product met its published specifications at the time of shipment from the factory. Agilent Technologies further certifies that its calibration measurements are traceable to the United States National Institute of Standards and Technology (NIST, formerly NBS), to the extent allowed by the Institute's calibration facility, and to the calibration facilities of the other International Standards Organization members.

Warranty

The material contained in this document is provided "as is," and is subject to being changed, without notice, in future editions. Further, to the maximum extent permitted by applicable law, Agilent disclaims all warranties, either express or implied, with regard to this manual and any information contained herein, including but not limited to the implied warranties of merchantability and fitness for a particular purpose. Agilent shall not be liable for errors or for incidental or consequential damages in connection with the furnishing, use, or performance of

this document or of any information contained herein. Should Agilent and the user have a separate written agreement with warranty terms covering the material in this document that conflict with these terms, the warranty terms in the separate agreement shall control.

Limitation of Warranty The foregoing warranty shall not apply to defects resulting from the improper or inadequate maintenance by the Buyer, Buyer-supplied software or interfacing, unauthorized modification or misuse, operation outside of the environmental specifications for the product, or improper site preparation or maintenance.

NO OTHER WARRANTY IS EXPRESSED OR IMPLIED. AGILENT SPECIFICALLY DISCLAIMS THE IMPLIED WARRANTIES OR MERCHANTABILITY AND FITNESS FOR A PARTICULAR PURPOSE.

Exclusive Remedies THE REMEDIES PROVIDED HEREIN ARE THE BUYER'S SOLE AND EXCLUSIVE REMEDIES. AGILENT SHALL NOT BE LIABLE FOR ANY DIRECT, INDIRECT, SPECIAL, INCIDENTAL, OR CONSEQUENTIAL DAMAGES, WHETHER BASED ON CONTRACT, TORT, OR ANY OTHER LEGAL THEORY.

Technology Licenses

The hardware and/or software described in this document are furnished under a license and may be used or copied only in accordance with the terms of such license.

Restricted Rights Legend

If software is for use in the performance of a U.S. Government prime contract or subcontract, Software is delivered and licensed as "Commercial computer software" as defined in DFAR 252.227-7014 (June 1995), or as a "commercial item" as defined in FAR 2.101(a) or as "Restricted computer software" as defined in FAR 52.227-19 (June 1987) or any equivalent agency regulation or contract clause. Use, duplication or disclosure of Software is subject to Agilent

Technologies' standard commercial license terms, and non-DOD Departments and Agencies of the U.S. Government will receive no greater than Restricted Rights as defined in FAR 52.227-19(c)(1-2) (June 1987). U.S. Government users will receive no greater than Limited Rights as defined in FAR 52.227-14 (June 1987) or DFAR 252.227-7015 (b)(2) (November 1995), as applicable in any technical data.

Safety Notices

CAUTION

A **CAUTION** notice denotes a hazard. It calls attention to an operating procedure, practice, or the like that, if not correctly performed or adhered to, could result in damage to the product or loss of important data. Do not proceed beyond a **CAUTION** notice until the indicated conditions are fully understood and met.

WARNING

A **WARNING** notice denotes a hazard. It calls attention to an operating procedure, practice, or the like that, if not correctly performed or adhered to, could result in personal injury or death. Do not proceed beyond a **WARNING** notice until the indicated conditions are fully understood and met.

WEEE Compliance



This product complies with the WEEE Directive (2002/96/EC) marking requirements. The affixed label indicates that you must not discard this electrical/electronic product in domestic household waste.

Product Category: With reference to the equipment types in the WEEE Directive Annex I, this product is classed as a "Monitoring and Control Instrumentation" product.

Do not dispose in domestic household waste.

To return unwanted products, contact your local Agilent office, or see www.agilent.com for more information.

Printing Copies of Documentation from the Web

To print copies of documentation from the Web, download the PDF file from the Agilent web site:

- Go to <http://www.agilent.com>.
- Enter the document's part number (located on the title page) in the Quick Search box.
- Click GO.
- Click on the hyperlink for the document.
- Click the printer icon located in the tool bar.

Contacting Agilent (Americas, Asia Pacific & Japan)

Contacting Agilent (Americas, Asia Pacific & Japan)

Online assistance: www.agilent.com/find/assist			
Americas			
Brazil (tel) (+55) 11 3351 7012 (fax) (+55) 11 3351 7024	Canada (tel) +1 877 894 4414 (alt) +1 303 662 3369 (fax) +1 800 746 4866	Mexico (tel) 1 800 254 2440 (fax) 1 800 254 4222	United States (tel) 800 829 4444 (alt) (+1) 303 662 3998 (fax) 800 829 4433
Asia Pacific and Japan			
Australia (tel) 1 800 802 540 (fax) 1 800 681 776 (fax) 1 800 225 539	China (tel) 800 810 0508 (fax) 800 810 0507	Hong Kong (tel) 800 933 229 (fax) 800 900 701	India (tel) 1600 112 626 (fax) 1600 113 040
Japan (Bench) (tel) 0120 421 345 (alt) (+81) 426 56 7832 (fax) 0120 01 2144	Japan (On-Site) (tel) 0120 421 345 (alt) (+81) 426 56 7832 (fax) 0120 012 114	Singapore (tel) 1 800 275 0880 (fax) (+65) 6755 1214	South Korea (tel) 080 778 0011 (fax) 080 778 0013
Taiwan (tel) 0800 047 669 (fax) 0800 047 667 (fax) 886 3492 0779	Thailand (tel) 1 800 2758 5822 (fax) 1 800 656 336	Malaysia (tel) 1800 880 399 (fax) 1800 801 054	
(tel) = primary telephone number; (alt) = alternate telephone number; (fax) = FAX number; * = in country number 5/6/05			

Contacting Agilent (Europe)

Online assistance: www.agilent.com/find/assist			
Europe			
Austria (tel) 0820 87 44 11* (fax) 0820 87 44 22	Belgium (tel) (+32) (0)2 404 9340 (fax) (+32) (0)2 404 9395	Denmark (tel) (+45) 7013 1515 (fax) (+45) 7013 1555	Finland (tel) (+358) 10 855 2100 (fax) (+358) (0) 10 855 2923
France (tel) 0825 010 700* (fax) 0825 010 701*	Germany (tel) 01805 24 6333* (fax) 01805 24 6336*	Ireland (tel) (+353) (0)1 890 924 204 (fax) (+353) (0)1 890 924 024	Israel (tel) (+972) 3 9288 504 (alt) (+972) 3 9288 544 (fax) (+972) 3 9288 520
Italy (tel) (+39) (0)2 9260 8484 (fax) (+39) (0)2 9544 1175	Luxemburg (tel) (+32) (0)2 404 9340 (fax) (+32) (0)2 404 9395	Netherlands (tel) (+31) (0)20 547 2111 (fax) (+31) (0)20 547 2190	Russia (tel) (+7) 095 797 3963 (alt) (+7) 095 797 3900 (fax) (+7) 095 797 3902
Spain (tel) (+34) 91 631 3300 (fax) (+34) 91 631 3301	Sweden (tel) 0200 88 22 55* (alt) (+46) (0)8 5064 8686 (fax) 020 120 2266*	Switzerland (French) (tel) 0800 80 5353 opt. 2* (fax) (+41) (0)22 567 5313	Switzerland (German) (tel) 0800 80 5353 opt. 1* (fax) (+41) (0)1 272 7373
Switzerland (Italian) (tel) 0800 80 5353 opt. 3* (fax) (+41) (0)22 567 5314	United Kingdom (tel) (+44) (0)7004 666666 (fax) (+44) (0)7004 444555		
(tel) = primary telephone number; (alt) = alternate telephone number; (fax) = FAX number; * = in country number 5/6/05			

Contents

Notices	ii
WEEE Compliance	iii
Printing Copies of Documentation from the Web	iii
Contacting Agilent (Americas, Asia Pacific & Japan).	iv
Contacting Agilent (Europe)	v
General Information	1
Solid State Switch Overview	1
Features	2
Control Logic.	3
Specifications	4
Environmental Specifications	6
Physical Specifications.	7
Installation	8
Initial Inspection	8
Operating Instruction	9
Operator's Check.	9
Performance Tests	10
Service Instructions	10
Adjustment.	10
Repair.	10
Maintenance.	10

General Information

FET Solid State Switch Overview

Agilent U9397A/C are GaAs FET Monolithic Microwave Integrated Circuit (MMIC) based solid state switches which provide superior performance in isolation, settling time, video leakage and insertion loss across a broad operating frequency range.



Figure 1 U9397A/C FET Solid State Switches

Table 1 shows the two models of FET solid state switches available.

Table 1 List of FET Solid State Switches

Model	Frequency Range	Connector Type
U9397A	300 kHz to 8 GHz	SMA (f)
U9397C	300 kHz to 18 GHz	SMA (f)

General Information

The U9397A/C are particularly suitable for measuring sensitive devices and components such as mixers and low noise amplifiers, where video leakage may cause damage or reliability issues. Typical settling time of 350 μ s makes these switches ideal for high-speed switching applications in instrumentation, communications, radar and other test systems. High isolation minimizes crosstalk between measurements, ensuring accurate testing and improving yields.

Features

- Prevent damage to sensitive devices with low video leakage < 10 mVpp
- Minimize crosstalk with exceptionally high isolation 100 dB at 8 GHz.
- Maintain fast throughput with industry leading settling time for FET switches of 350 μ s
- Integrated TTL/CMOS driver eliminated the need for external drivers

Circuit Logic

Agilent U9397A/C switches have a GaAs FET MMIC at each RF ports, and the integrated TTL/CMOS driver is configured in such a way that when either the RF1 or RF2 port is not selected to RFCOM, it will be terminated to 50 Ohm as shown in Figure 2.

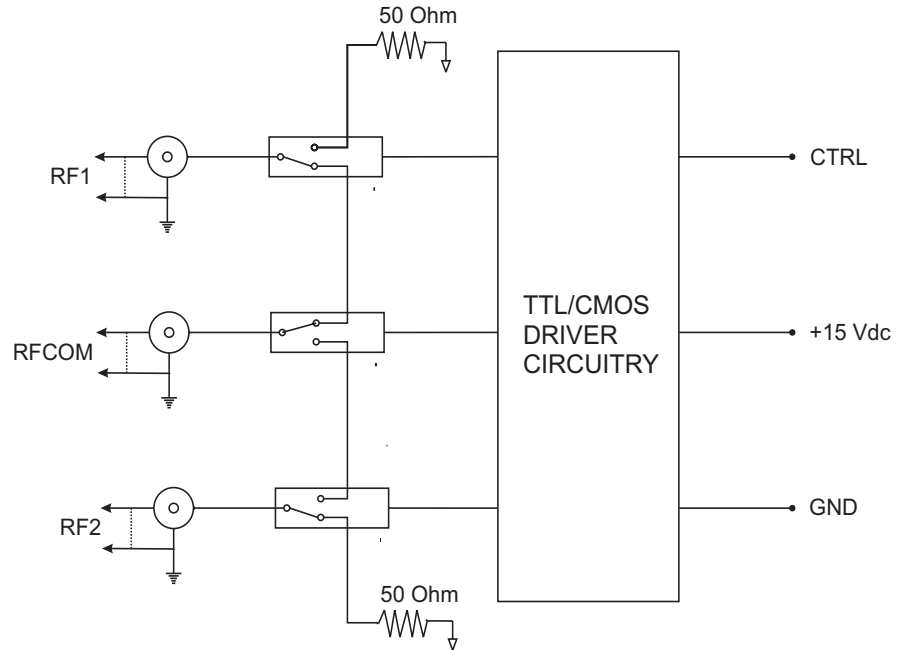

Figure 2 Block Diagram on the Operation of U9397A/C FET Solid State Switches

Table 2 Switch Operation Logic

CTRL Logic	RFCOM to RF1	RFCOM to RF2
0	Low Loss	Isolated
1	Isolated	Low Loss

Specifications

Specifications refer to the performance standards or limits against which the solid state switches are tested.

Typical characteristics are included for additional information only and they are not specifications. These are denoted as "typical", "nominal" or "approximate" and are printed in italics.

Table 3 RF Specifications for U9397A/C FET Solid State Switches

Agilent Model Number	U9397A	U9397C
Frequency Range	300 kHz to 8 GHz	300 kHz to 18 GHz
Insertion Loss	< 3.0 dB (300 kHz to 4 GHz) < 3.5 dB (4 to 8 GHz)	< 5.0 dB (300 kHz to 8 GHz) < 6.5 dB (8 to 18 GHz)
Isolation	100 dB	90 dB
Return Loss - ON & Common Port	> 15 dB	> 10 dB
Return Loss - OFF Port	> 18 dB	> 13 dB
Settling time	<i>350 μs typical</i>	<i>350 μs typical</i>
Switching Speed (Rise/Fall) ¹	<i>5/0.5 μs typical</i>	<i>5/0.5 μs typical</i>
Video Leakage	<i><10 mVpp typical</i>	<i><10 mVpp typical</i>
Characteristic Impedance	<i>50 Ohms nominal</i>	<i>50 Ohms nominal</i>
Connectors	SMA (f)	SMA (f)

1. Switching speed is based on 10% to 90% RF.

Table 4 Absolute Maximum Rating¹ for U9397A/C FET Solid State Switches

	Min	Max	Unit
RF Input Power (Average)			
U9397A		+29	dBm
U9397C		+27	dBm
DC Voltage to RF Port	-2.5	+2.5	V
Current Sourcing at RF1 or RF2 ²		60	mA
Vdc Bias	+12	+24	V
CTRL Input High Voltage	+2.4	+5	V
CTRL Input Low Voltage	0	+0.8	V

1. Operation in excess of any one of these may result in permanent damage to the products.
2. Sinking not allowed.

Environmental Specifications

The U9397A/C solid state switches are designed to fully comply with Agilent Technologies' product operating environmental specifications as shown in [Table 5](#).

Table 5 *U9397A/C FET Solid State Switches Environmental Specifications*

Temperature:	
Operating	-40°C to +65°C
Storage	-65°C to +85°C
Cycling	-65°C to +150°C, 10 cycles @ 20°C per minute, 20 minutes dwell time per MIL-STD-833F, Method 1010.8, Condition C (modified)
Humidity:	
Operating	50% to 95% RH at 40°C, one 24 hour cycle, repeated 5 times
Storage	<95% RH at 40°C, 5 days
Shock:	
Half-sine, smoothed	1000 G @ 0.5 ms, 3 shock pulses per orientation, 18 total per MIL-STD-833F, Method 2002.4, Condition B (modified)
Vibration:	
Broadband, random	50 to 2000 Hz, 7.0 G rms, 15 minutes, per MIL-STD-833F, Method 2026-1 (modified)
Altitude:	
Storage	<15,300 meters (50,000 feet)
ESD Immunity:	
Direct discharge	4 kV (to outer conductor) per IEC 61000-4-2
Air discharge	8 kV (to center conductor) per IEC 61000-4-2

Physical Specifications

Table 6 and Figure 3 illustrate the physical specifications of U9397A/C solid state switches.

Table 6 U9397A/C FET Solid State Switches Physical Specifications

Dimensions	Per Figure 3
Net weight, kg (lb)	0.055 (0.121)

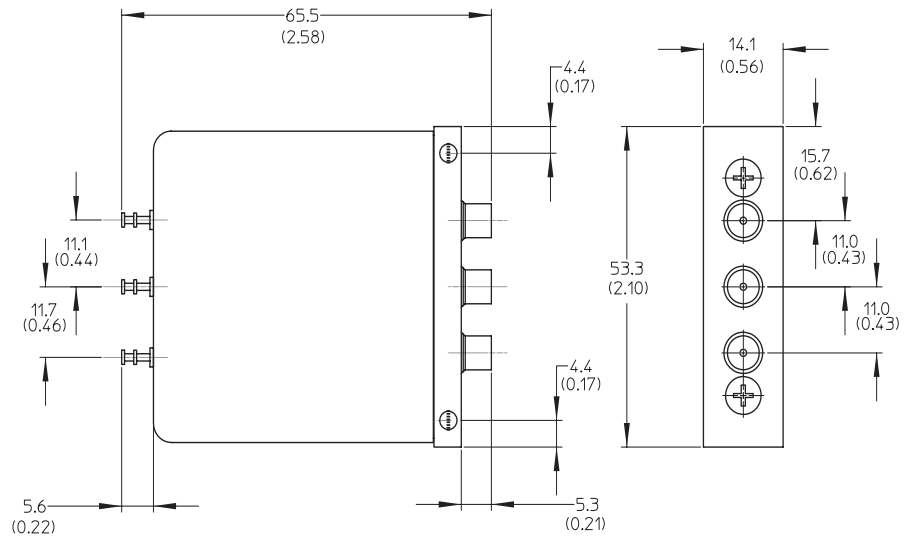

Figure 3 Dimensions of U9397A/C FET Solid State Switches

Installation

- Initial Inspection**
1. Inspect the shipping container for damage. If the shipping container or cushioning material is damaged, it should be kept until the contents of the shipment have been checked for completeness and the instrument has been checked both mechanically and electrically.
 - Check for mechanical damage such as scratches or dents.
 - Procedures for checking electrical performance are given under “Operator’s Check” or “Performance Tests”.
 2. If the contents are incomplete, if there is mechanical damage or defect, or if the instrument does not pass the electrical performance test, contact the nearest Agilent Technologies Sales and Service office. Refer to the Service and Support information in the front matter of this manual. Agilent Technologies will arrange for repair or replacement of the damaged or defective equipment. Keep the shipping materials for the carrier’s inspection.
 3. If you are returning the instrument under warranty or for service, repackaging the instrument requires original shipping containers and materials or their equivalents. Agilent Technologies can provide packaging materials identical to the original materials. Refer to Service and Support information in the front matter of this manual for the Agilent Technologies nearest you. Attach a tag indicating the type of service required, return address, model number, and serial number. Mark the container **FRAGILE** to insure careful handling. In any correspondence, refer to the instrument by model number and serial number.

Operating Instruction

Operator's Check

The operator's check is supplied to allow the operator to make a quick check of the solid state switches prior to use or if a failure is suspected.

CAUTION

The RF port center conductors connect directly to the GaAs MMIC and are thus sensitive to electrostatic discharge (ESD). ESD exceeding the level specified in [Table 5](#) or RF power applied is greater than the maximum specified as in [Table 4](#) may cause permanent damage to the device.

Description

The solid state switch is connected to a network analyzer configured for the s-parameter measurement. The network analyzer may be set to sweep over the whole or selected frequency range of the solid state switch to be verified. The S_{21} (insertion loss) measurement is the best way to determine if the switch is faulty by applying the appropriate logic to the CTRL pin.

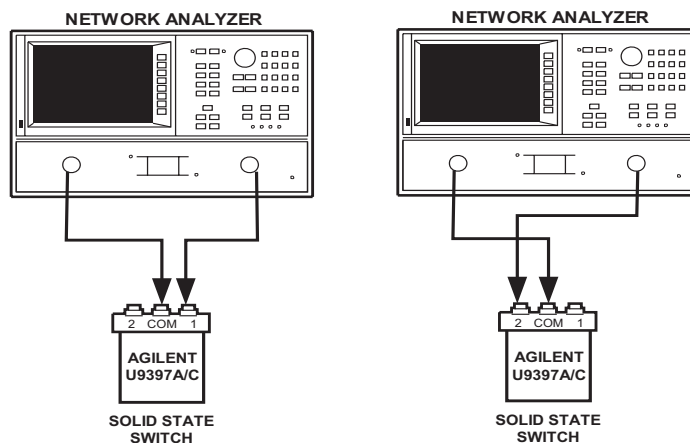

Figure 4 Connection to Perform Quick Check

Performance Tests

Quick-Check Procedure

1. Connect RFCOM of the switch to Port 1 of the network analyzer and either RF1 or RF2 to Port 2 as illustrated in [Figure 4](#).
2. Ensure that +24Vdc and GND are connected.
3. If RF1 of the switch is connected to Port 2, apply logic '0' to CTRL. This should yield low loss from RF COM to RF1. S_{21} should not exceed specification in [Table 3](#).
4. If RF2 of the switch is connected to Port 2, apply logic '1' to CTRL. This should yield low loss from RF COM to RF2. S_{21} should not exceed specification in [Table 3](#).

Performance Tests

The solid state switches can be tested to the accuracy of the specifications with a network analyzer or equivalent equipment of suitable accuracy. If a network analyzer is available, test the instrument using the procedure in the analyzer's operating manual.

Service Instructions

Adjustment

The solid state switches do not have internal adjustments and should not be opened.

Repair

The U9397A/C solid state switches are not recommended for repair as most components are not easily removed.

Maintenance

The connectors, particularly the connector faces, must be kept clean. For instruction on connecting and care of your connectors, refer to the Microwave Connector Care Quick Reference Card (08510-90360).