



Agilent Technologies

P2D Simulation

August 2005

Notice

The information contained in this document is subject to change without notice.

Agilent Technologies makes no warranty of any kind with regard to this material, including, but not limited to, the implied warranties of merchantability and fitness for a particular purpose. Agilent Technologies shall not be liable for errors contained herein or for incidental or consequential damages in connection with the furnishing, performance, or use of this material.

Warranty

A copy of the specific warranty terms that apply to this software product is available upon request from your Agilent Technologies representative.

Restricted Rights Legend

Use, duplication or disclosure by the U. S. Government is subject to restrictions as set forth in subparagraph (c) (1) (ii) of the Rights in Technical Data and Computer Software clause at DFARS 252.227-7013 for DoD agencies, and subparagraphs (c) (1) and (c) (2) of the Commercial Computer Software Restricted Rights clause at FAR 52.227-19 for other agencies.

© Agilent Technologies, Inc. 1983-2005
395 Page Mill Road, Palo Alto, CA 94304 U.S.A.

Acknowledgments

Mentor Graphics is a trademark of Mentor Graphics Corporation in the U.S. and other countries.

Microsoft[®], Windows[®], MS Windows[®], Windows NT[®], and MS-DOS[®] are U.S. registered trademarks of Microsoft Corporation.

Pentium[®] is a U.S. registered trademark of Intel Corporation.

PostScript[®] and Acrobat[®] are trademarks of Adobe Systems Incorporated.

UNIX[®] is a registered trademark of the Open Group.

Java[™] is a U.S. trademark of Sun Microsystems, Inc.

SystemC[®] is a registered trademark of Open SystemC Initiative, Inc. in the United States and other countries and is used with permission.

Contents

1 P2D Simulation

Performing a P2D Simulation	1-2
Example.....	1-3
Using the P2D file.....	1-6
Using Terms in a P2D Simulation	1-6

Index

Chapter 1: P2D Simulation

The P2D simulator can be used to generate a *.p2d* file, which contains S-parameters that can be used to develop component models. A P2D simulation generates power-dependent S-parameters, which can then be used in a behavioral model for faster, system-level simulations. The resulting *.p2d* file can be accessed by components such as AmplifierP2D (System-Data Models palette) by selecting *P2D Filename* as the Parameter Entry Mode for the *P2DFile=* parameter.

Refer to the following topics for details on P2D simulation:

- [“Performing a P2D Simulation” on page 1-2](#) describes the minimum setup requirements for generating a *.p2d* file from a simulation.
- [“Example” on page 1-3](#) is a detailed setup for generating a *.p2d* file from a simulation.
- [“Using the P2D file” on page 1-6](#) describes how to use the file with a component that accepts file-based parameters.
- [“Using Terms in a P2D Simulation” on page 1-6](#) describes how to terminate the circuit with Term components instead of sources and loads.
- The topic “P2D Format” in the chapter “Working with Data Files” in the *Using Circuit Simulators* documentation describes how to write a *.p2d* file using a text editor. This is as an alternate method of creating a *.p2d*.

Note You must have the LSSP license to run the simulator. You can build the examples in this chapter without the license, but you will not be able to simulate them.

Performing a P2D Simulation

Start by creating your design, then add current probes and identify the nodes from which you want to collect data. For a successful analysis:

- Add the P2D control component to the schematic and double-click to edit it. Fill in these fields under the Freq tab:
 - Specify the name of the *.p2d* file. This is where the S-parameters that are generated by the simulation will be saved. The *.p2d* file will be saved in the project in the same location where dataset (*.ds*) files are saved (*/data* directory), unless you specify a path.
 - Select a sweep type. For a single point, enter the frequency. For a linear or logarithmic sweep, elect to define the frequency sweep with start/stop or center/span values.
- For a power sweep, fill in these fields under the Power tab:
 - Select a sweep type. For a single point, enter the power level for that point. For a linear or logarithmic sweep, define the power levels of the sweep with start/stop or center/span values. Power is in dBm.
- The P2D control component can extract noise characteristics to the *.p2d* file. You can control this noise characterization and other simulation parameters by placing an Options component on the schematic. For more information, refer to the topic “Using the Options Component” in the chapter “Simulation Basics” in the *Using Circuit Simulators* documentation.
- You can perform budget calculations as part of the simulation. For more information on budget analyses, refer to the chapter “Using Circuit Simulators for RF System Analysis” in the *Using Circuit Simulators* documentation.
- You can apply the Krylov subspace solution option for faster calculations of circuits with large numbers of nonlinear devices or large numbers of harmonics. Do not select this option for one-tone or power-sweep problems. See the topic “Selecting a Solver” in the chapter “Harmonic Balance Basics” in the *Harmonic Balance Simulation* documentation for instructions on how to use this option.
- You can use previous simulation solutions to speed up the simulation process. For more information, see the topic “Reusing Simulation Solutions” in the chapter “Harmonic Balance Basics” in the *Harmonic Balance Simulation* documentation.

For details about each field, click *Help* from the dialog box.

Example

This example simulates an amplifier, sweeping input power over various levels. [Figure 1-1](#) illustrates the setup for simulating a simple amplifier.

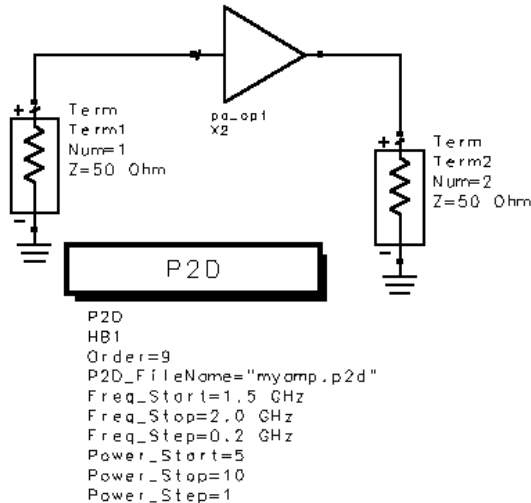

Figure 1-1. Setup for P2D simulation

1. From the **Simulation-LSSP** palette, select an **P2D** simulation component, place it on the schematic, and double-click to edit it.
2. Select the **Frequency** tab. In the *P2D file to output* field, enter a name for the *.p2d* file. This is the file that will be generated by the simulation. The filename must be in quotes. The default filename is *"default.p2d"*.
3. In the *Order* field, accept the default value of 3 or edit this value.
4. Select a sweep type and values for *Start*, *Stop*, and *Step-size* as desired. Optionally, you can select a sweep plan.

5. Select the **Power** tab and select a sweep type, as well as values for *Start*, *Stop*, and *Step-size* as desired. Optionally, you can select a sweep plan. Power is in dBm.

Note The Krylov option should not be selected for one-tone problems such as this, especially when they involve sweeping.

6. **Simulate.** The result is a *.p2d* file that can be used in subsequent simulations.

Note that with these power sweep settings, gain compression will occur in the amplifier. You can see this if you set up and run this simulation, then plot the results HB.S(2,1) on a rectangular plot. You can view the *.p2d* file with any ASCII text editor. A portion of the file from the example is shown here.

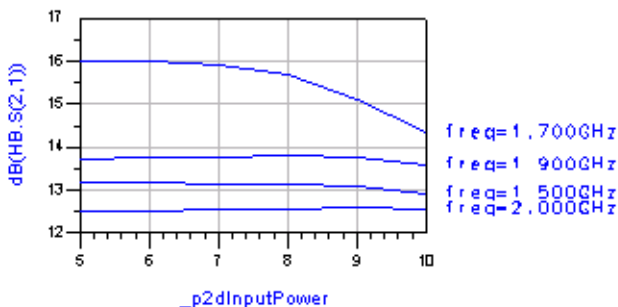

```

BEGIN ACDATA
# AC(MHZ S RI R 50 FC 1 0)
! small signal s-parameter
% F n11x n11y n21x n21y n12x n12y n22x n22y
1500 -0.14973 -0.74466 1.05898e-003 -4.57539 -5.87788e-002 -3.51371e-002 0.841147 -0.275706
1700 -3.54194e-002 5.47026e-002 -5.5386 -2.94283 -9.49884e-002 4.81790e-002 0.287816 -0.647277
1900 0.506917 -8.94668e-002 -4.61943 1.34196 -3.60905e-002 8.40664e-002 4.42222e-002 -0.382819
2000 0.566256 -0.241273 -3.64262 2.06492 -1.75349e-002 8.20927e-002 4.42686e-002 -0.321673
! power dependent s-parameter
% F
1500
% P1 P2 n11x n11y n21x n21y n12x n12y n22x n22y
5 18.1744 -0.14594 -0.75056 3.43087e-002 -4.55728 -5.81017e-002 -3.66150e-002 0.799862 -0.247955
6 19.1668 -0.145027 -0.751947 4.20916e-002 -4.55323 -5.73255e-002 -3.76813e-002 0.766918 -0.225389
7 20.158 -0.143936 -0.753596 5.12981e-002 -4.54852 -5.58564e-002 -3.92082e-002 0.715344 -0.190726
8 21.1449 -0.142695 -0.75555 6.20423e-002 -4.54154 -5.39404e-002 -4.09731e-002 0.651845 -0.149458
9 22.0968 -0.141491 -0.758293 7.63355e-002 -4.51623 -5.18580e-002 -4.27849e-002 0.583724 -0.106445
10 22.9241 -0.140564 -0.763445 0.101229 -4.4268 -4.99511e-002 -4.43975e-002 0.521083 -6.77973e-002
% F
1700
% P1 P2 n11x n11y n21x n21y n12x n12y n22x n22y
5 21.0224 -6.04337e-002 4.76748e-002 -5.51531 -3.09798 -0.102685 4.12691e-002 0.237226 -0.561646
6 22.0197 -6.64604e-002 4.68597e-002 -5.49727 -3.12597 -0.106569 3.65968e-002 0.207403 -0.509516
7 22.9328 -7.77040e-002 4.93914e-002 -5.41591 -3.1412 -0.1106 3.15724e-002 0.175171 -0.455106
8 23.7037 -9.74298e-002 5.46652e-002 -5.23131 -3.13353 -0.114291 2.68724e-002 0.145083 -0.405278
9 24.0993 -8.99288e-002 1.09087e-002 -4.85087 -2.97041 -0.116225 2.43362e-002 0.128901 -0.378963
10 24.3455 -5.62783e-002 -4.99003e-002 -4.46457 -2.69559 -0.117431 2.27256e-002 0.118628 -0.362467
% F
1900
% P1 P2 n11x n11y n21x n21y n12x n12y n22x n22y
5 18.7339 0.501498 -8.06491e-002 -4.67845 1.31828 -3.72235e-002 8.40764e-002 3.84839e-002 -0.374854
6 19.7564 0.500116 -7.85094e-002 -4.69323 1.31235 -3.74907e-002 8.41649e-002 3.65473e-002 -0.372692
7 20.783 0.49845 -7.59467e-002 -4.71075 1.30514 -3.79189e-002 8.43492e-002 3.29121e-002 -0.368753
8 21.8042 0.496769 -7.26969e-002 -4.72576 1.29569 -3.90612e-002 8.46008e-002 2.40136e-002 -0.357892
9 22.7653 0.496553 -6.66354e-002 -4.70825 1.27675 -4.14758e-002 8.47738e-002 7.27654e-003 -0.335699
10 23.5895 0.499408 -5.39443e-002 -4.61837 1.23452 -4.44986e-002 8.48838e-002 -1.32114e-002 -0.308663

```

```

% F
2000
% P1 P2 n11x n11y n21x n21y n12x n12y n22x n22y
5 17.5059 0.564973 -0.235164 -3.68053 2.06416 -1.82402e-002 8.21746e-002 4.01378e-002 -0.315699
6 18.5231 0.564627 -0.233628 -3.6902 2.06395 -1.84052e-002 8.22194e-002 3.89939e-002 -0.314172
7 19.5444 0.564185 -0.231743 -3.70223 2.0637 -1.86000e-002 8.22987e-002 3.74514e-002 -0.31222
8 20.57 0.563633 -0.22947 -3.71678 2.06336 -1.88476e-002 8.24501e-002 3.50802e-002 -0.309386
9 21.5946 0.563129 -0.226756 -3.73142 2.06182 -1.93544e-002 8.27421e-002 3.00353e-002 -0.303221
10 22.5766 0.563986 -0.222907 -3.72765 2.05035 -2.07086e-002 8.32049e-002 1.85446e-002 -0.287915
END ACDATA
BEGIN NDATA
# AC(MHZ S MA R 50 )
! noise parameters
% F NFMIN N11X N11Y RN
1500 0.805004 0.729762 76.3737 0.375956
1700 0.773222 0.472086 85.1077 0.150943
1900 0.778457 0.32785 63.6208 0.142144
2000 0.791368 0.357158 52.3085 0.165415
END NDATA

```

Using the P2D file

Once the *.p2d* file is generated, you can use it to describe the behavior of a component, such as the AmplifierP2D, using file-based parameters.

1. From the **System-Data Models** palette, select the **AmplifierP2D** component and place it on the schematic. Double-click to edit it.
2. Select **P2DFile=** from the Select Parameter list box. In the **File Name** field, enter the name of the *.p2d* file. Alternatively, user the Browser to select a data file from within the project or click **Data files list** to select a file from all files found based on the paths set for the DATA_FILES variable. If using a file outside the project, include the complete path.

Using Terms in a P2D Simulation

When setting up a circuit for a P2D simulation, you should substitute Term components for both the source and load. By setting the Power parameters on the P2D simulation component, you can sweep input power to the circuit (see example).

Index

P

P2D file

using, 1-6

P2D simulations

about, 1-1

performing, 1-2

Term component, 1-6

T

Term component

P2D simulations, 1-6

