



Agilent Technologies

**Vendor Component Libraries
S-Parameter Transistor Library**

August 2005

Notice

The information contained in this document is subject to change without notice.

Agilent Technologies makes no warranty of any kind with regard to this material, including, but not limited to, the implied warranties of merchantability and fitness for a particular purpose. Agilent Technologies shall not be liable for errors contained herein or for incidental or consequential damages in connection with the furnishing, performance, or use of this material.

Warranty

A copy of the specific warranty terms that apply to this software product is available upon request from your Agilent Technologies representative.

Restricted Rights Legend

Use, duplication or disclosure by the U. S. Government is subject to restrictions as set forth in subparagraph (c) (1) (ii) of the Rights in Technical Data and Computer Software clause at DFARS 252.227-7013 for DoD agencies, and subparagraphs (c) (1) and (c) (2) of the Commercial Computer Software Restricted Rights clause at FAR 52.227-19 for other agencies.

© Agilent Technologies, Inc. 1983-2005
395 Page Mill Road, Palo Alto, CA 94304 U.S.A.

Acknowledgments

Mentor Graphics is a trademark of Mentor Graphics Corporation in the U.S. and other countries.

Microsoft[®], Windows[®], MS Windows[®], Windows NT[®], and MS-DOS[®] are U.S. registered trademarks of Microsoft Corporation.

Pentium[®] is a U.S. registered trademark of Intel Corporation.

PostScript[®] and Acrobat[®] are trademarks of Adobe Systems Incorporated.

UNIX[®] is a registered trademark of the Open Group.

Java[™] is a U.S. trademark of Sun Microsystems, Inc.

SystemC[®] is a registered trademark of Open SystemC Initiative, Inc. in the United States and other countries and is used with permission.

Contents

1 S-Parameter Transistor Library

Schematic Design.....	1-2
1-Port Models	1-2
2-Port Models	1-2
Frequency Ranges	1-4
Agilent Technologies S-Parameters.....	1-5
Alpha Industries S-Parameters.....	1-5
Fujitsu S-Parameters	1-5
Harris S-Parameters	1-6
Litton S-Parameters.....	1-6
Microwave Technology S-Parameters	1-6
Mitsubishi S-Parameters.....	1-7
Motorola S-Parameters.....	1-7
NEC S-Parameters	1-8
Philips S-Parameters	1-8
Raytheon S-Parameters	1-8
Siemens S-Parameters.....	1-9
Sony S-Parameters	1-9
Toshiba S-Parameters	1-10

Index

Chapter 1: S-Parameter Transistor Library

The S-Parameter Transistor Library is included with all Advanced Design System simulators. The library consists of S-Parameter data files representing 4,618 devices from 14 manufacturers. Many of these files represent the same device, measured under differing DC operating biases. All contain 50 ohm S-parameters. Some contain noise parameters. The models were extracted from data provided by these manufacturers.

Note The library itself is a set of binary files, *S-Parameter_Library.library*, under *\$HPEESOF_DIR/ComponentLibs/models*.

The S-parameter transistor library groups available for selection from the Schematic windows are:

- “Agilent Technologies S-Parameters” on page 1-5
- “Alpha Industries S-Parameters” on page 1-5
- “Fujitsu S-Parameters” on page 1-5
- “Harris S-Parameters” on page 1-6
- “Litton S-Parameters” on page 1-6
- “Microwave Technology S-Parameters” on page 1-6
- “Mitsubishi S-Parameters” on page 1-7
- “Motorola S-Parameters” on page 1-7
- “NEC S-Parameters” on page 1-8
- “Philips S-Parameters” on page 1-8
- “Raytheon S-Parameters” on page 1-8
- “Siemens S-Parameters” on page 1-9
- “Sony S-Parameters” on page 1-9
- “Toshiba S-Parameters” on page 1-10

Schematic Design

This section describes the schematic design of the S-Parameter Transistor Library components and specifies the simulation models that are incorporated in the design.

1-Port Models

Figure 1-1 shows how a 1-port S-parameter data component appears when placed in the Schematic design window. The schematic symbol is derived from standard artwork in the *\$HPEESOF_DIR/ComponentLibs/symbols* directory. The 1-port S-parameters are represented by the appropriate schematic symbol, such as the DIODE shown in the example. The annotation consists of the component name and the default component ID prefix (in this case, SNP), and the bias condition. No component parameters are associated with the schematic component.

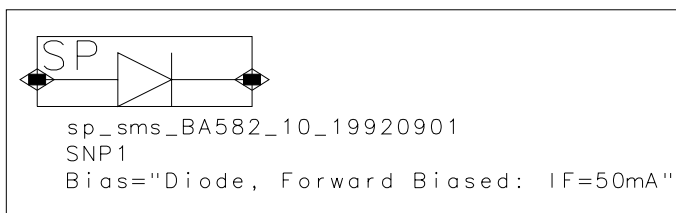

Figure 1-1. 1-Port S-Parameter Data Component Example

The S-parameter data 1-port library components are suitable for placement in any Advanced Design System schematic.

2-Port Models

Figure 1-2 shows how a 2-port S-parameter data component appears when placed in the Schematic design window. The schematic symbol is derived from standard artwork in the *\$HPEESOF_DIR/ComponentLibs/symbols* directory. The 2-port S-parameters are represented by the NPN, PNP, FET, MOSFET and other standard symbols, as appropriate to the particular device associated with the data file. The annotation consists of the component name and the default component ID prefix (in this case, SNP), and the bias condition. No component parameters are associated with the schematic component.

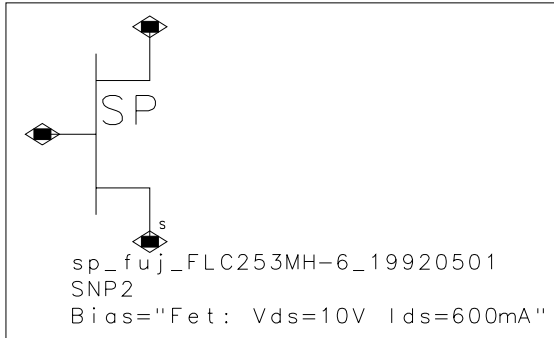

Figure 1-2. 2-Port S-Parameter Data Component Example

The S-parameter data 2-port library components are suitable for placement in any Advanced Design System schematic.

Frequency Ranges

You can now view frequency ranges as a component parameter. The images below display this capability in a component and in the Edit Component Parameters.

Edit
Frequency Range

sp_hp_AT-30533_1_19921201

Instance Name (name[<start:stop>])

SNP

Select Parameter

```
( Lib="sp_hp" )
( File="sp_hp_AT-30533_1_19921201"
( Bias="Bjt: Vce=1V Ic=1mA" )
( Frequency="{0.10 - 5.00} GHz" )
( Noise Frequency="{0.50 - 2.40} GHz"
( Temp=27.0 )
```

Display parameter on schematic

Add Cut Paste Component Options...

Frequency : S-Parameter Frequency Range

OK Apply Cancel Reset Help

Display
Frequency Range

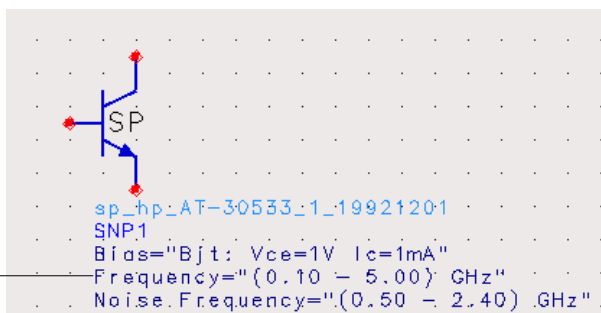

Agilent Technologies S-Parameters

For modeling specifications, see [“Schematic Design” on page 1-2](#).

The 740 components installed in the library group originate from the Agilent Technologies S-parameter Performance and Transistor Library V4.11 data disk. The data files associated with the components contain linear 2-port or 1-port S-parameter data and, when provided by the vendor, 2-port noise parameters. The naming convention for the components is *sp_hpa_<part number>_<index>_<extraction date>*.

A numeric index is used in conjunction with the part number for the component name when multiple operating bias conditions for the part have been supplied by the vendor. The indices correspond to the operating bias condition documented in the descriptive text of the dialog box when this library group is selected from the library list.

Alpha Industries S-Parameters

For modeling specifications, see [“Schematic Design” on page 1-2](#).

The 208 components installed in the library group are supplied to EEsof by the vendor. The data files associated with the components contain linear 2-port or 1-port S-parameter data and, when provided by the vendor, 2-port noise parameters. The naming convention for the components is *sp_aii_<part_number>_<index>_<extraction date>*.

A numeric index is used in conjunction with the part number for the component name when multiple operating bias conditions for the part have been supplied by the vendor. The indices correspond to the operating bias condition documented in the descriptive text of the dialog box when this library group is selected from the library list.

Fujitsu S-Parameters

For modeling specifications, see [“Schematic Design” on page 1-2](#).

The 66 components installed in the library group originate from the Fujitsu Microwave Semiconductor Device Library data disk dated May 1992. The data files associated with the components contain linear 2-port S-parameter data and, when provided by the vendor, 2-port noise parameters. The naming convention for the components is *sp_fuj_<part_number>_<index>_<extraction date>*.

A numeric index is used in conjunction with the part number for the component name when multiple operating bias conditions for the part have been supplied by the vendor. The indices correspond to the operating bias condition documented in the descriptive text of the dialog box when this library group is selected from the library list.

Harris S-Parameters

For modeling specifications, see [“Schematic Design” on page 1-2](#).

The 12 components installed in the library group are supplied by the vendor. The data files associated with the components contain linear 2-port S-parameter data and, when provided by the vendor, 2-port noise parameters. The naming convention for the components is *sp_hm_<part number>_<index>_<extraction date>*.

A numeric index is used in conjunction with the part number for the component name when multiple operating bias conditions for the part have been supplied by the vendor. The indices correspond to the operating bias condition documented in the descriptive text of the dialog box when this library group is selected from the library list.

Litton S-Parameters

For modeling specifications, see [“Schematic Design” on page 1-2](#).

The 12 components installed in the library group are supplied by the vendor. The data files associated with the components contain linear 2-port S-parameter data and, when provided by the vendor, 2-port noise parameters. The naming convention for the components is *sp_lit_<part number>_<index>_<extraction date>*.

A numeric index is used in conjunction with the part number for the component name when multiple operating bias conditions for the part have been supplied by the vendor. The indices correspond to the operating bias condition documented in the descriptive text of the dialog box when this library group is selected from the library list.

Microwave Technology S-Parameters

For modeling specifications, see [“Schematic Design” on page 1-2](#).

The 27 components installed in the library group originate from the Microwave Technology GaAs Fet S-parameter and Hybrid Gain Module Library V1.6 data disk. The data files associated with the components contain linear 2-port S-parameter data and, when provided by the vendor, 2-port noise parameters. The naming convention for the components is *sp_mwt_<part number>_<index>_<extraction date>*.

A numeric index is used in conjunction with the part number for the component name when multiple operating bias conditions for the part have been supplied by the vendor. The indices correspond to the operating bias condition documented in the descriptive text of the dialog box when this library group is selected from the library list.

Mitsubishi S-Parameters

For modeling specifications, see [“Schematic Design” on page 1-2](#).

The 22 components installed in the library group are supplied by the vendor. The data files associated with the components contain linear 2-port S-parameter data and, when provided by the vendor, 2-port noise parameters. The naming convention for the components is *sp_mit_<part number>_<index>_<extraction date>*.

A numeric index is used in conjunction with the part number for the component name when multiple operating bias conditions for the part have been supplied by the vendor. The indices correspond to the operating bias condition documented in the descriptive text of the dialog box when this library group is selected from the library list.

Motorola S-Parameters

For modeling specifications, see [“Schematic Design” on page 1-2](#).

The 626 components files installed in the library group originate from the Motorola Scattering Parameter Library Version 2.0 DK105/D Rev1 data disk. The data files associated with the components contain linear 2-port S-parameter data and, when provided by the vendor, 2-port noise parameters. The naming convention for the components is *sp_mot_<part number>_<index>_<extraction date>*.

A numeric index is used in conjunction with the part number for the component name when multiple operating bias conditions for the part have been supplied by the vendor. The indices correspond to the operating bias condition documented in the

descriptive text of the dialog box when this library group is selected from the library list.

NEC S-Parameters

For modeling specifications, see [“Schematic Design” on page 1-2](#).

The 651 components installed in the library group originate from the CEL Design Parameter Library of NEC Microwave Semiconductor Devices V7.0 data disk. The data files associated with the components contain linear 2-port S-parameter data and, when provided by the vendor, 2-port noise parameters. The naming convention for the components is *sp_nec_<part number>_<index>_<extraction date>*.

A numeric index is used in conjunction with the part number for the component name when multiple operating bias conditions for the part have been supplied by the vendor. The indices correspond to the operating bias condition documented in the descriptive text of the dialog box when this library group is selected from the library list.

Philips S-Parameters

For modeling specifications, see [“Schematic Design” on page 1-2](#).

The 569 components installed in the library group originate from the Philips Noise and S-parameter Library (V1.0) data disk. The data files associated with the components contain linear 2-port S-parameter data and, when provided by the vendor, 2-port noise parameters. The naming convention for the components is *sp_phl_<part number>_<index>_<extraction date>*.

A numeric index is used in conjunction with the part number for the component name when multiple operating bias conditions for the part have been supplied by the vendor. The indices correspond to the operating bias condition documented in the descriptive text of the dialog box when this library group is selected from the library list.

Raytheon S-Parameters

For modeling specifications, see [“Schematic Design” on page 1-2](#).

The 18 components installed in the library group are supplied by the vendor. The data files associated with the components contain linear 2-port S-parameter data

and, when provided by the vendor, 2-port noise parameters. The naming convention for the components is *sp_ray_<part number>_<index>_<extraction date>*.

A numeric index is used in conjunction with the part number for the component name when multiple operating bias conditions for the part have been supplied by the vendor. The indices correspond to the operating bias condition documented in the descriptive text of the dialog box when this library group is selected from the library list.

Siemens S-Parameters

For modeling specifications, see [“Schematic Design” on page 1-2](#).

The 1645 components installed in the library group originate from the Siemens RF Device transistor library V2.0 data disk. The data files associated with the components contain linear 2-port or 1-port S-parameter data and, when provided by the vendor, 2-port noise parameters. The naming convention for the components is *sp_sms_<part number>_<index>_<extraction date>*.

A numeric index is used in conjunction with the part number for the component name when multiple operating bias conditions for the part have been supplied by the vendor. The indices correspond to the operating bias condition documented in the descriptive text of the dialog box when this library group is selected from the library list.

Sony S-Parameters

For modeling specifications, see [“Schematic Design” on page 1-2](#).

The 5 components installed in the library group are supplied by the vendor. The data files associated with the components contain linear 2-port S-parameter data and, when provided by the vendor, 2-port noise parameters. The naming convention for the components is *sp_sny_<part number>_<index>_<extraction date>*.

A numeric index is used in conjunction with the part number for the component name when multiple operating bias conditions for the part have been supplied by the vendor. The indices correspond to the operating bias condition documented in the descriptive text of the dialog box when this library group is selected from the library list.

Toshiba S-Parameters

For modeling specifications, see [“Schematic Design” on page 1-2](#).

The 17 components installed in the library group are supplied by the vendor. The data files associated with the components contain linear 2-port S-parameter data and, when provided by the vendor, 2-port noise parameters. The naming convention for the components is *sp_tsb_<part number>_<index>_<extraction date>*.

A numeric index is used in conjunction with the part number for the component name when multiple operating bias conditions for the part have been supplied by the vendor. The indices correspond to the operating bias condition documented in the descriptive text of the dialog box when this library group is selected from the library list.

Index

S

S-parameter transistors, 1-1

