



ADS 2008
January 2008
3GPP FDD Wireless Test Benches

Advanced Design System 2008

© Agilent Technologies, Inc. 2000-2008

395 Page Mill Road, Palo Alto, CA 94304 U.S.A.

No part of this manual may be reproduced in any form or by any means (including electronic storage and retrieval or translation into a foreign language) without prior agreement and written consent from Agilent Technologies, Inc. as governed by United States and international copyright laws.

Acknowledgments

Mentor Graphics is a trademark of Mentor Graphics Corporation in the U.S. and other countries. Microsoft®, Windows®, MS Windows®, Windows NT®, and MS-DOS® are U.S. registered trademarks of Microsoft Corporation. Pentium® is a U.S. registered trademark of Intel Corporation. PostScript® and Acrobat® are trademarks of Adobe Systems Incorporated. UNIX® is a registered trademark of the Open Group. Java™ is a U.S. trademark of Sun Microsystems, Inc. SystemC® is a registered trademark of Open SystemC Initiative, Inc. in the United States and other countries and is used with permission. MATLAB® is a U.S. registered trademark of The Math Works, Inc.. HiSIM2 source code, and all copyrights, trade secrets or other intellectual property rights in and to the source code in its entirety, is owned by Hiroshima University and STARC.

Errata The ADS product may contain references to "HP" or "HPEESOF" such as in file names and directory names. The business entity formerly known as "HP EEsof" is now part of Agilent Technologies and is known as "Agilent EEsof". To avoid broken functionality and to maintain backward compatibility for our customers, we did not change all the names and labels that contain "HP" or "HPEESOF" references.

Warranty The material contained in this document is provided "as is", and is subject to being changed, without notice, in future editions. Further, to the maximum extent permitted by applicable law, Agilent disclaims all warranties, either express or implied, with regard to this manual and any information contained herein, including but not limited to the implied warranties of merchantability and fitness for a particular purpose. Agilent shall not be liable for errors or for incidental or consequential damages in connection with the furnishing, use, or performance of this document or of any information contained herein. Should Agilent and the user have a separate written agreement with warranty terms covering the material in this document that conflict with these terms, the warranty terms in the separate agreement shall control.

Technology Licenses The hardware and/or software described in this document are furnished under a license and may be used or copied only in accordance with the terms of such license. Portions of this product include the SystemC software licensed under Open Source terms, which are available for download at <http://systemc.org/>. This software is redistributed by Agilent. The Contributors of the SystemC software provide this software "as is" and offer no warranty of any kind, express or implied, including without limitation warranties or conditions or title and non-infringement, and implied warranties or conditions merchantability and fitness for a particular purpose. Contributors shall not be liable for any damages of any kind including without limitation direct, indirect, special, incidental and consequential damages, such as lost profits. Any provisions that differ from this disclaimer are offered by Agilent only.

Restricted Rights Legend If software is for use in the performance of a U.S. Government prime contract or subcontract, Software is delivered and licensed as "Commercial computer software" as defined in DFAR 252.227-7014 (June 1995), or as a "commercial item" as defined in FAR 2.101(a) or as "Restricted computer software" as defined in FAR 52.227-19 (June 1987) or any equivalent agency regulation or contract clause. Use, duplication or disclosure of Software is subject to Agilent Technologies' standard commercial license terms, and non-DOD Departments and Agencies of the U.S. Government will receive no greater than Restricted Rights as defined in FAR 52.227-19(c)(1-2) (June 1987). U.S. Government users will receive no greater than Limited Rights as defined in FAR 52.227-14 (June 1987) or DFAR 252.227-7015 (b)(2) (November 1995), as applicable in any technical data.

Contents

- 3GPP FDD Base Station Transmitter Test
 - ◦ Test Bench Basics
 - Test Bench Details
 - 3GPPFDD_BS_TX
 - Parameter Settings
 - - Basic Parameters
 - Signal Parameters
 - RF Envelope Measurement Parameters
 - Power Measurement Parameters
 - ACLR Measurement Parameters
 - OBW Measurement Parameters
 - CDP Measurement Parameters
 - PCDE Measurement Parameters
 - EVM Measurement Parameters
 - Signal to ESG Parameters
 - Simulation Measurement Displays
 - - RF Envelope Measurement
 - Power Measurement
 - ACLR Measurement
 - Occupied Bandwidth Measurement
 - CDP Measurement
 - PCDE Measurement
 - EVM Measurement
 - Test Bench Variables for Data Displays
 - Baseline Performance
 - - Expected ADS Performance
 - References
- 3GPP FDD User Equipment Transmitter Test
 - ◦ Test Bench Basics
 - Test Bench Details
 - 3GPPFDD_UE_TX
 - Parameter Settings
 - - Basic Parameters
 - Signal Parameters
 - RF Envelope Parameters
 - Power Measurement Parameters
 - ACLR Measurement Parameters
 - ACLR due to Switching Transient Measurement Parameters
 - OBW Measurement Parameters
 - CDP Measurement Parameters
 - PCDE Measurement Parameters
 - EVM Parameters
 - Signal to ESG Parameters
 - Simulation Measurement Displays
 - - RF Envelope Measurement
 - Power Measurement

- ACLR Measurement
 - ACLR Due to Switching Transient Measurement
 - Occupied Bandwidth Measurement
 - CDP Measurement
 - PCDE Measurement
 - EVM Measurement
 - Test Bench Variables for Data Displays
- Baseline Performance
- - Expected ADS Performance
- References
- 3GPP FDD Base Station Receiver Test
- ◦ Test Bench Basics
- Test Bench Details
- 3GPPFDD_BS_RX
- Parameter Settings
- - Basic Parameters
- - Signal Parameters
- - RefLevel Parameters
- - DynamicRange Parameters
- - ACS Parameters
- - Blocking Parameters
- - Intermod Parameters
- - Measurement Parameters
- Simulation Measurement Displays
- - Reference Sensitivity Level
- - Dynamic Range
- - Adjacent Channel Selectivity
- - Blocking Characteristics
- - Intermodulation Characteristics
- - Test Bench Variables for Data Displays
- Baseline Performance
- - Expected ADS Performance
- References
- 3GPP FDD User Equipment Receiver Test
- ◦ Test Bench Basics
- Test Bench Details
- 3GPPFDD_UE_RX
- Parameter Settings
- - Basic Parameters
- - Signal Parameters
- - RefLevel Parameters
- - MaxLevel Parameters
- - ACS Parameters
- - Blocking Parameters
- - Intermod Parameters
- - Measurement Parameters
- Simulation Measurement Displays
- - Reference Sensitivity Level
- - Maximum Input Level
- - Adjacent Channel Selectivity

- Blocking Characteristics
- Intermodulation Characteristics
- Test Bench Variables for Data Displays
- Baseline Performance
 - - Expected ADS Performance
- References
- RF DUT Limitations for 3GPP FDD Wireless Test Benches
- Measurement Results for Expressions for 3GPP FDD Wireless Test Benches

3GPP FDD Base Station Transmitter Test

3GPPFDD_BS_TX is the test bench for 3GPP FDD base station transmitter testing. The test bench provides a way for users to connect to an RF circuit device under test and determine its performance by activating various test bench measurements. This test bench provides signal measurements for RF envelope, power (including CCDF), occupied bandwidth, ACLR, code and peak code domain power, and EVM.

The signal and most of the measurements are designed according to the 3GPP Technical Specification TS 25.141 and TS 25.104. Versions supported are 2000-03, 2000-12, and 2002-03.

This 3GPP FDD signal model is compatible with Agilent E4438C ESG Vector Signal Generator, Option 400 (3GPP W-CDMA Firmware Option for the E4438C ESG Vector Signal Generator). Details regarding Agilent E4438C ESG are included at the website <http://www.agilent.com/find/esg>.

The DUT output signal can be sent to an Agilent ESG RF signal generator.

This test bench includes a DSP section, an RF modulator, RF output source resistance, RF DUT connection, RF receivers, and DSP measurement blocks, as illustrated in the following figure. The generated test signal is sent to the DUT.

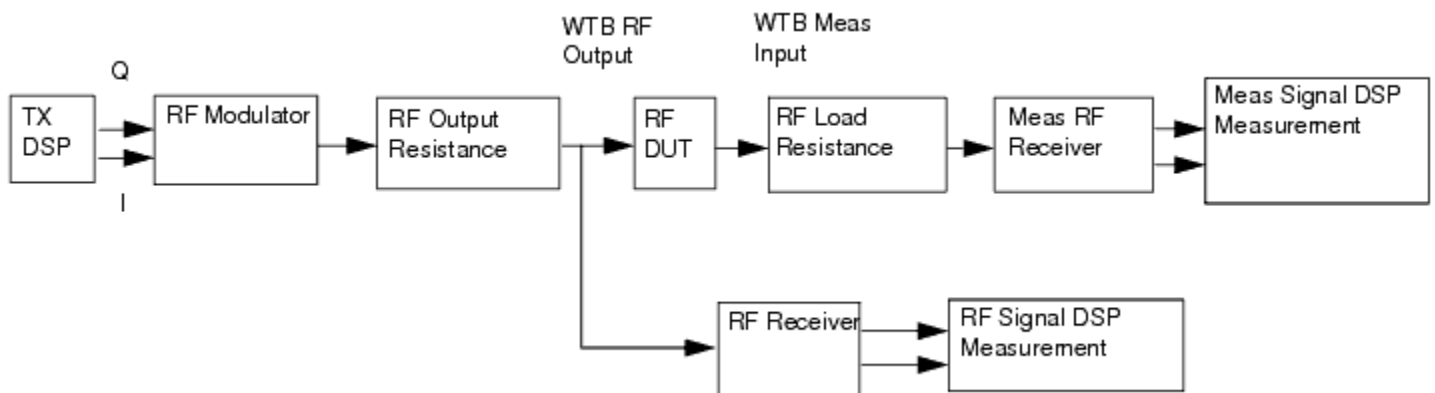

Transmitter Wireless Test Bench Block Diagram

In the 3GPP downlink signal frame structure, one frame has a duration of 10 msec and consists of 15 slots; each slot contains 2560 chips; each chip is an RF signal symbol.

There is only one type of downlink dedicated physical channel, the downlink dedicated physical channel (downlink DPCH). Within one downlink DPCH, dedicated data generated at Layer 2 and above (i.e. the dedicated transport channel (DCH), is transmitted in time-multiplex with control information generated at Layer 1). Layer 1 control information consists of known pilot bits to support channel estimation for coherent detection, transmit power-control (TPC) commands, and an optional transport-format combination indicator (TFCI). The TFCI informs the receiver about the instantaneous transport format combination of the transport channels mapped to the simultaneously transmitted downlink DPCH radio frame.

The downlink DPCH can therefore be seen as a time multiplex of a downlink DPDCH (Data1 and Data2) and a downlink DPCCH (TPC, TFCI, and Pilot).

The frame and slot structure of the downlink DPCH is illustrated in the following figure. (The following tables provide more information about each field.)

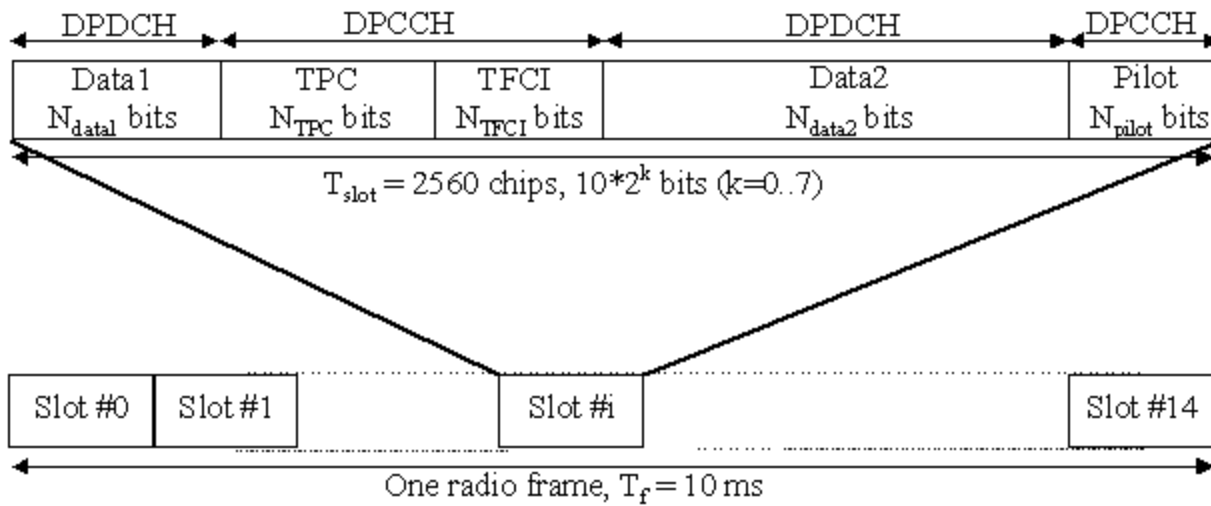

3GPP FDD Downlink Frame and Slot Structure

DPCH Structure for Test Model 1 and Test Model 2

Slot Format No.	Channel Bit Rate (kbps)	Channel Symbol Rate (kbps)	SF	Bits/Slot	DPDCH Bits/Slot		DPCCH Bits/Slot		
					NData1	NData2	NTFCI	NTPC	Npilot
10	60	30	128	40	6	24	0	2	8

DPCH Structure for Test Model 3

Slot Format No.	Channel Bit Rate (kbps)	Channel Symbol Rate (kbps)	SF	Bits/Slot	DPDCH Bits/Slot		DPCCH Bits/Slot		
					NData1	NData2	NTFCI	NTPC	Npilot
6	30	15	256	20	2	8	0	2	8

Test Bench Basics

A template is provided for this test bench.

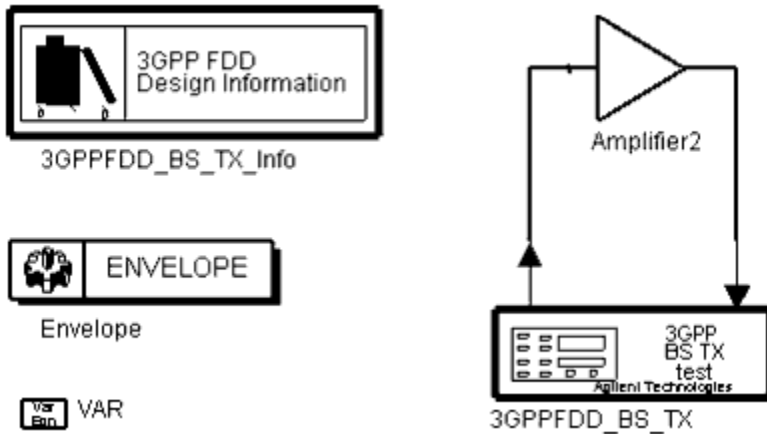

3GPPFDD Base Station Transmitter Test Bench

To access the template:

1. In an Analog/RF schematic window select Insert > Template.
2. In the Insert > Template dialog box, choose 3GPPFDD_BS_TX_test, click OK; click left to place the template in the schematic window.

An example design using this template is available; from the ADS Main window click File > Example Project > WCDMA3G_RF_Verification_prj > 3GPPFDD_BS_TX_test .dsn.

The basics for using the test bench are:

- Connect to an RF DUT that is suitable for this test bench.
- CE_TimeStep, FSource, SourcePower, and FMeasurement parameter default values are typically accepted; if not, set values based on your requirements.
- Activate/deactivate measurement(s) based on your requirements.
- Run the simulation and view Data Display page(s) for your measurement(s).

For details, refer to [Test Bench Details](#).

Test Bench Details

The following sections provide details for setting up a test bench, setting measurement parameters for more control of the test bench, simulation measurement displays, and baseline performance.

Open and use the template:

1. In an Analog/RF schematic window select Insert > Template .
2. In the Insert > Template dialog box, choose 3GPPFDD_BS_TX_test, click OK; click left to place the template in the schematic window.

Test bench setup is detailed here.

1. Replace the DUT (Amplifier2 is provided with this template) with an RF DUT that is suitable for this test bench. For information regarding using certain types of DUTs, see Appendix A, RF DUT Limitations.
2. Set the Required Parameters



Note

Refer to [3GPPFDD_BS_TX](#) for a complete list of parameters for this test bench.

Generally, default values can be accepted; otherwise, values can be changed by the user as needed.

- Set CE_TimeStep.
Cosimulation occurs between the test bench (using Agilent ADS Ptolemy Data Flow simulation technology) and the DUT (using Circuit Envelope simulation technology). Each technology requires its own simulation time step with time-step coordination occurring in the interface between the technologies. CE_TimeStep defines the Circuit Envelope simulation time step to be used with this DUT. The CE_TimeStep must be set to a value equal to or a submultiple of (less than) WTB_TimeStep; otherwise, simulation will stop and an error message will be displayed.
Note that WTB_TimeStep is not user-settable. Its value is derived from other test bench parameter values;

Advanced Design System 2008

with default settings $WTB_TimeStep = \text{approx. } 32.6 \text{ nsec}$. The value is displayed in the Data Display pages as $TimeStep$.

$$WTB_TimeStep = 1 / (\text{ChipRate} \times \text{SamplesPerChip})$$

where

$ChipRate$ is the non-settable value (3.84 MHz)

$SamplesPerChip$ is the number of waveform sampling points during pulse forming.

- Set $FSource$, $SourcePower$, and $FMeasurement$.
 - $FSource$ defines the RF frequency for the signal input to the RF DUT.
 - $SourcePower$ defines the power level for $FSource$. $SourcePower$ is defined as the average power during the non-idle time of the signal.
 - $FMeasurement$ defines the RF frequency output from the DUT to be measured.
- 3. Activate/deactivate (YES / NO) test bench measurements (refer to [3GPPFDD BS TX](#)). At least one measurement must be enabled.
- 4. More control of the test bench can be achieved by setting Basic Parameters, Signal Parameters, and parameters for each activated measurement. For details refer to [Parameter Settings](#).
- 5. The RF modulator (shown in the block diagram in [Transmitter Wireless Test Bench Block Diagram](#)) uses $FSource$, $SourcePower$ (Required Parameters), $MirrorSourceSpectrum$ (Basic Parameters), $GainImbalance$, $PhaseImbalance$, I OriginOffset, Q OriginOffset, and IQ Rotation (Signal Parameters).
The RF output resistance uses $SourceR$, $SourceTemp$, and $EnableSourceNoise$ (Basic Parameters). The RF output signal source has a 50-ohm (default) output resistance defined by $SourceR$.
RF output (and input to the RF DUT) is at the frequency specified ($FSource$), with the specified source resistance ($SourceR$) and with power ($SourcePower$) delivered into a matched load of resistance $SourceR$. The RF signal has additive Gaussian noise power set by resistor temperature ($SourceTemp$) (when $EnableSourceNoise=YES$).
Note that the $Meas_in$ point of the test bench provides a resistive load to the RF DUT set by the $MeasR$ value (50-ohm default) (Basic Parameters).
The $Meas$ signal contains linear and nonlinear signal distortions and time delays associated with the RF DUT input to output characteristics.
The TX DSP block (shown in the block diagram in [Transmitter Wireless Test Bench Block Diagram](#)) uses other Signal Parameters.
- 6. More control of Circuit Envelope analysis can be achieved by setting Envelope controller parameters. These settings include $EnableFastCosim$, which may speed the RF DUT simulation more than 10×. Setting these simulation options is described in [Setting Fast Cosimulation Parameters](#) and [Setting Circuit Envelope Analysis Parameters](#) in the [Wireless Test Bench Simulation](#) documentation.
- 7. To send the RF DUT output signal to an Agilent ESG RF signal generator, set parameters on the Signal to ESG tab.
For details, refer to [Signal to ESG Parameters](#).
- 8. To run a simulation, choose Simulation > Run in the Analog Design Environment main window.
For details, refer to [Running a Simulation in the Wireless Test Bench Simulation](#) documentation.
- 9. Simulation results will appear in a Data Display window for each measurement. [Simulation Measurement Displays](#) describes results for each measurement.
For details on Viewing Results refer to the [Wireless Test Bench Simulation](#) documentation.

3GPPFDD_BS_TX

This section provides parameter information for Required Parameters, Basic Parameters, Signal Parameters, and parameters for the various measurements.



Description 3GPP FDD BS TX test
 Library WTB
 Class TSDF3GPPFDD_BS_TX
 Derived From baseWTB_TX

Parameters

Name	Description	Default	Sym	Unit	Type	Range
RequiredParameters						
CE_TimeStep	Circuit envelope simulation time step	1/3.84 MHz/8		sec	real	(0, ∞)
WTB_TimeStep	Set CE_TimeStep < = 1/3.84e6/SamplesPerChip. SamplesPerChip is in Signal Parameters tab.					
FSource	Source carrier frequency	2140 MHz		Hz	real	(0, ∞)
SourcePower	Source power	dbmtow(-20.0)		W	real	[0, ∞)
FMeasurement	Measurement carrier	2140 MHz		Hz	real	(0, ∞)

Advanced Design System 2008

	frequency					
MeasurementInfo	Available Measurements Each measurement has parameters on its tab/category below.					
RF_EnvelopeMeasurement	Enable RF envelope measurement? NO, YES	YES			enum	
PowerMeasurement	Enable power measurement? NO, YES	NO			enum	
ACLR_Measurement	Enable ACLR measurement? NO, YES	NO			enum	
OccupiedBW_Measurement	Enable occupied bandwidth measurement? NO, YES	NO			enum	
CDP_Measurement	Enable code domain power measurement? NO, YES	NO			enum	
PCDE_Measurement	Enable peak code domain error measurement? NO, YES	NO			enum	
EVM_Measurement	Enable EVM measurement? NO, YES	NO			enum	
BasicParameters						
SourceR	Source resistance	50 Ohm		Ohm	real	(0, ∞)
SourceTemp	Source resistor temperature	-273.15		Celsius	real	[-273.15, ∞)

Advanced Design System 2008

EnableSourceNoise	Enable source thermal noise? NO, YES	NO			enum	
MeasR	Measurement resistance	50 Ohm		Ohm	real	[10, 1.0e6]
MirrorSourceSpec	Mirror source spectrum about carrier? NO, YES	NO			enum	
MirrorMeasSpec	Mirror meas spectrum about carrier? NO, YES	NO			enum	
RF_MirrorFreq	Mirror source frequency for spectrum/envelope measurement? NO, YES	NO			enum	
MeasMirrorFreq	Mirror meas frequency for spectrum/envelope measurement? NO, YES	NO			enum	
DUT_DelayBound	DUT delay bound	10.0 usec		sec	real	[0, (400.0/3840000)]
TestBenchSeed	Random number generator seed	1234567			int	[0, ∞)
SignalParameters						
GainImbalance	Gain imbalance, Q vs I	0.0		dB	real	(-∞, ∞)
PhaseImbalance	Phase imbalance, Q vs I	0.0		deg	real	(-∞, ∞)
I_OriginOffset	I origin offset (percent)	0.0			real	(-∞, ∞)
Q_OriginOffset	Q origin offset (percent)	0.0			real	(-∞, ∞)
IQ_Rotation	IQ rotation	0.0		deg	real	(-∞, ∞)

Advanced Design System 2008

SamplesPerChip	Samples per chip	8	S		int	[2, 32]
RRC_FilterLength	RRC filter length (chips)	16			int	[1, ∞)
SpecVersion	Secification version: Version 03_00, Version 12_00, Version 03_02	Version 12_00			enum	
SourceType	Source type: TestModel1_16DPCHs, TestModel1_32DPCHs, TestModel1_64DPCHs, TestModel2, TestModel3_16DPCHs, TestModel3_32DPCHs, TestModel4	TestModel1_16DPCHs			enum	
RF_EnvelopeMeasurementParameters						
RF_EnvelopeDisplayPages	RF Envelope measurement display pages: 3GPPFDD_BS_TX Envelope Figures					
RF_EnvelopeStart	RF envelope measurement start	0.0		sec	real	[0, ∞)
RF_EnvelopeStop	RF envelope measurement stop	(2560/3.84) usec		sec	real	(0, ∞)
RF_EnvelopeSlots	RF envelope measurement slots	1			int	[0, 100]
PowerMeasurementParameters						
PowerDisplayPages	Power measurement display pages: 3GPPFDD_BS_TX Power Tables 3GPPFDD_BS_TX Power Figures 3GPPFDD_BS_TX					

Advanced Design System 2008

	Power Equations					
PowerStartSlot	Start slot	0			int	[0, ∞)
PowerSlotsMeasured	Slots measured	1			int	[0, ∞)
ACLR_MeasurementParameters						
ACLR_DisplayPages	ACLR measurement display pages: 3GPPFDD_BS_TX ACLR Tables 3GPPFDD_BS_TX ACLR Figures 3GPPFDD_BS_TX ACLR Equations					
ACLR_Start	Measurement start	0.0		sec	real	[0, ∞)
ACLR_Stop	Measurement stop	(2560/3.84) usec		sec	real	(0, ∞)
ACLR_Slots	Measurement slots	0			int	[0, 100]
ACLR_SpecMeasurement	SpBW resolution bandwidth	0		Hz	real	[0, ∞)
ACLR_SpecMeasurementWindow	Window type: ACLR none, ACLR Hamming 0.54, ACLR Hanning 0.50, ACLR Gaussian 0.75, ACLR Kaiser 7.865, ACLR 8510 6.0, ACLR Blackman, ACLR Blackman-Harris	ACLR none			enum	
OccupiedBW_MeasurementParameters						
OBW_DisplayPages	Occupied BW measurement display pages:					

Advanced Design System 2008

	3GPPFDD_BS_TX OBW Tables 3GPPFDD_BS_TX OBW Figures 3GPPFDD_BS_TX OBW Equations					
OBW_Start	Measurement start	0.0		sec	real	[0, ∞)
OBW_Stop	Measurement stop	(2560/3.84) usec		sec	real	(0, ∞)
OBW_Slots	Measurement slots	0			int	[0, 100]
OBW_SpecMeasure	Resolution bandwidth	0		Hz	real	[0, ∞)
OBW_SpecMeasure	Window type: OBW none, OBW Hamming 0.54, OBW Hanning 0.50, OBW Gaussian 0.75, OBW Kaiser 7.865, OBW 8510 6.0, OBW Blackman, OBW Blackman-Harris	OBW none			enum	
CDP_MeasurementParameters						
CDP_DisplayPages	CDP measurement display pages: 3GPPFDD_BS_TX CDP Figures					
CDP_StartSlot	Start slot	0			int	[0, ∞)
PCDE_MeasurementParameters						
PCDE_DisplayPages	PCDE measurement display pages: 3GPPFDD_BS_TX PCDE Tables 3GPPFDD_BS_TX					

Advanced Design System 2008

	PCDE Figures 3GPPFDD_BS_TX PCDE Equations					
PCDE_StartSlot	Start slot	0			int	[0, ∞)
EVM_MeasurementParameters						
EVM_DisplayPages	EVM measurement display pages: 3GPPFDD_BS_TX EVM Tables 3GPPFDD_BS_TX EVM Equations					
EVM_Start	Measurement start	0.0		sec	real	[0, ∞)
EVM_SlotsMeasured	Slots measured	1			int	[1, ∞)
SignalToESG_Parameters						
EnableESG	Enable signal to ESG? NO, YES	NO			enum	
ESG_Instrument	ESG instrument address	[GPIB0::19::INSTR][localhost][4790]			instrument	
ESG_Start	Signal start	0		sec	real	[0, ∞)
ESG_Stop	Signal stop	(2560/3.84) usec		sec	real	[(ESG_Start+60/3.84e6 (ESG_Start+32/3.84/S)
ESG_Slots	Slots to ESG	15			int	[0, 1000]
ESG_Power	ESG RF ouput power (dBm)	-20.0			real	(-∞, ∞)
ESG_ClkRef	Waveform clock reference: Internal, External	Internal			enum	
ESG_ExtClkRefFreq	External clock reference freq	10 MHz		Hz	real	(0, ∞)
ESG_IQFilter	IQ filter: through, filter_2100kHz, filter_40MHz	through			enum	

Advanced Design System 2008

ESG_SampleClockRate	Sequencer sample clock rate	30.72 MHz		Hz	real	(0, ∞)
ESG_Filename	ESG waveform storage filename	3GPPFDD_DL			string	
ESG_AutoScaling	Activate auto scaling? NO, YES	YES			enum	
ESG_ArbOn	Select waveform and turn ArbOn after download? NO, YES	YES			enum	
ESG_RFPowOn	Turn RF ON after download? NO, YES	YES			enum	
ESG_EventMarkerType	Event marker type: Neither, Event1, Event2, Both	Event1			enum	
ESG_MarkerLength	ESG marker length	10			int	[1, 60]

Pin Inputs

Pin	Name	Description	Signal Type
2	Meas_In	Test bench measurement RF input from RF circuit	timed

Pin Outputs

Pin	Name	Description	Signal Type
1	RF_Out	Test bench RF output to RF circuit	timed

Parameter Settings

More control of the test bench can be achieved by setting parameters on the Basic Parameters, Signal Parameters, and measurements categories for the activated measurements. Parameters for each category are described in the following sections.



Note

For required parameter information, see [Set the Required Parameters](#).

Basic Parameters

1. SourceR is the RF output source resistance.
2. SourceTemp is the RF output source resistance temperature (oC) and sets noise density in the RF output signal to $(k(\text{SourceTemp}+273.15))$ Watts/Hz, where k is Boltzmann's constant.
3. EnableSourceNoise, when set to NO disables the SourceTemp and effectively sets it to -273.15oC (0 Kelvin). When set to YES, the noise density due to SourceTemp is enabled.
4. MeasR defines the load resistance for the RF DUT output Meas signal into the test bench. This resistance loads the RF DUT output; it is also the reference resistance for Meas signal power measurements.
5. MirrorSourceSpectrum is used to invert the polarity of the Q envelope of the generated RF signal before it is sent to the RF DUT. Depending on the configuration and number of mixers in an RF transmitter, the signal at the input of the DUT may need to be mirrored. If such an RF signal is desired, set this parameter to YES.
6. MirrorMeasSpectrum is used to invert the polarity of the Q envelope in the Meas_in RF signal input to the test bench (and output from the RF DUT). Depending on the configuration and number of mixers in the RF DUT, the signal at its output may be mirrored compared to the signal generated by the signal source (before any mirroring is done because of the MirrorSourceSpectrum setting). Proper demodulation and measurement of the RF DUT output signal requires that its RF envelope is not mirrored compared to the signal generated by the signal source (before any mirroring is done because of the MirrorSourceSpectrum setting). If the Meas_in RF signal is mirrored, set this parameter to YES. Proper setting of this parameter is required for measurements on the Meas_in signal in TX test benches (EVM, Constellation, CDP, PCDE) and results in measurement on a signal with no spectrum mirroring.
7. TestBenchSeed is an integer used to seed the random number generator used with the test bench. This value is used by all test bench random number generators, except those RF DUT components that use their own specific seed parameter. TestBenchSeed initializes the random number generation. The same seed value produces the same random results, thereby giving you predictable simulation results. To generate repeatable random output from simulation to simulation, use any positive seed value. If you want the output to be truly random, enter the seed value of 0.
8. RF_MirrorFreq is used to invert the polarity of the Q envelope in the RF_out RF signal for RF envelope, ppectrum, ACLR, and occupied bandwidth measurements. RF_MirrorFreq is typically set by the user to NO when MirrorSourceSpectrum = NO; RF_MirrorFreq is typically set by the user to YES when MirrorSourceSpectrum = YES. Both settings result in viewing the RF_out signal with no spectrum mirroring. Other settings by the user result in RF_out signal for RF_Envelope and Spectrum measurements with spectrum mirroring.
9. MeasMirrorFreq is used to invert the polarity of the Q envelope in the Meas_in RF signal for the RF envelope, spectrum, ACLR, and occupied bandwidth measurements. MeasMirrorFreq is typically set to NO by the user when the combination of the MirrorSourceSpectrum value and any signal mirroring in the users RF DUT results in no spectrum mirroring in the Meas_in signal. MeasMirrorFreq is typically set to YES by the user when the combination of the MirrorSourceSpectrum and RF DUT results in spectrum mirroring in the Meas_in signal. Other settings result in Meas_in signal for RF_Envelope and Spectrum measurements with spectrum mirroring.

The MirrorMeasSpectrum parameter setting has no impact on the setting or use of the MeasMirrorFreq parameter.

10. DUT_DelayBound is used to transfer the DUT delay to measurements synchronization. For measurements of RF_out before the DUT, an RF delay bound is calculated by adding delays caused by RRC filters in modulation and measurements. For measurements of RF DUT output (Meas_in), Meas delay bound is calculated by adding DUT_DelayBound to RF delay bound.

Signal Parameters

1. GainImbalance, PhaseImbalance, I_OriginOffset, Q_OriginOffset, and IQ_Rotation are used to add certain impairments to the ideal output RF signal. Impairments are added in the order described here. The unimpaired RF I and Q envelope voltages have gain and phase imbalance applied. The RF is given by:

$$V_{RF}(t) = A \left(V_I(t) \cos(\omega_c t) - g V_Q(t) \sin\left(\omega_c t + \frac{\phi\pi}{180}\right) \right)$$

where A is a scaling factor that depends on the SourcePower and SourceR parameters specified by the user, $V_I(t)$ is the in-phase RF envelope, $V_Q(t)$ is the quadrature phase RF envelope, g is the gain imbalance

$$g = 10^{\frac{\text{GainImbalance}}{20}}$$

and, ϕ (in degrees) is the phase imbalance.

Next, the signal $V_{RF}(t)$ is rotated by IQ_Rotation degrees. The I_OriginOffset and Q_OriginOffset are then applied to the rotated signal. Note that the amounts specified are percentages with respect to the output rms voltage. The output rms voltage is given by $\sqrt{2 \times \text{SourceR} \times \text{SourcePower}}$.

2. SamplesPerChip is used to set the number of samples in a chip. The default value is set to 8 to display settings according to the 3GPP standard. It can be set to a larger value for a simulation frequency bandwidth wider than 8×3.84 MHz. It can be set to a smaller value for faster simulation; however, this will result in lower signal fidelity. If SamplesPerChip = 8, the simulation RF bandwidth is larger than the signal bandwidth by a factor of 8 (e.g., simulation RF bandwidth = 8×3.84 MHz).
3. RRC_FilterLength is used to set root raised-cosine (RRC) filter length in number of chips. The default value is set to 16 to transmit a 3GPP FDD downlink signal in time and frequency domains based on the 3GPP standard [4]. It can be set to a smaller value for faster simulation times; however, this will result in lower signal fidelity. Better Adjacent Channel Leakage Ratio (ACLR) can be obtained using a longer filter length. Increasing RRC_FilterLength to 24 or 32 should result in a better ACLR. This may also correlate better to ACLR measurements when using instruments from Agilent Technologies.
4. SpecVersion is used to specify the 3GPP specification versions (2000-03, 2000-12 and 2002-03).
5. SourceType is used to specify the type of baseband signal. This source can generate 7 types of baseband signals [5]: TestModel1_16DPCHs, TestModel1_32DPCHs, TestModel1_64DPCHs, TestModel2, TestModel3_16DPCHs, TestModel3_32DPCHs, and TestModel4

Advanced Design System 2008

- [Test Model 1 Active Channels](#) lists the active channels of Test Model 1, which is used to test spectrum emission mask, ACLR, spurious emissions, transmit intermodulation, and base station maximum output power.
- [Test Model 2 Active Channels](#) lists the active channels in Test Model 2, which is used to test output power dynamics.
- [Test Model 3 Active Channels](#) lists the active channels of Test Model 3, which is used to test peak code domain error.
- [Test Model 4 Active Channels](#) lists the active channels of Test Model 4, which is used to test EVM.

Test Model 1 Active Channels

Type	Number of Channels	Fraction of Power (%)	Level Setting (dB)	Channelization Code	Timing Offset (x256Tchip)
PCCPCH+SCH	1	10	-10	1	0
Primary CPICH	1	10	-10	0	0
PICH	1	1.6	-18	16	120
SCCPCH containing PCH (SF=256) [†]	1	1.6	-18	3	0
DPCH (SF=128)	16/32/64	76.8 total	see [5]	see [5]	see [5]

[†] SCCPCH containing PCH is not included in versions 2000-03 and 2000-12 [5].

Test Model 2 Active Channels

Type	Number of Channels	Fraction of Power (%)	Level Setting (dB)	Channelization Code	Timing Offset (x256Tchip)
PCCPCH+SCH	1	10	-10	1	0
Primary CPICH	1	10	-10	0	0
PICH	1	5	-13	16	120
S-CCPCH containing PCH (SF=256)	1	5	-13	3	0
DPCH (SF=128)	3	2 x 10, 1 x 50	2 x -10, 1 x -3	24, 72, 120	1, 7, 2

[†] SCCPCH containing PCH is not included in versions 2000-03 and +2000-12+[5]

Test Model 3 Active Channels

Type	Number of	Fraction of Power	Level Settings	Channelization	Timing Offset
------	-----------	-------------------	----------------	----------------	---------------

Advanced Design System 2008

	Channels	(%) 16/32	(dB) 16/32	Code	(x256Tchip)
PCCPCH+SCH	1	12.6/7.9	-9 / -11	1	0
Primary CPICH	1	12.6/7.9	-9 / -11	0	0
PICH	1	5/1.6	-13 / -18	16	120
SCCPCH containing PCH (SF=256) †	1	5/1.6	-13 / -18	3	0
DPCH (SF=256)	16/32	63,7/80,4 total	see Reference [5]	see Reference [5]	see Reference [5]

† SCCPCH containing PCH is not included in versions 2000-03 and 2000-12 [5]

Test Model 4 Active Channels

Type	Number of Channels	Fraction of Power (%) 16/32	Level Settings (dB) 16/32	Channelization Code	Timing Offset (x256Tchip)
PCCPCH+SCH when Primary CPICH is disabled	1	50 to 1.6	-3 to -18	1	0
PCCPCH+SCH when Primary CPICH is enabled	1	25 to 0.8	-6 to -21	1	0
Primary CPICH†	1	25 to 0.8	-6 to -21	0	0

† Primary CPICH is optional; it is not included in versions 2000-03 and 2000-12 [5]

RF Envelope Measurement Parameters

This measurement is not affected by the MirrorMeasSpectrum parameter. To apply spectrum mirroring to the measured RF_out signal, set RF_MirrorFreq = YES. To apply spectrum mirroring to the measured Meas_in signal, set MeasMirrorFreq = YES.

1. RF_EnvelopeDisplayPages provides Data Display page information for this measurement. It cannot be changed by the user.
2. RF_EnvelopeStart sets the start time for collecting input data.
3. RF_EnvelopeStop sets the stop time for collecting input data when RF_EnvelopeSlots = 0.
4. RF_EnvelopeSlots (when > 0) sets the number of slots over which data will be collected.

Depending on the values of RF_EnvelopeStart, RF_EnvelopeStop, and RF_EnvelopeSlots, the stop time may be

adjusted.

For RF envelope measurement for both the RF_out and Meas_in signals:

Let:

$$\text{Start} = \text{TimeStep} \times (\text{int}(\text{RF_EnvelopeStart}/\text{TimeStep}) + 0.5)$$

$$\text{Stop} = \text{TimeStep} \times (\text{int}(\text{RF_EnvelopeStop}/\text{TimeStep}) + 0.5)$$

This means Start and Stop are forced to be an integer number of time-step intervals.

RF_EnvelopeSlots	Resultant Stop Time
0	Stop
> 0	Start + RF_EnvelopeSlots x SlotTime

For the RF envelope of Meas_in to contain at least one complete slot, the Stop value should be set to a minimum of SlotTime + (RF DUT time delay).

For information about TimeStep and SlotTime, see [Test Bench Variables for Data Displays](#).

Power Measurement Parameters

1. PowerDisplayPages provides Data Display page information for this measurement. It cannot be changed by the user.
2. PowerStartSlot sets the number of slots which should be ignored.
3. PowerSlotsMeasured sets the number of slots over which data will be collected.

The measurement start time is PowerStartSlot × SlotTime. The measurement stop time is (PowerStartSlot + PowerSlotsMeasured) × SlotTime. SlotTime is defined in [Test Bench Variables for Data Displays](#).

ACLR Measurement Parameters

The ACLR measurement is implemented by the spectrum measurement, which measures the RF signal spectrum in different frequency offsets. The ACLR can be calculated by analyzing the spectrum measurement in the data display file.

In the following, TimeStep denotes the simulation time step, and FMeasurement denotes the measured RF signal characterization frequency.

1. The measurement outputs the complex amplitude voltage values at the frequencies of the spectral tones. It does

not output power at frequencies of the spectral tones. However, one can calculate and display the power spectrum as well as the magnitude and phase spectrum by using the dBm, mag, and phase functions of the data display window.

Note that the dBm function assumes a 50-ohm reference resistance; if a different measurement was used in the test bench, its value can be specified as a second argument to the dBm function, for example, dBm(SpecMeas, Meas_RefR) where SpecMeas is the instance name of the spectrum measurement and Meas_RefR is the resistive load used.

By default, the displayed spectrum extends from FMeasurement - 1/(2TimeStep) Hz to FMeasurement + 1/(2TimeStep) Hz. When FMeasurement < 1/(2TimeStep), the default spectrum extends to negative frequencies. The spectral content at these negative frequencies is conjugated, mirrored, and added to the spectral content of the closest positive frequency. This way, the negative frequency tones are displayed on the positive frequency axis as would happen in an RF spectrum analyzer measurement instrument. This process may introduce an error in the displayed frequency for the mirrored tones. The absolute error introduced is less than (spectrum frequency step) / 2 (see the following table for the definition of spectrum frequency step).

The basis of the algorithm used by the spectrum measurement is the chirp-Z transform. The algorithm can use multiple slots and average the results to achieve video averaging (see note 6).

2. ACLR_DisplayPages provides Data Display page information for this measurement. It cannot be changed by the user.
3. ACLR_Start sets the start time for collecting input data.
4. ACLR_Stop sets the stop time for collecting input data when ACLR_Slots = 0 and ACLR_SpecMeasResBW = 0.
5. ACLR_Slots (when > 0) sets the number of slots over which data will be collected.
6. ACLR_SpecMeasResBW (when > 0) sets the resolution bandwidth of the spectrum measurement. Depending on the values of ACLR_Stop, ACLR_Slots, and ACLR_SpecMeasResBW, the stop time may be adjusted and/or spectrum video averaging may occur. The different cases are explained in the following table.

Referring to the following table let:

$$\text{Start} = \text{TimeStep} \times \text{int}((\text{ACLR_Start}/\text{TimeStep}) + 0.5)$$

$$\text{Stop} = \text{TimeStep} \times \text{int}((\text{ACLR_Stop}/\text{TimeStep}) + 0.5)$$

(This means Start and Stop are forced to be an integer number of time step intervals.)

X be the Normalized Equivalent Noise BW of the window used

Equivalent noise bandwidth (ENBW) compares the window to an ideal, rectangular filter. It is the equivalent width of a rectangular filter that passes the same amount of white noise as the window. The normalized ENBW is the ENBW multiplied by the time duration of the signal being windowed. See [Window Options and Normalized Equivalent Noise Bandwidth](#) for the normalized ENBW for the different window options available.

The Start and Stop times are used for both the RF_out and Meas_in signal spectrum analyses. The Meas_in signal is delayed in time from the RF_out signal by the value of the RF DUT time delay. Thus for RF DUT time delay > 0, the RF_out and Meas_in signal are inherently different and some spectrum display difference in the two is expected.

TimeStep and SlotTime are defined in Test Bench Variables for Data Displays.

Effect of Different Values for ACLR_Stop, ACLR_Slots, and ACLR_SpecMeasResBW

Case 1	ACLR_Slots = 0 ACLR_SpecMeasResBW = 0 Resultant stop time = Stop Resultant resolution BW = X/(Stop - Start)
--------	--

Advanced Design System 2008

	<p>Resultant spectrum frequency step = $1/(\text{Stop}-\text{Start})$ Video averaging status = None</p>
<p>Case 2</p>	<p>$\text{ACLR_Slots} > 0$ $\text{ACLR_SpecMeasResBW} = 0$ Resultant stop time = $\text{Start} + \text{ACLR_Slots} \times \text{SlotTime}$ Notes: For $\text{ACLR_Slots} > 0$ and $\text{ACLR_SpecMeasResBW} = 0$ Video averaging occurs over all slot time intervals Resultant resolution BW = $X/\text{SlotTime}$ Resultant spectrum frequency step = $1/\text{SlotTime}$ Video averaging status = Yes, when $\text{ACLR_Slots} > 1$</p>
<p>Case 3</p>	<p>$\text{ACLR_Slots} = 0$ $\text{ACLR_SpecMeasResBW} > 0$ Resultant stop time = $\text{Start} + N \times \text{SlotTimeInterval}$ where $N = \text{int}((\text{Stop} - \text{Start})/\text{SlotTimeInterval}) + 1$ For $\text{ACLR_Slots} = 0$ and $\text{ACLR_SpecMeasResBW} > 0$ Define $\text{SlotTimeInterval} = \text{TimeStep} * \text{int}((X/(\text{ACLR_SpecMeasResBW} * \text{TimeStep})) + 0.5)$ This means SlotTimeInterval is forced to a value that is an integer number of time step intervals. (Stop-Start) time is forced to be an integer number (N) of SlotTimeInterval N has a minimum value of 1 Video averaging occurs over all SlotTimeInterval The resolution bandwidth achieved is $\text{ResBW} = X / \text{SlotTimeInterval}$, which is very close to $\text{ACLR_SpecMeasResBW}$ but may not be exactly the same if $X/(\text{ACLR_SpecMeasResBW} * \text{TimeStep})$ is not an exact integer. Resultant resolution BW = ResBW Resultant spectrum frequency step = ResBW Video averaging status = Yes when $N > 1$</p>
<p>Case 4</p>	<p>$\text{ACLR_Slots} > 0$ $\text{ACLR_SpecMeasResBW} > 0$ Resultant stop time = $\text{Start} + M \times \text{SlotTimeInterval}$ where $M = \text{int}((\text{ACLR_Slots} \times \text{SlotTime})/\text{SlotTimeInterval}) + 1$ For $\text{ACLR_Slots} > 0$ and $\text{ACLR_SpecMeasResBW} > 0$ Define $\text{SlotTimeInterval} = \text{TimeStep} * \text{int}((X/(\text{ACLR_SpecMeasResBW} * \text{TimeStep})) + 0.5)$ This means SlotTimeInterval is forced to a value that is an integer number of time step intervals. (Stop-Start) time is forced to be an integer number (M) of the SlotTimeInterval M has a minimum value of 1 Video averaging occurs over all SlotTimeIntervals The resolution bandwidth achieved is $\text{ResBW} = X / \text{SlotTimeInterval}$, which is very close to</p>

	<p>ACLR_SpecMeasResBW but may not be exactly the same if $X/(\text{ACLR_SpecMeasResBW} * \text{TimeStep})$ is not an exact integer.</p> <p>Resultant resolution BW = ResBW</p> <p>Resultant spectrum frequency step = ResBW</p> <p>Video averaging status = Yes, when $M > 1$</p>
--	---

7. ACLR_SpecMeasWindow specifies the window that will be applied to each slot before its spectrum is calculated. Different windows have different properties, affect the resolution bandwidth achieved, and affect spectral shape. Windowing is often necessary in transform-based (chirp-Z, FFT) spectrum estimation in order to reduce spectral distortion due to discontinuous or non-harmonic signal over the measurement time interval. Without windowing, the estimated spectrum may suffer from spectral leakage that can cause misleading measurements or masking of weak signal spectral detail by spurious artifacts.
- The windowing of a signal in time has the effect of changing its power. The spectrum measurement compensates for this and the spectrum is normalized so that the power contained in it is the same as the power of the input signal.

Window Type Definitions:

- none

$$w(kT_s) = \begin{cases} 1.0 & 0 \leq k \leq N \\ 0.0 & \textit{otherwise} \end{cases}$$

where N is the window size

- Hamming 0.54

$$w(kT_s) = \begin{cases} 0.54 - 0.46 \cos\left(\frac{2\pi k}{N}\right) & 0 \leq k \leq N \\ 0.0 & \textit{otherwise} \end{cases}$$

where N is the window size

- Hanning 0.50

$$w(kT_s) = \begin{cases} 0.5 - 0.5 \cos\left(\frac{2\pi k}{N}\right) & 0 \leq k \leq N \\ 0.0 & \textit{otherwise} \end{cases}$$

where N is the window size

- Gaussian 0.75

$$w(kT_s) = \begin{cases} \exp\left(-\frac{1}{2} \left(0.75 \frac{(2k - N)}{N}\right)^2\right) & 0 \leq \left|k - \frac{N}{2}\right| \leq \frac{N}{2} \\ 0.0 & \textit{otherwise} \end{cases}$$

where N is the window size

- Kaiser 7.865

$$w(kT_s) = \begin{cases} \frac{I_0\left(7.865\left[1 - \left(\frac{k-\alpha}{\alpha}\right)^2\right]^{1/2}\right)}{I_0(7.865)} & 0 \leq k \leq N \\ 0.0 & \textit{otherwise} \end{cases}$$

where N is the window size, $\alpha = N / 2$, and $I_0(\cdot)$ is the 0th order modified Bessel function of the first kind

- 8510 6.0 (Kaiser 6.0)

$$w(kT_s) = \begin{cases} \frac{I_0\left(6.0\left[1 - \left(\frac{k-\alpha}{\alpha}\right)^2\right]^{1/2}\right)}{I_0(6.0)} & 0 \leq k \leq N \\ 0.0 & \textit{otherwise} \end{cases}$$

where N is the window size, $\alpha = N / 2$, and $I_0(\cdot)$ is the 0th order modified Bessel function of the first kind

- Blackman

$$w(kT_s) = \begin{cases} 0.42 - 0.5 \cos\left(\frac{2\pi k}{N}\right) + 0.08 \cos\left(\frac{4\pi k}{N}\right) & 0 \leq k \leq N \\ 0.0 & \textit{otherwise} \end{cases}$$

where N is the window size

- Blackman-Harris

$$w(kT_s) = \begin{cases} 0.35875 - 0.48829 \cos\left(\frac{2\pi k}{N}\right) + 0.14128 \cos\left(\frac{4\pi k}{N}\right) - 0.01168 \cos\left(\frac{6\pi k}{N}\right) & 0 \leq k \leq N \\ 0.0 & \textit{otherwise} \end{cases}$$

where N is the window size.

Window Options and Normalized Equivalent Noise Bandwidth

Window and Default Constant	NENBW
none	1
Hamming 0.54	1.363
Hanning 0.50	1.5
Gaussian 0.75	1.883
Kaiser 7.865	1.653
8510 6.0	1.467
Blackman	1.727
Blackman-Harris	2.021

OBW Measurement Parameters

The occupied bandwidth measurement is implemented by the spectrum measurement which measures the spectrum of the input signal. The occupied bandwidth is calculated by analyzing the spectrum measured in data display files.

In the following notes, TimeStep denotes the simulation time step, and FMeasurement denotes the measured RF signal characterization frequency.

1. OBW_DisplayPages provides Data Display page information for this measurement. It cannot be changed by the user.
2. The measurement outputs the complex amplitude voltage values at spectral tone frequencies. Spectral tone frequency power is not output; however, power, magnitude, and phase spectrums can be calculated and displayed by using the dBm, mag, and phase functions of the data display window. Note that the dBm function assumes a 50-ohm measurement reference resistance; if a different measurement is used in the test bench, its value can be specified as a second argument to the dBm function; for example, dBm(SpecMeas, Meas_RefR), where SpecMeas is the instance name of the spectrum measurement and Meas_RefR is the resistive load.
By default, the displayed spectrum extends from FMeasurement - 1/(2TimeStep) Hz to FMeasurement + 1/(2TimeStep) Hz. When FMeasurement < 1/(2TimeStep), the default spectrum extends to negative frequencies. The spectral content at these negative frequencies is conjugated, mirrored, and added to the spectral content of the closest positive frequency. This way, the negative frequency tones are displayed on the positive frequency axis as would happen in an RF spectrum analyzer measurement instrument. This process may introduce an error in the displayed frequency for the mirrored tones. The absolute error introduced is less than (spectrum frequency step) / 2 (see the following table for the definition of spectrum frequency step).
The basis of the algorithm used by the spectrum measurement is the chirp-Z transform. The algorithm can use multiple slots and average the results to achieve video averaging (see [note 6](#)).
3. OBW_Start sets the start time for collecting input data.
4. OBW_Stop sets the stop time for collecting input data when OBW_Slots = 0 and OBW_SpecMeasResBW = 0.
5. OBW_Slots (when > 0) sets the number of slots over which data will be collected.
6. OBW_SpecMeasResBW (when > 0) sets the resolution bandwidth of the spectrum measurement.
Depending on the values of OBW_Stop, OBW_Slots, and OBW_SpecMeasResBW, the stop time may be adjusted and/or spectrum video averaging may occur. The different cases are explained in the following table.
Let:

$$\text{Start} = \text{TimeStep} \times \text{int}((\text{OBW_Start}/\text{TimeStep}) + 0.5)$$

$$\text{Stop} = \text{TimeStep} \times \text{int}((\text{OBW_Stop}/\text{TimeStep}) + 0.5)$$

(This means Start and Stop are forced to be an integer number of time step intervals.)

X be the Normalized Equivalent Noise BW of the window used

Equivalent noise bandwidth (ENBW) compares the window to an ideal, rectangular filter. It is the equivalent width of a rectangular filter that passes the same amount of white noise as the window. The normalized ENBW is the ENBW multiplied by the time duration of the signal being windowed. See [Window Options and Normalized Equivalent Noise Bandwidth](#) for the normalized ENBW for the different window options.

The Start and Stop times are used for both the RF_out and Meas_in signal spectrum analyses. The Meas_in signal is delayed in time from the RF_out signal by the value of the RF DUT time delay. Thus for RF DUT time delay > 0, the RF_out and Meas_in signal are inherently different and some spectrum display difference in the

Advanced Design System 2008

two is expected.

TimeStep and SlotTime are defined in [Test Bench Variables for Data Displays](#).

Effect of Different Values for OBW_Stop, OBW_Slots, and OBW_SpecMeasResBW

Case 1	<p>OBW_Slots = 0 OBW_SpecMeasResBW = 0 Resultant stop time = Stop Resultant resolution BW = $X / (\text{Stop} - \text{Start})$ Resultant spectrum frequency step = $1 / (\text{Stop} - \text{Start})$ Video averaging status = None</p>
Case 2	<p>OBW_Slots > 0 OBW_SpecMeasResBW = 0 Resultant stop time = Start + OBW_Slots x SlotTime For OBW_Slots > 0 and OBW_SpecMeasResBW = 0 Video averaging occurs over all slot time intervals Resultant resolution BW = $X / \text{SlotTime}$ Resultant spectrum frequency step = $1 / \text{SlotTime}$ Video averaging status = Yes, when OBW_Slots > 1</p>
Case 3	<p>OBW_Slots = 0 OBW_SpecMeasResBW > 0 Resultant stop time = Start + N*SlotTimeInterval where $N = \text{int}((\text{Stop} - \text{Start}) / \text{SlotTimeInterval}) + 1$ For OBW_Slots = 0 and OBW_SpecMeasResBW > 0 Define SlotTimeInterval = TimeStep * $\text{int}(X / (\text{OBW_SpecMeasResBW} * \text{TimeStep})) + 0.5)$ This means SlotTimeInterval is forced to a value that is an integer number of time step intervals. (Stop-Start) time is forced to be an integer number (N) of SlotTimeInterval N has a minimum value of 1 Video averaging occurs over all SlotTimeInterval The resolution bandwidth achieved is $\text{ResBW} = X / \text{SlotTimeInterval}$, which is very close to OBW_SpecMeasResBW but may not be exactly the same if $X / (\text{OBW_SpecMeasResBW} * \text{TimeStep})$ is not an exact integer. Resultant resolution BW = ResBW Resultant spectrum frequency step = ResBW Video averaging status = Yes when N > 1</p>
Case 4	<p>OBW_Slots > 0 OBW_SpecMeasResBW > 0 Resultant stop time = Start + M*SlotTimeInterval where $M = \text{int}((\text{OBW_Slots} * \text{SlotTime}) / \text{SlotTimeInterval}) + 1$ For OBW_Slots > 0 and OBW_SpecMeasResBW > 0</p>

Define SlotTimeInterval = TimeStep *
 $\text{int}((X/(\text{OBW_SpecMeasResBW}*\text{TimeStep})) + 0.5)$
 This means SlotTimeInterval is forced to a value that is an integer number of time step intervals.
 (Stop-Start) time is forced to be an integer number (M) of the SlotTimeInterval
 M has a minimum value of 1
 Video averaging occurs over all SlotTimeInterval
 The resolution bandwidth achieved is $\text{ResBW} = X / \text{SlotTimeInterval}$, which is very close to OBW_SpecMeasResBW but may not be exactly the same if $X/(\text{OBW_SpecMeasResBW}*\text{TimeStep})$ is not an exact integer.
 Resultant resolution BW = ResBW
 Resultant spectrum frequency step = ResBW
 Video averaging status = Yes, when $M > 1$

7. OBW_SpecMeasWindow sets the window that can be used. Different windows have different properties, affect the resolution bandwidth achieved, and affect spectral shape. The OBW_SpecMeasWindow is used to define the window that will be applied to each slot before its spectrum is calculated. Windowing is often necessary in transform-based (chirp-Z, FFT) spectrum estimation in order to reduce spectral distortion due to discontinuous or non-harmonic signal over the measurement time interval. Without windowing, the estimated spectrum may suffer from spectral leakage that can cause misleading measurements or masking of weak signal spectral detail by spurious artifacts.

The windowing of a signal in time has the effect of changing its power. The spectrum measurement compensates for this and the spectrum is normalized so that the power contained in it is the same as the power of the input signal.

Window Type Definitions:

- none

$$w(kT_s) = \begin{cases} 1.0 & 0 \leq k \leq N \\ 0.0 & \textit{otherwise} \end{cases}$$

where N is the window size

- Hamming 0.54

$$w(kT_s) = \begin{cases} 0.54 - 0.46 \cos\left(\frac{2\pi k}{N}\right) & 0 \leq k \leq N \\ 0.0 & \textit{otherwise} \end{cases}$$

where N is the window size

- Hanning 0.50

$$w(kT_s) = \begin{cases} 0.5 - 0.5 \cos\left(\frac{2\pi k}{N}\right) & 0 \leq k \leq N \\ 0.0 & \textit{otherwise} \end{cases}$$

where N is the window size

- Gaussian 0.75

$$w(kT_s) = \begin{cases} \exp\left(-\frac{1}{2}\left(0.75\frac{(2k-N)^2}{N}\right)\right) & 0 \leq \left|k - \frac{N}{2}\right| \leq \frac{N}{2} \\ 0.0 & \textit{otherwise} \end{cases}$$

where N is the window size

- Kaiser 7.865

$$w(kT_s) = \begin{cases} \frac{I_0\left(7.865\left[1 - \left(\frac{k-\alpha}{\alpha}\right)^2\right]^{1/2}\right)}{I_0(7.865)} & 0 \leq k \leq N \\ 0.0 & \textit{otherwise} \end{cases}$$

where N is the window size, $\alpha = N / 2$, and $I_0(\cdot)$ is the 0th order modified Bessel function of the first kind

- 8510 6.0 (Kaiser 6.0)

$$w(kT_s) = \begin{cases} \frac{I_0\left(6.0\left[1 - \left(\frac{k-\alpha}{\alpha}\right)^2\right]^{1/2}\right)}{I_0(6.0)} & 0 \leq k \leq N \\ 0.0 & \textit{otherwise} \end{cases}$$

where N is the window size, $\alpha = N / 2$, and $I_0(\cdot)$ is the 0th order modified Bessel function of the first kind

- Blackman

$$w(kT_s) = \begin{cases} 0.42 - 0.5 \cos\left(\frac{2\pi k}{N}\right) + 0.08 \cos\left(\frac{4\pi k}{N}\right) & 0 \leq k \leq N \\ 0.0 & \textit{otherwise} \end{cases}$$

where N is the window size

- Blackman-Harris

$$w(kT_s) = \begin{cases} 0.35875 - 0.48829 \cos\left(\frac{2\pi k}{N}\right) + 0.14128 \cos\left(\frac{4\pi k}{N}\right) - 0.01168 \cos\left(\frac{6\pi k}{N}\right) & 0 \leq k \leq N \\ 0.0 & \textit{otherwise} \end{cases}$$

where N is the window size.

Window Options and Normalized Equivalent Noise Bandwidth

Window and Default Constant	NENBW
none	1
Hamming 0.54	1.363
Hanning 0.50	1.5
Gaussian 0.75	1.883
Kaiser 7.865	1.653

8510 6.0	1.467
Blackman	1.727
Blackman-Harris	2.021

CDP Measurement Parameters

1. CDP_DisplayPages provides Data Display page information for this measurement. It cannot be changed by the user.
2. CDP_StartSlot sets starting slot from which data will be collected. CDP_StartSlot is used for RF_out and Meas_in CDP analyses.

The measurement interval is one timeslot. The length of time that data will be collected is SlotTime ([Test Bench Equations Derived from Test Bench Parameters and Exported to Data Display](#) describes SlotTime).

PCDE Measurement Parameters

1. PCDE_DisplayPages provides Data Display page information for this measurement. It cannot be changed by the user.
2. PCDE_StartSlot sets the starting slot from which data will be collected. PCDE_StartSlot is used for RF_out and Meas_in PCDE analyses.

The measurement interval is one timeslot. The length of time that data will be collected is SlotTime ([Test Bench Equations Derived from Test Bench Parameters and Exported to Data Display](#) describes SlotTime).

EVM Measurement Parameters

1. EVM_DisplayPages provides Data Display page information for this measurement. It cannot be changed by the user.
2. EVM_Start specifies starting time instant for the measurement. EVM_Start time is used for RF_out and Meas_in EVM analyses. The Meas_in signal is delayed in time from the RF_out signal by the RF DUT time delay value. Thus for RF DUT time delay >0, RF_out and Meas_in signals are inherently different and some EVM difference in the two is expected even if the RF DUT does not introduce any distortion other than time delay.
3. EVM_SlotsMeasured specifies the measurement interval. The time length of data to be collected is $EVM_SlotMeasured \times SlotTime$ ([Test Bench Equations Derived from Test Bench Parameters and Exported to Data Display](#) describes SlotTime).

Signal to ESG Parameters

The EVM measurement collects data from the Meas_in signal and downloads it to an Agilent E4438C Vector Signal Generator. This measurement uses Connection Manager architecture to communicate with the instrument; parameters specify how data is interpreted.

Prerequisites for using the Signal to ESG option are:

- ESG Vector Signal Generator E4438C; for information, visit the web site [<http://www.agilent.com/find/esg>].
- PC workstation running an instance of the connection manager server.
- Supported method of connecting the instrument to your computer through the Connection Manager architecture; for information, see Connection Manager.

Parameter Information

1. EnableESG specifies if the signal is downloaded to the ESG instrument. If set to NO, no attempt will be made to communicate with the instrument.
2. ESG_Instrument specifies a triplet that identifies the VSA resource of the instrument to be used in the simulation, the connection manager server hostname (defaults to localhost), and the port at which the connection manager server listens for incoming requests (defaults to 4790). To ensure that this field is populated correctly, click Select Instrument, enter the server hostname and port, click OK to see the Remote Instrument Explorer dialog, select a VSA resource identifier, and click OK. For details about selecting instruments, see Instrument Discovery in the Wireless Test Bench Simulation documentation.
3. ESG_Start and ESG_Stop (when ESG_Slots=0) specify when to start and stop data collection. The number of samples collected, $ESG_Stop - ESG_Start + 1$, must be in the range 60 samples to 64 Msamples, where 1 Msample = 1,048,576 samples. The ESG requires an even number of samples; the last sample will be discarded if $ESG_Stop - ESG_Start + 1$ is odd.
4. ESG_Slots sets the number of slots over which data will be collected. When $ESG_Slots > 0$, ESG_Stop is forced to $ESG_Start + ESG_Slots \times SlotTime$ (where SlotTime is 5 msec).
5. ESG_ClkRef specifies an internal or external reference for the ESG clock generator. If set to External, the ESG_ExtClkRefFreq parameter sets the frequency of this clock.
6. ESG_IQFilter specifies the cutoff frequency for the reconstruction filter that lies between the DAC output and the Dual Arbitrary Waveform Generator output inside the ESG.
7. ESG_SampleClkRate sets the sample clock rate for the DAC output.
8. ESG_FileName sets the name of the waveform inside the ESG that will hold the downloaded data.
9. The ESG driver expects data in the range $\{-1, 1\}$. ESG_AutoScaling specifies whether to scale inputs to fit this range. If set to YES, inputs are scaled to the range $\{-1, 1\}$; if set to NO, raw simulation data is downloaded to the ESG without any scaling, but data outside the range $\{-1, 1\}$ is clipped to -1 or 1. If set to YES, scaling is also applied to data written to the local file (ESG_FileName setting).
10. If ESG_ArbOn is set to YES, the ESG will start generating the signal immediately after simulation data is downloaded; if set to NO, waveform generation must be turned on at the ESG front panel.
11. If ESG_RFPowOn is set to YES, the ESG will turn RF power on immediately after simulation data is downloaded. If ESG_RFPowOn is set to NO (default), RF power must be turned on at the ESG front panel.
12. ESG_EventMarkerType specifies which ESG Event markers are enabled: Event1, Event2, Both, or Neither. Event

markers are used for synchronizing other instruments to the ESG. When one or both EventMarkers are enabled, Event1 and/or Event2 is set beginning from the first sample of the downloaded Arb waveform over the range of points specified by the ESG_MarkerLength parameter. This is equivalent to setting the corresponding event from the front panel of the ESG.

13. ESG_MarkerLength specifies the range of points over which the markers must be set starting from the first point of the waveform. Depending on the setting of ESG_EventMarkerType, the length of trigger Event1 or Event2 (or both) is set to a multiple of the pulsewidth that, in turn, is determined by the sample clock rate of the DAC output.

Simulation Measurement Displays

After running the simulation, results are displayed in the Data Display pages for each measurement activated.

 **Note**
Measurement results from a wireless test bench have associated names that can be used in Data Display Expressions. For more information, refer to [Measurement Results for Expressions for 3GPP FDD Wireless Test Benches](#).

RF Envelope Measurement

The RF Envelope measurement (not defined in 3GPP specifications) measures the RF signal at the input of the RF DUT, and the Meas signal at the output of the RF DUT. Test Model 4 is used. The following figure shows the results.

The DUT delay (also displayed) is calculated by comparing the markers on the waveforms of RF_out (before DUT) and Meas_in (after DUT).

...RF_F Source V(1 MHz)	real(RF_Power_dBm)	real(RF_R)	...easurement V(1 MHz)	real(Meas_RefR)
2140.000	43.000	50.000	2140.000	50.000
real(ChipRate V(1 MHz))	real(ChipsPerSlot)	real(SlotTime V(1 usec))	real(FrameTime V(1msec))	
3.840	2560.000	666.667	10.000	

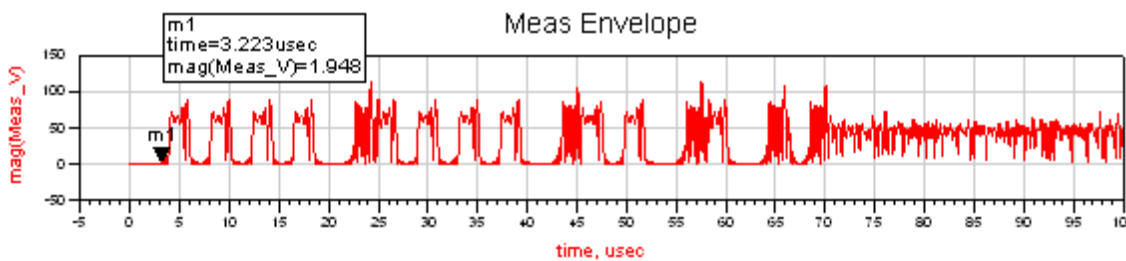
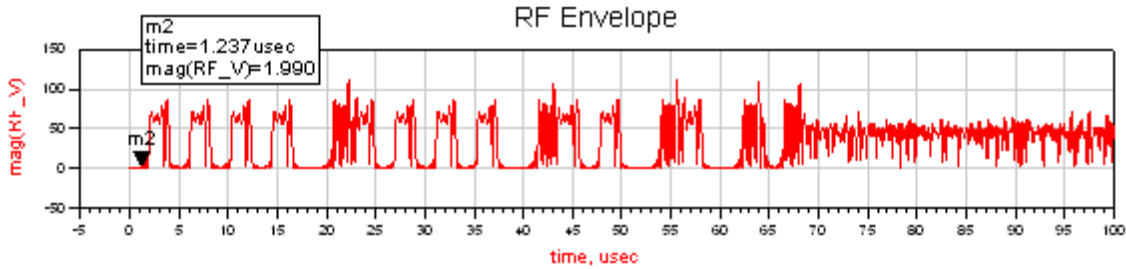

Eqn Delay=indep(m1)-indep(m2)

Delay(1usec)
1.986

RF Envelope Measurement Results

Power Measurement

The power measurement (not defined in 3GPP specifications) shows transmitter CCDF curves. The CCDF and peak-to-average ratio of RF_out signal before the DUT and the Meas_in signal after the DUT are measured.

Test Model 1 is used. The following figure shows the mean power, peak power and peak-to-mean ratio of the signals.

Advanced Design System 2008

...RF_FSource)(1 MHz)	real(RF_Power_dBm)	real(RF_R)	...easurement)(1 MHz)	real(Meas_RefR)
2140.000	43.000	50.000	2140.000	50.000

Not defined in 3GPP FDD Specification

Meas Power

Meas_MeanPower_dBm	Meas_PeakPower_dBm	Meas_Peak_to_Mean_Ratio_dB
43.095	51.780	8.685

RF Power

RF_MeanPower_dBm	RF_PeakPower_dBm	RF_Peak_to_Mean_Ratio_dB
43.147	51.730	8.583

Signal Ratios

The following figure shows the CCDF curves.

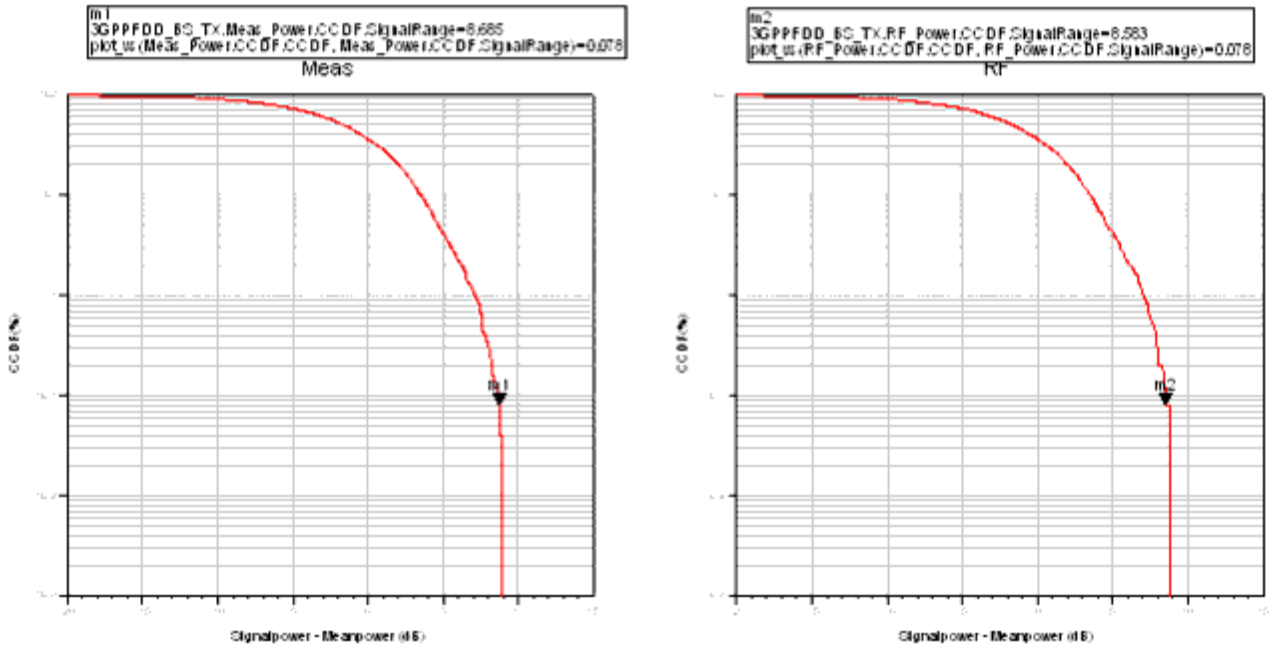

CCDF Curves

ACLR Measurement

The adjacent channel leakage power ratio (ACLR) measurement is defined in 3GPP TS 25.104, section 6.6.2.2. Test Model 1 is used.

Advanced Design System 2008

ACLR is the ratio of the transmitted power to the power measured in an adjacent channel. Both the transmitted and the adjacent channel power are measured through a matched filter (root raised cosine and roll-off 0.22) with a noise power bandwidth equal to the chip rate. The ACLR of the RF_out signal before the DUT and Meas_in signal after the DUT are measured.

The ACLR must be higher than the value specified in the following table.

Base Station ACLR

Base Station Adjacent Channel Offset †	ACLR Limit
5 MHz	45 dB
10 MHz	50 dB
† Offset below the first or above the last carrier frequency used.	

The following figure shows the power of adjacent channels and the ACLR. Test results and requirements are also shown.

Advanced Design System 2008

...F_Source)(1 MHz)	real(RF_Power_dBm)	real(RF_R)	...easurement)(1 MHz)	real(Meas_ReR)
2140.000	43.000	50.000	2140.000	50.000

RF Main, Upper, and Lower Channel Powers (dBm)

RF_Main_Ch_Pwr	RF_U10_Ch_Pwr	RF_U5_Ch_Pwr	RF_L5_Ch_Pwr	RF_L10_Ch_Pwr
42.736634	-21.742129	-12.178076	-12.159219	-21.627330

ACLR (dB)

RF_ACLR_U10	RF_ACLR_U5	RF_ACLR_L5	RF_ACLR_L10
64.478764	54.914711	54.895854	64.363965

Meas Main, Upper, and Lower Channel Powers (dBm)

Meas_Main_Ch_Pwr	Meas_U10_Ch_Pwr	Meas_U5_Ch_Pwr	Meas_L5_Ch_Pwr	Meas_L10_Ch_Pwr
42.688118	-26.589068	-12.936630	-12.928227	-26.447242

ACLR (dB)

Meas_ACLR_U10	Meas_ACLR_U5	Meas_ACLR_L5	Meas_ACLR_L10
69.277186	55.824748	55.818345	69.136360

3GPP Specification TS 25.104 V4.4.0 section 6.6

Specification requirements

+5 MHz or -5 MHz	45 dB
+10 MHz or -10 MHz	50 dB

If the adjacent channel power is greater than -50dBm then the ACLR shall be higher than the above value .

Test Results

Passed

ACLR Measurement Results

The following figure shows the spectrums of the main and the adjacent channels.

real(RF_Source)(1 MHz)	real(RF_Power_dBm)	real(RF_P)	..._in_Measurement)(1 MHz)	real(Meas_RefP)
2140.000	+3.000	50.000	2140.000	50.000

RF ACLR

Meas ACLR

Main Channel Spectrum

Main Channel Spectrum

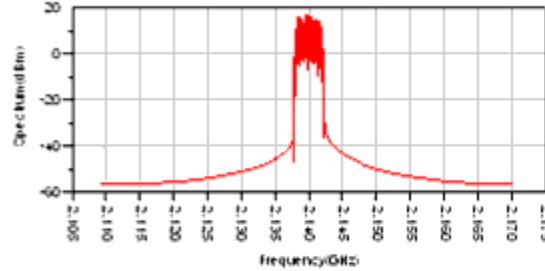
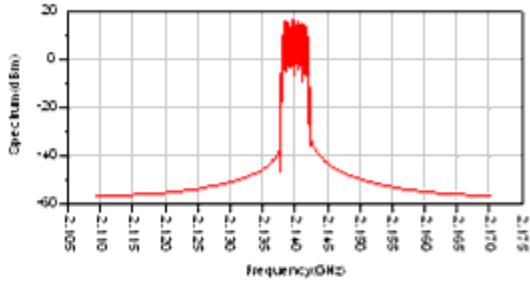

Spectrum of 10MHz and 5 MHz Higher than Main Channel

Spectrum of 10MHz and 5 MHz Higher than Main Channel

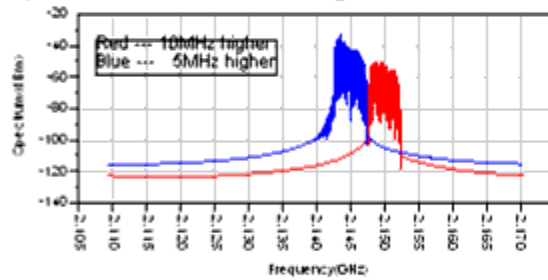
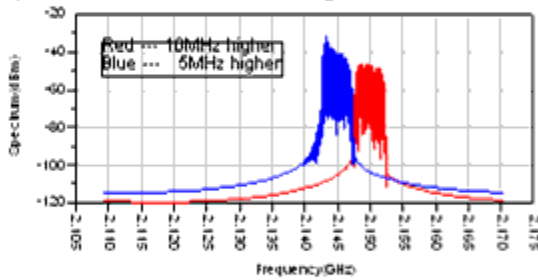

Spectrum of 10MHz and 5 MHz Lower than Main Channel

Spectrum of 10MHz and 5 MHz Lower than Main Channel

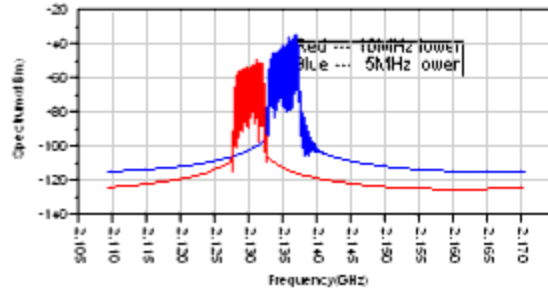
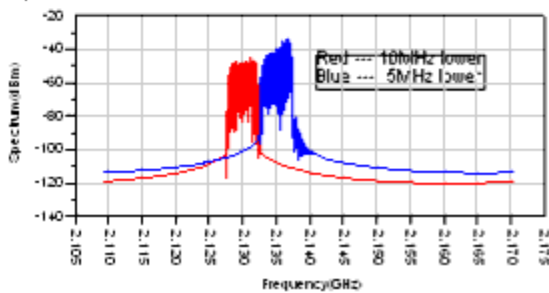

ACLR Spectrums

Occupied Bandwidth Measurement

The occupied bandwidth (OBW) measurement is defined in 3GPP TS 25.104, section 6.6.1. OBW is a measure of the bandwidth containing 99% of the total integrated power for transmitted spectrum and is centered on the assigned channel frequency. The occupied channel bandwidth must be less than 5 MHz based on a chip rate of 3.84 Mcps.

The OBW of RF_out signal before the DUT and the Meas_in signal after the DUT is measured. Test Model 1 is used. The following figure shows the signal spectrums. The markers are moved so that the higher and lower percentages of the spectrum add up to 1% of the total power.

...ource)/(1 MHz)	..._Power_dBm)	real(RF_R)	...ement)/(1 MHz)	real(Meas_RefR)
2140.000	43.000	50.000	2140.000	50.000

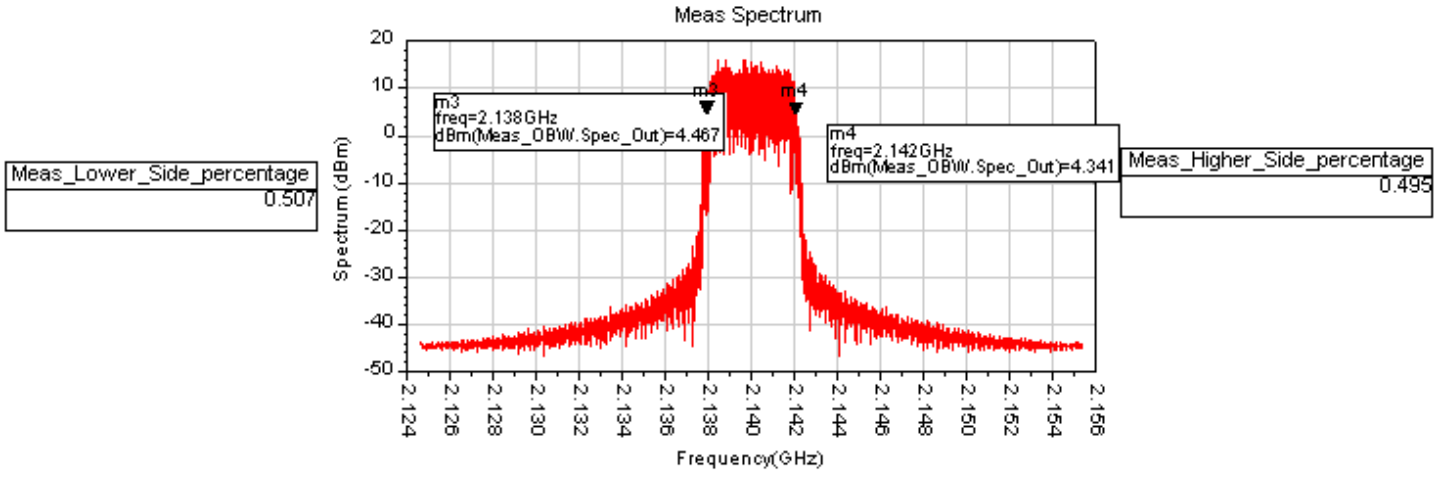
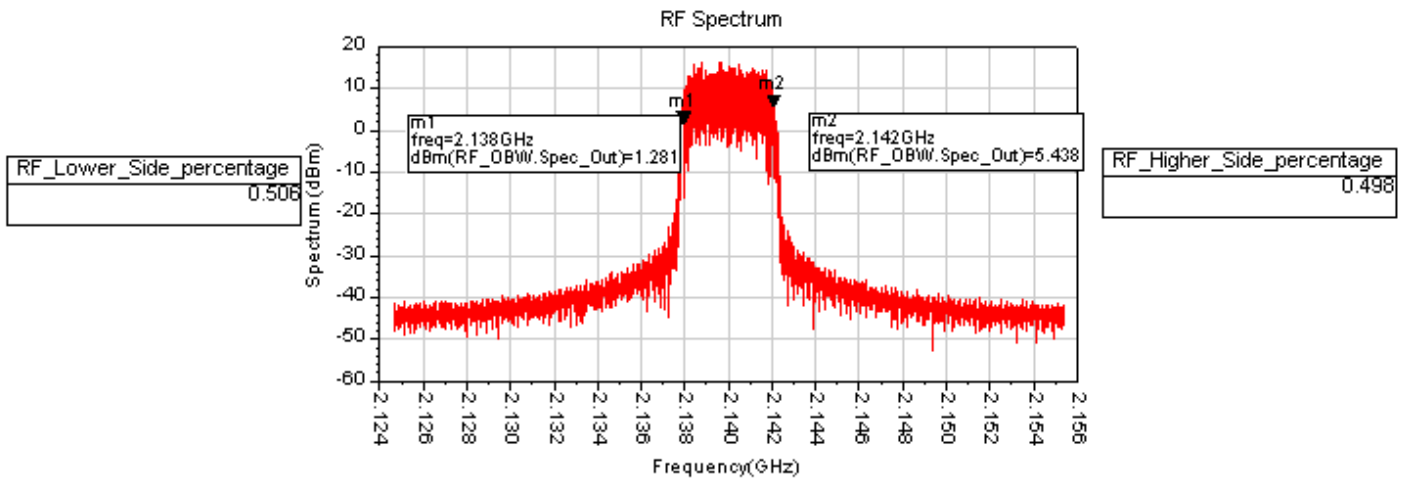

Move markers with up/down arrow keys until the Lower Side and Higher Side power ratio equals to 0.5%. The Occupied_BW will then display the resulting bandwidth containing 99% of the transmitted power.

Occupied Bandwidth Signal Spectrums

The following figure shows the resolution bandwidth and the occupied bandwidth of the signals.

Advanced Design System 2008

...(RF_F Source)(1 MHz)	real(RF_Power_dBm)	real(RF_R)	...Measurement)(1 MHz)	real(Meas_RefR)
2140.000	43.000	50.000	2140.000	50.000

RF OccupiedBW

RF_Occupied_BandWidth_MHz	Resolution_BandWidth_KHz
4.160	1.500

Meas Power

RF_Lower_Side_percentage	RF_Higher_Side_percentage	RF_Total_Power_WWatt
0.506	0.498	20.029

Meas OccupiedBW

Meas_Occupied_BandWidth_MHz	Resolution_BandWidth_KHz
4.154	1.500

Meas Power

Meas_Lower_Side_percentage	Meas_Higher_Side_percentage	Meas_Total_Power_WWatt
0.507	0.495	19.776

3GPP Specification TS 25.104 V4.4.0 section 6.6.1

Specification requirements

The occupied channel bandwidth shall be less than 5MHz base on a chip rate of 3.84 Mcps.
(Section 6.6.1 of TS 25.104 v4.4.0)

Test results

Passed

Occupied Bandwidth Measurement Results

CDP Measurement

The code domain power (CDP) measurement (not defined in 3GPP specifications) is a measure of power distribution on code domain. CDP is calculated by projecting the power onto the code domain at a specified spread factor (256). The CDP for every code in the domain is defined as the ratio of the mean power of the projection onto that code, to the mean power of the composite reference waveform. The measurement interval is one timeslot. Test Model 3 is used.

The following figure shows the CDP before and after the DUT.

real(RF_FSource)/(1 MHz)	real(RF_Power_dBm)	real(RF_R)	...FMeasurement)/(1 MHz)	real(Meas_RefR)
2140.000	43.000	50.000	2140.000	50.000

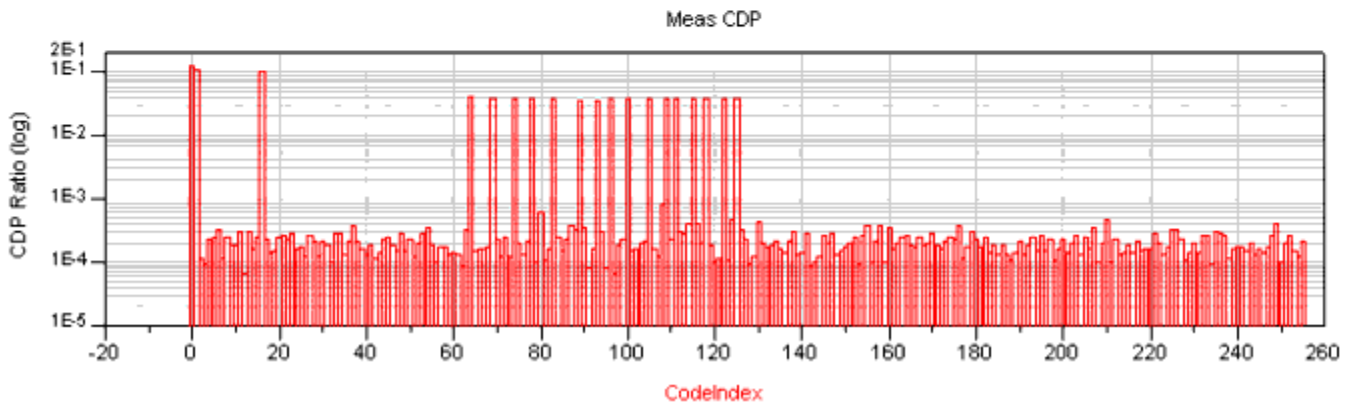
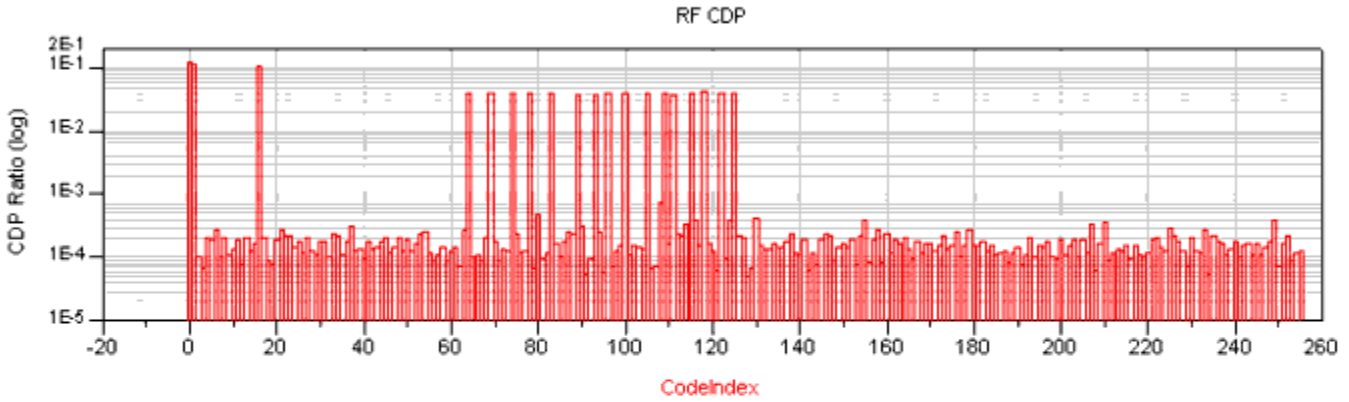

CDP Measurement Results

PCDE Measurement

This peak code domain error (PCDE) measurement is defined in 3GPP TS 25.104, section 6.8.3. PCDE is calculated by projecting the power of the error vector onto the code domain at a specified spread factor. The code domain error for every code in the domain is defined as the ratio of the mean power of the projection onto that code, to the mean power of the composite reference waveform. This ratio is expressed in dB. The PCDE is defined as the maximum value for the code domain error for all codes. The measurement interval is one timeslot. At a spreading factor of 256, the PCDE must not exceed -33dB.

Test Model 3 is used. The following figure shows the PCDE figures before and after the DUT. Markers mark the peak

error and the codes.

real(RF_FSource)/(1 MHz)	real(RF_Power_dBm)	real(RF_R)	...Meas_FMeasTime/(1 MHz)	real(Meas_PeR)
2140.000	43.000	50.000	2140.000	50.000

m1
 3GPPFDD_BS_TX.Meas_PCDE.CodeDomainErr.CDE_CodeIndex<=0.000
 plot_vs(RF_CDE, Meas_PCDE.CodeDomainErr.CDE_CodeIndex)=-274.395

RF Code Domain Error

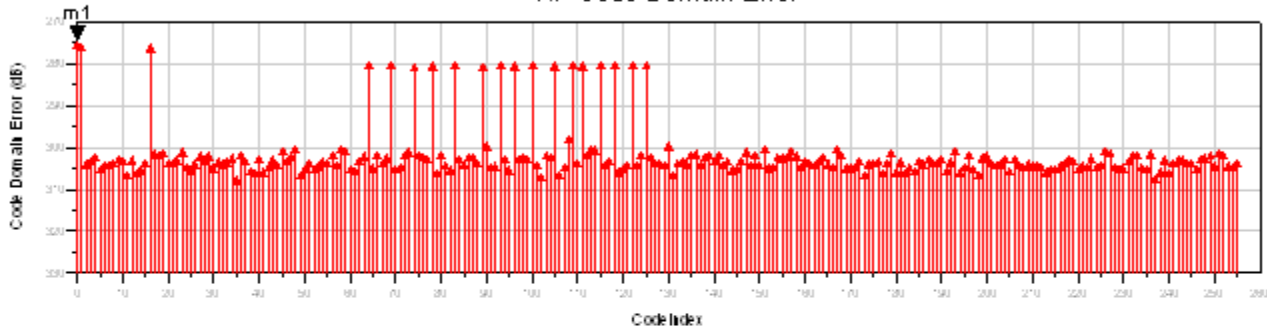

m2
 3GPPFDD_BS_TX.Meas_PCDE.CodeDomainErr.CDE_CodeIndex<=72.000
 plot_vs(Meas_CDE, Meas_PCDE.CodeDomainErr.CDE_CodeIndex)=-61.117

Meas Code Domain Error

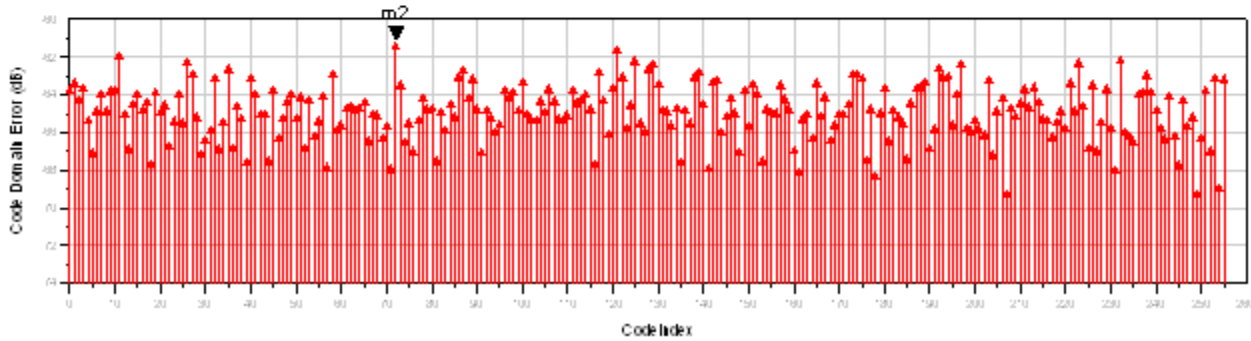

PCDE Waveforms

The following figure shows the PCDE table. The result is also displayed according to the specification.

Advanced Design System 2008

...(RF_FSource)(1 MHz)	real(RF_Power_dBm)	real(RF_R)	...easurement)(1 MHz)	real(Meas_RefR)
2140.000	43.000	50.000	2140.000	50.000

RF Peak Code Domain Error (dB)

RF_PCDE_dB
-274.395

Meas Peak Code Domain Error (dB)

Meas_PCDE_dB
-61.117

Specification requirements

The peak code domain error shall not exceed -33 dB

Test results

Passed

PCDE Measurement Results

EVM Measurement

This error vector magnitude (EVM) measurement is defined in 3GPP TS 25.104, section 6.8.2. EVM is a measure of the difference between the theoretical waveform and a modified version of the measured waveform. This difference is called the error vector. The measured waveform is modified by first passing it through a matched root raised-cosine filter with a bandwidth of 3.84MHz and 0.22 roll-off. The waveform is then further modified by selecting the frequency, absolute phase, absolute amplitude, and chip clock timing so as to minimize the error vector. The EVM result is defined as the root of the mean error vector power to the mean reference signal power expressed as a percent. The EVM cannot exceed 17.5%.

Test Model 4 is used for this measurement.

The following figure shows the results of the EVM before and after the DUT.

Advanced Design System 2008

...(RF_FSource)(1 MHz)	real(RF_Power_dBm)	real(RF_R)	...easurement)(1 MHz)	real(Meas_RefR)
2140.000	43.000	50.000	2140.000	50.000

Meas EVM(%)

	0.049684
	0.049295

RF EVM(%)

	2.691825E-13
	3.630164E-13

3GPP Specification TS 25.104 V4.4.0 section 6.8.2

Specification requirements

The modulation accuracy EVM shall not exceed 17.5% for the parameters specified in Table 6.15 of TS 25.104 V4.4.0 section 6.8.2

Test results

Passed
Passed

EVM Measurement Results

Test Bench Variables for Data Displays

Reference variables used to set up this test bench are listed in the following tables.

Test Bench Constants for Base Station Signal Setup

Constant	Value
SamplesPerChip	8
ChipRate	3.84 MHz
ChipsPerSlot	2560
SlotsPerFrame	15

SourceType Determines Type of Source

SourceType	Type of Source
TestMode1_16DPCHs	Test Model 1 with 16 DPCHs (Test Model 1 Active Channels)
TestMode1_32DPCHs	Test Model 1 with 32 DPCHs (Test Model 1 Active Channels)

Advanced Design System 2008

TestMode1_64DPCHs	Test Model 1 with 64 DPCHs (Test Model 1 Active Channels)
TestMode2	Test Model 2 (Test Model 2 Active Channels)
TestMode3_16DPCHs	Test Model 3 with 16 DPCHs (Test Model 3 Active Channels)
TestMode3_32DPCHs	Test Model 2 with 16 DPCHs (Test Model 3 Active Channels)
TestMode4	Test Model 4 (Test Model 4 Active Channels)

Test Bench Equations Derived from Test Bench Parameters and Exported to Data Display

Data Display Parameter	Equation with Test Bench Parameters
RF_FSource	FSource
RF_Power_dBm	$10 * \log_{10}(\text{SourcePower}) + 30$
RF_R	SourceR
TimeStep	$1 / (\text{ChipRate} * \text{SamplesPerChip})$ This is the test bench simulation time step
SlotTime	$\text{ChipsPerSlot} * \text{SamplesPerChip} * \text{TimeStep}$ This is the time duration of each slot
FrameTime	$\text{SlotTime} * \text{SlotsPerFrame}$
Meas_FMeasurement	FMeasurement
Meas_R	MeasR

Baseline Performance

- Test Computer Configuration
 - Pentium IV 2.4 GHz, 512 MB RAM, Red Hat Linux 7.3
- Conditions
 - Measurements made with default test bench settings.
 - RF DUT is an RF system behavior component.
 - The number of time points in one slot can be calculated by SamplesPerChip times ChipsPerSlot.
 ChipRate = 3.84 MHz
 SamplesPerChip = 8
 ChipsPerSlot = 2560
 - Resultant $\text{WTB_TimeStep} = 32.6 \text{ nsec}$; $\text{SlotTime} = 666.7 \mu$ time points per slot = 20480
- Simulation times and memory requirements.

Measurement	Slots Measured	Simulation Time (sec)	ADS Processes (MB)
-------------	----------------	-----------------------	--------------------

Advanced Design System 2008

RF_Envelope	1	10.5	183
Power	1	5	179
ACLR	1	82	215
Occupied BW	1	11	186
CDP	1	206	179
PCDE	1	450	179
EVM	1	450	179

Expected ADS Performance

Expected ADS performance is the combined performance of the baseline test bench and the RF DUT Circuit Envelope simulation with the same signal and number of time points. For example, if the RF DUT performance with Circuit Envelope simulation alone takes 2 hours and consumes 200 MB of memory (excluding the memory consumed by the core ADS product), then add these numbers to the Baseline Performance numbers to determine the expected ADS performance. This is valid only if the full memory consumed is from RAM. If RAM is less, larger simulation times may result due to increased disk access time for swap memory usage.

References

1. 3GPP Technical Specification TS 25.211, "Physical channels and mapping of transport channels onto physical channels (FDD)" Release 1999.
http://www.3gpp.org/ftp/Specs/2002-03/R1999/25_series/25211-3a0.zip
2. 3GPP Technical Specification TS 25.212, "Multiplexing and Channel Coding (FDD)" Release 1999.
http://www.3gpp.org/ftp/Specs/2002-03/R1999/25_series/25212-390.zip
3. 3GPP Technical Specification TS 25.213, "Spreading and modulation (FDD)" Release 1999.
http://www.3gpp.org/ftp/Specs/2002-03/R1999/25_series/25213-370.zip
4. 3GPP Technical Specification TS 25.104, "UTRA (BS) FDD; Radio transmission and Reception" Release 1999.
http://www.3gpp.org/ftp/Specs/2002-03/R1999/25_series/25104-3a0.zip
5. 3GPP Technical Specification TS 25.141, "Base station conformance testing (FDD)" Release 1999.
http://www.3gpp.org/ftp/Specs/2002-03/R1999/25_series/25141-390.zip

Setting up a Wireless Test Bench Analysis in the Wireless Test Bench Simulation documentation explains how to use test bench windows and dialogs to perform analysis tasks.

Setting Circuit Envelope Analysis Parameters in the Wireless Test Bench Simulation documentation explains how to set up circuit envelope analysis parameters such as convergence criteria, solver selection, and initial guess.

Setting Automatic Behavioral Modeling Parameters in the Wireless Test Bench Simulation documentation to learn how

to improve simulation speed.

3GPP FDD User Equipment Transmitter Test

3GPPFDD_UE_TX is the test bench for 3GPP FDD user equipment transmitter testing. The test bench provides a way for users to connect to an RF circuit device under test and determine its performance by activating various test bench measurements. This test bench provides signal measurements for RF envelope, power (including CCDF), occupied bandwidth, adjacent channel leakage power ratio, adjacent channel leakage power ratio due to switching transients, code and peak code domain power, and EVM.

The signal and most of the measurements are designed according to the 3GPP Technical Specification TS 25.101 and TS 34.121. Versions supported are 2000-03, 2000-12, and 2002-03.

This 3GPP FDD signal model is compatible with Agilent E4438C ESG Vector Signal Generator, Option 400 (3GPP W-CDMA Firmware Option for the E4438C ESG Vector Signal Generator). Details regarding Agilent E4438C ESG are included at the website <http://www.agilent.com/find/esg>.

The DUT output signal can be sent to an Agilent ESG RF signal generator.

This test bench includes a DSP section, an RF modulator, RF output source resistance, RF DUT connection, RF receivers, and DSP measurement blocks, as illustrated in the following figure. The generated test signal is sent to the DUT.

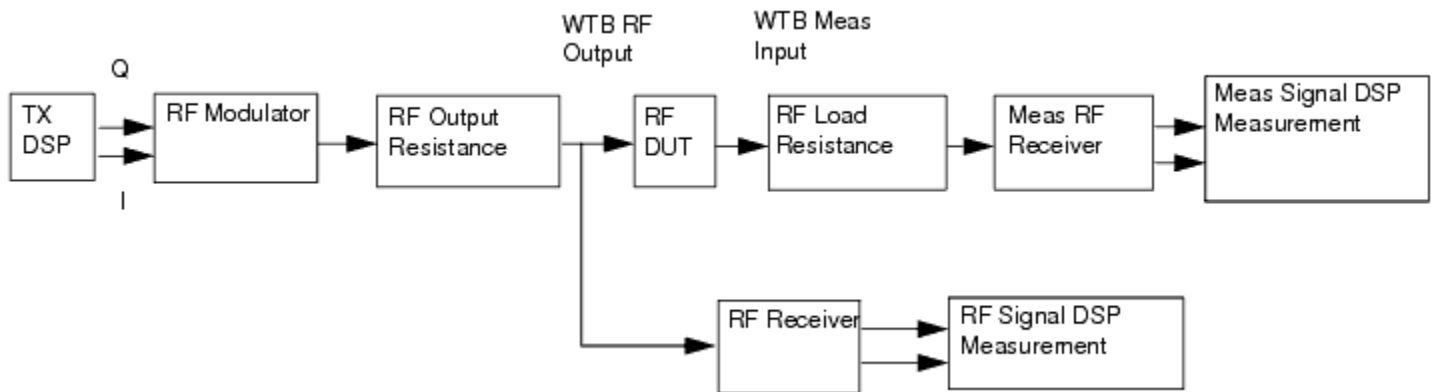

Transmitter Wireless Test Bench Block Diagram

In the 3GPP uplink signal frame structure, one frame has a duration of 10 msec and consists of 15 slots. Each slot corresponds to one power control period and contains 2560 chips.

There are two types of uplink dedicated physical channels - uplink dedicated physical data channel (uplink DPDCH) and uplink dedicated physical control channel (uplink DPCCH). These channels are I/Q code multiplexed within each radio frame.

Uplink DPDCH is used to carry the DCH transport channel. There may be zero, one, or several uplink DPDCHs on each radio link.

Uplink DPCCH is used to carry control information generated at Layer 1. Layer 1 control information consists of known pilot bits to support channel estimation for coherent detection, transmit power-control (TPC) commands, feedback information (FBI), and an optional transport-format combination indicator (TFCI). The TFCI informs the receiver about the instantaneous transport format combination of the transport channels mapped to the simultaneously transmitted uplink DPDCH radio frame. There is only one uplink DPCCH on each radio link.

The frame structure of the uplink dedicated physical channels is illustrated in the following figure. The following 4 tables provide more information about each field.

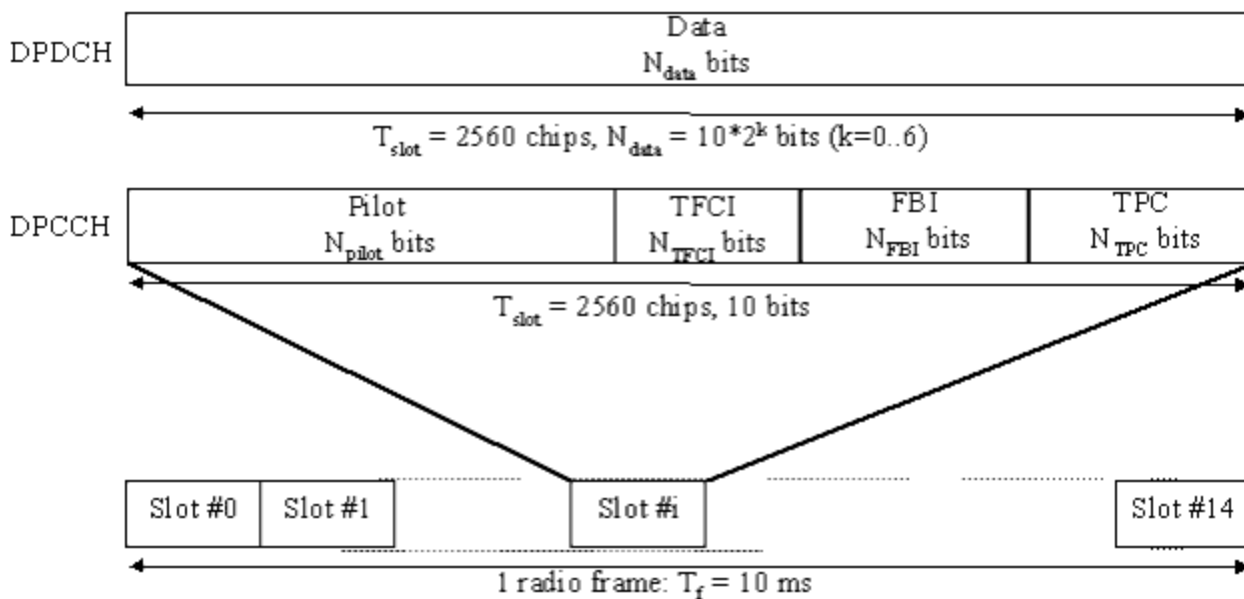

12.2 kbps Uplink Channel Frame Structure

Uplink 12.2 kbps Reference Measurement Channel, DPDCH Fields

Channel Bit Rate (kbps)	Channel Symbol Rate (ksps)	SF	Bits / Frame	Bits / Slot	Ndata
60	60	64	600	40	40

Advanced Design System 2008

Uplink 12.2 kbps Reference Measurement Channel, DPCCH Fields

Channel Bit Rate (kbps)	Channel Symbol Rate (ksps)	SF	Bits / Frame	Bits / Slot	Npilot	NTPC	NTFCI	NFBI
15	15	256	150	10	6	2	2	0

Uplink 768 kbps Reference Measurement Channel, Transport Channel Parameters

Parameter	DTCH	DCCH
Transport Channel Number	1	2
Transport Block Size	3840	100
Transport Block Set Size	7680	100
Transmission Time Interval	10 ms	40 ms
Type of Error Protection	Turbo Coding	Convolution Coding
Coding Rate	1/3	1/3
Rate Matching attribute	256	256
Size of CRC	16	12

Uplink 768 kbps Reference Measurement Channel, DPDCH Fields†

Channel Bit Rate (kbps)	Channel Symbol Rate (ksps)	SF	Bits / Frame	Bits / Slot	Ndata
960	960	4	9600	640	640

† There are two DPDCHs in uplink 768 kbps RMC.

Test Bench Basics

A template is provided for this test bench.

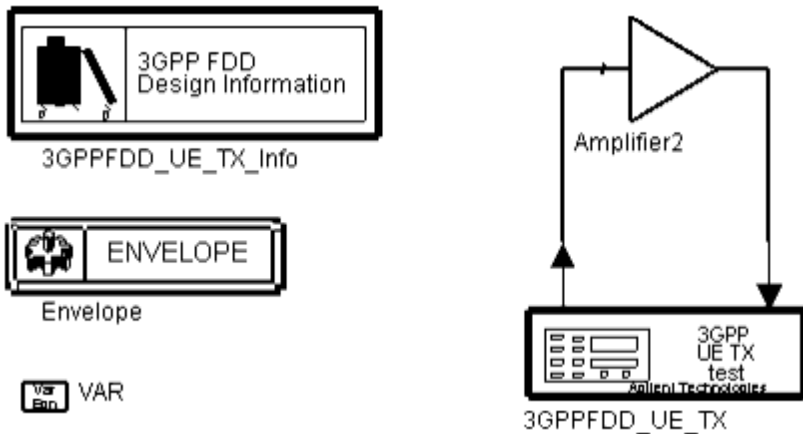

3GPPFDD User Equipment Transmitter Test Bench

To access the template:

1. In an Analog/RF schematic window select Insert > Template.
2. In the Insert > Template dialog box, choose 3GPPFDD_UE_TX_test, click OK; click left to place the template in the schematic window.

An example design using this template is available; from the ADS Main window click File > Example Project > WCDMA3G_RF_Verification_prj > 3GPPFDD_UE_TX_test .dsn.

The basics for using the test bench are:

- Connect to an RF DUT that is suitable for this test bench.
- CE_TimeStep, FSource, SourcePower, and FMeasurement parameter default values are typically accepted; if not, set values based on your requirements.
- Activate/deactivate measurement(s) based on your requirements.
- Run the simulation and view Data Display page(s) for your measurement(s).

For details, refer to [Test Bench Details](#).

Test Bench Details

The following sections provide details for setting up a test bench, setting measurement parameters for more control of the test bench, simulation measurement displays, and baseline performance.

Open and use the template:

1. In an Analog/RF schematic window select Insert > Template.
2. In the Insert > Template dialog box, choose 3GPPFDD_UE_TX_test, click OK; click left to place the template in the schematic window.

Test bench setup is detailed here.

1. Replace the DUT (Amplifier2 is provided with this template) with an RF DUT that is suitable for this test bench. For general information regarding using certain types of DUTs, see Appendix A, RF DUT Limitations.
2. Set the Required Parameters

 Note
Refer to [3GPPFDD_UE_TX](#) for a complete list of parameters for this test bench.

Generally, default values can be accepted; otherwise, values can be changed by the user as needed.

- Set CE_TimeStep.
Cosimulation occurs between the test bench (using Agilent ADS Ptolemy Data Flow simulation technology) and the DUT (using Circuit Envelope simulation technology). Each technology requires its own simulation time step with time-step coordination occurring in the interface between the technologies. CE_TimeStep defines the Circuit Envelope simulation time step to be used with this DUT. The CE_TimeStep must be set to a value equal to or a submultiple of (less than) WTB_TimeStep; otherwise, simulation will stop and an error message will be displayed.
The CE_TimeStep value is exported to the Choosing Analyses window in the Circuit Envelope Time Step field when the user clicks OK in the Wireless Test Bench Setup window.
Note that WTB_TimeStep is not user-settable. Its value is derived from other test bench parameter values; with default settings $WTB_TimeStep = 1/(3.84e6 \times 8)$ sec. The value is displayed in the Data Display pages as TimeStep.

$$WTB_TimeStep = 1/(ChipRate \times SamplesPerChip)$$

where

ChipRate is the non-settable value (3.84 MHz)

SamplesPerChip is the number of waveform sampling points during pulse forming.

- Set FSource, SourcePower, and FMeasurement.
 - FSource defines the RF frequency for the signal input to the RF DUT. The FSource value is exported to the Choosing Analyses window Fundamental Tones field when the user clicks OK in the Wireless Test Bench Setup window.
 - SourcePower defines the power level for FSource. SourcePower is defined as the average power during the non-idle time of the signal.
 - FMeasurement defines the RF frequency output from the DUT to be measured.
3. Activate/deactivate (YES / NO) test bench measurements (refer to [3GPPFDD_UE_TX](#)). At least one

measurement must be enabled.

4. More control of the test bench can be achieved by setting Basic Parameters, Signal Parameters, and parameters for each activated measurement. For details refer to [Parameter Settings](#).
5. The RF modulator (shown in the block diagram in [Transmitter Wireless Test Bench Block Diagram](#)) uses FSource, SourcePower (Required Parameters), MirrorSourceSpectrum (Basic Parameters), GainImbalance, PhaseImbalance, I OriginOffset, Q OriginOffset, and IQ Rotation (Signal Parameters).
The RF output resistance uses SourceR, SourceTemp, and EnableSourceNoise (Basic Parameters). The RF output signal source has a 50-ohm (default) output resistance defined by SourceR.
RF output (and input to the RF DUT) is at the frequency specified (FSource), with the specified source resistance (SourceR) and with power (SourcePower) delivered into a matched load of resistance SourceR. The RF signal has additive Gaussian noise power set by resistor temperature (SourceTemp) (when EnableSourceNoise=YES).
Note that the Meas_in point of the test bench provides a resistive load to the RF DUT set by the MeasR value (50-ohm default) (Basic Parameters).
The Meas signal contains linear and nonlinear signal distortions and time delays associated with the RF DUT input to output characteristics.
The TX DSP block (shown in the block diagram in [Transmitter Wireless Test Bench Block Diagram](#)) uses other Signal Parameters.
6. More control of Circuit Envelope analysis can be achieved by setting Envelope controller parameters. These settings include Enable Fast Cosim, which may speed the RF DUT simulation more than 10x. Setting these simulation options is described in Setting Fast Cosimulation Parameters and Setting Circuit Envelope Analysis Parameters in the Wireless Test Bench Simulation documentation.
7. To send the RF DUT output signal to an Agilent ESG RF signal generator, set parameters on the Signal to ESG tab.
For details, refer to [Signal to ESG Parameters](#).
8. To run a simulation, choose Simulation > Run in the Analog Design Environment main window.
For details, refer to R unning a Simulation in the Wireless Test Bench Simulation documentation.
9. Simulation results will appear in a Data Display window for each measurement. [Simulation Measurement Displays](#) describes results for each measurement available for this test bench.
For details on Viewing Results refer to the Wireless Test Bench Simulation documentation.

3GPPFDD_UE_TX

This section provides parameter information for Required Parameters, Basic Parameters, Signal Parameters, and parameters for the various measurements.

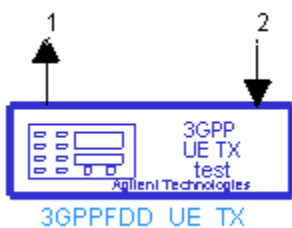

Description 3GPP FDD UE Tx test

Advanced Design System 2008

Library WTB
 Class TSDF3GPPFDD_UE_TX
 Derived From baseWTB_TX

Parameters

Name	Description	Default	Sym	Unit	Type	Range
RequiredParameters						
CE_TimeStep	Circuit envelope simulation time step	1/3.84 MHz/8		sec	real	(0, ∞)
WTB_TimeStep	Set CE_TimeStep < = 1/3.84e6/SamplesPerChip. SamplesPerChip is in Signal Parameters tab.					
FSource	Source carrier frequency	1950 MHz		Hz	real	(0, ∞)
SourcePower	Source power	dbmtow(-20.0)		W	real	[0, ∞)
FMeasurement	Measurement carrier frequency	1950 MHz		Hz	real	(0, ∞)
MeasurementInfo	Available Measurements Each measurement has parameters on its tab/category below.					
RF_EnvelopeMeasurement	Enable RF envelope measurement? NO, YES	YES			enum	
PowerMeasurement	Enable power measurement? NO, YES	NO			enum	
ACLR_Measurement	Enable ACLR	NO			enum	

Advanced Design System 2008

	measurement? NO, YES					
ACLR_ST_Measure	Enable ACLR switching transients measurement? NO, YES	NO			enum	
OccupiedBW_Measure	Enable occupied bandwidth measurement? NO, YES	NO			enum	
CDP_Measure	Enable code domain power measurement? NO, YES	NO			enum	
PCDE_Measure	Enable peak code domain error measurement? NO, YES	NO			enum	
EVM_Measure	Enable EVM measurement? NO, YES	NO			enum	
BasicParameters						
SourceR	Source resistance	50 Ohm		Ohm	real	(0, ∞)
SourceTemp	Source resistor temperature	-273.15		Celsius	real	[-273.15, ∞)
EnableSourceNoise	Enable source thermal noise? NO, YES	NO			enum	
MeasR	Measurement resistance	50 Ohm		Ohm	real	[10, 1.0e6]
MirrorSourceSpectrum	Mirror source spectrum about carrier? NO, YES	NO			enum	
MirrorMeasSpectrum	Mirror meas spectrum about carrier? NO, YES	NO			enum	

Advanced Design System 2008

RF_MirrorFreq	Mirror source frequency for spectrum/envelope measurement? NO, YES	NO			enum	
MeasMirrorFreq	Mirror meas frequency for spectrum/envelope measurement? NO, YES	NO			enum	
DUT_DelayBound	DUT delay bound	10.0 usec		sec	real	[0, (400.0/3840000)]
TestBenchSeed	Random number generator seed	1234567			int	[0, ∞)
SignalParameters						
GainImbalance	Gain imbalance, Q vs I	0.0		dB	real	(-∞, ∞)
PhaseImbalance	Phase imbalance, Q vs I	0.0		deg	real	(-∞, ∞)
I_OriginOffset	I origin offset (percent)	0.0			real	(-∞, ∞)
Q_OriginOffset	Q origin offset (percent)	0.0			real	(-∞, ∞)
IQ_Rotation	IQ rotation	0.0		deg	real	(-∞, ∞)
SamplesPerChip	Samples per chip	8	S		int	[2, 32]
RRC_FilterLength	RRC filter length (chips)	16			int	[2, 128]
SpecVersion	Secification version: Version 03_00, Version 12_00, Version 03_02	Version 12_00			enum	
SourceType	Source type: UL_12_2, UL_768	UL_12_2			enum	

Advanced Design System 2008

RF_EnvelopeMeasurementParameters						
RF_EnvelopeDisplayPages	RF envelope measurement display pages: 3GPPFDD_UE_TX_Envelope Figures					
RF_EnvelopeStart	RF envelope measurement start	0.0		sec	real	[0, ∞)
RF_EnvelopeStop	RF envelope measurement stop	(2560/3.84) usec		sec	real	(0, ∞)
RF_EnvelopeSlots	RF envelope measurement slots	1			int	[0, 100]
PowerMeasurementParameters						
PowerDisplayPages	Power measurement display pages: 3GPPFDD_UE_TX_Power Equations 3GPPFDD_UE_TX_Power Table 3GPPFDD_UE_TX_Power Figures					
PowerStartSlot	Start slot	0			int	[0, ∞)
PowerSlotsMeasured	Slots measured	1			int	[0, ∞)
ACLR_MeasurementParameters						
ACLR_DisplayPages	ACLR measurement display pages: 3GPPFDD_UE_TX_ACLR Equations 3GPPFDD_UE_TX_ACLR Table 3GPPFDD_UE_TX_ACLR Figures					
ACLR_Start	Measurement start	0.0		sec	real	[0, ∞)
ACLR_Stop	Measurement stop	(2560/3.84) usec		sec	real	(0, ∞)

Advanced Design System 2008

ACLR_Slots	Measurement slots	0			int	[0, 100]
ACLR_SpecMeasurementResolutionBandwidth	Resolution bandwidth	0		Hz	real	[0, ∞)
ACLR_SpecMeasurementWindow	Window type: ACLR_none, ACLR_Hamming 0.54, ACLR_Hanning 0.50, ACLR_Gaussian 0.75, ACLR_Kaiser 7.865, ACLR_8510 6.0, ACLR_Blackman, ACLR_Blackman-Harris	ACLR_none			enum	
ACLR_ST_MeasurementParameters						
ACLR_ST_DisplayPages	ACLR_ST measurement display pages: 3GPPFDD_UE_TX_ACLR_ST Table 3GPPFDD_UE_TX_ACLR_ST Equations					
ACLR_ST_Start	Measurement start	0.0		sec	real	[0, ∞)
ACLR_ST_Stop	Measurement stop	(2560/3.84) usec		sec	real	(0, ∞)
ACLR_ST_Slots	Measurement slots	0			int	[0, 100]
OccupiedBW_MeasurementParameters						
OBW_DisplayPages	Occupied BW measurement display pages: 3GPPFDD_UE_TX_OBW Equations 3GPPFDD_UE_TX_OBW Table 3GPPFDD_UE_TX_OBW Figures					
OBW_Start	Measurement	0.0		sec	real	[0, ∞)

Advanced Design System 2008

	start					
OBW_Stop	Measurement stop	(2560/3.84) usec		sec	real	(0, ∞)
OBW_Slots	Measurement slots	0			int	[0, 100]
OBW_SpecMeasResBW	Resolution bandwidth	0		Hz	real	[0, ∞)
OBW_SpecMeasWindow	Window type: OBW_none, OBW_Hamming 0.54, OBW_Hanning 0.50, OBW_Gaussian 0.75, OBW_Kaiser 7.865, OBW_8510 6.0, OBW_Blackman, OBW_Blackman-Harris	OBW_none			enum	
CDP_MeasurementParameters						
CDP_DisplayPages	CDP measurement display pages:					
CDP_StartSlot	Start slot	0			int	[0, ∞)
PCDE_MeasurementParameters						
PCDE_DisplayPages	PCDE measurement display pages: 3GPPFDD_UE_TX_PCDE Equations 3GPPFDD_UE_TX_PCDE Table 3GPPFDD_UE_TX_PCDE Figures					
PCDE_StartSlot	Start slot	0			int	[0, ∞)
EVM_MeasurementParameters						
EVM_DisplayPages	EVM measurement display pages: 3GPPFDD_UE_TX_EVM					

Advanced Design System 2008

	Equations 3GPPFDD_UE_TX_EVM Table					
EVM_Start	Measurement start	0.0		sec	real	[0, ∞)
EVM_SlotsMeasure	Slots to measure	1			int	[0, ∞)
SignalToESG_Parameters						
EnableESG	Enable signal to ESG? NO, YES	NO			enum	
ESG_Instrument	ESG instrument address	[GPIB0::19::INSTR][localhost][4790]			instrument	
ESG_Start	Signal start	0.0		sec	real	[0, ∞)
ESG_Stop	Signal stop	(2560/3.84) usec		sec	real	[(ESG_Start+60/3.84e6) (ESG_Start+32/3.84/S)
ESG_Slots	Slots to ESG	15			int	[0, 1000]
ESG_Power	ESG RF output power (dBm)	-20.0			real	(-∞, ∞)
ESG_ClkRef	Waveform clock reference: Internal, External	Internal			enum	
ESG_ExtClkRefFreq	External clock reference freq	10 MHz		Hz	real	(0, ∞)
ESG_IQFilter	IQ filter: through, filter_2100kHz, filter_40MHz	through			enum	
ESG_SampleClockRate	Sequencer sample clock rate	30.72 MHz		Hz	real	(0, ∞)
ESG_Filename	ESG waveform storage filename	3GPPFDD_UL			string	
ESG_AutoScaling	Activate auto scaling? NO, YES	YES			enum	

Advanced Design System 2008

ESG_ArbOn	Select waveform and turn ArbOn after download? NO, YES	YES			enum	
ESG_RFPowOn	Turn RF ON after download? NO, YES	YES			enum	
ESG_EventMarkerType	Event marker type: Neither, Event1, Event2, Both	Event1			enum	
ESG_MarkerLength	ESG marker length	10			int	[1, 60]

Pin Inputs

Pin	Name	Description	Signal Type
2	Meas_In	Test bench measurement RF input from RF circuit	timed

Pin Outputs

Pin	Name	Description	Signal Type
1	RF_Out	Test bench RF output to RF circuit	timed

Parameter Settings

More control of the test bench can be achieved by setting parameters on the Basic Parameters, Signal Parameters, and measurements categories for the activated measurements. Parameters for each category are described in the following sections.



Note

For required parameter information, see [Set the Required Parameters](#).

Basic Parameters

Advanced Design System 2008

1. SourceR is the RF output source resistance.
2. SourceTemp is the RF output source resistance temperature (oC) and sets noise density in the RF output signal to $(k(\text{SourceTemp}+273.15))$ Watts/Hz, where k is Boltzmann's constant.
3. EnableSourceNoise, when set to NO disables the SourceTemp and effectively sets it to -273.15oC (0 Kelvin). When set to YES, the noise density due to SourceTemp is enabled.
4. MeasR defines the load resistance for the RF DUT output Meas signal into the test bench. This resistance loads the RF DUT output; it is also the reference resistance for Meas signal power measurements.
5. MirrorSourceSpectrum is used to invert the polarity of the Q envelope of the generated RF signal before it is sent to the RF DUT. Depending on the configuration and number of mixers in an RF transmitter, the signal at the input of the DUT may need to be mirrored. If such an RF signal is desired, set this parameter to YES.
6. MirrorMeasSpectrum is used to invert the polarity of the Q envelope in the Meas_in RF signal input to the test bench (and output from the RF DUT). Depending on the configuration and number of mixers in the RF DUT, the signal at its output may be mirrored compared to the signal generated by the signal source (before any mirroring is done because of the MirrorSourceSpectrum setting). Proper demodulation and measurement of the RF DUT output signal requires that its RF envelope is not mirrored compared to the signal generated by the signal source (before any mirroring is done because of the MirrorSourceSpectrum setting). If the Meas_in RF signal is mirrored, set this parameter to YES. Proper setting of this parameter is required for measurements on the Meas_in signal in TX test benches (EVM, Constellation, CDP, PCDE) and results in measurement on a signal with no spectrum mirroring.
7. TestBenchSeed is an integer used to seed the random number generator used with the test bench. This value is used by all test bench random number generators, except those RF DUT components that use their own specific seed parameter. TestBenchSeed initializes the random number generation. The same seed value produces the same random results, thereby giving you predictable simulation results. To generate repeatable random output from simulation to simulation, use any positive seed value. If you want the output to be truly random, enter the seed value of 0.
8. RF_MirrorFreq is used to invert the polarity of the Q envelope in the RF_out RF signal for RF envelope, ppectrum, ACLR, and occupied bandwidth measurements. RF_MirrorFreq is typically set by the user to NO when MirrorSourceSpectrum = NO; RF_MirrorFreq is typically set by the user to YES when MirrorSourceSpectrum = YES. Both settings result in viewing the RF_out signal with no spectrum mirroring. Other settings by the user result in RF_out signal for RF_Envelope and Spectrum measurements with spectrum mirroring.
9. MeasMirrorFreq is used to invert the polarity of the Q envelope in the Meas_in RF signal for the RF envelope, spectrum, ACLR, and occupied bandwidth measurements. MeasMirrorFreq is typically set to NO by the user when the combination of the MirrorSourceSpectrum value and any signal mirroring in the users RF DUT results in no spectrum mirroring in the Meas_in signal. MeasMirrorFreq is typically set to YES by the user when the combination of the MirrorSourceSpectrum and RF DUT results in spectrum mirroring in the Meas_in signal. Other settings result in Meas_in signal for RF_Envelope and Spectrum measurements with spectrum mirroring. The MirrorMeasSpectrum parameter setting has no impact on the setting or use of the MeasMirrorFreq parameter.
10. DUT_DelayBound is used to transfer the DUT delay for measurement synchronization. For measurements of RF_out before the DUT, RF delay bound is calculated by adding the delays caused by RRC filters in modulation and measurements. For measurements of the RF DUT output (Meas_in), the Meas delay bound is calculated by adding the DUT_DelayBound to the RF delay bound.

Signal Parameters

1. GainImbalance, PhaseImbalance, I_OriginOffset, Q_OriginOffset, and IQ_Rotation are used to add certain

impairments to the ideal output RF signal. Impairments are added in the order described here. The unimpaired RF I and Q envelope voltages have gain and phase imbalance applied. The RF is given by:

$$V_{RF}(t) = A \left(V_I(t) \cos(\omega_c t) - g V_Q(t) \sin\left(\omega_c t + \frac{\Phi\pi}{180}\right) \right)$$

where A is a scaling factor that depends on the SourcePower and SourceR parameters specified by the user, V I (t) is the in-phase RF envelope, V Q (t) is the quadrature phase RF envelope, g is the gain imbalance

$$g = 10^{\frac{\text{GainImbalance}}{20}}$$

and, Φ (in degrees) is the phase imbalance.

Next, the signal V RF (t) is rotated by IQ_Rotation degrees. The I_OriginOffset and Q_OriginOffset are then applied to the rotated signal. Note that the amounts specified are percentages with respect to the output rms voltage. The output rms voltage is given by sqrt(2 × SourceR × SourcePower).

2. SamplesPerChip is used to set the number of samples in a chip. The default value is set to 8 to display settings according to the 3GPP standard. It can be set to a larger value for a simulation frequency bandwidth wider than 8 × 3.84 MHz. It can be set to a smaller value for faster simulation times; however, this will result in lower signal fidelity. If SamplesPerChip = 8, the simulation RF bandwidth is larger than the signal bandwidth by a factor of 8 (e.g., simulation RF bandwidth = 8 × 3.84 MHz).
3. RRC_FilterLength is used to set root raised-cosine filter length in chips. The default value is set to 16 to transmit a 3GPP FDD uplink signal in time and frequency domains based on the 3GPP standard [4]. It can be set to a smaller value for faster simulation times; however, this will result in lower signal fidelity. Better Adjacent Channel Leakage Ratio (ACLR) can be obtained using a longer filter length. Increasing RRC_FilterLength to 24 or 32 should result in a better ACLR. This may also correlate better to ACLR measurements when using instruments from Agilent Technologies.
4. SpecVersion is used to specify the 3GPP specification versions 2000-03, 2000-12 or 2002-03.
5. SourceType is used to specify the type of baseband signal. Reference measurement channels 12.2 and 768 kbps as defined in [4] and [5] are available. Basic parameters of these channels are listed in the following tables.

Uplink 12.2 kbps Reference Measurement Channel, Physical Parameters

Parameter	Unit	Level
Information bit rate	kbps	12.2
DPDCH	kbps	60
DPCCH	kbps	15
DPCCH Slot Format		0
DPCCH/DPDCH power ratio	dB	-5.46
TFCI		On

Advanced Design System 2008

Repetition	%	23
------------	---	----

Uplink 12.2 kbps Reference Measurement Channel, Transport Channel Parameters

Parameter	DTCH	DCCH
Transport Channel Number	1	2
Transport Block Size	244	100
Transport Block Set Size	244	100
Transmission Time Interval	20 ms	40 ms
Type of Error Protection	Convolution Coding	Convolution Coding
Coding Rate	1/3	1/3
Rate Matching attribute	256	256
Size of CRC	16	12

Uplink 768 kbps Reference Measurement Channel, Physical Parameters

Parameter	Unit	Level
Information bit rate	kbps	2*384
DPDCH1	kbps	960
DPDCH2	kbps	960
DPCCH	kbps	15
DPCCH Slot Format		0
DPCCH/DPDCH power ratio	dB	-11.48
TFCI		On
Puncturing	%	18

Uplink 768 kbps Reference Measurement Channel, Transport Channel Parameters

Parameter	DTCH	DCCH
Transport Channel Number	1	2
Transport Block Size	3840	100
Transport Block Set Size	7680	100
Transmission Time Interval	10 ms	40 ms
Type of Error Protection	Turbo Coding	Convolution Coding
Coding Rate	1/3	1/3

Rate Matching attribute	256	256
Size of CRC	16	12

RF Envelope Parameters

This measurement is not affected by the MirrorMeasSpectrum parameter. To apply spectrum mirroring to the measured RF_out signal, set RF_MirrorFreq = YES. To apply spectrum mirroring to the measured Meas_in signal, set MeasMirrorFreq = YES.

1. RF_EnvelopeDisplayPages provides Data Display page information for this measurement. It cannot be changed by the user.
2. RF_EnvelopeStart sets the start time for collecting input data.
3. RF_EnvelopeStop sets the stop time for collecting input data when RF_EnvelopeSlots = 0.
4. RF_EnvelopeSlots (when > 0) sets the number of slots over which data will be collected.

Depending on the values of RF_EnvelopeStart, RF_EnvelopeStop, and RF_EnvelopeSlots, the stop time may be adjusted.

For RF envelope measurement for both the RF_out and Meas_in signals:

Let:

$$\text{Start} = \text{TimeStep} * (\text{int}(\text{RF_EnvelopeStart}/\text{TimeStep}) + 0.5)$$

$$\text{Stop} = \text{TimeStep} * (\text{int}(\text{RF_EnvelopeStop}/\text{TimeStep}) + 0.5)$$

This means Start and Stop are forced to be an integer number of time-step intervals.

RF_EnvelopeSlots	Resultant Stop Time
0	Stop
> 0	Start + RF_EnvelopeSlots x SlotTime

For the RF envelope of Meas_in to contain at least one complete slot, the Stop value should be set to a minimum of SlotTime + (RF DUT time delay).

For information about TimeStep and SlotTime, see [Test Bench Variables for Data Displays](#).

Power Measurement Parameters

1. PowerDisplayPages provides Data Display page information for this measurement. It cannot be changed by the user.
2. PowerStartSlot sets the number of slots which should be ignored.
3. PowerSlotsMeasured sets the number of slots over which data will be collected.

The measurement start time is $\text{PowerStartSlot} \times \text{SlotTime}$. The measurement stop time is $(\text{PowerStartSlot} + \text{PowerSlotsMeasured}) \times \text{SlotTime}$. SlotTime is defined in [Test Bench Variables for Data Displays](#).

ACLR Measurement Parameters

The ACLR measurement is implemented by the spectrum measurement, which measures the RF signal spectrum in different frequency offsets. The ACLR can be calculated by analyzing the spectrum measurement in the data display file.

In the following, TimeStep denotes the simulation time step, and FMeasurement denotes the measured RF signal characterization frequency.

1. The measurement outputs the complex amplitude voltage values at the frequencies of the spectral tones. It does not output power at frequencies of the spectral tones. However, one can calculate and display the power spectrum as well as the magnitude and phase spectrum by using the dBm, mag, and phase functions of the data display window.
Note that the dBm function assumes a 50-ohm reference resistance; if a different measurement was used in the test bench, its value can be specified as a second argument to the dBm function, for example, dBm(SpecMeas, Meas_RefR) where SpecMeas is the instance name of the spectrum measurement and Meas_RefR is the resistive load used.
By default, the displayed spectrum extends from $F\text{Measurement} - 1/(2\text{TimeStep})$ Hz to $F\text{Measurement} + 1/(2\text{TimeStep})$ Hz. When $F\text{Measurement} < 1/(2\text{TimeStep})$, the default spectrum extends to negative frequencies. The spectral content at these negative frequencies is conjugated, mirrored, and added to the spectral content of the closest positive frequency. This way, the negative frequency tones are displayed on the positive frequency axis as would happen in an RF spectrum analyzer measurement instrument. This process may introduce an error in the displayed frequency for the mirrored tones. The absolute error introduced is less than $(\text{spectrum frequency step}) / 2$ (see the following table for the definition of spectrum frequency step).
The basis of the algorithm used by the spectrum measurement is the chirp-Z transform. The algorithm can use multiple slots and average the results to achieve video averaging (see note 6).
2. ACLR_DisplayPages provides Data Display page information for this measurement. It cannot be changed by the user.
3. ACLR_Start sets the start time for collecting input data.
4. ACLR_Stop sets the stop time for collecting input data when $\text{ACLR_Slots} = 0$ and $\text{ACLR_SpecMeasResBW} = 0$.
5. ACLR_Slots (when > 0) sets the number of slots over which data will be collected.
6. ACLR_SpecMeasResBW (when > 0) sets the resolution bandwidth of the spectrum measurement.
Depending on the values of ACLR_Stop, ACLR_Slots, and ACLR_SpecMeasResBW, the stop time may be adjusted and/or spectrum video averaging may occur. The different cases are explained in the following table.
Referring to the following table let:

$$\text{Start} = \text{TimeStep} \times \text{int}((\text{ACLR_Start}/\text{TimeStep}) + 0.5)$$

Advanced Design System 2008

$$\text{Stop} = \text{TimeStep} \times \text{int}((\text{ACLR_Stop}/\text{TimeStep}) + 0.5)$$

(This means Start and Stop are forced to be an integer number of time step intervals.)

X be the Normalized Equivalent Noise BW of the window used

Equivalent noise bandwidth (ENBW) compares the window to an ideal, rectangular filter. It is the equivalent width of a rectangular filter that passes the same amount of white noise as the window. The normalized ENBW is the ENBW multiplied by the time duration of the signal being windowed. See [Window Options and Normalized Equivalent Noise Bandwidth](#) for the normalized ENBW for the different window options available.

The Start and Stop times are used for both the RF_out and Meas_in signal spectrum analyses. The Meas_in signal is delayed in time from the RF_out signal by the value of the RF DUT time delay. Thus for RF DUT time delay > 0, the RF_out and Meas_in signal are inherently different and some spectrum display difference in the two is expected.

TimeStep and SlotTime are defined in [Test Bench Variables for Data Displays](#).

Effect of Different Values for ACLR_Stop, ACLR_Slots, and ACLR_SpecMeasResBW

Case 1	ACLR_Slots = 0 ACLR_SpecMeasResBW = 0 Resultant stop time = Stop Resultant resolution BW = X/(Stop - Start) Resultant spectrum frequency step = 1/(Stop-Start) Video averaging status = None
Case 2	ACLR_Slots > 0 ACLR_SpecMeasResBW = 0 Resultant stop time = Start + ACLR_Slots x SlotTime Notes: For ACLR_Slots > 0 and ACLR_SpecMeasResBW = 0 Video averaging occurs over all slot time intervals Resultant resolution BW = X/SlotTime Resultant spectrum frequency step = 1/SlotTime Video averaging status = Yes, when ACLR_Slots > 1
Case 3	ACLR_Slots = 0 ACLR_SpecMeasResBW > 0 Resultant stop time = Start + N*SlotTimeInterval where $N = \text{int}((\text{Stop} - \text{Start})/\text{SlotTimeInterval}) + 1$ For ACLR_Slots = 0 and ACLR_SpecMeasResBW > 0 Define SlotTimeInterval = TimeStep * $\text{int}((X/(\text{ACLR_SpecMeasResBW} * \text{TimeStep})) + 0.5)$

	<p>This means SlotTimeInterval is forced to a value that is an integer number of time step intervals. (Stop-Start) time is forced to be an integer number (N) of SlotTimeInterval N has a minimum value of 1 Video averaging occurs over all SlotTimeInterval The resolution bandwidth achieved is ResBW = X / SlotTimeInterval, which is very close to ACLR_SpecMeasResBW but may not be exactly the same if X/(ACLR_SpecMeasResBW*TimeStep) is not an exact integer.</p> <p>Resultant resolution BW = ResBW Resultant spectrum frequency step = ResBW Video averaging status = Yes when N > 1</p>
<p>Case 4</p>	<p>ACLR_Slots > 0 ACLR_SpecMeasResBW > 0 Resultant stop time = Start + M*SlotTimeInterval where $M = \text{int}((\text{ACLR_Slots} \times \text{SlotTime}) / \text{SlotTimeInterval}) + 1$</p> <p>For ACLR_Slots > 0 and ACLR_SpecMeasResBW > 0 Define SlotTimeInterval = TimeStep * $\text{int}((X / (\text{ACLR_SpecMeasResBW} * \text{TimeStep})) + 0.5)$ This means SlotTimeInterval is forced to a value that is an integer number of time step intervals. (Stop-Start) time is forced to be an integer number (M) of the SlotTimeInterval M has a minimum value of 1 Video averaging occurs over all SlotTimeIntervals The resolution bandwidth achieved is ResBW = X / SlotTimeInterval, which is very close to ACLR_SpecMeasResBW but may not be exactly the same if X/(ACLR_SpecMeasResBW*TimeStep) is not an exact integer.</p> <p>Resultant resolution BW = ResBW Resultant spectrum frequency step = ResBW Video averaging status = Yes, when M > 1</p>

- ACLR_SpecMeasWindow specifies the window that will be applied to each slot before its spectrum is calculated. Different windows have different properties, affect the resolution bandwidth achieved, and affect spectral shape. Windowing is often necessary in transform-based (chirp-Z, FFT) spectrum estimation in order to reduce spectral

distortion due to discontinuous or non-harmonic signal over the measurement time interval. Without windowing, the estimated spectrum may suffer from spectral leakage that can cause misleading measurements or masking of weak signal spectral detail by spurious artifacts.

The windowing of a signal in time has the effect of changing its power. The spectrum measurement compensates for this and the spectrum is normalized so that the power contained in it is the same as the power of the input signal.

Window Type Definitions:

- none

$$w(kT_s) = \begin{cases} 1.0 & 0 \leq k \leq N \\ 0.0 & \textit{otherwise} \end{cases}$$

where N is the window size

- Hamming 0.54

$$w(kT_s) = \begin{cases} 0.54 - 0.46 \cos\left(\frac{2\pi k}{N}\right) & 0 \leq k \leq N \\ 0.0 & \textit{otherwise} \end{cases}$$

where N is the window size

- Hanning 0.50

$$w(kT_s) = \begin{cases} 0.5 - 0.5 \cos\left(\frac{2\pi k}{N}\right) & 0 \leq k \leq N \\ 0.0 & \textit{otherwise} \end{cases}$$

where N is the window size

- Gaussian 0.75

$$w(kT_s) = \begin{cases} \exp\left(-\frac{1}{2}\left(0.75\frac{(2k-N)}{N}\right)^2\right) & 0 \leq \left|k - \frac{N}{2}\right| \leq \frac{N}{2} \\ 0.0 & \textit{otherwise} \end{cases}$$

where N is the window size

- Kaiser 7.865

$$w(kT_s) = \begin{cases} \frac{I_0\left(7.865\left[1 - \left(\frac{k-\alpha}{\alpha}\right)^2\right]^{1/2}\right)}{I_0(7.865)} & 0 \leq k \leq N \\ 0.0 & \textit{otherwise} \end{cases}$$

where N is the window size, $\alpha = N / 2$, and $I_0(\cdot)$ is the 0th order modified Bessel function of the first kind

- 8510 6.0 (Kaiser 6.0)

$$w(kT_s) = \begin{cases} \frac{I_0\left(6.0\left[1 - \left(\frac{k-\alpha}{\alpha}\right)^2\right]^{1/2}\right)}{I_0(6.0)} & 0 \leq k \leq N \\ 0.0 & \textit{otherwise} \end{cases}$$

where N is the window size, $\alpha = N / 2$, and $I_0(.)$ is the 0th order modified Bessel function of the first kind

- Blackman

$$w(kT_s) = \begin{cases} 0.42 - 0.5 \cos\left(\frac{2\pi k}{N}\right) + 0.08 \cos\left(\frac{4\pi k}{N}\right) & 0 \leq k \leq N \\ 0.0 & \textit{otherwise} \end{cases}$$

where N is the window size

- Blackman-Harris

$$w(kT_s) = \begin{cases} 0.35875 - 0.48829 \cos\left(\frac{2\pi k}{N}\right) + 0.14128 \cos\left(\frac{4\pi k}{N}\right) - 0.01168 \cos\left(\frac{6\pi k}{N}\right) & 0 \leq k \leq N \\ 0.0 & \textit{otherwise} \end{cases}$$

where N is the window size.

Window Options and Normalized Equivalent Noise Bandwidth

Window and Default Constant	NENBW
none	1
Hamming 0.54	1.363
Hanning 0.50	1.5
Gaussian 0.75	1.883
Kaiser 7.865	1.653
8510 6.0	1.467
Blackman	1.727
Blackman-Harris	2.021

ACLR due to Switching Transient Measurement Parameters

1. ACLR_ST_DisplayPages provides Data Display page information for this measurement. It cannot be changed by the user.
2. ACLR_ST_Start sets the start time for collecting input data.
3. ACLR_ST_Stop sets the stop time for collecting input data when ACLR_ST_Slots = 0.

4. ACLR_ST_Slots (when > 0) sets the number of slots over which data will be collected.

Depending on the values of ACLR_ST_Start, ACLR_ST_Stop, and ACLR_ST_Slots, the stop time may be adjusted.

For ACLR ST measurement for both the RF_out and Meas_in signals:

Let:

$$\text{Start} = \text{TimeStep} \times (\text{int}(\text{ACLR_ST_Start}/\text{TimeStep}) + 0.5)$$

$$\text{Stop} = \text{TimeStep} \times (\text{int}(\text{ACLR_ST_Stop}/\text{TimeStep}) + 0.5)$$

This means Start and Stop are forced to be an integer number of time-step intervals.

ACLR_ST_Slots	Resultant stop time
0	Stop
> 0	Start + ACLR_ST_Slots x SlotTime

For the ACLR ST of Meas_in to contain at least one complete slot, the Stop value should be set to a minimum of SlotTime + (RF DUT time delay).

For information about TimeStep and SlotTime, see [Test Bench Variables for Data Displays](#).

OBW Measurement Parameters

The occupied bandwidth measurement is implemented by the spectrum measurement which measures the spectrum of the input signal. The occupied bandwidth is calculated by analyzing the spectrum measured in data display files.

In the following notes, TimeStep denotes the simulation time step, and FMeasurement denotes the measured RF signal characterization frequency.

1. OBW_DisplayPages provides Data Display page information for this measurement. It cannot be changed by the user.
2. The measurement outputs the complex amplitude voltage values at spectral tone frequencies. Spectral tone frequency power is not output; however, power, magnitude, and phase spectrums can be calculated and displayed by using the dBm, mag, and phase functions of the data display window. Note that the dBm function assumes a 50-ohm measurement reference resistance; if a different reference resistance measurement is used in the test bench, its value can be specified as a second argument to the dBm function; for example, dBm(SpecMeas, Meas_RefR) where SpecMeas is the instance name of the spectrum measurement and Meas_RefR is the resistive load used.
By default, the displayed spectrum extends from FMeasurement - 1/(2TimeStep) Hz to FMeasurement + 1/(2TimeStep) Hz. When FMeasurement < 1/(2TimeStep), the default spectrum extends to negative frequencies. The spectral content at these negative frequencies is conjugated, mirrored, and added to the spectral content of the closest positive frequency. This way, the negative frequency tones are displayed on the positive frequency

Advanced Design System 2008

axis as would happen in an RF spectrum analyzer measurement instrument. This process may introduce an error in the displayed frequency for the mirrored tones. The absolute error introduced is less than (spectrum frequency step) / 2 (see the following table for the definition of spectrum frequency step).

The basis of the algorithm used by the spectrum measurement is the chirp-Z transform. The algorithm can use multiple slots and average the results to achieve video averaging (see note 8).

3. OBW_Start sets the start time for collecting input data.
4. OBW_Stop sets the stop time for collecting input data when OBW_Slots = 0 and OBW_SpecMeasResBW = 0.
5. OBW_Slots (when > 0) sets the number of slots over which data will be collected.
6. OBW_SpecMeasResBW (when > 0) sets the resolution bandwidth of the spectrum measurement.

Depending on the values of OBW_Stop, OBW_Slots, and OBW_SpecMeasResBW, the stop time may be adjusted and/or spectrum video averaging may occur. The different cases are explained in the following table.

Let:

$$\text{Start} = \text{TimeStep} \times \text{int}((\text{OBW_Start}/\text{TimeStep}) + 0.5)$$

$$\text{Stop} = \text{TimeStep} \times \text{int}((\text{OBW_Stop}/\text{TimeStep}) + 0.5)$$

(This means Start and Stop are forced to be an integer number of time step intervals.)

X be the Normalized Equivalent Noise BW of the window used

Equivalent noise bandwidth (ENBW) compares the window to an ideal, rectangular filter. It is the equivalent width of a rectangular filter that passes the same amount of white noise as the window. The normalized ENBW is the ENBW multiplied by the time duration of the signal being windowed. See [Window Options and NENBW](#) for the normalized ENBW for the different window options available.

Effect of Different Values for OBW_Stop, OBW_Slots, and OBW_SpecMeasResBW

Case 1	OBW_Slots = 0 OBW_SpecMeasResBW = 0 Resultant stop time = Stop Resultant resolution BW = X/(Stop - Start) Resultant spectrum frequency step = 1/(Stop-Start) Video averaging status = None
Case 2	OBW_Slots > 0 OBW_SpecMeasResBW = 0 Resultant stop time = Start + OBW_Slots x SlotTime For OBW_Slots > 0 and OBW_SpecMeasResBW = 0 Video averaging occurs over all slot time intervals Resultant resolution BW = X/SlotTime Resultant spectrum frequency step = 1/SlotTime Video averaging status = Yes, when OBW_Slots > 1
Case 3	OBW_Slots = 0 OBW_SpecMeasResBW > 0 Resultant stop time = Start + N*SlotTimeInterval

	<p>where $N = \text{int}((\text{Stop} - \text{Start}) / \text{SlotTimeInterval}) + 1$</p> <p>For $\text{OBW_Slots} = 0$ and $\text{OBW_SpecMeasResBW} > 0$ Define $\text{SlotTimeInterval} = \text{TimeStep} * \text{int}((X / (\text{OBW_SpecMeasResBW} * \text{TimeStep})) + 0.5)$ This means SlotTimeInterval is forced to a value that is an integer number of time step intervals. $(\text{Stop} - \text{Start})$ time is forced to be an integer number (N) of SlotTimeInterval N has a minimum value of 1 Video averaging occurs over all SlotTimeInterval The resolution bandwidth achieved is $\text{ResBW} = X / \text{SlotTimeInterval}$, which is very close to OBW_SpecMeasResBW but may not be exactly the same if $X / (\text{OBW_SpecMeasResBW} * \text{TimeStep})$ is not an exact integer.</p> <p>Resultant resolution BW = ResBW Resultant spectrum frequency step = ResBW Video averaging status = Yes when $N > 1$</p>
<p>Case 4</p>	<p>$\text{OBW_Slots} > 0$ $\text{OBW_SpecMeasResBW} > 0$ Resultant stop time = $\text{Start} + M * \text{SlotTimeInterval}$ where $M = \text{int}((\text{OBW_Slots} * \text{SlotTime}) / \text{SlotTimeInterval}) + 1$</p> <p>For $\text{OBW_Slots} > 0$ and $\text{OBW_SpecMeasResBW} > 0$ Define $\text{SlotTimeInterval} = \text{TimeStep} * \text{int}((X / (\text{OBW_SpecMeasResBW} * \text{TimeStep})) + 0.5)$ This means SlotTimeInterval is forced to a value that is an integer number of time step intervals. $(\text{Stop} - \text{Start})$ time is forced to be an integer number (M) of the SlotTimeInterval M has a minimum value of 1 Video averaging occurs over all SlotTimeInterval The resolution bandwidth achieved is $\text{ResBW} = X / \text{SlotTimeInterval}$, which is very close to OBW_SpecMeasResBW but may not be exactly the same if $X / (\text{OBW_SpecMeasResBW} * \text{TimeStep})$ is not an exact integer.</p> <p>Resultant resolution BW = ResBW Resultant spectrum frequency step = ResBW Video averaging status = Yes, when $M > 1$</p>

The Start and Stop times are used for both the RF_out and Meas_in signal spectrum analyses. The Meas_in signal is delayed in time from the RF_out signal by the value of the RF DUT time delay. Thus for RF DUT time delay greater than zero, the RF_out and Meas_in signal are inherently different and some spectrum display difference in the two is expected.

TimeStep and Slot_Time are defined in [Test Bench Variables for Data Displays](#)

7. OBW_SpecMeasWindow specifies the type of window. Different windows have different properties, affect the resolution bandwidth achieved, and affect spectral shape. The OBW_SpecMeasWindow is used to define the window that will be applied to each slot before its spectrum is calculated. Windowing is often necessary in transform-based (chirp-Z, FFT) spectrum estimation in order to reduce spectral distortion due to discontinuous or non-harmonic signal over the measurement time interval. Without windowing, the estimated spectrum may suffer from spectral leakage that can cause misleading measurements or masking of weak signal spectral detail by spurious artifacts.

Window Type Definitions:

- Hanning

$$w(k T_s) = \begin{cases} W - (1 - W) \cos\left(\frac{2\pi k}{NPoints}\right) & 0 \leq k \leq NPoints \\ 0.0 & otherwise \end{cases}$$

where W = WindowConstant

- Hamming

$$w(k T_s) = \begin{cases} W - (1 - W) \cos\left(\frac{2\pi k}{NPoints}\right) & 0 \leq k \leq NPoints \\ 0.0 & otherwise \end{cases}$$

where W = WindowConstant

- Blackman

$$w(k T_s) = \begin{cases} 0.42 - 0.5 \cos\left(\frac{2\pi k}{NPoints}\right) + 0.08 \cos\left(\frac{4\pi k}{NPoints}\right) & 0 \leq k \leq NPoints \\ 0.0 & otherwise \end{cases}$$

- Kaiser (Kaiser-Bessel)

$$w(k T_s) = \begin{cases} \frac{I_0\left(\beta \left[1 - \left(\frac{k - \alpha}{\alpha}\right)^2\right]^{1/2}\right)}{I_0(\beta)} & 0 \leq k \leq NPoints \\ 0.0 & otherwise \end{cases}$$

Here $\alpha = NPoints / 2$, β is the shape parameter (set by WindowConstant), and $I_0(.)$ is the 0th order modified Bessel function of the first kind.

- Gaussian (Weierstrass)

$$w(kT_s) = \begin{cases} \exp\left(-\frac{1}{2}\left(\alpha \frac{(2k - NPoints)}{NPoints}\right)^2\right) & 0 \leq \left|k - \frac{NPoints}{2}\right| \leq \frac{NPoints}{2} \\ 0.0 & otherwise \end{cases}$$

where α = WindowConstant.

Window Options and NENBW

Window and Default Constant	Normalized Equivalent Noise BW (X)
None	1
Hamming 0.54	Not defined (1 is used)
Hanning 0.50	1.5
Gaussian 0.75	2.215
Kaiser 7.865	Not defined (1 is used)
8510 6.0	Not defined (1 is used)
Blackman	Not defined (1 is used)
Blackman-Harris	Not defined (1 is used)

The windowing of a signal in time has the effect of changing its power. The spectrum measurement compensates for this and the spectrum is normalized so that the power contained in it is the same as the power of the input signal.

CDP Measurement Parameters

1. CDP_DisplayPages provides Data Display page information for this measurement. It cannot be changed by the user.
2. CDP_StartSlot sets the starting slot from which slot data will be collected. The CDP_StartSlot is used for both the RF_out and Meas_in CDP analyses.

The measurement interval is one timeslot. The length of time that data will be collected is SlotTime. See [Test Bench Equations Derived from Test Bench Parameters and Exported to the Data Display](#).

PCDE Measurement Parameters

1. PCDE_DisplayPages provides Data Display page information for this measurement. It cannot be changed by the user.
2. PCDE_StartSlot sets the starting slot from which slot data will be collected. PCDE_StartSlot is used for both

RF_out and Meas_in PCDE analyses.

The measurement interval is one timeslot. The length of time that data will be collected is SlotTime. See [Test Bench Equations Derived from Test Bench Parameters and Exported to the Data Display](#).

EVM Parameters

1. EVM_DisplayPages provides Data Display page information for this measurement. It cannot be changed by the user.
2. EVM_Start specifies starting time instant for the measurement. EVM_Start time is used for RF_out and Meas_in EVM analyses. The Meas_in signal is delayed in time from the RF_out signal by the RF DUT time delay value. Thus for RF DUT time delay >0, RF_out and Meas_in signals are inherently different and some EVM difference in the two is expected even if the RF DUT does not introduce any distortion other than time delay.
3. EVM_SlotsMeasured specifies the measurement interval. The time length of data to be collected is EVM_SlotMeasured × SlotTime. See [Test Bench Equations Derived from Test Bench Parameters and Exported to the Data Display](#).

Signal to ESG Parameters

The EVM measurement collects data from the Meas_in signal and downloads it to an Agilent E4438C Vector Signal Generator. This measurement uses Connection Manager architecture to communicate with the instrument; parameters specify how data is interpreted.

Prerequisites for using the Signal to ESG option are:

- ESG Vector Signal Generator E4438C; for information, visit the web site <http://www.agilent.com/find/esg>.
- PC workstation running an instance of the connection manager server.
- Supported method of connecting the instrument to your computer through the Connection Manager architecture; for information, see Connection Manager.

Parameter Information

1. EnableESG specifies if the signal is downloaded to the ESG instrument. If set to NO, no attempt will be made to communicate with the instrument.
2. ESG_Instrument specifies a triplet that identifies the VSA resource of the instrument to be used in the simulation, the connection manager server hostname (defaults to localhost), and the port at which the connection manager server listens for incoming requests (defaults to 4790). To ensure that this field is populated correctly, click Select Instrument, enter the server hostname and port, click OK to see the Remote Instrument Explorer dialog, select a VSA resource identifier, and click OK. For details about selecting instruments, see Instrument Discovery in the Wireless Test Bench Simulation documentation.

3. ESG_Start and ESG_Stop (when ESG_Slots=0) specify when to start and stop data collection. The number of samples collected, $ESG_Stop - ESG_Start + 1$, must be in the range 60 samples to 64 Msamples, where 1 Msample = 1,048,576 samples. The ESG requires an even number of samples; the last sample will be discarded if $ESG_Stop - ESG_Start + 1$ is odd.
4. ESG_Slots sets the number of slots over which data will be collected. When $ESG_Slots > 0$, ESG_Stop is forced to $ESG_Start + ESG_Slots \times SlotTime$ (where SlotTime is 5 msec).
5. ESG_ClkRef specifies an internal or external reference for the ESG clock generator. If set to External, the ESG_ExtClkRefFreq parameter sets the frequency of this clock.
6. ESG_IQFilter specifies the cutoff frequency for the reconstruction filter that lies between the DAC output and the Dual Arbitrary Waveform Generator output inside the ESG.
7. ESG_SampleClkRate sets the sample clock rate for the DAC output.
8. ESG_FileName sets the name of the waveform inside the ESG that will hold the downloaded data.
9. The ESG driver expects data in the range $\{-1, 1\}$. ESG_AutoScaling specifies whether to scale inputs to fit this range. If set to YES, inputs are scaled to the range $\{-1, 1\}$; if set to NO, raw simulation data is downloaded to the ESG without any scaling, but data outside the range $\{-1, 1\}$ is clipped to -1 or 1. If set to YES, scaling is also applied to data written to the local file (ESG_FileName setting).
10. If ESG_ArbOn is set to YES, the ESG will start generating the signal immediately after simulation data is downloaded; if set to NO, waveform generation must be turned on at the ESG front panel.
11. If ESG_RFPOwOn is set to YES, the ESG will turn RF power on immediately after simulation data is downloaded. If ESG_RFPOwOn is set to NO (default), RF power must be turned on at the ESG front panel.
12. ESG_EventMarkerType specifies which ESG Event markers are enabled: Event1, Event2, Both, or Neither. Event markers are used for synchronizing other instruments to the ESG. When one or both EventMarkers are enabled, Event1 and/or Event2 is set beginning from the first sample of the downloaded Arb waveform over the range of points specified by the ESG_MarkerLength parameter. This is equivalent to setting the corresponding event from the front panel of the ESG.
13. ESG_MarkerLength specifies the range of points over which the markers must be set starting from the first point of the waveform. Depending on the setting of ESG_EventMarkerType, the length of trigger Event1 or Event2 (or both) is set to a multiple of the pulsewidth that, in turn, is determined by the sample clock rate of the DAC output.

Simulation Measurement Displays

After running the simulation, results are displayed in the Data Display pages for each measurement activated.

 Note
Measurement results from a wireless test bench have associated names that can be used in Data Display Expressions. For more information, refer to [Measurement Results for Expressions for 3GPP FDD Wireless Test Benches](#).

RF Envelope Measurement

The RF Envelope measurement (not defined in 3GPP specifications) shows the time envelope of the 3GPP FDD RF signal. Two kinds of signals are tested: the RF signal which does not go through the DUT, and the Meas signal which does go through the DUT and may contain a few microseconds of delay, some noise, and nonlinearity.

Measurement results are shown in the following figure. Tables at the top of the data display page show some basic measurement parameters. The waveforms show the envelopes of the RF and Meas signals. Two markers identify the start points of the stable signals. An equation for Delay is defined to calculate the difference in time domain between the two markers. The value of Delay is displayed in a table to indicate the delay caused by the DUT.

real(RF_FSource)/(1 MHz)	real(RF_Power_dBm)	real(RF_R)	
1950.000	24.000	50.000	
real(Meas_FMeasurement)/(1MHz)		real(Meas_RefR)	
1950.000		50.000	
real(ChipRate)/(1 MHz)	real(ChipsPerSlot)	real(SlotTime)/(1 usec)	real(FrameTime)/(1 msec)
3.840	2560.000	666.667	10.000

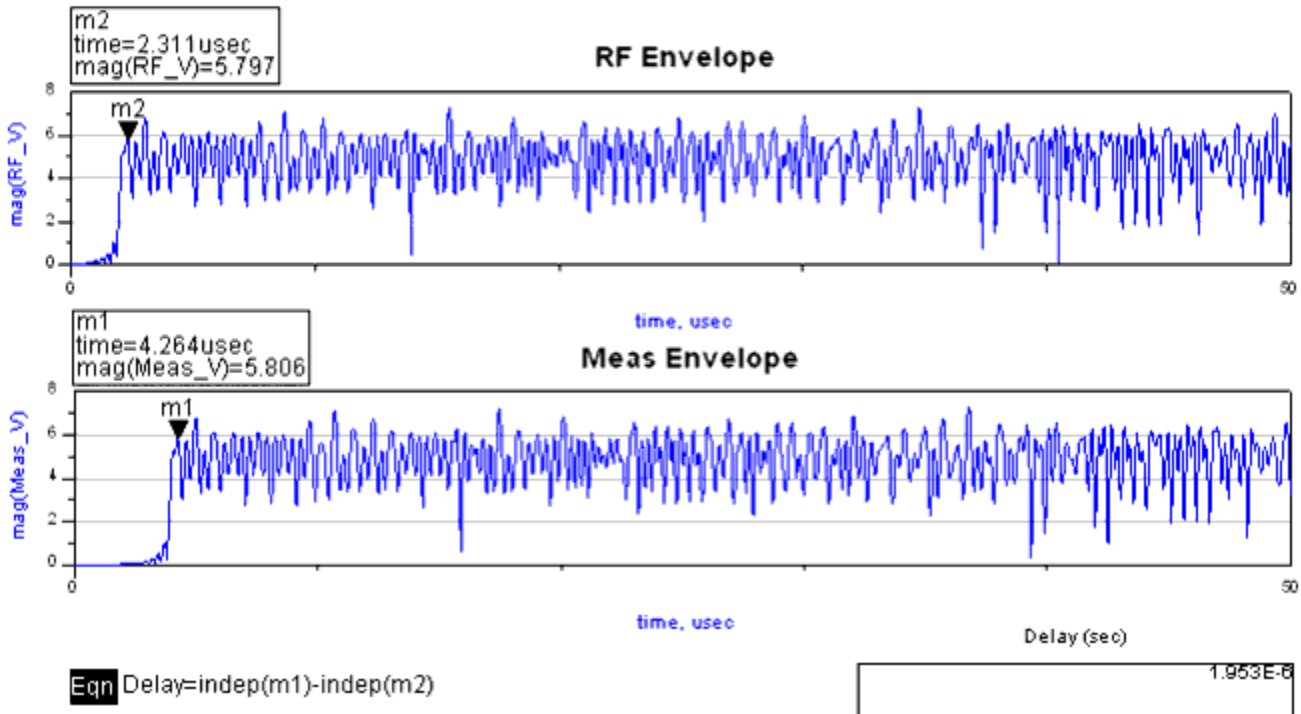

RF Envelope Measurement Results

Power Measurement

The power measurement measures the CCDF (complementary cumulative distribution function) curves of the transmitter (CCDF is not defined in 3GPP specifications). The CCDF and the peak-to-average ratio is calculated for the 3GPP FDD RF signal.

Two kinds of signals are tested: the RF signal which does not go through the DUT; and, the Meas signal which does go

through the DUT and may contain a few microseconds of delay, some noise, and nonlinearity.

The data display contains three pages. The following figure shows peak power, mean power and peak-to-mean ratio of RF and Meas signals.

real(RF_FSource)/(1 MHz)	real(RF_Power_dBm)	real(RF_R)
1950.000	24.000	50.000

real(Meas_FMeasurement)/(1MHz)	real(Meas_RefR)
1950.000	50.000

RF Power Measurement

RF_Peak_to_Mean_dB	RF_Power.CCDF.MeanPower_dBm	RF_Power.CCDF.PeakPower_dBm
3.153	23.994	27.147

Meas Power Measurement

Peak_to_Mean_dB	Meas_Power.CCDF.MeanPower_dBm	Meas_Power.CCDF.PeakPower_dBm
3.128	23.993	27.121

RF and Meas Signal Power Ratios

The following figure shows two CCDF curves of RF and Meas signals. The 3GPPFDD_UE_TX_Power Equations page includes two equations that are defined to calculate peak-to-mean ratio of the RF and Meas signals.

real(RF_FSource)(1 MHz)	real(RF_Power_dBm)	real(RF_R)
1950.000	24.000	50.000
real(Meas_FMeasurement)(1MHz)		real(Meas_RefR)
1950.000		50.000

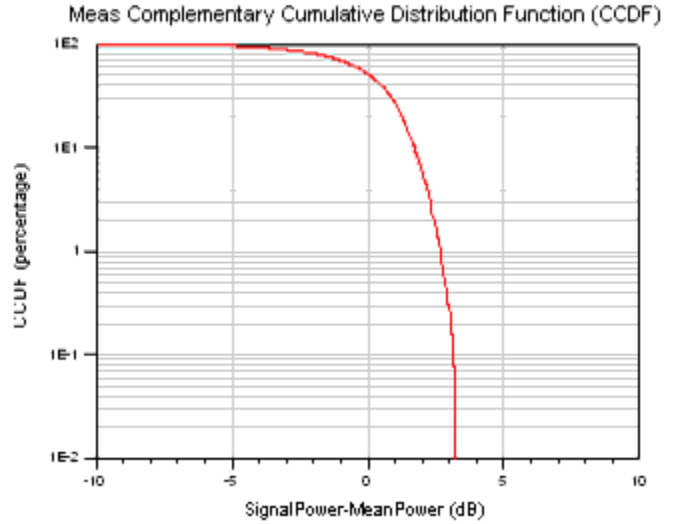
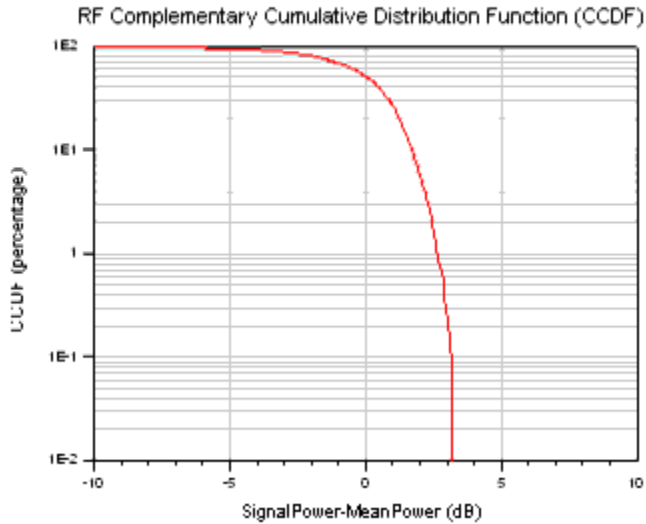

CCDF Curves

ACLR Measurement

This measurement is used to test adjacent channel leakage power ratio (ACLR) defined in 3GPP TS 25.101, section 6.6.2.2.

ACLR is the ratio of the RRC filtered mean power centered on the assigned channel frequency to the RRC filtered mean power centered on an adjacent channel frequency. Two kinds of signals are tested: the RF signal which does not go through the DUT; and, the Meas signal which does go through DUT and may contain a few of microseconds of delay, some noise and nonlinearity.

In the data display, measurement results are automatically compared with pass/fail criteria defined in 3GPP TS 25.101, table 6.11. The comparison results are displayed on the 3GPPFDD_UE_TX_ACLR Table page (the following figure).

The data display contains three pages. The 3GPPFDD_UE_TX_ACLR Table page (the following figure) shows adjacent channel power and adjacent power ratio of the RF and Meas signals.

real(RF_FSource)/(1 MHz)	real(RF_Power_dBm)	real(RF_R)
1950.000	24.000	50.000

real(Meas_FMeasurement)/(1MHz)	real(Meas_RefR)
1950.000	50.000

RF Main, Upper, and Lower Channel Powers (dBm)

RF_Main_Ch_Pwr	RF_U10_Ch_Pwr	RF_U5_Ch_Pwr	RF_L5_Ch_Pwr	RF_L10_Ch_Pwr
23.738	-40.597	-31.134	-31.385	-40.699

RF ACLR (dB)

RF_ACLR_U10	RF_ACLR_U5	RF_ACLR_L5	RF_ACLR_L10
54.335	54.872	55.123	54.437

Meas Main, Upper, and Lower Channel Powers (dBm)

Main_Ch_Pwr	U10_Ch_Pwr	U5_Ch_Pwr	L5_Ch_Pwr	L10_Ch_Pwr
23.737	-43.192	-31.257	-31.511	-43.254

Meas ACLR (dB)

ACLR_U10	ACLR_U5	ACLR_L5	ACLR_L10
65.929	54.994	55.248	67.001

3GPP Specification TS 25.101 (2000-12) Section 6.6.2.2

Specification requirements

Test Results

+5 MHz or -5 MHz 33 dB
 +10 MHz or -10 MHz 43 dB

Passed

ACLR Measurement Results

The 3GPPFDD_UE_TX_ACLR Figures page (the following figure) shows the spectrum of the main channel and adjacent channels of the RF and Meas signals. The 3GPPFDD_UE_TX_ACLR Equations page includes several equations that are defined to calculate adjacent channel power and adjacent channel power ratio of the RF and Meas signals.

real(RF_FSourceY(1 MHz))	real(RF_Power_dBm)	real(RF_R)
1950.000	24.000	50.000
real(Meas_FMeasurementY(1MHz))		real(Meas_RefR)
1950.000		50.000

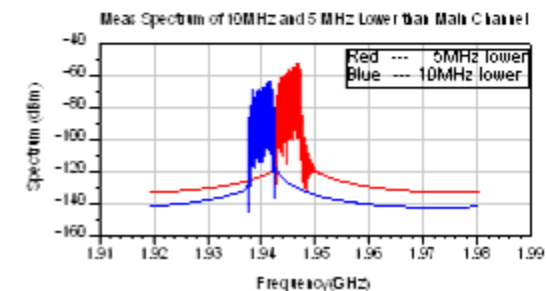
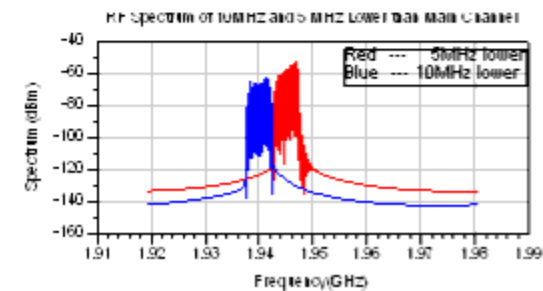
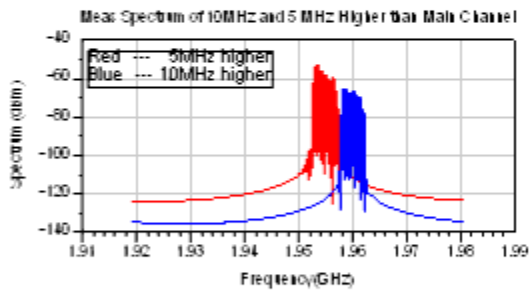
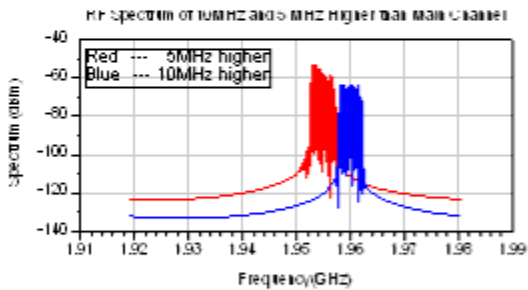
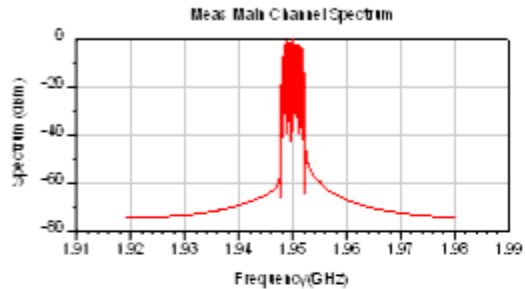
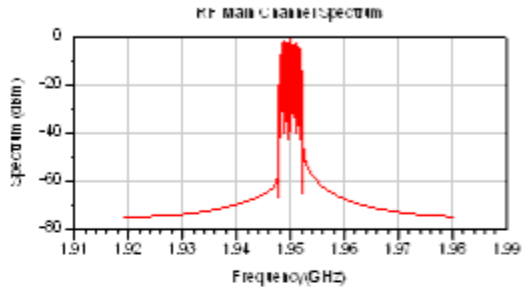

ACLR Spectrums

ACLR Due to Switching Transient Measurement

This ACLR_ST measurement is used to test adjacent channel leakage power ratio (ACLR) in the presence of switching transients, defined in 3GPP TS 25.101, section 6.6.2.2, Note 1.

ACLR is the ratio of the RRC filtered mean power centered on the assigned channel frequency to the RRC filtered mean power centered on an adjacent channel frequency. Two kinds of signal are tested: the RF signal which does not go through the DUT; and, the Meas signal which does go through the DUT and may contain a few microseconds of delay, some noise, and nonlinearity.

Advanced Design System 2008

In the data display, the measurement results are automatically compared with pass/fail criteria defined in 3GPP TS 25.101, table 6.11, and the comparison results are displayed on the 3GPPFDD_UE_TX_ACLR_ST Table page (the following figure).

The data display contains two pages. The 3GPPFDD_UE_TX_ACLR_ST Table page (the following figure) shows adjacent channel power and adjacent power ratio of the RF and Meas signals. The 3GPPFDD_UE_TX_ACLR_ST Equations page includes several equations that are defined to calculate adjacent channel power and adjacent channel power ratio of the RF and Meas signals.

real(RF_FSource)(1 MHz)	real(RF_Power_dBm)	real(RF_R)
1950.000	24.000	50.000
real(Meas_FMeasurement)(1MHz)		real(Meas_RefR)
1950.000		50.000

RF Average Power (dBm)

SlotIndex	RF_L10_Ch_Power	RF_L5_Ch_Power	RF_Main_Ch_Power	RF_U5_Ch_Power	RF_U10_Ch_Power
0	-40.699	-31.385	23.738	-31.134	-40.597

RF ACLR (dB)

SlotIndex	RF_ACLR_L10	RF_ACLR_L5	RF_ACLR_U5	RF_ACLR_U10
0	64.437	65.123	64.872	64.336

Meas Average Power (dBm)

SlotIndex	L10_Ch_Power	L5_Ch_Power	Main_Ch_Power	U5_Ch_Power	U10_Ch_Power
0	-43.264	-31.511	23.737	-31.257	-43.192

Meas ACLR (dB)

SlotIndex	ACLR_L10	ACLR_L5	ACLR_U5	ACLR_U10
0	67.001	65.248	64.994	65.929

3GPP Specification TS 25.101 (2000-12) section 6.6.2.2

Specification Requirements

+5 MHz or -5 MHz	33 dB
+10 MHz or -10 MHz	43 dB

Test Result

0 Passed Caution, ACP greater than -50dBm

ACL_R_ Measurement Results

Occupied Bandwidth Measurement

The occupied bandwidth (OBW) measurement is defined in 3GPP TS 25.104, section 6.6.1. OBW is a measure of the bandwidth containing 99% of the total integrated power for transmitted spectrum and is centered on the assigned channel frequency. The occupied channel bandwidth must be less than 5 MHz based on a chip rate of 3.84 Mcps.

Two kinds of signals are tested: the RF signal which does not go through the DUT; and, the Meas signal which does go through the DUT and may contain a few microseconds of delay, some noise, and nonlinearity.

Advanced Design System 2008

In the data display, measurement results are automatically compared with pass/fail criteria defined in 3GPP TS 25.101, section 6.6.1, and the comparison results are displayed on 3GPPFDD_UE_TX_OBW Table page (the following figure).

At the top of each page, an identical table contains basic measurement parameters. The 3GPPFDD_UE_TX_OBW Table page (the following figure) shows the resolution bandwidth and the occupied bandwidth of the RF and Meas signals. Adjust the markers using the keyboard arrow keys until the Lower Side and the Higher Side power ratio equals 0.5%. The 3GPPFDD_UE_TX_OBW Table page (the following figure) shows the equations used to calculate the occupied bandwidth, and the criteria used to determine if the results pass or not.

$\text{real}(\text{RF_FSource})/(1 \text{ MHz})$	$\text{real}(\text{RF_Power_dBm})$	$\text{real}(\text{RF_R})$
1950.000	24.000	50.000
$\text{real}(\text{Meas_FMeasurement})/(1 \text{ MHz})$		$\text{real}(\text{Meas_RefR})$
1950.000		50.000

RF Occupied Bandwidth

$\text{RF_Occupied_BW_MHz}$	$\text{RF_Resolution_BandWidth_kHz}$
4.155	1.500
$\text{RF_Lower_Side_percentage}$	$\text{RF_Higher_Side_percentage}$
0.496	0.492
RF_Total_Power_W	
0.251	

Meas Occupied Bandwidth

$\text{Meas_Occupied_BW_MHz}$	$\text{Meas_Resolution_BandWidth_kHz}$
4.155	1.500
$\text{Meas_Lower_Side_percentage}$	$\text{Meas_Higher_Side_percentage}$
0.496	0.492
$\text{Meas_Total_Power_W}$	
0.251	

3GPP Specification TS 25.101(2000-12) section 6.6.1

Specification requirements

Test results

The occupied channel bandwidth shall be less than 50 kHz base on a chip rate of 3.84 Mcps.

Passed

Occupied Bandwidth Measurement Results

The 3GPPFDD_UE_TX_OBW Figures page (the following figure) shows the spectrum of the RF and Meas signals with two markers placed on each spectrum.

real(RF_FCoilRe)/(1 MHz)	real(RF_Power_dBm)	real(RF_P)
1950.000	21.000	50.000
real(Meas_FMeasFremtr)/(1 MHz)	real(Meas_PeRF)	
1950.000	50.000	

RF Spectrum with Maximum Power

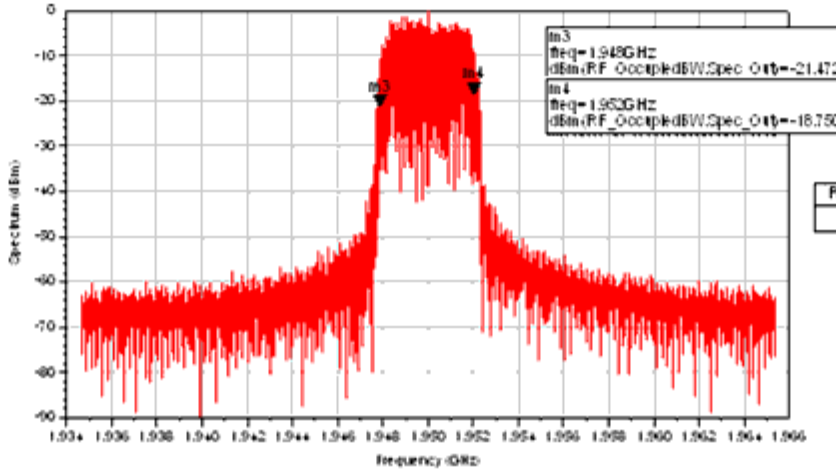

RF_Lower_Side_percentage
0.496

RF_Higher_Side_percentage
0.496

Meas Spectrum with Maximum Power

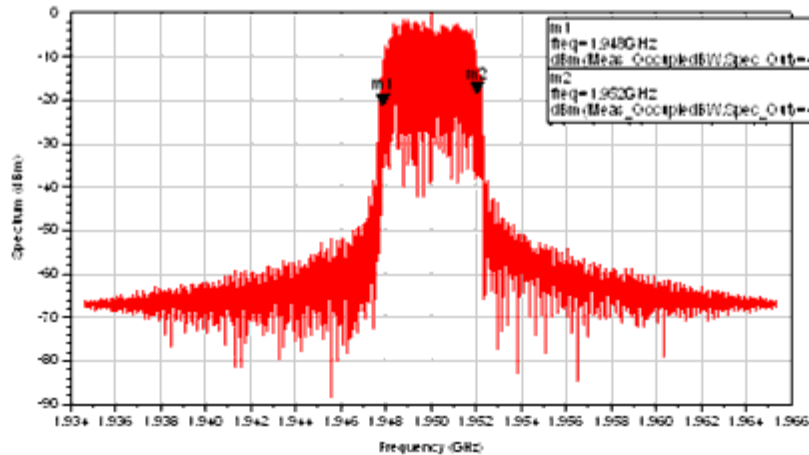

Meas_Lower_Side_percentage
0.496

Meas_Higher_Side_percentage
0.496

Move markers with up/down arrow keys until the Lower Side and Higher Side power ratio equals to 0.5%. The Occupied_BW will then display the resulting bandwidth containing 99% of the transmitted power.

Occupied Bandwidth Signal Spectrums

CDP Measurement

Code domain power (CDP) is a measure of power distribution on code domain (not defined in the 3GPP specifications).

The CDP is calculated by projecting the power onto the code domain at a specified spread factor (256). The CDP for every code in the domain is defined as the ratio of the mean power of the projection onto that code, to the mean power of the composite reference waveform. The measurement interval is one timeslot. Two kinds of signals are tested: the RF signal which does not go through the DUT, and the Meas signal which does go through the DUT and

may contain a few microseconds of delay, some noise, and nonlinearity.

Results are shown in the following figure.

real(RF_FSource)/(1 MHz)	real(RF_Power_dBm)	real(RF_R)
1950.000	24.000	50.000
real(Meas_FMeasurement)/(1MHz)	real(Meas_RefR)	
1950.000	50.000	

RF Code Domain Power

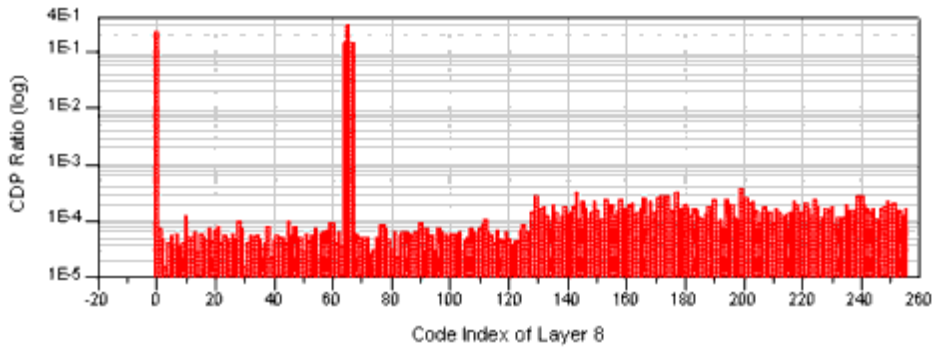

Meas Code Domain Power

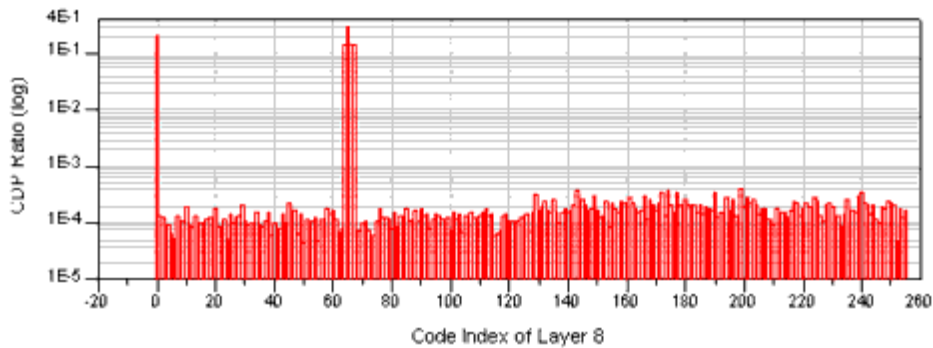

CDP Measurement Results

PCDE Measurement

This measurement is used to test peak code domain error (PCDE) defined in 3GPP TS 25.101, section 6.8.3.

PCDE is calculated by projecting the power of the error vector onto the code domain at a specified spread factor. The code domain error for every code in the domain is defined as the ratio of the mean power of the projection onto that code, to the mean power of the composite reference waveform. This ratio is expressed in dB. The PCDE is defined as the maximum value for the code domain error for all codes. The measurement interval is one timeslot. Two kinds of

signals are tested: the RF signal which does not go through the DUT, and the Meas signal which does go through the DUT and may contain a few microseconds of delay, some noise and nonlinearity.

In the data display, the measurement results are compared automatically with pass/fail criteria defined in 3GPP TS 25.101, section 6.8.3.1. Comparison results are displayed on the 3GPPFDD_UE_TX_PCDE Table page (the following figure).

The data display contains three pages. The 3GPPFDD_UE_TX_PCDE Table page (the following figure) shows the peak code domain error of the RF and Meas signals.

real(RF_FSource)/(1 MHz)	real(RF_Power_dBm)	real(RF_R)
1950.000	24.000	50.000
real(Meas_FMeasurement)/(1MHz)		real(Meas_RefR)
1950.000		50.000

RF Peak Code Domain Error

Meas Peak Code Domain Error

RF_Q_Ch_Peak_Code_Domain_Error_dB	-266.861
RF_I_Ch_Peak_Code_Domain_Error_dB	-265.392

Q_Ch_Peak_Code_Domain_Error_dB	-58.416
I_Ch_Peak_Code_Domain_Error_dB	-62.131

3GPP Specification TS 25.101(2000-12) section 6.8.3

Specification Requirements

Test results

The Peak Code Domain Error shall not exceed -15 dB

Passed

PCDE Measurement Results

The 3GPPFDD_UE_TX_PCDE Figures page (the following figure) shows the code domain error of the RF and Meas signals; markers indicate the peak values. The 3GPPFDD_UE_TX_PCDE Equations page shows the equations used to calculate peak code domain error, and the criteria used to determine if the results pass or not.

real:RF_FSource(V) [MHz]	real:RF_Power(dBm)	real:RF_R
1950.000	24.000	50.000
real:Meas_FMeasurement(V) [MHz]		real:Meas_RetP
1950.000		50.000

RF Peak Code Domain Error

Meas Peak Code Domain Error

m1
3GPPFDD_UE_TX_RF_PCDECodeDomainBrCDE_CodeInle=0.000
ploLss(10*log10(RF_PCDECodeDomainBrCDE_RF_PCDECodeDomainBrCDE_CodeInle)=-266.86)

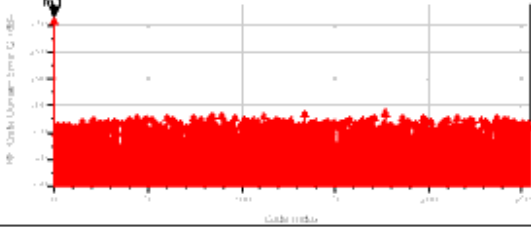

m3
3GPPFDD_UE_TX_Meas_PCDECodeDomainBrCDE_CodeInle=63.000
ploLss(10*log10(Meas_PCDECodeDomainBrCDE_Meas_PCDECodeDomainBrCDE_CodeInle)=-65.748)

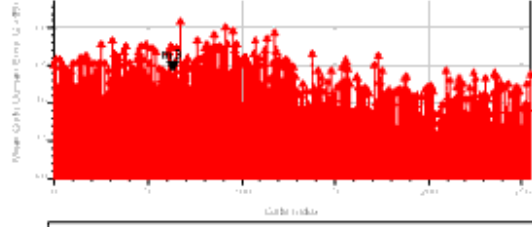

m2
3GPPFDD_UE_TX_RF_PCDECodeDomainBrCDE_CodeInle=125.000
ploLss(10*log10(RF_PCDECodeDomainBrCDE_RF_PCDECodeDomainBrCDE_CodeInle)=-304.18)

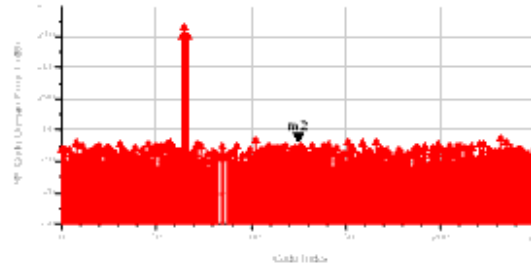

m4
3GPPFDD_UE_TX_Meas_PCDECodeDomainBrCDE_CodeInle=52.000
ploLss(10*log10(Meas_PCDECodeDomainBrCDE_Meas_PCDECodeDomainBrCDE_CodeInle)=-70.49)

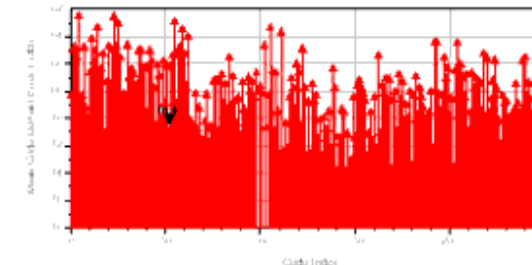

PCDE Waveforms

EVM Measurement

This measurement is used to test error vector magnitude (EVM) defined in 3GPP TS 25.101, section 6.8.2.

EVM is a measure of the difference between the theoretical waveform and a modified version of the measured waveform. This difference is called the error vector. The measured waveform is modified by first passing it through a matched Root Raised Cosine filter with a bandwidth of 3.84MHz and 0.22 roll-off. The waveform is then further modified by selecting the frequency, absolute phase, absolute amplitude, and chip clock timing so as to minimize the error vector. The EVM result is defined as the root of the mean error vector power though the mean reference signal power expressed as a percent. The EVM cannot exceed 17.5%.

The data display contains two pages. At the top of each page, an identical table contains some basic measurement parameters. The 3GPPFDD_UE_TX_EVM Table page (the following figure) shows the EVM of the RF and Meas signals. The 3GPPFDD_UE_TX_EVM Equations page shows the criteria used to determine if the results pass or not.

Advanced Design System 2008

real(RF_FSource)/(1 MHz)	real(RF_Power_dBm)	real(RF_R)
1950.000	24.000	50.000

real(Meas_FMeasurement)/(1MHz)	real(Meas_RefR)
1950.000	50.000

RF EVM(%)

Meas EVM(%)

4.298E-13

0.050

3GPP Specification TS 25.101 (2000-12) section 6.8.2

Specification requirements

The modulation accuracy EVM shall not exceed 17.5% for the parameters specified in Table 6.15 of TS 25.101 section 6.8.2

Test results

Passed

EVM Measurement Results

Test Bench Variables for Data Displays

The following tables identify the reference variables used to set up this test bench:

Test Bench Constants Used to Set up 3GPP FDD User Equipment Signal

Constant	Value
SamplesPerChip	8
ChipRate	3.84 MHz
ChipsPerSlot	2560
SlotsPerFrame	15

Test Bench Equations Derived from Test Bench Parameters and Exported to the Data Display

Data Display Parameter	Equation with Test Bench Parameters
RF_FSource	FSource
RF_Power_dBm	$10 \cdot \log_{10}(\text{SourcePower}) + 30$
RF_R	SourceR
TimeStep	$1 / (\text{ChipRate} \cdot \text{SamplesPerChip})$ This is the test bench simulation time step
SlotTime	$\text{ChipsPerSlot} \cdot \text{SamplesPerChip} \cdot \text{TimeStep}$ This is the time duration of each slot

FrameTime	SlotTime*SlotsPerFrame
Meas_FMeasurement	FMeasurement
Meas_R	MeasR

Baseline Performance

- Test Computer Configuration
 - Pentium IV 2.4 GHz, 512 MB RAM, Red Hat Linux 7.3
- Conditions
 - Measurements made with default test bench settings.
 - RF DUT is an RF system behavior component.
 - The number of time points in one slot can be calculated by SamplesPerChip times ChipsPerSlot.
 ChipRate = 3.84 MHz
 SamplesPerChip = 8
 ChipsPerSlot = 2560
 Resultant WTB_TimeStep = 32.6 nsec; SlotTime = 666.7 μ time points per slot = 20480
- Simulation times and memory requirements

3GPPFDD_UE_TX Measurement	Slots Measured	Simulation Time (sec)	ADS Processes (MB)
RF_Envelope	1	9	207
Power	1	7	205
ACLR	1	91	205
ACLR_ST	1	47	209
Occupied BW	1	9	212
CDP	1	101	211
PCDE	1	436	212
EVM	1	434	205

Expected ADS Performance

Expected ADS performance is the combined performance of the baseline test bench and the RF DUT Circuit Envelope simulation with the same signal and number of time points. For example, if the RF DUT performance with Circuit Envelope simulation alone takes 2 hours and consumes 200 MB of memory (excluding the memory consumed by the core ADS product), then add these numbers to the Baseline Performance numbers to determine the expected ADS performance. This is valid only if the full memory consumed is from RAM. If RAM is less, larger simulation times may result due to increased disk access time for swap memory usage.

References

3GPPFDD_UE_TX Test Bench specific references:

1. 3GPP Technical Specification TS 25.211, "Physical channels and mapping of transport channels onto physical channels (FDD)" Release 1999.
http://www.3gpp.org/ftp/Specs/2002-03/R1999/25_series/25211-3a0.zip
2. 3GPP Technical Specification TS 25.212, "Multiplexing and Channel Coding (FDD)" Release 1999.
http://www.3gpp.org/ftp/Specs/2002-03/R1999/25_series/25212-390.zip
3. 3GPP Technical Specification TS 25.213, "Spreading and modulation (FDD)" Release 1999.
http://www.3gpp.org/ftp/Specs/2002-03/R1999/25_series/25213-370.zip
4. 3GPP Technical Specification TS 25.101, "UE Radio transmission and reception (FDD)" Release 1999.
http://www.3gpp.org/ftp/Specs/2002-03/R1999/25_series/25101-3a0.zip
5. 3GPP Technical Specification TS 34.121, "Terminal Conformance Specification, Radio Transmission and Reception (FDD)" Release 1999.
http://www.3gpp.org/ftp/Specs/2002-03/R1999/34_series/34121-380.zip

Setting up a Wireless Test Bench Analysis in the Wireless Test Bench Simulation documentation explains how to use test bench windows and dialogs to perform analysis tasks.

Setting Circuit Envelope Analysis Parameters in the Wireless Test Bench Simulation documentation explains how to set up circuit envelope analysis parameters such as convergence criteria, solver selection, and initial guess.

Setting Automatic Behavioral Modeling Parameters in the Wireless Test Bench Simulation documentation to learn how to improve simulation speed.

3GPP FDD Base Station Receiver Test

3GPPFDD_BS_RX is the test bench for 3GPP FDD base station receiver testing. The test bench provides a way for users to connect to an RF circuit device under test and determine its performance using pre-defined test bench measurements. This test bench provides signal measurements for reference sensitivity level, dynamic range, adjacent channel selectivity, and blocking and intermodulation characteristics.

The signal and the measurements are designed according to 3GPP Technical Specifications TS 25.104 and TS 25.141. Versions supported are 2000-03, 2000-12, and 2002-03.

This 3GPP FDD signal model is compatible with Agilent E4438C ESG Vector Signal Generator, Option 400 (3GPP W-CDMA Firmware Option for the E4438C ESG Vector Signal Generator). Details regarding Agilent E4438C ESG are included at the website <http://www.agilent.com/find/esg>.

This test bench includes a TX DSP section, an RF modulator, RF output source resistance, an RF DUT connection, RF

receivers, and DSP measurement blocks as illustrated in the following figure. The generated test signal is sent to the DUT.

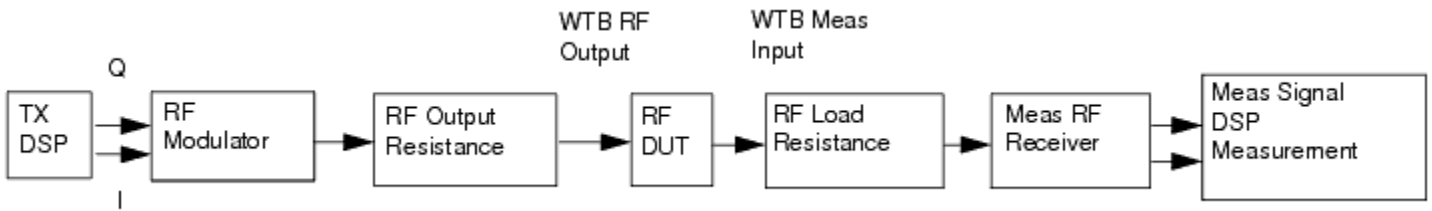

Receiver Wireless Test Bench Block Diagram

The 3GPPFDD_BS_RX test bench uses the uplink 12.2kbps reference measurement channel. One 12.2kbps DTCH (dedicated transport channel) and one 2.4 kbps DCCH (dedicated control channel) are multiplexed into one 60 kbps DPDCH (dedicated physical data channel). The 60kbps DPDCH and 15kbps DPCCH (dedicated physical control channel) are I/Q multiplexed into one data stream using different spread factors (64 for DPDCH, 256 for DPCCH), then scrambled with the specified scrambling code. The amplitude ratio of DPCCH/DPDCH is 0.7333 according to the TS25.104 Annex A. All measurements provide BER results for DCCH and DTCH.

Test Bench Basics

A template is provided for this test bench.

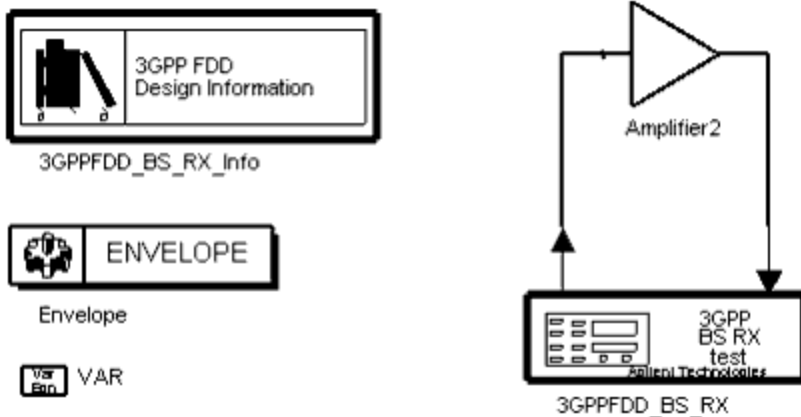

3GPPFDD Base Station Receiver Test Bench

To access the template:

1. In an Analog/RF schematic window select Insert > Template.
2. In the Insert > Template dialog box, choose 3GPPFDD_BS_RX_test, click OK; click left to place the template in the schematic window.

An example design using this template is available; from the ADS Main window click File > Example Project > WCDMA3G_RF_Verification_prj > 3GPPFDD_BS_RX_test .dsn.

The basics for using the test bench are:

- Connect to an RF DUT that is suitable for this test bench.
- CE_TimeStep, FSource, SourcePower, and FMeasurement parameter default values are typically accepted; if not, set values based on your requirements.
- Activate/deactivate measurement(s) based on your requirements.
- Run the simulation and view Data Display page(s) for your measurement(s).

For details, refer to [Test Bench Details](#).

Test Bench Details

The following sections provide details for setting up a test bench, setting measurement parameters for more control of the test bench, simulation measurement displays, and baseline performance.

Open and use the template:

1. In an Analog/RF schematic window select Insert > Template.
2. In the Insert > Template dialog box, choose 3GPPFDD_BS_RX_test , click OK ; click left to place the template in the schematic window.

Test bench setup is detailed here.

1. Replace the DUT (Amplifier2 is provided with this template) with an RF DUT that is suitable for this test bench. For general information regarding using certain types of DUTs, see Appendix A, RF DUT Limitations.
2. Set the Required Parameters .



Note

Refer to [3GPPFDD_BS_RX](#) for a complete list of parameters for this test bench.

Generally, default values can be accepted; otherwise, values can be changed by the user as needed.

- Set CE_TimeStep.
Cosimulation occurs between the test bench (using Agilent ADS Ptolemy Data Flow simulation technology) and the DUT (using Circuit Envelope simulation technology). Each technology requires its own simulation time step with time-step coordination occurring in the interface between the technologies.

CE_TimeStep defines the Circuit Envelope simulation time step to be used with this DUT. The CE_TimeStep must be set to a value equal to or a submultiple of (less than) WTB_TimeStep; otherwise, simulation will stop and an error message will be displayed.

The CE_TimeStep value is exported to the Choosing Analyses window in the Circuit Envelope Time Step field when the user clicks OK in the Wireless Test Bench Setup window.

Note that WTB_TimeStep is not user-settable. Its value is derived from other test bench parameter values; with default settings $WTB_TimeStep = 1 / (3.84e6 \times 8)$ sec. The value is displayed in the Data Display pages as TimeStep.

$$WTB_TimeStep = 1 / (\text{ChipRate} \times \text{SamplesPerChip})$$

where

ChipRate is the non-settable value (3.84 MHz)

SamplesPerChip is the number of waveform sampling points during pulse forming.

- Set FSource, SourcePower, and FMeasurement.
 - FSource defines the RF frequency for the signal input to the RF DUT.
 - SourcePower defines the power level for FSource. SourcePower is defined as the average power during the non-idle time of the signal.
 - FMeasurement defines the RF frequency output from the DUT to be measured.
 - MeasType specifies the type of measurement.
Pre-defined measurement settings (according to 3GPP specifications) are provided for signal power, AWGN interference, CW interference, and modulated interference.
3. Activate/deactivate (YES / NO) test bench measurements (refer to [3GPPFDD BS RX](#)). At least one measurement must be enabled.
 4. More control of the test bench can be achieved by setting Basic Parameters , Signal Parameters , and parameters for each activated measurement. For details refer to [Parameter Settings](#).
 5. The RF modulator (shown in the block diagram in [Receiver Wireless Test Bench Block Diagram](#)) uses FSource, SourcePower (Required Parameters) , MirrorSourceSpectrum (Basic Parameters) , GainImbalance, PhaseImbalance, I OriginOffset, Q OriginOffset, and IQ Rotation (Signal Parameters) .
The RF output resistance uses SourceR, SourceTemp, and EnableSourceNoise (Basic Parameters) . The RF output signal source has a 50-ohm (default) output resistance defined by SourceR.
RF output (and input to the RF DUT) is at the frequency specified (FSource), with the specified source resistance (SourceR) and with power (SourcePower) delivered into a matched load of resistance SourceR. The RF signal has additive Gaussian noise power set by resistor temperature (SourceTemp) (when EnableSourceNoise=YES).
Note that the Meas_in point of the test bench provides a resistive load to the RF DUT set by the MeasR value (50-ohm default) (Basic Parameters) .
The Meas signal contains linear and nonlinear signal distortions and time delays associated with the RF DUT input to output characteristics.
The TX DSP block (shown in the block diagram in [Receiver Wireless Test Bench Block Diagram](#)) uses other Signal Parameters.
 6. More control of Circuit Envelope analysis can be achieved by setting Envelope controller parameters. These settings include Enable Fast Cosim, which may speed the RF DUT simulation more than 10×. Setting these simulation options is described in Setting Fast Cosimulation Parameters and Setting Circuit Envelope Analysis Parameters in the Wireless Test Bench Simulation documentation.

7. To run a simulation, choose Simulation > Run in the Analog Design Environment main window. For details, refer to Running a Simulation in the Wireless Test Bench Simulation documentation.
8. Simulation results will appear in a Data Display window for each measurement. [Simulation Measurement Displays](#) describes results for each measurement available for this test bench. For details on Viewing Results refer to the Wireless Test Bench Simulation documentation.

3GPPFDD_BS_RX

This section provides parameter information for Required Parameters, Basic Parameters, Signal Parameters, and parameters for the various measurements.

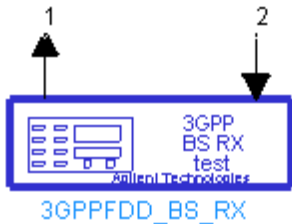

Description 3GPP FDD BS RX test
 Library WTB
 Class TSDF3GPPFDD_BS_RX
 Derived From baseWTB_RX

Parameters

Name	Description	Default	Sym	Unit	Type	Range
RequiredParameters						
CE_TimeStep	Circuit envelope simulation time step	1/3.84 MHz/8		sec	real	(0, ∞)
WTB_TimeStep	Set CE_TimeStep < = 1/3.84e6/SamplesPerChip. SamplesPerChip is in Signal Parameters tab.					
FSource	Source carrier	1950 MHz		Hz	real	(0, ∞)

Advanced Design System 2008

	frequency					
FMeasurement	Measurement carrier frequency	1950 MHz		Hz	real	(0, ∞)
MeasurementInfo	Available Measurements Each measurement has parameters on its tab/category below.					
MeasType	Measurement type: RefLevel, DynamicRange, ACS, Blocking, Intermod	RefLevel			enum	
BasicParameters						
SourceR	Source resistance	50 Ohm		Ohm	real	(0, ∞)
SourceTemp	Source resistor temperature	16.85		Celsius	real	[-273.15, ∞)
MeasR	Measurement resistance	50 Ohm		Ohm	real	[10, 1.0e6]
MirrorSourceSpec	Mirror source spectrum about carrier? NO, YES	NO			enum	
MirrorMeasSpec	Mirror meas spectrum about carrier? NO, YES	NO			enum	
DUT_DelayBound	DUT delay bound	10.0 usec		sec	real	[0, (400.0/3840000)]
TestBenchSeed	Random number generator seed	1234567			int	[0, ∞)
SignalParameters						

Advanced Design System 2008

GainImbalance	Gain imbalance, Q vs I	0.0		dB	real	$(-\infty, \infty)$
PhaseImbalance	Phase imbalance, Q vs I	0.0		deg	real	$(-\infty, \infty)$
I_OriginOffset	I origin offset (percent)	0.0			real	$(-\infty, \infty)$
Q_OriginOffset	Q origin offset (percent)	0.0			real	$(-\infty, \infty)$
IQ_Rotation	IQ rotation	0.0		deg	real	$(-\infty, \infty)$
SamplesPerChip	Samples per chip	8	S		int	[2, 32]
RRC_FilterLength	RRC filter chip length	16			int	[1, 1000]
SpecVersion	Secification version: Version 03_00, Version 12_00, Version 03_02	Version 12_00			enum	
RefLevelParameters						
RefLevel_WantedSignalPower	Wanted signal power: dbmtow(-121) RefLevel	dbmtow(-121) RefLevel		W	real enum	$(0, \infty)$
DynamicRangeParameters						
DynamicRange_WantedSignalPower	Wanted signal power: dbmtow(-91) DynamicRange	dbmtow(-91) DynamicRange		W	real enum	$(0, \infty)$
DynamicRange_AWGN_Density	AWGN interference power density: dbmtow(-73)/(3.84MHz) DynamicRange	dbmtow(-73)/(3.84MHz) DynamicRange		W	real enum	$(0, \infty)$
ACS_Parameters						
ACS_WantedSignalPower	Wanted signal power: dbmtow(-115)	dbmtow(-115) ACS		W	real enum	$(0, \infty)$

Advanced Design System 2008

	ACS					
ACS_ModFreqOffset	Modulated channel frequency offset: plus 5MHz ACS, minus 5MHz ACS	plus 5MHz ACS		Hz	real enum	$(-\infty, \infty)$
ACS_ModPower	Modulated channel power: dbmtow(-52) ACS	dbmtow(-52) ACS		W	real enum	$(0, \infty)$
BlockingParameters						
Blocking_Info	When Blocking_ModFreqOffset is +10 MHz / -10 MHz, the recommended SamplesPerChip (in Signal Parameters Tab) is 16. Also, set CE_TimeStep equal to or less than the value $1/3.84e6/\text{SamplesPerChip}$.					
Blocking_WantedSignalPower	Signal power: dbmtow(-115) Blocking	dbmtow(-115) Blocking		W	real enum	$(0, \infty)$
Blocking_ModFreqOffset	Modulated channel frequency offset: plus 10MHz Blocking, minus 10MHz Blocking	plus 10MHz Blocking		Hz	real enum	$(-\infty, \infty)$
Blocking_ModPower	Modulated channel power: dbmtow(-40) Blocking	dbmtow(-40) Blocking		W	real enum	$(0, \infty)$

Advanced Design System 2008

	Blocking					
IntermodParameters						
Intermod_Info	When Intermod_ModFreqOffset is +20 MHz / -20 MHz, the recommended SamplesPerChip (in Signal Parameters Tab) is 32. Also, set CE_TimeStep equal to or less than the value $1/3.84e6/\text{SamplesPerChip}$.					
Intermod_WantedSignalPower	Signal power: dbmtow(-115) Intermod	dbmtow(-115) Intermod		W	real enum	$[0, \infty)$
Intermod_CW_FreqOffset	Continuous wave frequency offset: plus 10MHz Intermod_CW, minus 10MHz Intermod_CW	plus 10MHz Intermod_CW		Hz	real enum	$(-\infty, \infty)$
Intermod_CW_Power	Continuous wave power: dbmtow(-48) Intermod_CW	dbmtow(-48) Intermod_CW		W	real enum	$(0, \infty)$
Intermod_ModFreqOffset	Modulated channel frequency offset: plus 20MHz Intermod_Mod, minus 20MHz Intermod_Mod	plus 20MHz Intermod_Mod		Hz	real enum	$(-\infty, \infty)$
Intermod_ModPower	Modulated channel power: dbmtow(-48)	dbmtow(-48) Intermod_Mod		W	real enum	$(0, \infty)$

	Intermod_Mod					
MeasurementParameters						
DisplayPages	RX measurement display pages: 3GPPFDD_BS_RX_test Table 3GPPFDD_BS_RX_test Equations					
FrameSetsMeasured	Sets of 4 frames measured	21			int	[2, ∞]
RAKE_PathDelay	Path delay for RAKE (samples)	0			int	[0, 2559]

Pin Inputs

Pin	Name	Description	Signal Type
2	Meas_In	Test bench measurement RF input from RF circuit	timed

Pin Outputs

Pin	Name	Description	Signal Type
1	RF_Out	Test bench RF output to RF circuit	timed

Parameter Settings

More control of the test bench can be achieved by setting parameters on the Basic Parameters, Signal Parameters, and measurements categories for the activated measurements. Parameters for each category are described in the following sections.

 **Note**
For required parameter information, see [Set the Required Parameters.](#)

Basic Parameters

1. SourceR is the RF output source resistance.
2. SourceTemp is the RF output source resistance temperature (oC) and sets noise density in the RF output signal to $(k(\text{SourceTemp}+273.15))$ Watts/Hz, where k is Boltzmann's constant.
3. MeasR defines the load resistance for the RF DUT output Meas signal into the test bench. This resistance loads the RF DUT output; it is also the reference resistance for Meas signal power measurements.
4. MirrorSourceSpectrum is used to invert the polarity of the Q envelope of the generated RF signal before it is sent to the RF DUT. Depending on the configuration and number of mixers in an RF transmitter, the signal at the input of the DUT may need to be mirrored. If such an RF signal is desired, set this parameter to YES.
5. MirrorMeasSpectrum is used to invert the polarity of the Q envelope in the Meas_in RF signal input to the test bench (and output from the RF DUT). Depending on the configuration and number of mixers in the RF DUT, the signal at its output may be mirrored compared to the signal generated by the signal source (before any mirroring is done because of the MirrorSourceSpectrum setting). Proper demodulation and measurement of the RF DUT output signal requires that its RF envelope is not mirrored compared to the signal generated by the signal source (before any mirroring is done because of the MirrorSourceSpectrum setting). If the Meas_in RF signal is mirrored, set this parameter to YES. Proper setting of this parameter is required for measurements on the Meas_in signal in RX text benches and results in measurement on a signal with no spectrum mirroring.
6. TestBenchSeed is an integer used to seed the random number generator used with the test bench. This value is used by all test bench random number generators, except those RF DUT components that use their own specific seed parameter. TestBenchSeed initializes the random number generation. The same seed value produces the same random results, thereby giving you predictable simulation results. To generate repeatable random output from simulation to simulation, use any positive seed value. If you want the output to be truly random, enter the seed value of 0.
7. DUT_DelayBound is the maximum time delay introduced by the DUT.

Signal Parameters

1. GainImbalance, PhaseImbalance, I_OriginOffset, Q_OriginOffset, and IQ_Rotation are used to add certain impairments to the ideal output RF signal. Impairments are added in the order described here. The unimpaired RF I and Q envelope voltages have gain and phase imbalance applied. The RF is given by:

$$V_{RF}(t) = A \left(V_I(t) \cos(\omega_c t) - g V_Q(t) \sin\left(\omega_c t + \frac{\Phi\pi}{180}\right) \right)$$

where A is a scaling factor that depends on the SourcePower and SourceR parameters specified by the user, $V_I(t)$ is the in-phase RF envelope, $V_Q(t)$ is the quadrature phase RF envelope, g is the gain imbalance

$$g = 10^{\frac{\text{GainImbalance}}{20}}$$

and, Φ (in degrees) is the phase imbalance.

Next, the signal $V_{RF}(t)$ is rotated by IQ_Rotation degrees. The I_OriginOffset and Q_OriginOffset are then

applied to the rotated signal. Note that the amounts specified are percentages with respect to the output rms voltage. The output rms voltage is given by $\sqrt{2 \times \text{SourceR} \times \text{SourcePower}}$.

2. `SamplesPerChip` is used to set the number of samples in a chip.
The default value is set to 8 to display settings according to the 3GPP standard. It can be set to a larger value for a simulation frequency bandwidth wider than 8×3.84 MHz. It can be set to a smaller value for faster simulation times; however, this will result in lower signal fidelity. If `SamplesPerChip` = 8, the simulation RF bandwidth is larger than the signal bandwidth by a factor of 8 (e.g., simulation RF bandwidth = 8×3.84 MHz).
3. `RRC_FilterLength` is used to set root raised-cosine (RRC) filter length in chips
The default value is set to 16 to transmit a 3GPP FDD uplink signal in time and frequency domains based on the 3GPP standard [4]. It can be set to a smaller value for faster simulation times; however, this will result in lower signal fidelity.
4. `SpecVersion` is used to specify the 3GPP specification versions 2000-03, 2000-12, or 2002-03.

RefLevel Parameters

`RefLevel_WantedSignalPower` is the RF_out power for the reference sensitivity level test. (MeasType = RefLevel)

DynamicRange Parameters

1. `DynamicRange_WantedSignalPower` is the RF_out power for the dynamic range test. (MeasType = DynamicRange)
2. `DynamicRange_AWGN_Density` is the interference additive white gaussian noise signal power density.

ACS Parameters

1. `ACS_WantedSignalPower` is the RF_out power for the adjacent channel selectivity test. (MeasType = ACS)
2. `ACS_ModFreqOffset` is the modulated adjacent channel signal frequency offset from the center frequency (FSource) of the assigned channel.
3. `ACS_ModPower` is modulated adjacent channel signal power.

Blocking Parameters

1. `Blocking_WantedSignalPower` is the RF_out power for the blocking test. (MeasType = Blocking)
2. `Blocking_ModFreqOffset` is the unwanted modulated signal frequency offset (other than adjacent channel) from the center frequency (FSource) of the assigned channel.
3. `Blocking_ModPower` is the unwanted modulated signal power.

Intermod Parameters

1. Intermod_WantedSignalPower is the RF_out power for the intermodulation test. (MeasType = Intermod)
2. Intermod_CW_FreqOffset is the continuous wave frequency offset (un-modulated signal) interference from the center frequency (FSource) of the assigned channel.
3. Intermod_CW_Power is the continuous wave interference power.
4. Intermod_ModFreqOffset is the unwanted modulated signal frequency offset from the center frequency (FSource) of the assigned channel.
5. Intermod_ModPower is the unwanted modulated signal power.

Measurement Parameters

1. DisplayPages provides Data Display page information for this measurement. It cannot be changed by the user.
2. FrameSetsMeasured is the number of frame sets to be measured. One frame set consists of four radio frames; one radio frame is 10 msec.
3. RAKE_PathDelay specifies the delay for the signal starting point. If RAKE_PathDelay=0, the delay is automatically searched; if set to a non-zero integer, the receiver uses this value for the signal starting point.

Simulation Measurement Displays

After running the simulation, results are displayed in the Data Display pages for each measurement. Each Data Display includes tables and equations pages. Simulation results include the BER of DTCH (dedicated transport channel), DCCH (dedicated control channel) and DPDCH (dedicated physical data channel), and required parameters to set up the test benches. Meas BER results are obtained by passing the signals through a DUT.

RF source power, RF source frequency, DUT output frequency, source output resistance, and DUT output resistance are also displayed.

All tests require DTCH and DCCH BER performance, which cannot exceed 0.001.

 **Note**
Measurement results from a wireless test bench have associated names that can be used in Data Display Expressions. For more information, refer to [Measurement Results for Expressions for 3GPP FDD Wireless Test Benches](#).

Reference Sensitivity Level

The reference sensitivity level (defined in section 7.2 of TS25.104 [4]) is measured when MeasType is set to RefLevel.

Test conditions are:

BS Reference Sensitivity Level (dBm)	BER
-121 dBm	BER shall not exceed 0.001

The following figure shows reference sensitivity level test results.

real(RF_FSource)/(1 MHz)	real(RF_Power_dBm)	real(RF_R)
1950.000	-121.000	50.000
real(Meas_FMeasurement)/(1 MHz)	real(Meas_R)	EbNO_RF_dB
1950.000	50.000	6.454

Meas BER Results

Meas_BER.DTCH_BER	Meas_BER.DCCH_BER	Meas_BER.DPDCH_BER
0.000	0.000	0.000

3GPP Specification TS 25.104 (2000-12) section 7.2

Specification requirements

The DTCH and DCCH BER shall not exceed 0.001 according to TS 25.104.

Test results

Passed

Reference Sensitivity Level Test Results

Dynamic Range

The dynamic range (defined in section 7.3 of TS25.104 [4]) is measured when MeasType is set to DynamicRange. Test conditions are:

Parameter	Level	Unit
Wanted signal	-91	dBm
Interfering AWGN signal	-73	dBm/3.84MHz

[Dynamic Range Test Results](#) shows the dynamic range test results.

real(RF_FSource)/(1 MHz)	real(RF_Power_dBm)	real(RF_R)
1950.000	-91.000	50.000
real(Meas_FMeasurement)/(1 MHz)	real(Meas_R)	EbN0_RF_dB
1950.000	50.000	36.454

Meas BER Results

Meas_BER.DTCH_BER	Meas_BER.DCCH_BER	Meas_BER.DPDCH_BER
0.000	0.000	0.002

3GPP Specification TS 25.104 (2000-12) section 7.3

Specification requirements

The DTCH and DCCH BER shall not exceed 0.001 according to TS 25.104.

Test results

Passed

Dynamic Range Test Results

Adjacent Channel Selectivity

Adjacent channel sensitivity (defined in section 7.4 of TS25.104 [4]) is measured when MeasType is set to ACS. Test conditions are:

Parameter	Level	Unit
Wanted signal	-115	dBm
Interfering signal	-52	dBm
Fuw (Modulated)	□5	MHz

The interfering signal is a modulated uplink signal with 1 DPCCH + 1 DPDCH, where the DPDCH rate is 960kbps. Fuw is the frequency offset of the modulated signal. The following figure shows the adjacent channel sensitivity results.

real(RF_FSource)/(1 MHz)	real(RF_Power_dBm)	real(RF_R)
1950.000	-115.000	50.000
real(Meas_FMeasurement)/(1 MHz)	real(Meas_R)	EbN0_RF_dB
1950.000	50.000	12.454

Meas BER Results

Meas_BER.DTCH_BER	Meas_BER.DCCH_BER	Meas_BER.DPDCH_BER
0.000	0.000	0.002

3GPP Specification TS 25.104 (2000-12) section 7.4

Specification requirements

The DTCH and DCCH BER shall not exceed 0.001 according to TS 25.104.

Test results

Passed

Adjacent Channel Sensitivity Test Results

Blocking Characteristics

Blocking characteristics (defined in section 7.5 in TS25.104[4]) are tested when MeasType is set to Blocking. Test conditions are:

Interfering Signal Level	Wanted Signal Level	Minimum Offset of Interfering Signal	Type of Interfering Signal
-40dBm	-115dBm	±10MHz	WCDMA signal with one code

The following figure shows the blocking characteristics test results.

real(RF_FSource)/(1 MHz)	real(RF_Power_dBm)	real(RF_R)
1950.000	-115.000	50.000
real(Meas_FMeasurement)/(1 MHz)	real(Meas_R)	EbN0_RF_dB
1950.000	50.000	12.454

Meas BER Results

Meas_BER.DTCH_BER	Meas_BER.DCCH_BER	Meas_BER.DPDCH_BER
0.000	0.000	0.003

3GPP Specification TS 25.104 (2000-12) section 7.5

Specification requirements

The DTCH and DCCH BER shall not exceed 0.001 according to TS 25.104.

Test results

Passed

Blocking Characteristics Test Results

Intermodulation Characteristics

Intermodulation characteristics (defined in section 7.6 in TS25.104[4]) are tested when MeasType is set to Intermod. Test conditions are:

Interfering Signal Level	Offset	Type of Interfering Signal
-48 dBm	±10 MHz	CW signal
-48 dBm	±20 MHz	WCDMA signal with one code

In the RF channel, there are two intermodulation response signals that have a specific frequency relationship to the requisite signal:

- By default, the continuous wave interference has a +10 MHz frequency offset from the central carrier frequency; its power is -48 dBm.
- By default, the modulated interfering signal has a +20 MHz offset from the center carrier frequency; its power is -48 dBm/3.84 MHz.

The following figure shows intermodulation characteristics test results.

real(RF_FSource)/(1 MHz)	real(RF_Power_dBm)	real(RF_R)
1950.000	-115.000	50.000
real(Meas_FMeasurement)/(1 MHz)	real(Meas_R)	EbNO_RF_dB
1950.000	50.000	12.454

Meas BER Results

Meas_BER.DTCH_BER	Meas_BER.DCCH_BER	Meas_BER.DPDCH_BER
0.000	0.000	0.000

3GPP Specification TS 25.104 (2000-12) section 7.6

Specification requirements

The DTCH and DCCH BER shall not exceed 0.001 according to TS 25.104.

Test results

Passed

Intermodulation Characteristics Test Results

Test Bench Variables for Data Displays

The following table identifies the reference variables used to set up this test bench.

Test Bench Equations Derived from Test Bench Parameters and Exported to the Data Display

Data Display Parameter	Equation with Test Bench Parameters
Spec_Version	SpecVersion
RF_FSource	FSource
RF_R	SourceR
RF_SourceTemp	SourceTemp
RF_Power_dBm	30 + 10 log(WantedSignalPower), where WantedSignalPower = RefLevel_WantedSignalPower, or DynamicRange_WantedSignalPower, or ACS_WantedSignalPower, or Blocking_WantedSignalPower, or Intermod_WantedSignalPower, according to MeasType setting.
ChipRate	3.84MChips/Second

Advanced Design System 2008

SlotTime	0.667ms
FrameTime	10ms
TimeStep	$1/(3.84e6 * \text{SamplesPerChip})$
Meas_FMeasurement	FMeasurement
Meas_R	MeasR
FrameNum	FramSetsMeasured * 4
AWGN_Density	$30 + 10 \log(\text{DynamicRange_AWGN_Density})$, when MeasType = DynamicRange
ModFreq	FSource + ModFreqOffset, where ModFreqOffset = ACS_ModFreqOffset, or Blocking_ModFreqOffset, or Intermod_ModFreqOffset, according to MeasType = ACS, Blocking, or Intermod.
ModePower_dBm	$30 + 10 \log(\text{ModPower})$, where ModPower = ACS_ModPower, or Blocking_ModPower or Intermod_ModPower, according to MeasType = ACS, Blocking, or Intermod.
CWFreq	FSource + Intermod_CW_FreqOffset, when MeasType = Intermod
CWPower_dBm	$30 + 10 \log(\text{Intermod_CW_Power})$, when MeasType = Intermod

Baseline Performance

- Test Computer Configuration
 - Pentium IV 2.4 GHz, 512 MB RAM, Red Hat Linux 7.3
- Conditions
 - Measurements made with default test bench settings.
 - RF DUT is an RF system behavior component.
 - The number of time points in one slot can be calculated by SamplesPerChip times ChipsPerSlot.
 ChipRate = 3.84 MHz
 SamplesPerChip = 8
 ChipsPerSlot = 2560
 1 FrameSet = 4 Frames
 Resultant WTB_TimeStep = 32.6 nsec; SlotTime = 666.7 μ time points per slot = 20480
- Simulation times and memory requirements.

Measurement	FrameSets Measured	Simulation Time (sec)	ADS Processes (MB)
RefLevel	21	1858	105
DynamicRange	21	1941	106

Advanced Design System 2008

ACS	21	2642	107
Blocking	21	2533	106
Intermod	21	2440	107

Expected ADS Performance

Expected ADS performance is the combined performance of the baseline test bench and the RF DUT Circuit Envelope simulation with the same signal and number of time points. For example, if the RF DUT performance with Circuit Envelope simulation alone takes 2 hours and consumes 200 MB of memory (excluding the memory consumed by the core ADS product), then add these numbers to the Baseline Performance numbers to determine the expected ADS performance. This is valid only if the full memory consumed is from RAM. If RAM is less, larger simulation times may result due to increased disk access time for swap memory usage.

References

1. 3GPP Technical Specification TS 25.211, "Physical channels and mapping of transport channels onto physical channels (FDD)" Release 1999.
http://www.3gpp.org/ftp/Specs/2002-03/R1999/25_series/25211-3a0.zip
2. 3GPP Technical Specification TS 25.212, "Multiplexing and Channel Coding (FDD)" Release 1999.
http://www.3gpp.org/ftp/Specs/2002-03/R1999/25_series/25212-390.zip
3. 3GPP Technical Specification TS 25.213, "Spreading and modulation (FDD)" Release 1999.
http://www.3gpp.org/ftp/Specs/2002-03/R1999/25_series/25213-370.zip
4. 3GPP Technical Specification TS 25.104, "UTRA (BS) FDD; Radio transmission and Reception" Release 1999.
http://www.3gpp.org/ftp/Specs/2002-03/R1999/25_series/25104-3a0.zip
5. 3GPP Technical Specification TS 25.141, "Base station conformance testing (FDD)" Release 1999.
http://www.3gpp.org/ftp/Specs/2002-03/R1999/25_series/25141-390.zip

Setting up a Wireless Test Bench Analysis in the Wireless Test Bench Simulation documentation explains how to use test bench windows and dialogs to perform analysis tasks.

Setting Circuit Envelope Analysis Parameters in the Wireless Test Bench Simulation documentation explains how to set up circuit envelope analysis parameters such as convergence criteria, solver selection, and initial guess.

Setting Automatic Behavioral Modeling Parameters in the Wireless Test Bench Simulation documentation to learn how to improve simulation speed.

3GPP FDD User Equipment Receiver Test

3GPPFDD_UE_RX is the test bench for 3GPP FDD user equipment receiver testing. The test bench provides a way for users to connect to an RF circuit device under test and determine its performance using pre-defined test bench measurements. This test bench provides signal measurements for reference sensitivity level, maximum input level, adjacent channel selectivity, and blocking and intermodulation characteristics.

The signal and the measurements are designed according to 3GPP Technical Specifications TS 25.101 and TS 34.121. Versions supported are 2000-03, 2000-12, and 2002-03.

This 3GPP FDD signal model is compatible with Agilent E4438C ESG Vector Signal Generator, Option 400 (3GPP W-CDMA Firmware Option for the E4438C ESG Vector Signal Generator). Details regarding Agilent E4438C ESG are included at the website <http://www.agilent.com/find/esg>.

This test bench includes a TX DSP section, an RF modulator, RF output source resistance, an RF DUT connection, RF receivers, and DSP measurement blocks as illustrated in the following figure. The generated test signal is sent to the DUT.

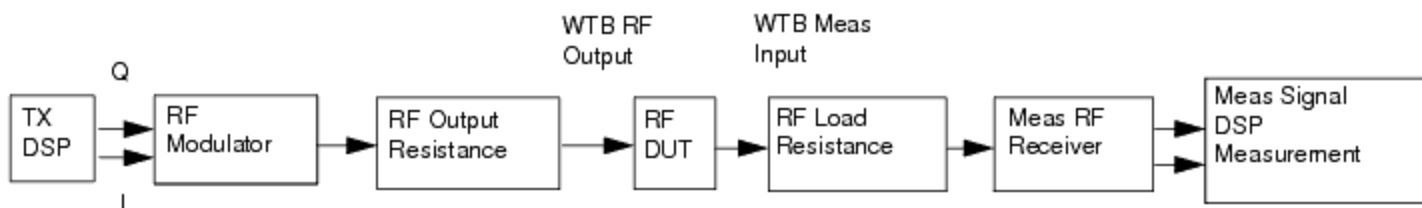

Receiver Wireless Test Bench Block Diagram

The 3GPPFDD_UE_RX test bench uses the downlink 12.2kbps reference measurement channel. One 12.2kbps DTCH (dedicated transport channel) and one 2.4kbps DCCH (dedicated control channel) are multiplexed into one 60kbps DPCH (dedicated physical data channel). The signal source includes one DPCH, one PCCPCH (primary common control physical channel), one PSCH (primary synchronization channel), one SSCH (secondary synchronization channel), one CPICH (common pilot channel), and one PICH (page indication channel).

In user equipment receiver measurements except maximum input level, channels are set according to the following table.

Downlink Physical Channels Transmitted During a Connection

Physical Channel	Power
P-CPICH	$P\text{-CPICH_Ec} / DPCH_Ec = 7\text{dB}$
P-CCPCH	$P\text{-CCPCH_Ec} / DPCH_Ec = 5\text{dB}$
SCH	$SCH_Ec / DPCH_Ec = 5\text{dB}$
PICH	$PICH_Ec / DPCH_Ec = 2\text{dB}$

DPCH	Test dependent power
------	----------------------

SCH power is divided equally between primary and secondary synchronous channels, so the $P\text{-SCH}_{Ec}/(DPCH_{Ec} + S\text{-SCH}_{Ec}) = 2\text{dB}$.

For the maximum input level measurement, the OCNS interference is set to the power necessary to achieve the required $DPCH_{Ec}/I$ or of -19dB . The gain of the other channels remain the same.

All measurements provide BER results for DCCH and DTCH.

Test Bench Basics

A template is provided for this test bench.

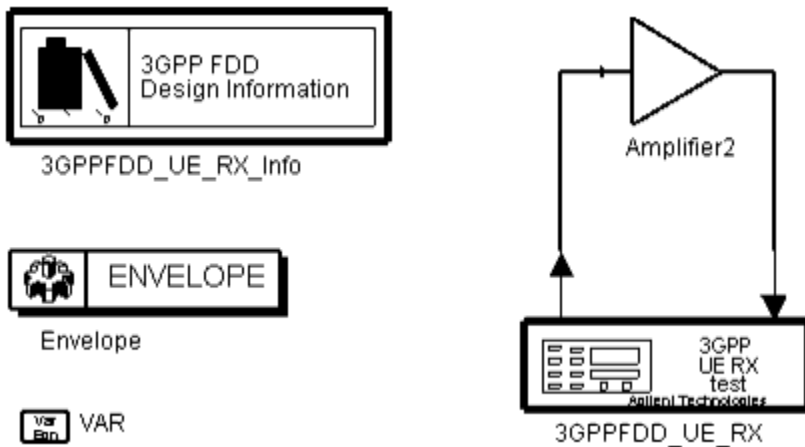

3GPPFDD User Equipment Receiver Test Bench

To access the template:

1. In an Analog/RF schematic window select Insert > Template.
2. In the Insert > Template dialog box, choose 3GPPFDD_UE_RX_test, click OK; click left to place the template in the schematic window.

An example design using this template is available; from the ADS Main window click File > Example Project > WCDMA3G_RF_Verification_prj > 3GPPFDD_UE_RX_test .dsn.

The basics for using the test bench are:

- Connect to an RF DUT that is suitable for this test bench.
- CE_TimeStep, FSource, SourcePower, and FMeasurement parameter default values are typically accepted; if not, set values based on your requirements.
- Activate/deactivate measurement(s) based on your requirements.
- Run the simulation and view Data Display page(s) for your measurement(s).

For details, refer to [Test Bench Details](#).

Test Bench Details

The following sections provide details for setting up a test bench, setting measurement parameters for more control of the test bench, simulation measurement displays, and baseline performance.

Open and use the template:

1. In an Analog/RF schematic window select Insert > Template.
2. In the Insert > Template dialog box, choose 3GPPFDD_UE_RX_test, click OK; click left to place the template in the schematic window.

The test bench setup is detailed here.

1. Replace the DUT (Amplifier2 is provided with this template) with an RF DUT that is suitable for this test bench. For general information regarding using certain types of DUTs, see Appendix A, RF DUT Limitations.
2. Set the Required Parameters.



Note

Refer to [3GPPFDD_UE_RX](#) for a complete list of parameters for this test bench.

Generally, default values can be accepted; otherwise, values can be changed by the user as needed.

- Set CE_TimeStep.
Cosimulation occurs between the test bench (using Agilent Ptolemy Data Flow simulation technology) and the DUT (using Agilent Circuit Envelope simulation technology). Each technology requires its own simulation time step with time-step coordination occurring in the interface between the technologies.
CE_TimeStep defines the Circuit Envelope simulation time step to be used with this DUT. The CE_TimeStep must be set to a value equal to or a submultiple of (less than) WTB_TimeStep; otherwise, simulation will stop and an error message will be displayed.
The CE_TimeStep value is exported to the Choosing Analyses window in the Circuit Envelope Time Step field when the user clicks OK in the Wireless Test Bench Setup window.
Note that WTB_TimeStep is not user-settable. Its value is derived from other test bench parameter values; with default settings $WTB_TimeStep = 1/(3.84e6 \times 8)$ sec. The value is displayed in the Data Display pages as TimeStep.

$$WTB_TimeStep = 1/(\text{ChipRate} \times \text{SamplesPerChip})$$

where

ChipRate is the non-settable value (3.84 MHz)

SamplesPerChip is the number of waveform sampling points during pulse forming.

- Set FSource, SourcePower, and FMeasurement.
 - FSource defines the RF frequency for the signal input to the RF DUT.
 - SourcePower defines the power level for FSource. SourcePower is defined as the average power during the non-idle time of the signal.
 - FMeasurement defines the RF frequency output from the DUT to be measured.
 - MeasType specifies the type of measurement.
Pre-defined measurement settings (according to 3GPP specifications) are provided for Ior_Power, DPCH_Ec_2_Ior, CW interference, and modulated interference.
3. Activate/deactivate (YES / NO) test bench measurements (refer to [3GPPFDD UE RX](#)). At least one measurement must be enabled.
 4. More control of the test bench can be achieved by setting Basic Parameters, Signal Parameters, and parameters for each measurement. For details refer to [Parameter Settings](#).
 5. The RF modulator (shown in the block diagram in [Receiver Wireless Test Bench Block Diagram](#)) uses FSource, SourcePower (Required Parameters), MirrorSourceSpectrum (Basic Parameters), GainImbalance, PhaseImbalance, I OriginOffset, Q OriginOffset, and IQ Rotation (Signal Parameters).
The RF output resistance uses SourceR, SourceTemp, and EnableSourceNoise (Basic Parameters). The RF output signal source has a 50-ohm (default) output resistance defined by SourceR.
RF output (and input to the RF DUT) is at the frequency specified (FSource), with the specified source resistance (SourceR) and with power (SourcePower) delivered into a matched load of resistance SourceR. The RF signal has additive Gaussian noise power set by resistor temperature (SourceTemp) (when EnableSourceNoise=YES).
Note that the Meas_in point of the test bench provides a resistive load to the RF DUT set by the MeasR value (50 Ω default) (Basic Parameters).
The Meas signal contains linear and nonlinear signal distortions and time delays associated with the RF DUT input to output characteristics.
The TX DSP block (shown in the block diagram in [Receiver Wireless Test Bench Block Diagram](#)) uses other Signal Parameters.
 6. More control of the Circuit Envelope simulation of the RF DUT is achieved by selecting Options in the Choosing Analysis window. These advanced options include enabling Automatic Behavioral Modeling (which may speed up the RF DUT simulation by over 10X), and setting Circuit Envelope parameters. Setting these simulations options is described in Setting Automatic Behavioral Modeling Parameters and Setting Circuit Envelope Analysis Parameters in the Wireless Test Bench Simulation documentation.
 7. To run a simulation, choose Simulation > Run in the Analog Design Environment main window.
For details, refer to R unning a Simulation in the Wireless Test Bench Simulation documentation.
 8. Simulation results will appear in a Data Display window for each measurement. [Simulation Measurement Displays](#) describes results for each measurement available for this test bench.
For details on Viewing Results refer to the Wireless Test Bench Simulation documentation.

This section provides parameter information for Required Parameters, Basic Parameters, Signal Parameters, and parameters for the various measurements.



Description 3GPP FDD UE RX BER
 Library WTB
 Class TSDF3GPPFDD_UE_RX
 Derived From baseWTB_RX

Parameters

Name	Description	Default	Sym	Unit	Type	Range
RequiredParameters						
CE_TimeStep	Circuit envelope simulation time step	1/3.84 MHz/8		sec	real	(0, ∞)
WTB_TimeStep	Set CE_TimeStep < = 1/3.84e6/SamplesPerChip. SamplesPerChip is in Signal Parameters tab.					
FSource	Source carrier frequency	2140 MHz		Hz	real	(0, ∞)
FMeasurement	Measurement carrier frequency	2140 MHz		Hz	real	(0, ∞)
MeasurementInfo	Available Measurements Each measurement has parameters on					

Advanced Design System 2008

	its tab/category below.					
MeasType	Measurement type: RefLevel, MaxLevel, ACS, Blocking, Intermod	RefLevel			enum	
BasicParameters						
SourceR	Source resistance	50 Ohm		Ohm	real	(0, ∞)
SourceTemp	Source resistor temperature	16.85		Celsius	real	[-273.15, ∞)
MeasR	Measurement resistance	50 Ohm		Ohm	real	[10, 1.0e6]
MirrorSourceSpec	Mirror source spectrum about carrier? NO, YES	NO			enum	
MirrorMeasSpec	Mirror meas spectrum about carrier? NO, YES	NO			enum	
DUT_DelayBound	DUT delay bound	10.0 usec		sec	real	[0, (400.0/3840000)]
TestBenchSeed	Random number generator seed	1234567			int	[0, ∞)
SignalParameters						
GainImbalance	Gain imbalance, Q vs I	0.0		dB	real	(-∞, ∞)
PhaseImbalance	Phase imbalance, Q vs I	0.0		deg	real	(-∞, ∞)
I_OriginOffset	I origin offset (percent)	0.0			real	(-∞, ∞)
Q_OriginOffset	Q origin offset	0.0			real	(-∞, ∞)

Advanced Design System 2008

	(percent)					
IQ_Rotation	IQ rotation	0.0		deg	real	$(-\infty, \infty)$
SamplesPerChip	Samples per chip	8	S		int	[2, 32]
RRC_FilterLength	RRC filter length (chips)	16			int	[1, 1000]
SpecVersion	Secification version: Version 03_00, Version 12_00, Version 03_02	Version 12_00			enum	
RefLevelParameters						
RefLevel_Ior_Power	Ior power: Based on FSource RefLevel, (Band I) dbmtow(-106.7) RefLevel, (Band II) dbmtow(-104.7) RefLevel, (Band III) dbmtow(-103.7) RefLevel	Based on FSource RefLevel		W	real enum	$[0, \infty)$
RefLevel_DPCH_Ior	DPCH Ior to Ior value: -10.3dB RefLevel	-10.3dB RefLevel		dB	real enum	$(-\infty, -10.3]$
MaxLevelParameters						
MaxLevel_Ior_Power	Ior power: dbmtow(-25) MaxLevel	dbmtow(-25) MaxLevel		W	real enum	$(0, \infty)$
MaxLevel_DPCH_Ior	DPCH Ior to Ior value: -19dB MaxLevel	-19dB MaxLevel		dB	real enum	$(-\infty, -10.3]$
ACS_Parameters						
ACS_Ior_Power	Ior power: dbmtow(-92.7) ACS	dbmtow(-92.7) ACS		W	real enum	$(0, \infty)$

Advanced Design System 2008

ACS_DPCH_Ec_2DPCH_Ec to Ior value:	-10.3dB ACS		dB	real enum	$(-\infty, -10.3]$
ACS_ModFreqOffset	Modulated channel frequency offset: plus 5MHz ACS, minus 5MHz ACS	plus 5MHz ACS	Hz	real enum	$(-\infty, \infty)$
ACS_ModPower	Modulated channel power: dbmtow(-52) ACS	dbmtow(-52) ACS	W	real enum	$(0, \infty)$
BlockingParameters					
Blocking_Info	When Blocking_ModFreqOffset is +10 MHz / -10 MHz, the recommended SamplesPerChip (in Signal Parameters Tab) is 16. Also, set CE_TimeStep equal to or less than the value $1/3.84e6/\text{SamplesPerChip}$.				
Blocking_Ior_Power	Power power: Based on FSource Blocking, (Band I) dbmtow(-103.7) Blocking, (Band II) dbmtow(-101.7) Blocking, (Band III) dbmtow(-100.7) Blocking	Based on FSource Blocking	W	real enum	$[0, \infty)$
Blocking_DPCH_Ec_2DPCH_Ec to Ior value:	-10.3dB Blocking		dB	real enum	$(-\infty, -10.3]$

Advanced Design System 2008

	-10.3dB Blocking					
Blocking_ModFreqOffset	Offset of modulated channel frequency offset: plus 10MHz Blocking, minus 10MHz Blocking, plus 15MHz Blocking, minus 15MHz Blocking	plus 10MHz Blocking		Hz	real enum	$(-\infty, \infty)$
Blocking_ModPower	Modulated channel power: dbmtow(-56) 10MHz Blocking, dbmtow(-44) 15MHz Blocking	dbmtow(-56) 10MHz Blocking		W	real enum	$(0, \infty)$
IntermodParameters						
Intermod_Info	When Intermod_ModFreqOffset is +20 MHz / -20 MHz, the recommended SamplesPerChip (in Signal Parameters Tab) is 32. Also, set CE_TimeStep equal to or less than the value $1/3.84e6/\text{SamplesPerChip}$.					
Intermod_IorPower	Intermod power: Based on FSource Intermod, (Band I) -103.7 dBm Intermod,	Based on FSource Intermod		W	real enum	$[0, \infty)$

Advanced Design System 2008

	(Band II) -101.7 dBm Intermod, (Band III) -100.7 dBm Intermod					
Intermod_DPCH	DPCH for Inter value: -10.3dB Intermod	-10.3dB Intermod		dB	real enum	$(-\infty, -10.3]$
Intermod_CW_FreqOffset	Carrier wave frequency offset: plus 10MHz Intermod_CW, minus 10MHz Intermod_CW	plus 10MHz Intermod_CW		Hz	real enum	$(-\infty, \infty)$
Intermod_CW_Power	Continuous wave power: dbmtow(-46) Intermod_CW	dbmtow(-46) Intermod_CW		W	real enum	$(0, \infty)$
Intermod_ModFreqOffset	Modulated channel frequency offset: plus 20MHz Intermod_Mod, minus 20MHz Intermod_Mod	plus 20MHz Intermod_Mod		Hz	real enum	$(-\infty, \infty)$
Intermod_ModPower	Modulated channel power: dbmtow(-46) Intermod_Mod	dbmtow(-46) Intermod_Mod		W	real enum	$(0, \infty)$
MeasurementParameters						
DisplayPages	RX measurement display pages: 3GPPFDD_UE_RX Tables 3GPPFDD_UE_RX Equations					
FrameSetsMeasure	Set of 4 frames	21			int	$[2, \infty)$

	measured					
RAKE_PathDelay	Path delay for RAKE (samples)	0			int	[0, 2559]

Pin Inputs

Pin	Name	Description	Signal Type
2	Meas_In	Test bench measurement RF input from RF circuit	timed

Pin Outputs

Pin	Name	Description	Signal Type
1	RF_Out	Test bench RF output to RF circuit	timed

Parameter Settings

More control of the test bench can be achieved by setting parameters on the Basic Parameters, Signal Parameters, and measurements categories for the activated measurements. Parameters for each category are described in the following sections.



Note

For required parameter information, see [Set the Required Parameters.](#)

Basic Parameters

1. SourceR is the RF output source resistance.
2. SourceTemp is the RF output source resistance temperature (oC) and sets noise density in the RF output signal to $(k(\text{SourceTemp}+273.15))$ Watts/Hz, where k is Boltzmann's constant.
3. MeasR defines the load resistance for the RF DUT output Meas signal into the test bench. This resistance loads the RF DUT output; it is also the reference resistance for Meas signal power measurements.
4. MirrorSourceSpectrum is used to invert the polarity of the Q envelope of the generated RF signal before it is sent to the RF DUT. Depending on the configuration and number of mixers in an RF transmitter, the signal at the input of the DUT may need to be mirrored. If such an RF signal is desired, set this parameter to YES.
5. MirrorMeasSpectrum is used to invert the polarity of the Q envelope in the Meas_in RF signal input to the test bench (and output from the RF DUT). Depending on the configuration and number of mixers in the RF DUT, the signal at its output may be mirrored compared to the signal generated by the signal source (before any mirroring is done because of the MirrorSourceSpectrum setting). Proper demodulation and measurement of the RF DUT

output signal requires that its RF envelope is not mirrored compared to the signal generated by the signal source (before any mirroring is done because of the MirrorSourceSpectrum setting). If the Meas_in RF signal is mirrored, set this parameter to YES. Proper setting of this parameter is required for measurements on the Meas_in signal in RX text benches and results in measurement on a signal with no spectrum mirroring.

6. TestBenchSeed is an integer used to seed the random number generator used with the test bench. This value is used by all test bench random number generators, except those RF DUT components that use their own specific seed parameter. TestBenchSeed initializes the random number generation. The same seed value produces the same random results, thereby giving you predictable simulation results. To generate repeatable random output from simulation to simulation, use any positive seed value. If you want the output to be truly random, enter the seed value of 0.
7. DUT_DelayBound is the maximum time delay introduced by the DUT.

Signal Parameters

1. GainImbalance, PhaseImbalance, I_OriginOffset, Q_OriginOffset, and IQ_Rotation are used to add certain impairments to the ideal output RF signal. Impairments are added in the order described here. The unimpaired RF I and Q envelope voltages have gain and phase imbalance applied. The RF is given by:

$$V_{RF}(t) = A \left(V_I(t) \cos(\omega_c t) - g V_Q(t) \sin\left(\omega_c t + \frac{\Phi\pi}{180}\right) \right)$$

where A is a scaling factor that depends on the SourcePower and SourceR parameters specified by the user, $V_I(t)$ is the in-phase RF envelope, $V_Q(t)$ is the quadrature phase RF envelope, g is the gain imbalance

$$g = 10^{\frac{\text{GainImbalance}}{20}}$$

and, Φ (in degrees) is the phase imbalance.

Next, the signal $V_{RF}(t)$ is rotated by IQ_Rotation degrees. The I_OriginOffset and Q_OriginOffset are then applied to the rotated signal. Note that the amounts specified are percentages with respect to the output rms voltage. The output rms voltage is given by $\sqrt{2 \times \text{SourceR} \times \text{SourcePower}}$.

2. SamplesPerChip is used to set the number of samples in a chip. The default value is set to 8 to display settings according to the 3GPP standard. It can be set to a larger value for a simulation frequency bandwidth wider than 8×3.84 MHz. It can be set to a smaller value for faster simulation; however, this will result in lower signal fidelity. If SamplesPerChip = 8, the simulation RF bandwidth is larger than the signal bandwidth by a factor of 8 (e.g., simulation RF bandwidth = 8×3.84 MHz).
3. RRC_FilterLength is used to set root raised-cosine (RRC) filter length in number of chips. The default value is set to 16 to transmit a 3GPP FDD downlink signal in time and frequency domains based on the 3GPP standard [4]. It can be set to a smaller value for faster simulation times; however, this will result in lower signal fidelity.
4. SpecVersion is used to specify the 3GPP specification versions 2000-03, 2000-12 and 2002-03.

RefLevel Parameters

1. RefLevel_Ior_Power is the RF_out power for the reference sensitivity level test (MeasType = RefLevel). If Based on FSource RefLevel is selected, RefLevel_Ior_Power will be set according to the Operating Band specified by FSource (see the following table). If FSource does not belong to any Operating Band, the nearest Operating Band will be used to determine RefLevel_Ior_Power.

UTRA FDD Frequency Bands and Ior for Reference Sensitivity Test

Operating Band	DL Frequencies, UE Receiver (FSource)	RefLevel_Ior_Power
I	2110 - 2170 MHz	-106.7 dBm
II	1930 - 1990 MHz	-104.7 dBm
III	1805 - 1880 MHz	-103.7 dBm

2. RefLevel_DPCH_Ec_2_Ior is the ratio of DPCH chip energy over I or power for the reference sensitivity level test.

MaxLevel Parameters

1. MaxLevel_Ior_Power is the RF_out power for the maximum input level test. (MeasType = MaxLevel)
2. MaxLevel_DPCH_Ec_2_Ior is the ratio of DPCH chip energy over I or power for the maximum input level test.

ACS Parameters

1. ACS_Ior_Power is the RF_out power for the adjacent channel selectivity test. (MeasType = ACS)
2. ACS_DPCH_Ec_2_Ior is the ratio of DPCH chip energy over I or power for the adjacent channel selectivity test.
3. ACS_ModFreqOffset is the modulated adjacent channel signal frequency offset from the center frequency (FSource) of the assigned channel.
4. ACS_ModPower is the modulated adjacent channel signal power.

Blocking Parameters

1. Blocking_Ior_Power is the RF_out power for the blocking test (MeasType = Blocking). If Based on FSource Blocking is selected, Blocking_Ior_Power will be set according to the Operating Band specified by FSource (see the following table). If FSource does not belong to any Operating Band, the nearest Operating Band will be used to determine Blocking_Ior_Power.

UTRA FDD Frequency Bands and Ior for Blocking Test

Operating Band	DL Frequencies, UE Receiver (FSource)	Blocking_Ior_Power
I	2110 - 2170 MHz	-103.7 dBm
II	1930 - 1990 MHz	-101.7 dBm
III	1805 - 1880 MHz	-100.7 dBm

2. Blocking_DPCH_Ec_2_Ior is the ratio of DPCH chip energy over I or power for the blocking test.
3. Blocking_ModFreqOffset is the unwanted modulated signal frequency offset (other than adjacent channel) from the center frequency (FSource) of the assigned channel.
4. Blocking_ModPower is the unwanted modulated signal power.

Intermod Parameters

1. Intermod_Ior_Power is the RF_out power for the intermodulation test (MeasType = Intermod). If Based on FSource Intermod is selected, Intermod_Ior_Power will be set according to the Operating Band specified by FSource (see the following table). If FSource does not belong to any Operating Band, the nearest Operating Band will be used to determine Intermod_Ior_Power.

UTRA FDD Frequency Bands and Ior for Intermodulation Test

Operating Band	DL Frequencies, UE Receiver (FSource)	Intermod_Ior_Power
I	2110 - 2170 MHz	-103.7 dBm
II	1930 - 1990 MHz	-101.7 dBm
III	1805 - 1880 MHz	-100.7 dBm

2. Intermod_DPCH_Ec_2_Ior is the ratio of DPCH chip energy over I or power for the intermodulation test.
3. Intermod_CW_FreqOffset is the frequency offset of the continuous wave (un-modulated signal) interference from the center frequency (FSource) of the assigned channel.
4. Intermod_CW_Power is the continuous wave interference power.
5. Intermod_ModFreqOffset is the unwanted modulated signal frequency offset from the center frequency (FSource) of the assigned channel.
6. Intermod_ModPower is the unwanted modulated signal power.

Measurement Parameters

1. DisplayPages provides Data Display page information for this measurement. It cannot be changed by the user.
2. FrameSetsMeasured is the number of frame sets to be measured. One frame set consists of four radio frames; one radio frame is 10 msec.
3. RAKE_PathDelay specifies the delay for the signal starting point. If RAKE_PathDelay=0, the delay is automatically searched; if set to a non-zero integer, the receiver uses this value for the signal starting point.

Simulation Measurement Displays

After running the simulation, results are displayed in the Data Display pages for each measurement. Each Data Display includes tables and equations pages. Simulation results include the BER of DTCH (dedicated transport channel), DCCH (dedicated control channel) and DPDCH (dedicated physical data channel), and required parameters to set up the test benches. Meas BER results are obtained by passing the signals through a DUT.

The DPCH chip energy, denoted by DPCH_Ec, is also displayed, as well as RF source frequency, DUT output frequency, source output resistance, and DUT output resistance.

All tests require DTCH and DCCH BER performance, which cannot exceed 0.001.

 **Note**
Measurement results from a wireless test bench have associated names that can be used in Data Display Expressions. For more information, refer to [Measurement Results for Expressions for 3GPP FDD Wireless Test Benches](#).

Reference Sensitivity Level

The reference sensitivity level (defined in section 7.2 of TS25.104 [4]) is measured when MeasType is set to RefLevel. Test conditions are:

Parameter	Unit	Level
DPCH_Ec	dBm/3.84MHz	-117
Ior	dBm/3.84MHz	-106.7

The DPCH_Ec_2_Ior is -10.3dB under these conditions. The following figure shows reference sensitivity level test results.

Advanced Design System 2008

real(RF_FSource)/(1 MHz)	real(RF_R)	real(Ior_Power_dBm)
2140.000	50.000	-106.700

real(Meas_FMeasurement)/(1 MHz)	real(Meas_R)	DPCH_Ec_dBm
2140.000	50.000	-117.000

EbNO_RF_dB
16.693

Meas BER Results

DTCH_AverageBER	DCCH_AverageBER	DPCH_AverageBER
0.000	0.000	2.083E-4

3GPP Specification TS 25.101 (2000-12) Section 7.3

Specification requirements

The DTCH and DCCH BER shall not exceed 0.001 according to TS 25.101

Test results

Passed

Reference Sensitivity Level Test Results

Maximum Input Level

The maximum input level (defined in section 7.4 of TS25.101 [4]) is measured when MeasType is set to MaxLevel. Test conditions are:

Parameter	Unit	Level
DPCH_Ec/Ior	dB	-19
Ior	dBm/3.84MHz	-25

The following figure shows the maximum input level test results.

Advanced Design System 2008

real(RF_FSource)/(1 MHz)	real(RF_R)	real(Ior_Power_dBm)
2140.000	50.000	-25.000

real(Meas_FMeasurement)/(1 MHz)	real(Meas_R)	DPCH_Ec_dBm
2140.000	50.000	-44.000

EbNO_RF_dB
89.693

Meas BER Results

DTCH_AverageBER	DCCH_AverageBER	DPCH_AverageBER
0.000	0.000	0.000

3GPP Specification TS 25.101 (2000-12) Section 7.4

Specification requirements

The DTCH and DCCH BER shall not exceed 0.001 according to TS 25.101

Test results

Passed

Maximum Input Level Test Results

Adjacent Channel Selectivity

The adjacent channel sensitivity (defined in section 7.5 of TS25.101 [4]) is measured when MeasType is set to ACS. Test conditions are:

Parameter	Unit	Level
DPCH_Ec	dBm/3.84MHz	-103
Ior	dBm/3.84MHz	-92.7
Ioac (modulated)	dBm/3.84MHz	-52
Fuw (offset)	MHz	±5

The I oac (modulated) signal consists of 16 dedicated data channels. F uw is the frequency offset of the modulated signal. The following figure shows the adjacent channel sensitivity test results.

real(RF_FSource)/(1 MHz)	real(RF_R)	real(Ior_Power_dBm)
2140.000	50.000	-92.700
real(Meas_FMeasurement)/(1 MHz)	real(Meas_R)	DPCH_Ec_dBm
2140.000	50.000	-103.000
EbN0_RF_dB		
30.693		

Meas BER Results

DTCH_AverageBER	DCCH_AverageBER	DPCH_AverageBER
0.000	0.000	0.000

3GPP Specification TS 25.101 (2000-12) Section 7.5

Specification requirements

Test results

The DTCH and DCCH BER shall not exceed 0.001 according to TS 25.101

Passed

Adjacent Channel Sensitivity Test Results

Blocking Characteristics

The blocking characteristics (defined in section 7.6 of TS25.101 [4]) are tested when MeasType is set to Blocking. Test conditions are:

Parameter	Unit	Test Case 1	Test Case 2
DPCH_Ec	dBm/3.84MHz	-114	-114
Ior	dBm/3.84MHz	-103.7	-103.7
Iblocking (modulated)	dBm/3.84MHz	-56	-44
Fuw (offset)	MHz	+10 or 10	±15

I blocking (modulated) consists of common channels and 16 dedicated data channels, and the frequency offset is F uw.

The following figure shows the blocking characteristics test results.

Advanced Design System 2008

real(RF_FSource)/(1 MHz)	real(RF_R)	real(Ior_Power_dBm)
2140.000	50.000	-103.700
real(Meas_FMeasurement)/(1 MHz)	real(Meas_R)	DPCH_Ec_dBm
2140.000	50.000	-114.000

EbNO_RF_dB
19.693

Meas BER Results

DTCH_AverageBER	DCCH_AverageBER	DPCH_AverageBER
0.000	0.000	0.000

3GPP Specification TS 25.101 (2000-12) Section 7.6

Specification requirements

The DTCH and DCCH BER shall not exceed 0.001 according to TS 25.101

Test results

Passed

Blocking Characteristics Test Results

Intermodulation Characteristics

Intermodulation characteristics (defined in section 7.8 of TS25.101 [4]) are tested when MeasType is set to Intermod. Test conditions are:

Parameter	Unit	Level
DPCH_Ec	dBm/3.84MHz	-114
Ior	dBm/3.84MHz	-103.7
Iouw1 (CW)	dBm	-46
Iouw2 (modulated)	dBm/3.84MHz	-46
Fuw1 (offset)	MHz	±10
Fuw2 (offset)	MHz	±20

In the RF channel, there are two intermodulation response signals that have a specific frequency relationship to the

requisite signal:

- By default, the continuous wave interference has a +10 MHz frequency offset from the central carrier frequency; its power is -46 dBm.
- By default, the modulated interfering signal has a +20 MHz offset from the central carrier frequency; its power is -46 dBm/3.84 MHz.

The following figure shows the intermodulation characteristics test results.

real(RF_FSource)/(1 MHz)	real(RF_R)	real(Ior_Power_dBm)
2140.000	50.000	-103.700
real(Meas_FMeasurement)/(1 MHz)	real(Meas_R)	DPCH_Ec_dBm
2140.000	50.000	-114.000
EbN0_RF_dB		
19.693		

Meas BER Results

DTCH_AverageBER	DCCH_AverageBER	DPCH_AverageBER
0.000	0.000	0.000

3GPP Specification TS 25.101 (2000-12) Section 7.8

Specification requirements

The DTCH and DCCH BER shall not exceed 0.001 according to TS 25.101

Test results

Passed

Intermodulation Characteristics Test Results

Test Bench Variables for Data Displays

The following table identifies the reference variables used to set up this test bench.

Test Bench Equations Derived from Test Bench Parameters and Exported to the Data Display

Data Display Parameter	Equation with Test Bench Parameters
------------------------	-------------------------------------

Advanced Design System 2008

Spec_Version	SpecVersion
RF_FSource	FSource
RF_R	SourceR
RF_SourceTemp	SourceTemp
Ior_Power_dBm	30 + 10 log(Ior_Power), where Ior_Power = RefLevel_Ior_Power, or MaxLevel_Ior_Power, or ACS_Ior_Power, or Blocking_Ior_Power, or Intermod_Ior_Power, according to MeasType setting.
DPCH_Ec_2_Ior_dB	RefLevel_DPCH_Ec_2_Ior, or MaxLevel_DPCH_Ec_2_Ior, or ACS_DPCH_Ec_2_Ior, or Blocking_DPCH_Ec_2_Ior, or Intermod_DPCH_Ec_2_Ior, according to MeasType setting.
ChipRate	3.84MChips/Second
SlotTime	0.667ms
FrameTime	10ms
TimeStep	1/(3.84e6*SamplesPerChip)
Meas_FMeasurement	FMeasurement
Meas_R	MeasR
FrameNum	FrameSetsMeasured * 4
ModFreq	FSource + ModFreqOffset, Where ModFreqOffset = ACS_ModFreqOffset, or Blocking_ModFreqOffset, or Intermod_ModFreqOffset, according to MeasType setting = ACS, Blocking, or Intermod.
ModePower_dBm	30 + 10 log (ModPower), where ModPower = ACS_ModPower, or Blocking_ModPower or Intermod_ModPower, according to MeasType setting = ACS, Blocking, or Intermod.
CWFreq	FSource + Intermod_CW_FreqOffset, valid when MeasType = Intermod
CWPower_dBm	30 + 10 log(Intermod_CW_Power), valid when MeasType = Intermod

Baseline Performance

- Test Computer Configuration
 - Pentium IV 2.4 GHz, 512 MB RAM, Red Hat Linux 7.3
- Conditions

Advanced Design System 2008

- Measurements made with default test bench settings.
- RF DUT is an RF system behavior component.
- The number of time points in one slot can be calculated by SamplesPerChip times ChipsPerSlot.
ChipRate = 3.84 MHz
SamplesPerChip = 8
ChipsPerSlot = 2560
1 FrameSet = 4 Frames
Resultant WTB_TimeStep = 32.6 nsec; SlotTime = 666.7 μ time points per slot = 20480
- Simulation times and memory requirements.

Measurement	FrameSets Measured	Simulation Time (sec)	ADS Processes (MB)
RefLevel	21	6273	121
MaxLevel	21	6148	100
ACS	21	6819	102
Blocking	21	6935	103
Intermod	21	7655	103

Expected ADS Performance

Expected ADS performance is the combined performance of the baseline test bench and the RF DUT Circuit Envelope simulation with the same signal and number of time points. For example, if the RF DUT performance with Circuit Envelope simulation alone takes 2 hours and consumes 200 MB of memory (excluding the memory consumed by the core ADS product), then add these numbers to the Baseline Performance numbers to determine the expected ADS performance. This is valid only if the full memory consumed is from RAM. If RAM is less, larger simulation times may result due to increased disk access time for swap memory usage.

References

1. 3GPP Technical Specification TS 25.211, "Physical channels and mapping of transport channels onto physical channels (FDD)" Release 1999.
http://www.3gpp.org/ftp/Specs/2002-03/R1999/25_series/25211-3a0.zip
2. 3GPP Technical Specification TS 25.212, "Multiplexing and Channel Coding (FDD)" Release 1999.
http://www.3gpp.org/ftp/Specs/2002-03/R1999/25_series/25212-390.zip
3. 3GPP Technical Specification TS 25.213, "Spreading and modulation (FDD)" Release 1999.
http://www.3gpp.org/ftp/Specs/2002-03/R1999/25_series/25213-370.zip
4. 3GPP Technical Specification TS 25.101, "UE Radio transmission and reception (FDD)" Release 1999.
http://www.3gpp.org/ftp/Specs/2002-03/R1999/25_series/25101-3a0.zip
5. 3GPP Technical Specification TS 34.121, "Terminal Conformance Specification, Radio Transmission and Reception (FDD)" Release 1999.
[http://www.3gpp.org/ftp/Specs/2002-03/R1999/34_series/34121-380.zip]"http://www.3gpp.org/ftp/Specs/2002-03/R1999/34_series/34121-380.zip]"

Setting up a Wireless Test Bench Analysis in the Wireless Test Bench Simulation documentation explains how to use test bench windows and dialogs to perform analysis tasks.

Setting Circuit Envelope Analysis Parameters in the Wireless Test Bench Simulation documentation explains how to set up circuit envelope analysis parameters such as convergence criteria, solver selection, and initial guess.

Setting Automatic Behavioral Modeling Parameters in the Wireless Test Bench Simulation documentation to learn how to improve simulation speed.

RF DUT Limitations for 3GPP FDD Wireless Test Benches

This appendix describes test bench use with typical RF DUTs, improving test bench performance when certain RF DUT types are used, and improving simulation fidelity. Two sections regarding special attention for Spectrum and EVM transmission measurements is also included.

The RF DUT, in general, may be a circuit design with any combination and quantity of analog and RF components, transistors, resistors, capacitors, etc. suitable for simulation with the Agilent Circuit Envelope simulator. More complex RF circuits will take more time to simulate and will consume more memory.

Test bench simulation time and memory requirements can be considered to be the combination of the requirements for the baseline test bench measurement with the simplest RF circuit plus the requirements for a Circuit Envelope simulation for the RF DUT of interest.

An RF DUT connected to a wireless test bench can generally be used with the test bench to perform default measurements by setting the test bench Required Parameters. Default measurement parameter settings can be used (exceptions described below), for a typical RF DUT that:

- Requires an input (RF) signal with constant RF carrier frequency.
The test bench RF signal source output does not produce an RF signal whose RF carrier frequency varies with time. However, the test bench will support an output (RF) signal that contains RF carrier phase and frequency modulation as can be represented with suitable I and Q envelope variations on a constant RF carrier frequency.
- Produces an output (Meas) signal with constant RF carrier frequency.
The test bench input (Meas) signal must not contain a carrier frequency whose frequency varies with time. However, the test bench will support an input (Meas) signal that contains RF carrier phase noise or contains time varying Doppler shifts of the RF carrier. These signal perturbations are expected to be represented with suitable I and Q envelope variations on a constant RF carrier frequency.
- Requires an input (RF) signal from a signal generator with a 50-ohm source resistance. Otherwise, set the SourceR parameter value in the Basic Parameters tab.
- Requires an input (RF) signal with no additive thermal noise (TX test benches) or source resistor temperature set to 16.85 o C (RX test benches). Otherwise, set the SourceTemp (TX and RX test benches) and EnableSourceNoise (TX test benches) parameters in the Basic Parameters tab.
- Requires an input (RF) signal with no spectrum mirroring. Otherwise, set the MirrorSourceSpectrum parameter

- value in the Basic Parameters tab.
- Produces an output (Meas) signal that requires a 50-ohm external load resistance. Otherwise, set the MeasR parameter value in the Basic Parameters tab.
 - Produces an output (Meas) signal with no spectrum mirroring. Otherwise, set the MirrorMeasSpectrum parameter value in the Basic Parameters tab.
 - Relies on the test bench for any measurement-related bandpass signal filtering of the RF DUT output (Meas) signal.
 - When the RF DUT contains a bandpass filter with bandwidth that is on the order of the test bench receiver system (~ 1 times the test bench receiver bandwidth) and the user wants a complete characterization of the RF DUT filter, the default time CE_TimeStep must be set smaller.
 - When the RF DUT bandpass filter is much wider than the test bench receiver system (> 2 times the test bench receiver bandwidth), the user may not want to use the smaller CE_TimeStep time step to fully characterize it because the user knows the RF DUT bandpass filter has little or no effect in the modulation bandwidth in this case.

Improving Test Bench Performance

This section provides information regarding improving test bench performance when certain RF DUT types are used.

- Analog/RF models (TimeDelay and all transmission line models) used with Circuit Envelope simulation that perform linear interpolation on time domain waveforms for modeling time delay characteristics that are not an integer number of CE_TimeStep units. Degradation is likely in some measurements, especially EVM. This limitation is due to the linear interpolation between two successive simulation time points, which degrades waveform quality and adversely affects EVM measurements.

To avoid this kind of simulator-induced waveform quality degradation: avoid use of Analog/RF models that rely on linear interpolation on time domain characteristics; or, reduce the test bench CE_TimeStep time step by a factor of 4 below the default CE_TimeStep (simulation time will be 4 times longer).
- Analog/RF lumped components (R, L, C) used to provide bandpass filtering with a bandwidth as small as the wireless signal RF information bandwidth are likely to cause degradation in some measurements, especially Spectrum. These circuit filters require much smaller CE_TimeStep values than would otherwise be required for RF DUT circuits with broader bandwidths.

This limitation is due to the smaller Circuit Envelope simulation time steps required to resolve the differential equations for the L, C components when narrow RF bandwidths are involved. Larger time steps degrade the resolution of the simulated bandpass filtering effects and do not result in accurate frequency domain measurements, especially Spectrum and EVM measurements (when the wireless technology is sensitive to frequency domain distortions).

To determine that your lumped component bandwidth filter requires smaller CE_TimeStep, first characterize your filter with Harmonic Balance simulations over the modulation bandwidth of interest centered at the carrier frequency of interest. Though it is difficult to identify an exact guideline on the Circuit Envelope time step required for good filter resolution, a reasonable rule is to set the CE_TimeStep to $1/(\text{double-sided 3dB bandwidth})/32$.

To avoid this kind of simulator-induced waveform quality degradation, avoid the use of R, L, C lumped filters with bandwidths as narrow as the RF signal information bandwidth, or reduce the CE_TimeStep.
- Analog/RF data-based models (such as S-parameters and noise parameters in S2P data files) used to provide RF bandpass filtering with a bandwidth as small as 1.5 times the wireless signal RF information bandwidth are likely to cause degradation in some measurements, especially EVM.

This limitation is due to causal S-parameter data about the signal carrier frequency requiring a sufficient number of frequency points within the modulation bandwidth; otherwise, the simulated data may cause degraded signal waveform quality. In general, there should be more than 20 frequency points in the modulation bandwidth; more is required if the filter that the S-parameter data represents has fine-grain variations at small frequency steps.

To avoid this kind of simulator-induced waveform quality degradation, avoid the use of data-based models with bandwidths as narrow as the RF signal information bandwidth, or increase the number of frequency points in the data file within the modulation bandwidth and possibly also reduce the CE_TimeStep simulation time step.

- An additional limitation exists when noise data is included in the data file. Circuit Envelope simulation technology does not provide frequency-dependent noise within the modulation bandwidth for this specific case when noise is from a frequency domain data file. This may result in output noise power that is larger than expected; if the noise power is large enough, it may cause degraded signal waveform quality.

To avoid this kind of simulator-induced waveform quality degradation avoid the use of noise data in the data-based models or use an alternate noise model.

Improving Simulation Fidelity

Some RF circuits will provide better Circuit Envelope simulation fidelity if the CE_TimeStep is reduced.

- In general, the default setting of the test bench SamplesPerChip provides adequate wireless signal definition and provides the WTB_TimeStep default value.
- Set $CE_TimeStep = 1/(3.84e6/SamplesPerChip \times N)$

where N is an integer ≥ 1

- When CE_TimeStep is less than the WTB_TimeStep (i.e., $N > 1$), the RF signal to the RF DUT is automatically upsampled from the WTB_TimeStep and the RF DUT output signal is automatically downsampled back to the WTB_TimeStep. This sampling introduces a time delay to the RF DUT of $10 \times WTB_TimeStep$ and a time delay of the measured RF DUT output signal of $20 \times WTB_TimeStep$ relative to the measured RF signal sent to the RF DUT prior to its upsampling.

Special Attention for Spectrum Measurements

The Spectrum Measurement spectrum may have a mask against which the spectrum must be lower in order to pass the wireless specification. The Spectrum measurement itself is based on DSP algorithms that result in as much as 15 dB low-level spectrum variation at frequencies far from the carrier.

To reduce this low-level spectrum variation, a moving average can be applied to the spectrum using the `moving_average(<data>, 20)` measurement expression for a 20-point moving average. This will give a better indication of whether the measured signal meets the low-level spectrum mask specification at frequencies far from the carrier.

Special Attention for EVM Measurements

For the EVM measurement, the user can specify a start time. The EVM for the initial wireless segment may be unusually high (due to signal startup transient effects or other reasons) that cause a mis-detected first frame that the user does not want included in the RF DUT EVM measurement.

To remove the degraded initial burst EVM values from the RF DUT EVM measurement, set the EVM_Start to a value greater than or equal to the RF DUT time delay characteristic.

Measurement Results for Expressions for 3GPP FDD Wireless Test Benches

Measurement results from a wireless test bench have associated names that can be used in Expressions. Those expressions can further be used in specifying goals for Optimization and Monte Carlo/Yield analysis. For details on using expressions, see the [Measurement Expressions](#) documentation. For details on setting analysis goals using Optimization and Monte Carlo/Yield analysis, see the [Tuning, Optimization, and Statistical Design](#) documentation.

You can use an expression to determine the measurement result independent variable name and its minimum and maximum values. The following example expressions show how to obtain these measurement details where MeasResults is the name of the measurement result of interest:

- The Independent Variable Name for this measurement result is obtained by using the expression `indep(MeasResults)`
- The Minimum Independent Variable Value for this measurement result is obtained by using the expression `min(indep(MeasResults))`
- The Maximum Independent Variable Value for this measurement result is obtained by using the expression `max(indep(MeasResults))`

The following tables list the measurement result names and independent variable name for each test bench measurement. Expressions defined in a MeasEqn block must use the full Measurement Results Name listed. Expressions used in the Data Display may omit the leading test bench name. You can also locate details on the measurement result minimum and maximum independent variable values by

- Referring to the measurement parameter descriptions when they are available (not all measurement parameter descriptions identify these minimum and maximum values).
- Observing the minimum and maximum independent variable values in the Data Display for the measurement.

Advanced Design System 2008

Measurement Results Name	Independent Variable Name
Envelope	
3GPPFDD_BS_TX.RF_V	time
3GPPFDD_BS_TX.Meas_V	time
Power	
3GPPFDD_BS_TX.RF_Power.CCDF.CCDF	Index
3GPPFDD_BS_TX.RF_Power.CCDF.MeanPower_dBm	Index
3GPPFDD_BS_TX.RF_Power.CCDF.PeakPower_dBm	Index
3GPPFDD_BS_TX.RF_Power.CCDF.SignalRange_dB	Index
3GPPFDD_BS_TX.Meas_Power.CCDF.CCDF	Index
3GPPFDD_BS_TX.Meas_Power.CCDF.MeanPower_dBm	Index
3GPPFDD_BS_TX.Meas_Power.CCDF.PeakPower_dBm	Index
3GPPFDD_BS_TX.Meas_Power.CCDF.SignalRange_dB	Index
ACLR	
3GPPFDD_BS_TX.RF_ACLR.Spec_Out_L10	freq
3GPPFDD_BS_TX.RF_ACLR.Spec_Out_L5	freq
3GPPFDD_BS_TX.RF_ACLR.Spec_Out_Main	freq
3GPPFDD_BS_TX.RF_ACLR.Spec_Out_U5	freq
3GPPFDD_BS_TX.RF_ACLR.Spec_Out_U10	freq
3GPPFDD_BS_TX.Meas_ACLR.Spec_Out_L10	freq
3GPPFDD_BS_TX.Meas_ACLR.Spec_Out_L5	freq
3GPPFDD_BS_TX.Meas_ACLR.Spec_Out_Main	freq
3GPPFDD_BS_TX.Meas_ACLR.Spec_Out_U5	freq
3GPPFDD_BS_TX.Meas_ACLR.Spec_Out_U10	freq
Occupied Bandwidth	
3GPPFDD_BS_TX.RF_OBW.Spec_Out	freq
3GPPFDD_BS_TX.Meas_OBW.Spec_Out	freq
CDP	
3GPPFDD_BS_TX.RF_CDP.CodeDomainPwr.CDP_CodeIndex	Index
3GPPFDD_BS_TX.RF_CDP.CodeDomainPwr.CodeDomainPwr	Index

Advanced Design System 2008

3GPPFDD_BS_TX.Meas_CDP.CodeDomainPwr.CDP_CodeIndex	Index
3GPPFDD_BS_TX.Meas_CDP.CodeDomainPwr.CodeDomainPwr	Index
PCDE	
3GPPFDD_BS_TX.RF_PCDE.CodeDomainErr.CDE_CodeIndex	Index
3GPPFDD_BS_TX.RF_PCDE.CodeDomainErr.I_CDE	Index
3GPPFDD_BS_TX.RF_PCDE.CodeDomainErr.Q_CDE	Index
3GPPFDD_BS_TX.Meas_PCDE.CodeDomainErr.CDE_CodeIndex	Index
3GPPFDD_BS_TX.Meas_PCDE.CodeDomainErr.I_CDE	Index
3GPPFDD_BS_TX.Meas_PCDE.CodeDomainErr.Q_CDE	Index
EVM	
3GPPFDD_BS_TX.RF_EVM.EVM.EVM	Index
3GPPFDD_BS_TX.Meas_EVM.EVM.EVM	Index

3GPPFDD_UE_TX Measurement Results

Measurement Results Name	Independent Variable Name
Envelope	
3GPPFDD_UE_TX.RF_V	time
3GPPFDD_UE_TX.Meas_V	time
Power	
3GPPFDD_UE_TX.RF_Power.CCDF.CCDF	Index
3GPPFDD_UE_TX.RF_Power.CCDF.MeanPower_dBm	Index
3GPPFDD_UE_TX.RF_Power.CCDF.PeakPower_dBm	Index
3GPPFDD_UE_TX.RF_Power.CCDF.SignalRange_dB	Index
3GPPFDD_UE_TX.Meas_Power.CCDF.CCDF	Index
3GPPFDD_UE_TX.Meas_Power.CCDF.MeanPower_dBm	Index
3GPPFDD_UE_TX.Meas_Power.CCDF.PeakPower_dBm	Index
3GPPFDD_UE_TX.Meas_Power.CCDF.SignalRange_dB	Index
ACLR	
3GPPFDD_UE_TX.RF_ACLR.Spec_Out_L10	freq
3GPPFDD_UE_TX.RF_ACLR.Spec_Out_L5	freq

Advanced Design System 2008

3GPPFDD_UE_TX.RF_ACLR.Spec_Out_Main	freq
3GPPFDD_UE_TX.RF_ACLR.Spec_Out_U5	freq
3GPPFDD_UE_TX.RF_ACLR.Spec_Out_U10	freq
3GPPFDD_UE_TX.Meas_ACLR.Spec_Out_L10	freq
3GPPFDD_UE_TX.Meas_ACLR.Spec_Out_L5	freq
3GPPFDD_UE_TX.Meas_ACLR.Spec_Out_Main	freq
3GPPFDD_UE_TX.Meas_ACLR.Spec_Out_U5	freq
3GPPFDD_UE_TX.Meas_ACLR.Spec_Out_U10	freq
ACLR_SwitchingTransients	
3GPPFDD_UE_TX.RF_ACLR_SwitchingTransients.L10.AverageBlockPower	freq
3GPPFDD_UE_TX.RF_ACLR_SwitchingTransients.L10.AverageTotalPower	freq
3GPPFDD_UE_TX.RF_ACLR_SwitchingTransients.L5.AverageBlockPower	freq
3GPPFDD_UE_TX.RF_ACLR_SwitchingTransients.L5.AverageTotalPower	freq
3GPPFDD_UE_TX.RF_ACLR_SwitchingTransients.Main.AverageBlockPower	freq
3GPPFDD_UE_TX.RF_ACLR_SwitchingTransients.Main.AverageTotalPower	freq
3GPPFDD_UE_TX.RF_ACLR_SwitchingTransients.U5.AverageBlockPower	freq
3GPPFDD_UE_TX.RF_ACLR_SwitchingTransients.U5.AverageTotalPower	freq
3GPPFDD_UE_TX.RF_ACLR_SwitchingTransients.U10.AverageBlockPower	freq
3GPPFDD_UE_TX.RF_ACLR_SwitchingTransients.U10.AverageTotalPower	freq
3GPPFDD_UE_TX.Meas_ACLR_SwitchingTransients.L10.AverageBlockPower	freq
3GPPFDD_UE_TX.Meas_ACLR_SwitchingTransients.L10.AverageTotalPower	freq
3GPPFDD_UE_TX.Meas_ACLR_SwitchingTransients.L5.AverageBlockPower	freq
3GPPFDD_UE_TX.Meas_ACLR_SwitchingTransients.L5.AverageTotalPower	freq
3GPPFDD_UE_TX.Meas_ACLR_SwitchingTransients.Main.AverageBlockPower	freq
3GPPFDD_UE_TX.Meas_ACLR_SwitchingTransients.Main.AverageTotalPower	freq
3GPPFDD_UE_TX.Meas_ACLR_SwitchingTransients.U5.AverageBlockPower	freq
3GPPFDD_UE_TX.Meas_ACLR_SwitchingTransients.U5.AverageTotalPower	freq
3GPPFDD_UE_TX.Meas_ACLR_SwitchingTransients.U10.AverageBlockPower	freq
3GPPFDD_UE_TX.Meas_ACLR_SwitchingTransients.U10.AverageTotalPower	freq
Occupied Bandwidth	

Advanced Design System 2008

3GPPFDD_UE_TX.RF_OccupiedBW.Spec_Out	freq
3GPPFDD_UE_TX.Meas_OccupiedBW.Spec_Out	freq
CDP	
3GPPFDD_UE_TX.RF_CDP.CodeDomainPwr.CDP_CodeIndex	Index
3GPPFDD_UE_TX.RF_CDP.CodeDomainPwr.CodeDomainPwr	Index
3GPPFDD_UE_TX.Meas_CDP.CodeDomainPwr.CDP_CodeIndex	Index
3GPPFDD_UE_TX.Meas_CDP.CodeDomainPwr.CodeDomainPwr	Index
PCDE	
3GPPFDD_UE_TX.RF_PCDE.CodeDomainErr.CDE_CodeIndex	Index
3GPPFDD_UE_TX.RF_PCDE.CodeDomainErr.I_CDE	Index
3GPPFDD_UE_TX.RF_PCDE.CodeDomainErr.Q_CDE	Index
3GPPFDD_UE_TX.Meas_PCDE.CodeDomainErr.CDE_CodeIndex	Index
3GPPFDD_UE_TX.Meas_PCDE.CodeDomainErr.I_CDE	Index
3GPPFDD_UE_TX.Meas_PCDE.CodeDomainErr.Q_CDE	Index
EVM	
3GPPFDD_UE_TX.RF_EVM.EVM.EVM	Index
3GPPFDD_UE_TX.Meas_EVM.EVM.EVM	Index

3GPPFDD_BS_RX Measurement Results

Measurement Results Name	Independent Variable Name
3GPPFDD_BS_RX.Meas_BER.DCCHbits	Index
3GPPFDD_BS_RX.Meas_BER.DCCH_BER	Index
3GPPFDD_BS_RX.Meas_BER.DCCH_BLER	Index
3GPPFDD_BS_RX.Meas_BER.DPDCHbits	Index
3GPPFDD_BS_RX.Meas_BER.DPDCH_BER	Index
3GPPFDD_BS_RX.Meas_BER.DTCHbits	Index
3GPPFDD_BS_RX.Meas_BER.DTCH_BER	Index
3GPPFDD_BS_RX.Meas_BER.DTCH_BLER	Index
3GPPFDD_BS_RX.Meas_BER.RefDCCHbits	Index
3GPPFDD_BS_RX.Meas_BER.RefDPDCHbits	Index
3GPPFDD_BS_RX.Meas_BER.RefDTCHbits	Index

Advanced Design System 2008

3GPPFDD_UE_RX Measurement Results

Measurement Results Name	Independent Variable Name
3GPPFDD_UE_RX.Meas_Measurement.DCCHbits	Index
3GPPFDD_UE_RX.Meas_Measurement.DCCH_BER	Index
3GPPFDD_UE_RX.Meas_Measurement.DCCH_BLER	Index
3GPPFDD_UE_RX.Meas_Measurement.DPCHbits	Index
3GPPFDD_UE_RX.Meas_Measurement.DPCH_BER	Index
3GPPFDD_UE_RX.Meas_Measurement.DTCHbits	Index
3GPPFDD_UE_RX.Meas_Measurement.DTCH_BER	Index
3GPPFDD_UE_RX.Meas_Measurement.DTCH_BLER	Index
3GPPFDD_UE_RX.Meas_Measurement.RefDCCHbits	Index
3GPPFDD_UE_RX.Meas_Measurement.RefDPCHbits	Index
3GPPFDD_UE_RX.Meas_Measurement.RefDTCHbits	Index