



Agilent Technologies

ADS 2008
January 2008
System Models

Advanced Design System 2008

© Agilent Technologies, Inc. 2000-2008

395 Page Mill Road, Palo Alto, CA 94304 U.S.A.

No part of this manual may be reproduced in any form or by any means (including electronic storage and retrieval or translation into a foreign language) without prior agreement and written consent from Agilent Technologies, Inc. as governed by United States and international copyright laws.

Acknowledgments

Mentor Graphics is a trademark of Mentor Graphics Corporation in the U.S. and other countries. Microsoft®, Windows®, MS Windows®, Windows NT®, and MS-DOS® are U.S. registered trademarks of Microsoft Corporation. Pentium® is a U.S. registered trademark of Intel Corporation. PostScript® and Acrobat® are trademarks of Adobe Systems Incorporated. UNIX® is a registered trademark of the Open Group. Java™ is a U.S. trademark of Sun Microsystems, Inc. SystemC® is a registered trademark of Open SystemC Initiative, Inc. in the United States and other countries and is used with permission. MATLAB® is a U.S. registered trademark of The Math Works, Inc.. HiSIM2 source code, and all copyrights, trade secrets or other intellectual property rights in and to the source code in its entirety, is owned by Hiroshima University and STARC.

Errata The ADS product may contain references to "HP" or "HPEESOF" such as in file names and directory names. The business entity formerly known as "HP EEsof" is now part of Agilent Technologies and is known as "Agilent EEsof". To avoid broken functionality and to maintain backward compatibility for our customers, we did not change all the names and labels that contain "HP" or "HPEESOF" references.

Warranty The material contained in this document is provided "as is", and is subject to being changed, without notice, in future editions. Further, to the maximum extent permitted by applicable law, Agilent disclaims all warranties, either express or implied, with regard to this manual and any information contained herein, including but not limited to the implied warranties of merchantability and fitness for a particular purpose. Agilent shall not be liable for errors or for incidental or consequential damages in connection with the furnishing, use, or performance of this document or of any information contained herein. Should Agilent and the user have a separate written agreement with warranty terms covering the material in this document that conflict with these terms, the warranty terms in the separate agreement shall control.

Technology Licenses The hardware and/or software described in this document are furnished under a license and may be used or copied only in accordance with the terms of such license. Portions of this product include the SystemC software licensed under Open Source terms, which are available for download at <http://systemc.org/>. This software is redistributed by Agilent. The Contributors of the SystemC software provide this software "as is" and offer no warranty of any kind, express or implied, including without limitation warranties or conditions or title and non-infringement, and implied warranties or conditions merchantability and fitness for a particular purpose. Contributors shall not be liable for any damages of any kind including without limitation direct, indirect, special, incidental and consequential damages, such as lost profits. Any provisions that differ from this disclaimer are offered by Agilent only.

Restricted Rights Legend If software is for use in the performance of a U.S. Government prime contract or subcontract, Software is delivered and licensed as "Commercial computer software" as defined in DFAR 252.227-7014 (June 1995), or as a "commercial item" as defined in FAR 2.101(a) or as "Restricted computer software" as defined in FAR 52.227-19 (June 1987) or any equivalent agency regulation or contract clause. Use, duplication or disclosure of Software is subject to Agilent Technologies' standard commercial license terms, and non-DOD Departments and Agencies of the U.S. Government will receive no greater than Restricted Rights as defined in FAR 52.227-19(c)(1-2) (June 1987). U.S. Government users will receive no greater than Limited Rights as defined in FAR 52.227-14 (June 1987) or DFAR 252.227-7015 (b)(2) (November 1995), as applicable in any technical data.

Contents

- Amplifiers and Mixers
 - ◦ Introduction
 - Curve-Fitting Algorithm
 - AGC_Amp (Voltage-Controlled Amplifier for AGC loops)
 - AGC_PwrControl (Power Control Block for AGC loops)
 - Amplifier (Obsolete RF System Amplifier)
 - Amplifier2 (RF System Amplifier)
 - AmplifierVC (Ideal Voltage-Controlled Amplifier)
 - AmpSingleCarrier (Single Carrier Amplifier)
 - FreqMult (Ideal Frequency Multiplier)
 - LogACDemod (Demodulating AC Logarithmic Amplifier)
 - LogDC (DC Logarithmic Amplifier)
 - LogSuccDetect (Successive Detection Logarithmic Amplifier)
 - LogTrue (True Logarithmic Amplifier)
 - Mixer (First RF System Mixer, Polynomial Model for Nonlinearity)
 - Mixer2 (RF System Mixer)
 - MixerWithLO (Mixer with Internal Local Oscillator)
 - OpAmp (Operational Amplifier)
 - OpAmpIdeal (Ideal Operational Amplifier)
 - VMult (Voltage Multiplier)
- Filters for System Models
 - ◦ Introduction
 - Filter Categories
 - - Lowpass Filter Behavior at DC
 - References
 - BPF_Bessel (Bandpass Filter, Bessel-Thompson)
 - BPF_Butterworth (Bandpass Filter, Butterworth)
 - BPF_Chebyshev (Bandpass Filter, Chebyshev)
 - BPF_Elliptic (Bandpass Filter, Elliptic)
 - BPF_Gaussian (Bandpass Filter, Gaussian)
 - BPF_PoleZero (Bandpass Filter, Pole Zero)
 - BPF_Polynomial (Bandpass Filter, Polynomial)
 - BPF_RaisedCos (Bandpass Filter, Raised-Cosine)
 - BSF_Bessel (Bandstop Filter, Bessel-Thompson)
 - BSF_Butterworth (Bandstop Filter, Butterworth)
 - BSF_Chebyshev (Bandstop Filter, Chebyshev)
 - BSF_Elliptic (Bandstop Filter, Elliptic)
 - BSF_Gaussian (Bandstop Filter, Gaussian)
 - BSF_PoleZero (Bandstop Filter, Pole Zero)
 - BSF_Polynomial (Bandstop Filter, Polynomial)
 - BSF_RaisedCos (Bandstop Filter, Raised-Cosine)
 - HPF_Bessel (Highpass Filter, Bessel-Thompson)
 - HPF_Butterworth (Highpass Filter, Butterworth)
 - HPF_Chebyshev (Highpass Filter, Chebyshev)
 - HPF_Elliptic (Highpass Filter, Elliptic)
 - HPF_Gaussian (Highpass Filter, Gaussian)

- HPF_PoleZero (Highpass Filter, Pole Zero)
- HPF_Polynomial (Highpass Filter, Polynomial)
- HPF_RaisedCos (Highpass Filter, Raised-Cosine)
- LPF_Bessel (Lowpass Filter, Bessel-Thompson)
- LPF_Butterworth (Lowpass Filter, Butterworth)
- LPF_Chebyshev (Lowpass Filter, Chebyshev)
- LPF_Elliptic (Lowpass Filter, Elliptic)
- LPF_Gaussian (Lowpass Filter, Gaussian)
- LPF_GMSK (Lowpass Filter, GMSK)
- LPF_PoleZero (Lowpass Filter, Pole Zero)
- LPF_Polynomial (Lowpass Filter, Polynomial)
- LPF_RaisedCos (Lowpass Filter, Raised-Cosine)
- SAW_Filter (Saw Filter)
- Modulators and Demodulators
 - Introduction
 - AM_DemodTuned (AM Demodulator, Tuned)
 - AM_ModTuned (AM Modulator, Tuned)
 - FM_DemodTuned (FM Demodulator, Tuned)
 - FM_ModTuned (FM Modulator, Tuned)
 - N_StateDemod (N-State Demodulator)
 - N_StateMod (N-State Modulator)
 - PM_DemodTuned (PM Demodulator, Tuned)
 - PM_ModTuned (PM Modulator, Tuned)
 - PM_UnwrapDemodTuned (PM Unwrapped Demodulator, Tuned)
 - QPSK_ModTuned (QPSK Modulator, Tuned)
- Passive System Components
 - AntLoad (Antenna Load)
 - Attenuator (Attenuator)
 - Balun3Port (Balun, 3-port)
 - Balun4Port (Balun, 4-port)
 - Balun6Port (Balun, 6-port)
 - Circulator (Ideal 3-Port Circulator)
 - CouplerDual (Dual Coupler)
 - CouplerSingle (Single Coupler)
 - Gyrator (Gyrator)
 - Hybrid90 (Ideal 90-degree Hybrid Coupler)
 - Hybrid180 (Ideal 180-degree Hybrid Coupler)
 - IsolatorSML (SMLIsolator)
 - LOS_Link (Line-Of-Sight Antenna Link)
 - Pad (Pi or Tee Format)
 - PhaseShiftSML (Phase Shifter)
 - PwrSplit2 (2-Way Power Splitter)
 - PwrSplit3 (3-Way Power Splitter)
 - TimeDelay (Time Delay)
 - Transformer (Ideal 4-Port Transformer)
 - TransformerG (Transformer with Ground Reference)
 - TwoPort (2-Port Model)
- Phase Lock Loop Components
 - DivideByN (Divide by N)
 - PhaseFreqDet (Frequency Detector, Baseband)

Advanced Design System 2008

- PhaseFreqDet2 (Frequency Detector, Baseband)
- PhaseFreqDetCP (Frequency Detector, Baseband with Charge Pump)
- PhaseFreqDetTuned (Phase Frequency Detector, Tuned)
- PhaseNoiseMod (Phase Noise Modulator)
- VCO (Voltage Controlled Oscillator)
- VCO_DivideByN (VCO Divide By N)
- Switch and Algorithmic Components
 - Comparator (Comparator)
 - ClockLFSR (Linear Feedback Shift Register)
 - Differentiator (Differentiator)
 - DPDT_Static (Double Pole Double Throw Switch, Static)
 - IntegratorSML (Integrator)
 - LimiterSML (Limiter)
 - ParallelSerial (Parallel to Serial Shift Register)
 - PathSelect2 (Coordinated set of Single Pole Double Throw Static Switches)
 - QuantizerSML (Quantizer)
 - ResetSwitch (Reset Switch)
 - SampleHoldSML (Sample Hold)
 - Sampler (Sampler)
 - SerialParallel (Serial to Parallel Shift Register)
 - SPDT_Dynamic (Single Pole Double Throw Switch, Dynamic)
 - SPDT_Static (Single Pole Double Throw Switch, Static)
 - SwitchV (Voltage Controlled Switch)
 - SwitchV_Model (Voltage Controlled Switch Model)
 - VSum (Voltage Summer)
- Tx/Rx Subsystems
 - RF_PA_CKT (RF Power Amplifier Circuit)
 - RF_RX_SML (RF Receiver)
 - RF_TX_SML (RF Transmitter)
- System Data Models
 - Classification of ADS System Data Models
 - AmpH1H2 (Amplifier/Fundamental and 2nd Harmonic vs. Input Power)
 - AmpH1H2_Setup (Amplifier/Fundamental and 2nd Harmonic vs. Input Power Setup)
 - AmplifierP2D (P2D File Amplifier, FDD-Based, for Single Carrier Signal)
 - AmplifierP2D_Setup (Extractor Component for AmplifierP2D)
 - AmplifierS2D (S2D File Amplifier, Polynomial Model for Nonlinearity)
 - AmplifierS2D_Setup (Extractor Component for AmplifierS2D)
 - AmpLoadPull (SDD Load-Pull Amplifier)
 - Balun3Port (Balun, 3-port)
 - Balun4Port (Balun, 4-port)
 - IQ_Demod_Data (IQ Demodulator Behavioral Model)
 - IQ_Demod_Setup (IQ Demodulator Setup)
 - IQ_Mod_Data (IQ Modulator Behavioral Model)
 - IQ_Mod_Setup (IQ Modulator Setup)
 - LoadPullSetup (Load Pull Setup)
 - MixerHBdata (2-Tone HB Mixer)
 - MixerHBsetup (2-Tone HB Mixer Setup)
 - MixerIMT (Obsolete Intermodulation Table Mixer)
 - MixerIMT2 (Intermodulation Table Mixer)
 - MixIMT_Data (Multi-RF Intermodulation Table Mixer Data Model)

- MixIMTA_Setup (Single-RF Intermodulation Table Extractor)
- MixIMTB_Setup (Multi-RF Intermodulation Table Extractor)
- VCA_Data (Voltage Controlled Amplifier)
- VCA_Setup (Voltage Controlled Amplifier Setup)

Amplifiers and Mixers

Introduction

The Filters - < filter type > and System - < device type > palettes contain two fundamentally different types of behavioral system models.

Filters , System - Amps & Mixers , and System - Mod/Demod can be classified as tops-down system models that support a tops-down system design flow where model behaviors are characterized by a small number of independent parameters such as frequency, power and load. They are often referred to as parameter-based behavioral models . System - Data Models can be classified as bottoms-up system models that support a bottoms-up verification flow where model behaviors are extracted from a simulation (or measurement) of a transistor-level circuit. They are often referred to as data-based behavioral models .

The parameter-based behavioral models typically provide superior speed relative to the data-based behavioral models with both of these being vastly superior to a brute-force transistor-level simulation.

The data-based behavioral models typically provide superior accuracy relative to the parameter-based behavioral models as they capture actual behaviors of implemented circuit components and not just design specifications.

The differences between parameter - and data-based behavioral models justify a palette emphasis on flow (all data-based behavioral models grouped together) rather than functionality (all amplifiers, mixers, modulators, and demodulators grouped together) and resulted in the addition of a System - Data Models palette.

The use model for parameter-based behavioral models is to simply set a series of parameters prior to using the model. The use model for data-based behavioral models is slightly more involved. For a discussion, refer to Chapter 8, System Data Models.

Curve-Fitting Algorithm

The curve-fitting algorithm to determine the nonlinear behavior of the system mixer models is based on fitting a polynomial to the specified data where the saturation power (P_{sat}) is calculated when the derivative of this polynomial is zero.

$$P_n(x) = a_1*x^1 + a_2*x^2 + a_3*x^3 + \dots$$

It is important to note that the coefficients a₄, a₆, a₈, ... are always zero. In only one case a₂ is non-zero and that's when SOI and TOI are specified.

Parameters	Order
------------	-------

TOI	3
TOI & AM2PM	3
SOI & TOI	$3 a_2 \neq 0$
PndB	3
PndB & AM2PM	3
Psat	5
TOI & PndB	5
PndB & Psat	7
TOI & Psat	7
PndB & TOI & Psat	9

AGC_Amp (Voltage-Controlled Amplifier for AGC loops)

Symbol

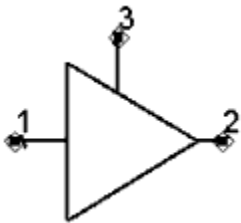

Available in ADS

Parameters

Name	Description	Units	Default
ZRef	Reference resistance for all ports	Ohm	50
S11	Forward reflection coefficient, use $x + j \times y$, $\text{polar}(x,y)$, $\text{dbpolar}(x,y)$,	None	$\text{polar}(0,0)$

Advanced Design System 2008

	vswrpolar(x,y) for complex value		
S22	Reverse reflection coefficient, use $x + j \times y$, polar(x,y), dbpolar(x,y), vswrpolar(x,y) for complex value	None	polar(0,180)
Min_dB	Minimum gain; occurs when $_v3 = \text{Min_dB}$ volt	dB	-40
Max_dB	Maximum gain; occurs when $_v3 = \text{Max_dB}$ volt	dB	40
NF	Noise Figure [NF mode used for NFmin=0]	dB	0
SOI	Second Order Intercept	dBm	1000
TOI	Third Order Intercept	dBm	1000

Range of Usage

$Z_{\text{Ref}} > 0$
 $|S_{ij}| > 0$ (ij=11; 22)
 $\text{Min_dB} < \text{Max_dB}$
 $\text{NF} \geq 0$ dB

Notes/Equations

1. AGC_Amp is a voltage-controlled amplifier with user-defined input and output reflection coefficients, minimum and maximum gain limits, and nonlinearity.
2. This component uses internal components TwoPort, Noisy2Port, AmplifierVC, and Amplifier2, as shown in the schematic.

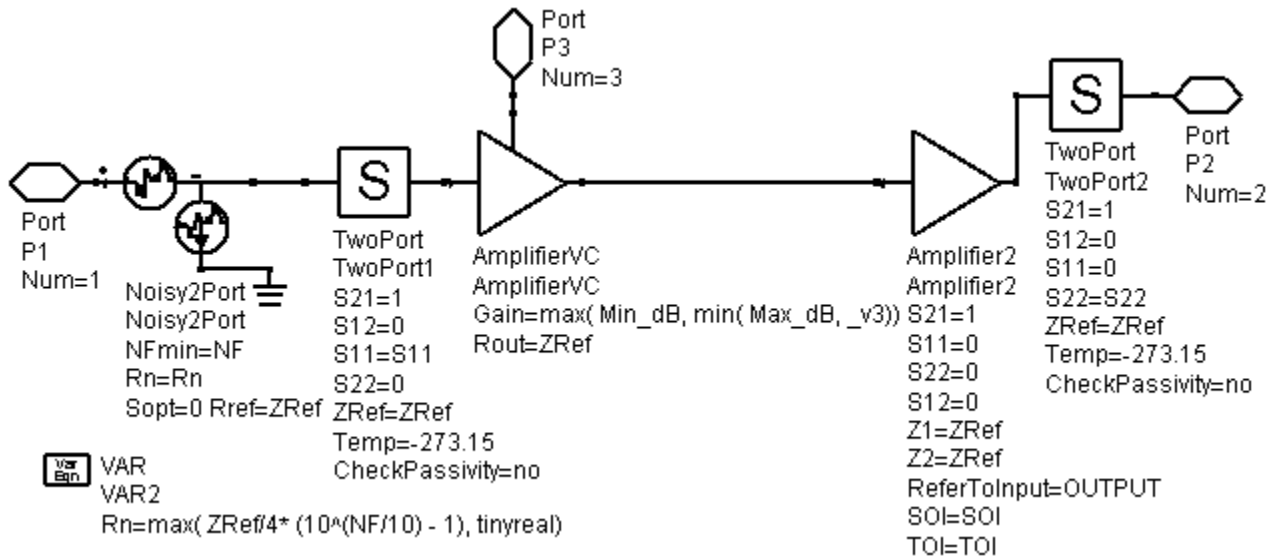

3. Control voltage at pin 3 is used to set gain. Under small signal conditions, gain in dB as a function of the control voltage at port 3: $_v3$ is:
Gain_dB = max(Min_dB, min(Max_dB, $_v3$))
4. The input impedance at pin 3 is infinite.
5. Regarding NF, component noise parameters (NFmin, Rn, Sopt) are related to NF by setting NFmin=NF, Sopt=0, and Rn=max(ZRef/4 × (10 NF/10 - 1), tinyreal), where tinyreal is an internal simulator value for the smallest real value allowed.
6. Regarding SOI and TOI, AGC_Amp must be output-matched in order to validate SOI and TOI. By default, SOI and TOI are blank resulting in no nonlinearity. TOI can be set without setting SOI; if SOI is set, TOI must be set.
For more information about SOI and TOI, refer to Amplifier2 documentation.
7. AGC_Amp is required for defining AGC control loops in designs to be simulated with Budget Controller. Such Budget simulation requires AGC_PwrControl; refer to AGC_PwrControl for AGC control loop usage details.
8. Example designs demonstrating AGC_Amp in AGC control loops are located in ADS; access the designs from the ADS Main window: File > Example Project > Tutorial > RF_Budget_Examples_prj ; see Budget_AGC.dsn and AGC_loop_CE_test.dsn .

AGC_PwrControl (Power Control Block for AGC loops)

Symbol

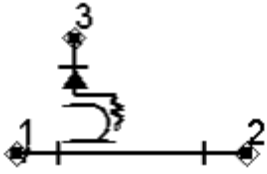

Available in ADS

Parameters

Name	Description	Units	Default
ZRef	Reference impedance for ports 1 and 2	Ohm	50
S11	Port 1 reflection coefficient, complex number	None	polar(0,0)
S22	Port 2 reflection coefficient, complex number	None	polar(0,180)
Fnom	Nominal input frequency for detection and power control	GHz	1
TargetPwr	Target power output level	dBm	10
BW	Closed loop -3dB frequency	kHz	4.5
DampingFactor	Loop damping factor	None	0.707
NormalizedZero	Loop normalized zero	None	1
ExternalGain	Open loop gain (voltage ratio) external to this block	None	0.025

Range of Usage

- ZRef > 0
- | S_{ij} | > 0 (ij=11; 22)
- Fnom > 0
- TargetPower > 0 (Watts)
- BW > 0
- DampingFactor > 0

NormalizedZero > 0
 ExternalGain > 0

Notes/Equations

1. AGC_PwrControl is used with AGC control loops; it incorporates an OpAmp loop filter with output at pin 3 for driving a preceding AGC amplifier toward the gain required to achieve the TargetPwr level at the AGC_PwrControl input.
2. This component uses internal components IQ_DemodTuned, FDD (used as a log amp), and OpAmp active filter, as shown in the schematic.

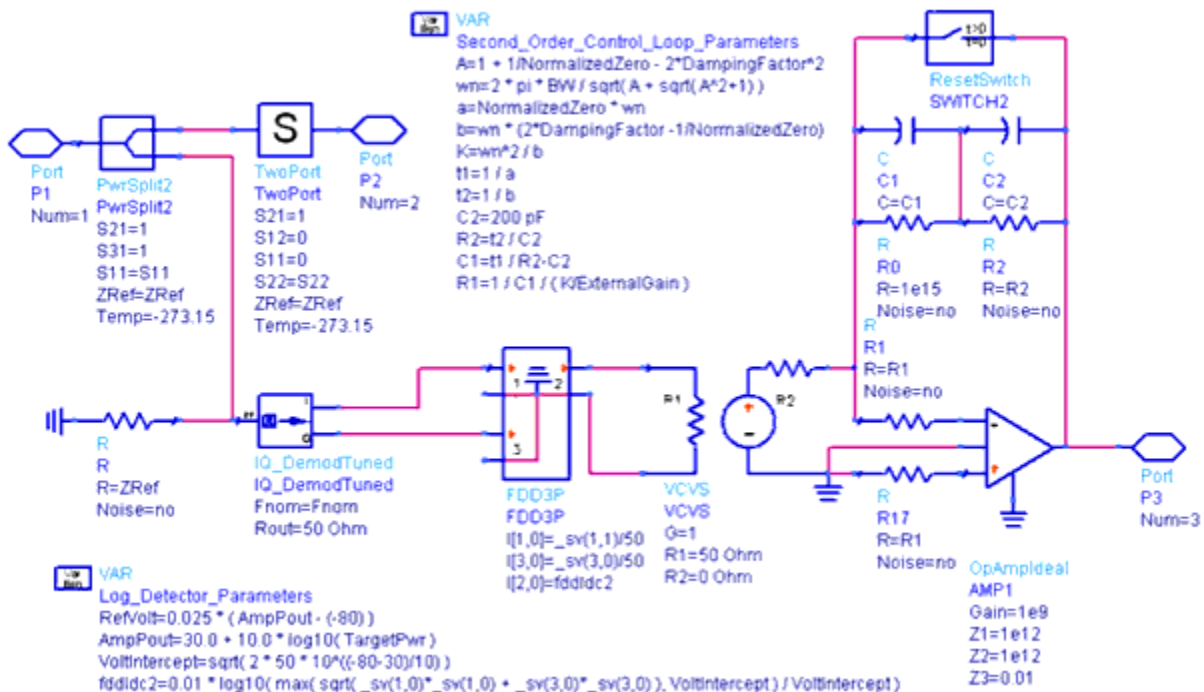

3. The control voltage at pin 3 is used for feedback to an AGC amplifier (pin 3 of AGC_Amp) to achieve an RF amplitude control loop.
4. AGC_PwrControl depends on time-varying RF waveforms, so it is typically used for Envelope simulations when an input modulated RF signal exists at Fnom.
5. For Budget simulations, AGC_PwrControl is used with AGC_Amp to define AGC loops. Budget simulation AGC control loops work with one tone and only the steady state value of the loop is used. For Budget simulations, Fnom, BW, DampingFactor, NormalizedZero, and ExternalGain parameters are not used.
6. The time-domain RF control loop behavior is defined for second-order control loop operation in which the OpAmp loop filter internal to this model establishes the second-order control loop filter characteristics for the combined circuit external to AGC_PwrControl plus AGC_PwrControl.
7. The control loop drives the external AGC amplifier to a gain level that is sufficient for maintaining the output power of the AGC system at the user-specified value of TargetPwr.
8. Loop dynamics follow second-order control loop theory whereby the user defines TargetPwr, -3 dB closed loop bandwidth (BW), loop gain external to AGC_PwrControl, and second-order loop parameters (NormalizedZero and DampingFactor) and AGC_PwrControl sets the internal OpAmp reference voltage (RefVolt) and loop filter capacitance and resistance values (R1, R2, C1, C2). Refer to the schematic for the defining equations.

AGC_PwrControl uses a log detector defined by use of an FDD model.

9. For HarmonicBalance use, this model behavior defaults with output of a DC signal voltage at pin 3 equal to the reference voltage at the non-inverting input of the internal OpAmp.
10. The output impedance at pin 3 is zero.
11. For details regarding second-order loop theory, refer to the Second-Order Control Loop Filters section in chapter 2 of [Timed Components](#) documentation.
12. Example designs demonstrating AGC_PwrControl in AGC control loops are located in ADS; access the designs from the ADS Main window: File > Example Project > Tutorial > RF_Budget_Examples_prj ; see Budget_AGC.dsn and AGC_loop_CE_test.dsn .

Amplifier (Obsolete RF System Amplifier)

Symbol

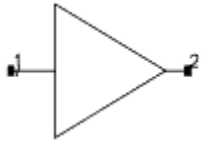

Note
 2003C introduces an improved version of Amplifier: Amplifier2. Please use Amplifier2 for new designs; refer to Amplifier2 documentation for more information.

Available in ADS

Parameters

Name	Description	Units	Default
S21	Forward transmission gain (real or complex number; refer to note 2)	None	None
S11	Port 1 reflection (real or complex number; refer to note 2)	None	None
S22	Port 2 reflection (real or complex number; refer to note 2)	None	None

Advanced Design System 2008

	note 2)		
S12	Reverse transmission gain (real or complex number; refer to note 2)	None	None
NF	Input noise figure	dB	None
NFmin	Minimum noise figure at Sopt	dB	None
Sopt	Optimum source reflection for NFmin	None	None
Rn	Equivalent noise resistance	None	None
Z1	Reference impedance for port 1 (real or complex number)	None	None
Z2	Reference impedance for port 2 (real or complex number)	None	None
ClipDataFile	Clip data beyond maximum input power: NO to disable; YES to enable	None	NO
ImpNoncausalLength	Non-causal function impulse response order	Integer	None
ImpMode	Convolution mode	Integer	None
ImpMaxFreq	Maximum frequency to which device is evaluated	None	None
ImpDeltaFreq	Sample spacing in frequency	None	None
ImpMaxOrder	Maximum allowed impulse response order	Integer	None
ImpWindow	Smoothing window	Integer	None
ImpRelTol	Relative impulse response truncation factor	None	None
ImpAbsTol	Absolute impulse response truncation factor	None	None

Range of Usage

NF \geq 0 dB
 NFmin > 0

Advanced Design System 2008

$0 < |S_{opt}| < 1$
 $0 < R_n$
 $\text{GainCompFreq} > 0$
 For $S_{21} = \text{mag/ang}$
 $|S_{21}| > 0$

Gain Compression Parameters

Name	Description	Units	Default
GainCompType	Gain compression type:	None	None
GainCompFreq	Reference frequency for gain compression (if gain compression is described as a function of frequency)	None	None
ReferToInput	Specify gain compression with respect to input or output power of device	None	None
SOI	Second order intercept	dBm	None
TOI	Third order intercept	dBm	None
Psat	Power level at saturation	dBm	None
GainCompSat	Gain compression at Psat	dB	None
GainCompPower	Power level in dBm at gain compression for X dB compression point, specified by GainComp	dBm	None
GainComp	Gain compression at GainCompPower	dB	1
AM2PM	Amplitude modulation to phase modulation	deg/dB	None
PAM2PM	Power level at AM2PM	dBm	None
GainCompFile	Filename for gain compression data in S2D file format	None	None

Range of Usage for Gain Compression Parameters

When specifying gain compression using model parameters, only certain combination of parameters will produce stable polynomial curve fitting. The recommended parameter combinations are listed here.

 Note If unrealistic parameter values are used, the polynomial will become unstable, resulting in oscillations.

- Third-order intercept and 1dB gain compression parameters:
TOI, GainCompPower with GainComp=1dB
Range of validity: TOI > GainCompPower + 10.8
- Third-order intercept and power saturation parameters:
TOI, Psat, GainCompSat
Range of validity: TOI > Psat + 8.6
- 1dB gain compression and power saturation parameters:
GainCompPower with GainComp=1dB, Psat, GainCompSat
Range of validity: Psat > GainCompPower + 3
- Third-order intercept, 1dB gain compression and power saturation parameters:
TOI, GainCompPower with GainComp=1dB, Psat, GainCompSat
Range of validity: Psat > GainCompPower + 3, TOI > GainCompPower + 10.8
- Second-order intercept and third-order intercept parameters: SOI, TOI
- AM to PM with 1dB gain compression parameters:
AM2PM, PAM2PM, and GainCompPower with GainComp=1dB
The value for AM2PM must satisfy this condition to avoid a square root of a negative number:

$$AM2PM < \frac{180}{\pi} \times 10^{((PAM2PM - GainCompPower)/10)} \times 10^{(-3 \times (GainComp)/20)}$$

$$\frac{1}{2.34}$$

- AM to PM with third-order intercept parameters:
AM2PM, PAM2PM, and TOI
The value for AM2PM must satisfy this condition to avoid a square root of a negative number:

$$AM2PM < \frac{\left(\frac{180}{\pi}\right) \times 10^{((PAM2PM - TOI)/10)}}{2.34}$$

If SOI is not specified, the amplifier is modeled using a polynomial of odd orders:

$$y = a1 \times x + a3 \times x^3 + a5 \times x^5 + \dots$$

As a result, only odd order harmonics ($m \times f$, where m is an odd number) and odd order intermods ($m \times f1 + n \times f2$, where $m+n$ is an odd number) are taken into account.

If SOI is specified, the amplifier polynomial has an even order term:

$$y = a1 \times x + a2 \times x^2 + a3 \times x^3 + a5 \times x^5 + \dots$$

As a result, both odd and even order harmonics and intermods are taken into account in the simulation.

Warning Messages

When values for TOI, 1 GainCompPower, and Psat are properly related, the DC input-output transfer characteristic has the form shown in [DC Input-Output Transfer Characteristics](#).

- No Saturation. A warning is displayed if a polynomial is generated that does not have a maximum where the transfer characteristics can be clipped (when the amplifier cannot reach saturation). Refer to [No Saturation](#)

[Warning.](#)

- Non-Monotonic Transfer Curve. A warning is displayed if the value specified for Psat is lower than GainCompPower. Refer to [Non-Monotonic Transfer Curve Warning](#).

The result of this specification is that the saturated output is lower than the output at the 1 dB compression point, and the input-output characteristics have a non-monotonic characteristic transfer curve.

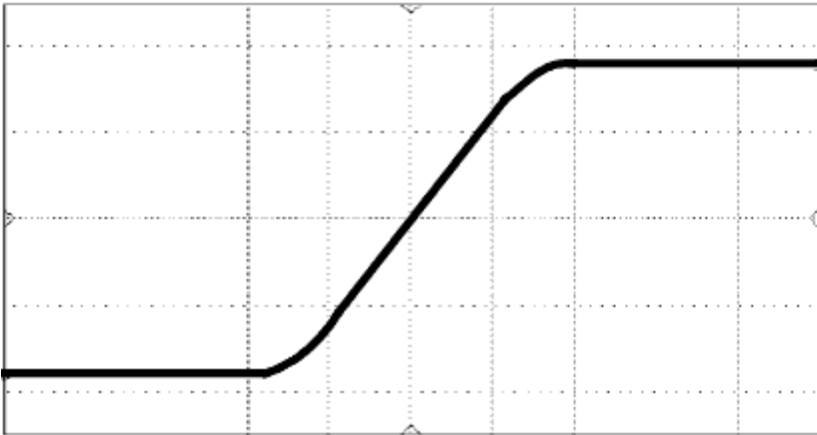

DC Input-Output Transfer Characteristics

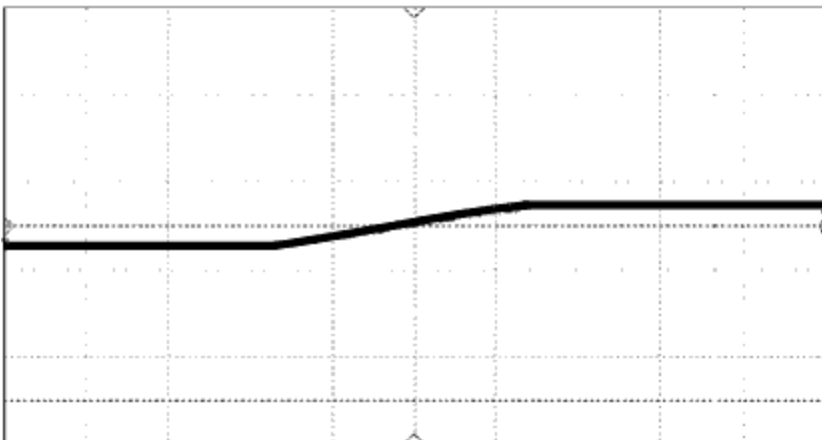

No Saturation Warning

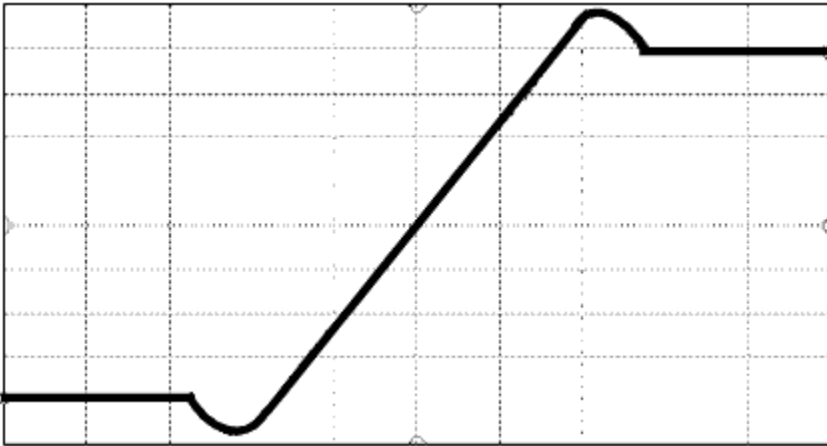

Non-Monotonic Transfer Curve Warning

Notes/Equations

1. If NFmin, Sopt, and Rn are used to characterize noise, the following relation must be satisfied for a realistic model.

$$\frac{Rn}{Z_0} \geq \frac{T_0(F_{min} - 1)|1 + S_{opt}|^2}{T^4} \frac{(1 - |S_{11}|^2)}{|1 - S_{opt} S_{11}|^2}$$

A warning message will be issued if Rn does not meet this criterion. If the noise parameters attempt to describe a system that requires negative noise (due to Rn being too small), the negative part of the noise will be set to zero and a warning message will be issued.

2. Use the function polar(mag,ang), or dbpolar(dB, ang), or VSWRpolar(VSWR, ang) to convert these specifications into a complex number.
3. For an S-parameter or a noise figure sinusoidal ripple, use the function ripple (mag, intercept, period, variable); for example ripple(0.1, 0, 10 MHz, freq).
example: S21=dbpolar(10+ripple(),0.)
4. When you define the gain using S21, keep in mind that this gain is applied to the forward incident wave into the input of the amplifier. This is in keeping with the measurement standards used to define amplifier gain at a system level. This means that if you change S11 from 0 to 0.9 for example, you will see no change in output power because the reflect wave is not taken into account by the amplifier's definition of gain, only the incident wave.
5. Z1 and Z2, the reference impedance parameters for ports 1 and 2, are used in conjunction with the parameters S11/S21/S12/S22. This is because S-data is always used with respect to a particular reference impedance.
6. This model blocks dc.
7. For circuit envelope simulation, baseband signals are blocked.
8. OmniSys used GComp1-GComp7 data items for specifying gain compression. [Gain Compression Data for OmniSys and ADS](#) summarizes the gain compression data for OmniSys and ADS. Refer to [OmniSys Parameter Information](#) for OmniSys parameter information.

Advanced Design System 2008

GComp1-GComp6 can be specified by using the corresponding ADS gain compression parameters and setting GainCompType=LIST. Or, they can also be contained in an S2D format setting GainCompType=FILE. Also note that an S2D file could contain other data such as small signal S-parameters and noise; these data are ignored by the RF System Amplifier.

OmniSys	ADS
GComp1: IP3	TOI
GComp2: 1dBc	GainComp=1dB GainCompPower
GComp3: IP3, 1dBc	TOI GainComp=1dB GainCompPower
GComp4: IP3, Ps, GCS	TOI Psat GainCompSat
GComp5: 1dBc, Ps, GCS	GainComp=1dB GainCompPower Psat GainCompSat
GComp6: IP3, 1dBc, Ps, GCS	TOI GainComp=1dB GainCompPower Psat GainCompSat
GComp7	GainCompType=FILE GainCompFile=filename

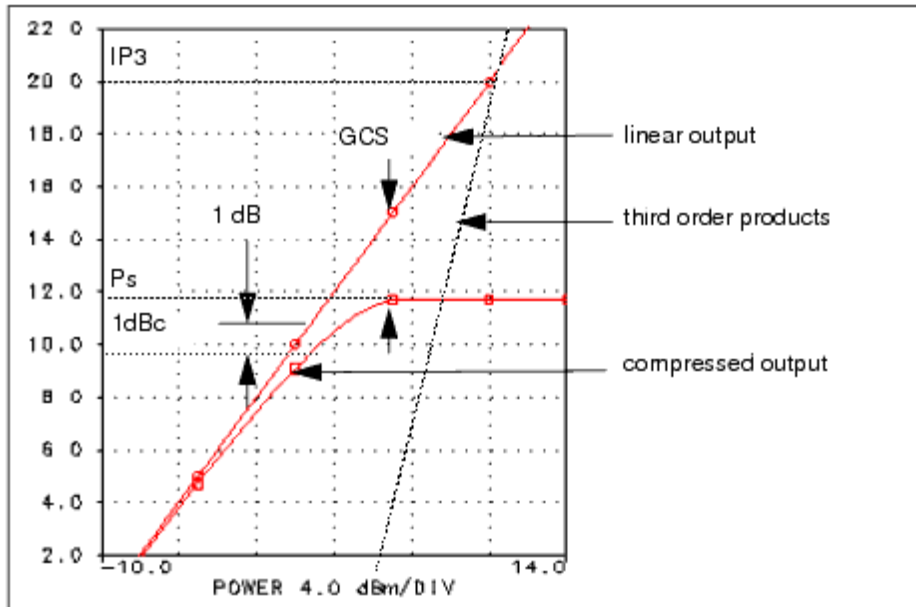

OmniSys Parameter Information

1. The AM to PM option uses parabolic amplitude dependence to describe the amplitude to phase modulation conversion. When a signal of type V in $(\tau)=A\cos(W\phi\tau)$, is applied to the input of a device with parabolic AM to PM, the output phase exhibits:

$$Phase(V_{out}(\tau)) = kA^2$$

Therefore, this phase depends on the input signal amplitude A in a parabolic manner. Because the conversion of amplitude to phase is amplitude dependent, the AM to PM (AM2PM) is specified in degrees per decibel at a given output power (PAM2PM). k is calculated from these two parameters.

$$k = \frac{AM2PM\left(\frac{\pi}{180}\right)2.34}{10^{\left(\frac{PAM2PM-30}{10}\right)}}$$

When AM to PM is specified, the third-order intermod and gain compression are side effects. If AM2PM is specified to be very large compared to the third-order intercept or gain compression, a warning is issued.

Amplifier2 (RF System Amplifier)

Symbol

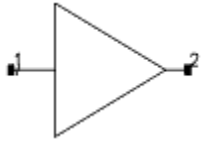

Available in ADS and RFDE

Parameters

Name	Description	Units	Default
S21	Forward transmission coefficient, use $x + j \times y$, $\text{polar}(x,y)$, $\text{dbpolar}(x,y)$ for complex value	None	$\text{dbpolar}(0,0)$
S11	Forward reflection coefficient, use $x + j \times y$, $\text{polar}(x,y)$, $\text{dbpolar}(x,y)$, $\text{vswrpolar}(x,y)$ for complex value	None	$\text{polar}(0,0)$
S22	Reverse Reflection Coefficient, use $x + j \times y$, $\text{polar}(x,y)$, $\text{dbpolar}(x,y)$, $\text{vswrpolar}(x,y)$ for complex value	None	$\text{polar}(0,180)$
S12	Reverse Transmission Coefficient, use $x + j \times y$, $\text{polar}(x,y)$, $\text{dbpolar}(x,y)$ for complex value	None	0
NF	Noise figure [NF mode used for $\text{NFmin}=0$]	dB	None
NFmin	Minimum noise figure at Sopt [(NFmin,Sopt,Rn) mode used for $\text{NFmin}>0$]	dB	None
Sopt	Optimum source reflection for minimum noise figure [(NFmin,Sopt,Rn) mode used for $\text{NFmin}>0$]	None	None
Rn	Equivalent noise resistance [(NFmin,Sopt,Rn) mode used for $\text{NFmin}>0$]	None	

Advanced Design System 2008

Z1	Reference impedance for port 1 (must be a real number)	None	
Z2	Reference impedance for port 2 (must be a real number)	None	
GainCompType	Gain compression type:	None	LIST
GainCompFreq	Frequency at which Gain Compression is specified	None	
ReferToInput	Specify each of the gain compression options outlined in Polynomial Order for Various Magnitude Modes with respect to the input or output power of the device:	None	OUTPUT
SOI	Second order intercept	dBm	None
TOI	Third order intercept	dBm	None
Psat	Power saturation point (always referred to output, regardless of the value of the ReferToInput parameter)	dBm	None
GainCompSat	Gain compression at Psat	dB	5.0
GainCompPower	Power Level at gain compression specified by GainComp	dBm	None
GainComp	Gain Compression at GainCompPower	dB	1.0
AM2PM	Amplitude modulation to phase modulation	deg/dB	None
PAM2PM	Power level at AM2PM	dBm	None
GainCompFile	Filename for gain compression data in S2D file format	None	None
ClipDataFile	Clip data beyond maximum input power: YES=enable, NO=disable	None	yes
ImpNoncausalLength	Non-causal function impulse response order	Integer	None

Advanced Design System 2008

ImpMode	Convolution mode	Integer	None
ImpMaxFreq	Maximum frequency to which device is evaluated	None	
ImpDeltaFreq	Sample spacing in frequency	None	
ImpMaxOrder	Maximum allowed impulse response order	Integer	None
ImpWindow	Smoothing window	Integer	None
ImpRelTol	Relative impulse response truncation factor	None	None
ImpAbsTol	Absolute impulse response truncation factor	None	None

Frequently Asked Questions

Q1 : What are the major differences between Amplifier and Amplifier2?

A1 : Refer to [note 1](#).

Q2 : What are the supported parameter combinations?

A2 : Refer to [Range of Usage](#).

Q3 : What is the range of usage for each parameter combination?

A3 : Refer to [Range of Usage](#).

Q4 : What model is being used?

A4 : A polynomial model. Refer to [Modeling Basics](#).

Q5 : What polynomial order is being used?

A5 : It depends on the parameters set on the component. Refer to [Modeling Basics](#).

Q6 : Can these polynomials blow up?

A6 : No, these polynomials are limited. Refer to [Modeling Basics](#) for details.

Q7 : The parameters specified for Amplifier2 match those for my transistor level amplifier. Why don't the harmonics generated by Amplifier2 match those for my transistor level amplifier?

A7 : Amplifier2 only matches the specified parameters. Refer to [Modeling Basics](#) for details.

Q8 : I have a small-signal and a large-signal tone. Why does the small-signal tone have a smaller gain than the large-signal tone?

A8 : It is a consequence of the polynomial model adopted by Amplifier2. Refer to [Modeling Basics](#) for details.

Advanced Design System 2008

Q9 : In a swept-power harmonic balance simulation, my higher-order harmonics are zero up to a certain order but then they suddenly experience a very sharp increase. Isn't this wrong?

A9 : No, it's called generating a square wave via hard limiting. Refer to [Modeling Basics](#) for details.

Q10 : How do I validate AM to PM conversion?

A10 : Refer to [AM to PM Conversion](#).

Q11 : Why does AM to PM conversion only match my transistor level amplifier around the power level PAM2PM at which I specified AM2PM?

A11 : With information at only one power level, Amplifier2 has to rely on assumptions and generic curve shapes to model AM to PM at all power levels. For better modeling, use an S2D file and specify the exact magnitude and phase variation of your amplifier. Refer to [AM to PM Conversion](#) for details.

Q12 : With AM to PM conversion enabled, my output phase is supposed to be constant at high power levels. Why does my AM to PM start changing at high power levels?

A12 : This is probably due to harmonic balance aliasing errors and can be mitigated by oversampling. Refer to [AM to PM Conversion](#) for details.

Q13 : With AM to PM conversion enabled, why don't the predicted second- and third-order intercept points match SOI and TOI as set on Amplifier2?

A13 : It is a consequence of fitting the magnitude and phase separately. Refer to [AM to PM Conversion](#) for details.

Q14 : Why do Amplifier2's noise results differ from those for Amplifier?

A14 : Amplifier2 models noise differently from Amplifier. Refer to [Noise](#) for details.

Q15 : What noise model is used by Amplifier2?

A15 : Refer to [Noise](#).

Q16 : What is "NF-only mode" and "(NFmin,Sopt,Rn) mode" for Amplifier2?

A16 : It is two different ways of specifying noise. Refer to [Noise](#) for details.

Q17 : How is NFssb/NFdsb calculated, both at low powers and in compression?

A17 : Refer to [Noise](#).

Q18 : Can you provide more details about the noise voltages and noise figures produced by Amplifier2 for the different modes of operation?

A18 : Refer to [Noise](#) .

Q19 : With complex S21, why does Amplifier2 differ from Amplifier?

A19 : Amplifier2 handles complex S21 values differently from Amplifier, leading to more physical waveforms. Refer to [note 5](#) for details.

Q20 : Why doesn't Amplifier2 work for complex reference impedances?

Advanced Design System 2008

A20 : Amplifier2 does not support complex reference impedances, per [note 7](#).

Q21 : Why is Amplifier2 sometimes slower than Amplifier?

A21 : This is a consequence of the implementational differences between Amplifier and Amplifier2. Refer to [note 10](#) for details.

Q22 : Why don't the predicted second- and third-order intercept points match SOI and TOI as set on Amplifier2?

A22 : You are probably not setting up your validation correctly. Make sure to do a two-tone simulation, not a one-tone simulation. Refer to [note 11](#) for details.

Q23 : Why does my ACPR level get better as I get deeper into compression?

A23 : This is a consequence of the polynomial model adopted by Amplifier2. Refer to [note 12](#) for details.

Q24 : Why does Amplifier2 ignore the ACDATA block of my S2D file?

A24 : It uses the S-parameters on the component instead. Refer to [note 13](#) for details.

Q25 : When the power range in an S2D file differs from that of a simulation, which power range is used for polynomial fitting?

A25 : The power range in the S2D file. Refer to [note 15](#) for details.

Q26 : Why do I get ringing at high powers when using an S2D file?

A26 : This is a consequence of the polynomial model adopted by Amplifier2. Refer to [note 16](#) for details.

Q27 : How do I get rid of this ringing?

A27 : Eliminate data for high input powers, rely on extrapolation via ClipDataFile=yes, or break the S2D file into two. Worst case, use AmpSingleCarrier. Refer to [note 16](#) for details.

Q28 : Why do I see different results when I use the Analog/RF Amplifier2 component and the Ptolemy GainRF component with the same parameters?

A28 : While based on the same OmniSys legacy, the implementations differ and thus the components can give different results. Refer to [note 18](#) for details.

Range of Usage

$|S_{ij}| > 0$ ($i=1,2; j=1,2$)

$NF \geq 0$ dB

$NF_{min} \geq 0$ dB

$0 < |S_{opt}| < 1$

$R_n > 0$

$GainCompFreq > 0$

$0 \text{ dB} < GainComp < 3 \text{ dB}$

When specifying gain compression using model parameters, only certain combinations of parameters will produce

stable polynomial curve fitting. If unrealistic parameter values are used, the polynomial will become unstable, resulting in oscillations. The recommended parameter combinations are listed here:

- Third-order intercept parameter:
Parameters: TOI
Range of validity: N/A
- Gain compression parameters:
Parameters: GainCompPower, GainComp
Range of validity: N/A
- Power saturation parameters:
Parameters: Psat, GainCompSat
Range of validity: N/A
- Third-order intercept and 1dB gain compression parameters:
Parameters: TOI, GainCompPower with GainComp=1dB
Range of validity: TOI > GainCompPower + 10.8
- Third-order intercept and power saturation parameters:
Parameters: TOI, Psat, GainCompSat
Range of validity: TOI > Psat + 8.6
- 1dB gain compression and power saturation parameters:
Parameters: GainCompPower with GainComp=1dB, Psat, GainCompSat
Range of validity: Psat > GainCompPower + 3
- Third-order intercept, 1dB gain compression and power saturation parameters:
Parameters: TOI, GainCompPower with GainComp=1dB, Psat, GainCompSat
Range of validity: Psat > GainCompPower + 3, TOI > GainCompPower + 10.8
- Second-order intercept and third-order intercept parameters:
Parameters: SOI, TOI
Range of validity: N/A

Modeling Basics

Amplifier2 is based on a polynomial model of the magnitude of the output voltage as a function of the input voltage. If SOI is not specified, the magnitude response is modeled using a polynomial of odd orders

$$y = a_1 \times x + a_3 \times x^3 + a_5 \times x^5 + \dots$$

The order of the polynomial depends on the data entered by the user. If SOI is specified, the magnitude response has an even order term

$$y = a_1 \times x + a_2 \times x^2 + a_3 \times x^3$$

The order of the polynomial is hardwired at 3. The polynomial orders for the various magnitude modes are summarized in [Polynomial Order for Various Magnitude Modes](#).

Magnitude Mode	Polynomial Order
TOI	3
SOI, TOI	3 (with second-order term)
GainCompPower, GainComp	3
Psat, GainCompSat	5

TOI, GainComp=1dB, GainCompPower	5
TOI, Psat, GainCompSat	7
GainComp=1dB, GainCompPower, Psat, GainCompSat	7
TOI, GainComp=1dB, GainCompPower, Psat, GainCompSat	9

For GainCompType=LIST, the phase response is described in the section [AM to PM Conversion](#). For GainCompType=FILE and a GCOMP1-GCOMP6 block in the S2D file, the phase response is zero. For GainCompType=FILE and a GCOMP7 block in the S2D file, the phase response is modeled using an odd order polynomial, just like the magnitude response.

To prevent these polynomial expressions from blowing up and resulting in a non-physical model, the polynomial model is only used up to the largest x fulfilling $dy / dx = 0$, denoted by x_0 . Above this value, the amplifier is hard-limited at $y(x_0)$.

The polynomial coefficients for Amplifier2 are based on the parameters set for Amplifier2 regardless of the context in which Amplifier2 is used and the actual number of tones at the input of Amplifier2. These polynomial coefficients are then applied when Amplifier2 is analyzed in the environment where it lives. For example, given GainComp and GainCompPower, the polynomial coefficients are determined by exciting Amplifier2 with a one-tone signal and requiring the compressed output power to be GainComp below the linear response at GainCompPower. This can be confirmed by doing a one-tone analysis of Amplifier2. These polynomial coefficients are then used in any analysis using Amplifier2, whether it be a one-tone or a multi-tone analysis.

Amplifier2 matches the parameters that have been set on the component but is not guaranteed to match any other characteristics of a transistor level amplifier. Assume three parameters have been specified for Amplifier2: the linear gain S_{21} , the 1 dB compression point GainCompPower (GainComp is set to 1 dB), and the third-order intercept TOI. This means that the behavior of Amplifier2 must match these parameters and nothing else. This is achieved by modeling y as a function of x via $y = a_1 \times x + a_3 \times x^3 + a_5 \times x^5$. The three known quantities allow the determination of the three unknown polynomial coefficients. If we look at this equation, we see that there is a fifth-order term. Therefore, Amplifier2 will produce fifth-order harmonics. However, this fifth-order order term is not supposed to match that from the transistor level amplifier from which the three parameters S_{21} , GainCompPower and TOI were extracted. No information about the fifth-order intercept of that amplifier has been specified so we cannot match it. The fifth-order term for Amplifier2 is necessary to properly model S_{21} , GainCompPower and TOI and these parameters are properly modeled. In general, a transistor level amplifier will produce finite higher order harmonics which Amplifier2 does not produce.

For GainCompType=FILE and a GCOMP7 block in the S2D file, the magnitude and phase data in the GCOMP7 block of the S2D file is fitted to two separate polynomials. With n power points in the GCOMP7 block, the polynomial order will be $\min(2 \times n - 1, 9)$. In most practical cases, the GCOMP7 block will have data at five or more power points and consequently ninth-order polynomials with odd-only terms will be used.

Consider now an amplifier with the response

$$y = a_1 \times x + a_2 \times x^2 + a_3 \times x^3$$

This is the model used when S_{21} , SOI and TOI are specified. If a_2 and a_3 are non-zero, they will be negative. When $a_2=0$, this is the model used when S_{21} and TOI are specified. When $a_2 = a_3=0$, this represents a linear amplifier. The behavior of this amplifier can be analyzed analytically when the excitation is simple enough. Doing so gives a

good understanding of the behavior of more complicated amplifiers with different excitations.

Assuming the excitation

$$x(t) = A1 \times \cos(\omega1 \times t)$$

we get the response

$$y(t) = \frac{1}{2} \times a2 \times A1^2$$

$$+ \left(a1 \times A1 + \frac{3}{4} \times a3 \times A1^3 \right) \times \cos(\omega1 \times t)$$

$$+ \frac{1}{2} \times a2 \times A1^2 \times \cos(2 \times \omega1 \times t)$$

$$+ \frac{1}{4} \times a3 \times A1^3 \times \cos(3 \times \omega1 \times t)$$

and can define the gain of the fundamental $A1 \times \cos(\omega1 \times t)$ as

$$G1 = a1 + \frac{3}{4} \times a3 \times A1^2$$

Assuming the excitation

$$x(t) = A1 \times \cos(\omega1 \times t) + A2 \times \cos(\omega2 \times t)$$

we get the response

$$y(t) = \frac{1}{2} \times a2 \times (A1^2 + A2^2)$$

$$+ \left(a1 \times A1 + \frac{3}{4} \times a3 \times A1^3 + \frac{3}{2} \times a3 \times A1 \times A2^2 \right) \times \cos(\omega1 \times t)$$

$$+ \left(a1 \times A2 + \frac{3}{4} \times a3 \times A2^3 + \frac{3}{2} \times a3 \times A2 \times A1^2 \right) \times \cos(\omega2 \times t)$$

$$+ \frac{1}{2} \times a2 \times A1^2 \times \cos(2 \times \omega1 \times t)$$

$$+ \frac{1}{2} \times a2 \times A2^2 \times \cos(2 \times \omega2 \times t)$$

$$\begin{aligned}
 & + \frac{1}{4} \times a_3 \times A_1^3 \times \cos(3 \times \omega_1 \times t) \\
 & + \frac{1}{4} \times a_3 \times A_2^3 \times \cos(3 \times \omega_2 \times t) \\
 & + a_2 \times A_1 \times A_2 \times \cos((\omega_1 - \omega_2) \times t) \\
 & + a_2 \times A_1 \times A_2 \times \cos((\omega_1 + \omega_2) \times t) \\
 & + \frac{3}{4} \times a_3 \times A_2 \times A_1^2 \times \cos((2 \times \omega_1 + \omega_2) \times t) \\
 & + \frac{3}{4} \times a_3 \times A_2 \times A_1^2 \times \cos((2 \times \omega_1 - \omega_2) \times t) \\
 & + \frac{3}{4} \times a_3 \times A_1 \times A_2^2 \times \cos((2 \times \omega_2 + \omega_1) \times t) \\
 & + \frac{3}{4} \times a_3 \times A_1 \times A_2^2 \times \cos((2 \times \omega_2 - \omega_1) \times t)
 \end{aligned}$$

and can define the gain of the fundamentals $A_1 \times \cos(\omega_1 \times t)$ and $A_2 \times \cos(\omega_2 \times t)$ as

$$G_1 = a_1 + a_3 \times \left(\frac{3}{4} \times A_1^2 + \frac{3}{2} \times A_2^2 \right)$$

and

$$G_2 = a_1 + a_3 \times \left(\frac{3}{2} \times A_1^2 + \frac{3}{4} \times A_2^2 \right)$$

respectively.

Examining G_1 and G_2 closer, we see that $G_1 > G_2$ for $A_1 > A_2$ and $a_3 < 0$. This means that if we excite a polynomial amplifier with a large- and a small-signal tone, the large-signal tone will experience a larger gain than the small-signal tone. For more details, please refer to "Polynomial Model of Blocker Effects on LNA/Mixer Devices" by W. Domino et. al. in the June 2001 issue of Applied Microwave and Wireless.

This behavior is counter-intuitive for some people. If we excite an amplifier with a small-signal tone, it will provide its maximum/linear gain. If we excite the same amplifier with a large-signal tone, it will provide a smaller/compressed gain. If we excite an amplifier with both a large- and a small-signal tone, one could then expect that the small-signal tone would be subject to a larger gain than the large-signal tone. The above shows that this is not how Amplifier2

behaves.

This behavior, however, is intuitive for some people. If we consider an ideal hard limiting amplifier with an input voltage of V_{in} and an output voltage of V_{max} , it has a large-signal gain of V_{max}/V_{in} but a small-signal gain of zero, suggesting a larger large-signal gain than small-signal gain. This is in line with how Amplifier2 behaves.

Above, we presented the polynomial model used for modeling the output voltage as a function of the input voltage. This polynomial model, however, does not fully describe the response of the amplifier. It is important to remember that the amplifier has a power level at which it saturates and above which the output is clipped. We also presented the result of pushing $A_1 \times \cos(\omega_1 \times t)$ and $A_1 \times \cos(\omega_1 \times t) + A_2 \times \cos(\omega_2 \times t)$ signals through a $y = a_1 \times x + a_2 \times x^2 + a_3 \times x^3$ nonlinearity. The result is an output voltage consisting of a finite number of $C_n \times \cos(n \times \omega_n \times t)$ terms. More generally, it can easily be shown that pushing a sum of $A_i \times \cos(\omega_i \times t)$ terms through a polynomial nonlinearity will result in a finite number of $C_n \times \cos(n \times \omega_n \times t)$ terms. It might then be expected that a harmonic balance analysis of such an amplifier can only produce finite harmonics up to a certain order but will always produce zero harmonics beyond a certain order. This is the case when the amplifier is not hard limiting but is not the case when the amplifier starts hard limiting.

When we analyze an amplifier via a harmonic balance simulation of a certain order, the harmonics we will see on the input and output of the amplifier will be those which lead to the most correct input and output waveforms that can be achieved with the given order.

Assume the input waveform is a sine wave. This can be represented exactly using only the fundamental. Therefore, we will see a finite fundamental tone and zero harmonics on the input.

The output waveform depends on the input power level.

At low input powers, the output waveform is simply a sine wave, namely the input sine wave scaled by the linear amplifier gain. This can be represented exactly using only the fundamental. Therefore, we will see a finite fundamental tone and zero harmonics.

At higher input powers where the amplifier enters compression, the output waveform is the input sine wave pushed through the amplifier polynomial. Because a sine wave pushed through a polynomial gives rise to sine terms and no others, the output waveform will have finite harmonics up to a certain order and zero harmonics above that order.

At high enough input powers that the amplifier starts hard limiting, the output waveform is a clipped sine wave. For increasingly high input powers, this clipped sine wave approaches a square wave. Representation of such a clipped wave requires finite third, fifth, seventh, etc. harmonics so when the amplifier starts clipping all harmonics will be finite. This means that we will see a very sharp increase in the level of all such harmonics as soon as the amplifier starts clipping. If we increase the input power enough, we get approximately a square wave output. When this happens, the levels of the various harmonics reach saturation. The relative values of these saturated power levels can be predicted from the Fourier representation of a square wave.

The Amplifier component supports AM to PM conversion for a very limited number of magnitude modes; Amplifier2 supports AM to PM conversion for all magnitude modes when GainCompType=LIST. Magnitude and phase is fitted separately so AM to PM conversion can be added for each magnitude mode. This adds a phase response but does not alter the magnitude response.

AM to PM conversion is defined as the amount of phase change in degrees per magnitude/power change in dB. It is specified via the two parameters AM2PM and PAM2PM. AM2PM [degrees/dB] is the amount of AM to PM conversion while PAM2PM [dBm] is the power level at which the amplifier has this amount of AM to PM conversion. A physically sensible phase response is then constructed which has a phase of phase(S21) at low powers, an amount of AM to PM conversion given by AM2PM at PAM2PM, constant phase at high powers and for which the maximum amount of AM to PM at any power level is also given by AM2PM. Stated differently, the derivative of the phase response with respect to power in dB takes its maximum value AM2PM at PAM2PM.

This phase response is far from unique and certainly will not be correct for all amplifiers. Based only on the amount of AM to PM at one power level, there is simply no way to construct a phase response that matches any circuit level amplifier at all power levels. This AM to PM capability is only meant as a crude way of incorporating a phase response for amplifiers about which very little information is known - at the initial system level design iterations, For example, where no transistor level amplifier has been designed. Once more information about the amplifier's phase response is known and a more accurate phase modeling is desired, use Amplifier2 with GainCompType=FILE and specify the (compression and) phase response as a function of power in the GCOMP7 block of an S2D file. This is much more accurate than what this AM to PM capability can provide.

To document the exact phase response in a little more detail, we start out with AM2PM [degrees/dB] and PAM2PM [dBm]. We first define:

$$k = \text{AM2PM}$$

$$P = 10 (\text{PAM2PM} - 30) / 10$$

For a sine wave

$$A_0 \times \cos(\omega \times t)$$

the average power is

$$P = \int_{\text{period}} (A_0 \times \cos(\omega \times t))^2 dt = \frac{A_0^2}{2}$$

Therefore, we have

$$A_0 = \sqrt{2 \times P}$$

The phase response is initially modeled in the A-domain. We choose

$$y(A) = c_0 + c_1 \times A + c_2 \times A^2 + c_3 \times A^3$$

We now get

$$y(0) = 0 \rightarrow c_0 = 0$$

$$dy / dA (0) = 0 \rightarrow c_1 = 0$$

$$dy / dA (A_0) = k \rightarrow 2 \times A_0 \times c_2 + 3 \times A_0^2 \times c_3 = 0$$

$$d^2 y / dA^2 (A_0) = 0 \rightarrow c_2 + 3 \times A_0 \times c_3 = 0$$

$$c_2 = k / A_0$$

$$c_3 = -k / (3 \times A_0^2)$$

Then, we have

$$y(A) = k / A_0 \times A^2 - k / (3 \times A_0^2) \times A^3$$

This function has the following properties

$$y(0) = 0$$

$$\begin{aligned}
 dy / dA (A_0) &= 0 \\
 y (A_0) &= \frac{2}{3} \times k \times A_0^3 \\
 dy / dA (A_0) &= k \times 2 \times A_0^2 \\
 d^2 y / dA^2 (A_0) &= 0 \quad (A_0 \text{ is an extremum, max AM to PM occurs here}) \\
 y (2 \times A_0) &= \frac{4}{3} \times k \times A_0^3 = 2 \times y (A_0) \\
 dy / dA (2 \times A_0) &= 0
 \end{aligned}$$

This curve will be distorted when it is made a function of power in dBm instead of magnitude A. The difference between two log values can be quite significant at small values but will be much smaller at large values. This means that the log function will distort the curve - it will be stretched out at low powers and will be compressed at high powers. This will change the point where the maximum slope occurs so the curve is shifted/scaled such that the maximum slope AM2PM occurs at PAM2PM. Also, we account for the fact that the derivative with respect to A must be in dB and not linear numbers.

The above phase response applies to the fundamental tone. This phase shift is applied before the application of the nonlinear polynomial which means that the change of the phase response of the nth order harmonic from its low power value will equal that for the fundamental tone scaled by the harmonic index n.

The easiest way to validate that the amount of AM to PM conversion takes its maximum value AM2PM at PAM2PM is to use the diff function in ADS. If the Amplifier2 output voltage is denoted by Vout and determined via a swept input power harmonic balance simulation, simply plot diff(phase(Vout[:,1])). The peak of this curve should occur at PAM2PM and should take the value AM2PM.

All harmonic balance simulations can be subject to aliasing errors. This can significantly change the phase response of an amplifier. To mitigate the effects of harmonic balance aliasing errors, increase the Fundamental Oversample (FundOversample) parameter on the HarmonicBalance controller from the default 1 to, say, 16.

The magnitude and phase response for Amplifier2 are fitted separately. Given, say, SOI and TOI, a set of magnitude polynomial coefficients are determined such that Amplifier2 has a second-order intercept point of SOI and a third-order intercept point of TOI. Given AM2PM and PAM2PM, a set of phase polynomial coefficients are determined such that Amplifier2 has AM to PM conversion given by AM2PM at PAM2PM. When using an Amplifier2 with both a magnitude and a phase response in a multi-tone harmonic balance simulation, there is no guarantee that the above magnitude and phase separation will hold. Generally, a phase response will generate intermodulation distortion with a multi-tone input. This is part of why AM to PM conversion is of interest. This means that the third-order intercept point may no longer be the TOI set on the component. Amplifier2 makes no attempt at matching the composite magnitude/phase third-order intercept point to the TOI set on the component but simply uses the polynomial coefficients derived for the isolated magnitude mode.

Noise

Given the minimum noise figure NF_{min} (real), the optimal reflection coefficient S_{opt} (complex), the noise resistance R_n (real), the noise reference impedance R_{ref} (real), and the source admittance Y_s (complex), the noise figure NF of an amplifier is determined by:

$$Y_{opt} = \frac{1}{R_{ref}} \times \frac{1 - S_{opt}}{1 + S_{opt}}$$

$$F_{min} = 10^{NF_{min}/10}$$

$$F = F_{min} + \frac{R_n}{\text{Real}[Y_s]} \times |Y_s - Y_{opt}|^2$$

$$NF = 10 \times \log(F)$$

Note that this is independent of the amplifier S-parameters.

The noise behavior of Amplifier2 is characterized by the four noise parameters NF, NFmin, Sopt and Rn and the reference impedance Z1 for port 1. Amplifier2 is implemented as a Noisy2Port cascaded with an SDD. The above-mentioned five parameters control the parameters for the Noisy2Port, the Noisy2Port generates a noise voltage on its output and this noise voltage is passed through the SDD in the same manner as the signal.

NF-only mode is used for NFmin=0. This is a special case where only one noise parameter must be specified. In this case, the Noisy2Port has the parameters NFmin=NF, Sopt=0, and Rn=Z1/4 × (10 NF/10 -1). The reference impedance for the noise calculation (not available on the Noisy2Port user interface) is Z1. The NFmin=0, Sopt and Rn parameters are ignored.

(NFmin, Sopt, Rn) mode is used for NFmin>0. This is a more general case than NF-only mode. In this case, the Noisy2Port has the parameters NFmin=NFmin, Sopt=Sopt, and Rn=Rn. The reference impedance for the noise calculation (not available on the Noisy2Port user interface) is Z1. The NF parameter is ignored.

Given an output noise voltage v_n , the single sideband noise figure NFssb and the double sideband noise figure NFdsb are given by:

$$NF_{ssb} = 10 \times \log \left(\frac{(v_n^2 / R + k \times T_0 \times (G_1 + G_2 + \dots))}{(k \times T_0 \times G_1)} \right)$$

$$NF_{dsb} = 10 \times \log \left(\frac{(v_n^2 / R + k \times T_0 \times (G_1 + G_2 + \dots))}{(k \times T_0 \times (G_1 + G_2 + \dots))} \right)$$

where R is the output resistance, $k = 1.380658 \times 10^{-23}$ J/K is Boltzmann's constant, $T_0 = 290$ K is the standard noise temperature, G_1 is the primary power gain from the input noise frequency to the output noise frequency, and $G_2 + \dots$ is the sum of all higher order mixing gains which mix from some input frequency to the output noise frequency. For an amplifier, $G_2 + \dots$ is zero under small-signal operation. v_n^2 / R represents the noise added by the amplifier while $k \times T_0$ represents the noise power available from the input termination. In the following, we outline how Amplifier2 calculates noise voltages and noise figures in various cases. This will be compared to the behavior of Amplifier.

Small-Signal Operation, NF-Only Mode

Consider an amplifier with NF=5 dB, Z1=25 Ohm and S21=1. The corresponding values of NFmin, Sopt and Rn have been described previously. We will consider the two S11 values S11=0 and S11=0.2. The amplifier lives in an environment where $Y_s = 1/50$ Siemens and R=50 Ohm. For this amplifier, the noise figure on the output should be

NF=5.356 dB.

Amplifier calculates the noise voltage via:

$$F_{min} = 10^{NF_{min}/10}$$

$$an^2 = k \times T0 \times (F_{min} - 1)$$

$$bn^2 = S21^2 \times an^2$$

$$vn = \sqrt{R \times bn^2}$$

Doing the numerical evaluations, we get $vn = 657.93\text{pV}$. This value is independent of S11. Because the G 1 term used in the calculation of NFssb and NFdsb varies with S11, NFssb and NFdsb will vary with S11. Specifically, we get NFssb=NFdsb=5.356 dB for S11=0 (matches NF) and NFssb=NFdsb=4.940 dB for S11=0.2 (does not match NF).

Amplifier2 calculates the noise voltage differently. First, four noise correlation coefficients are calculated via:

$$\langle vn, vn \rangle = 4 \times k \times T0 \times Rn$$

$$\langle in, in \rangle = 4 \times k \times T0 \times Rn \times |Yopt|^2$$

$$\langle vn, in \rangle = 4 \times k \times T0 \times Rn \times ((F_{min} - 1)/(2 \times Rn) \times Yopt)$$

$$\langle in, vn \rangle = \text{conj}(\langle vn, in \rangle)$$

The noise voltage can then be calculated from:

$$vn = \sqrt{G \times \langle vn, vn \rangle \times G + G \times \langle vn, in \rangle \times Z + Z \times \langle in, vn \rangle \times G + Z \times \langle in, in \rangle \times Z}$$

where G is the trans-voltage-gain of the amplifier and Z is the trans-impedance of the amplifier. These can be found from an adjoint circuit analysis of the amplifier and become $G = -0.4714$ and $Z = -23.5702$ Ohm for S11=0 and $G = -0.5051$ and $Z = -25.2538$ Ohm for S11=0.2. The noise voltage then becomes $vn = 657.93$ pV for S11=0 and $vn = 704.93$ pV for S11=0.2. We see that vn varies with S11; this is not surprising. The noise voltage at the output of the Noisy2Port is independent of S11 but this voltage is passed through the SDD and will see a small-signal gain. NFssb and NFdsb become 5.356 dB independent of S11 (matches NF).

Small-Signal Operation, (NFmin, Sopt, Rn) Mode

Consider an amplifier with NFmin=5 dB, Sopt=0.1+j × 0.2, Rn=40, Z1=25 Ohm and S21=1. We will consider the two S11 values S11=0 and S11=0.2. The amplifier lives in an environment where Ys=1/(10-j × 20) Siemens and Zl=30. For this amplifier, the noise figure on the output should be NF=9.520 dB.

In this case, Amplifier2 calculates its noise voltage from the same equations as for NF-only mode. The only difference is the NFmin, Sopt and Rn values used. Amplifier2 produces the noise voltage $vn = 766.79$ pV for S11=0 and $vn = 749.68$ pV for S11=0.2. For both S11 values, this leads to NFssb=NFdsb=9.520 dB. Amplifier calculates noise voltages different from NF-only mode but is again wrong. Amplifier produces the noise voltage $vn = 611.47$ pV for S11=0 and $vn = 597.83$ pV for S11=0.2. For both S11 values, this leads to NFssb=NFdsb=7.823 dB.

Large-Signal Operation

The above sections present the noise behavior of Amplifier and Amplifier2 in NF-only mode and (NFmin, Sopt, Rn) mode. These apply as the amplifier is operated under small-signal conditions. As the power is increased and the amplifier is operated under large-signal conditions, the expressions for NFssb and NFdsb still apply but some of the terms change.

Consider the expressions for NFssb and NFdsb. These are:

$$NF_{ssb} = 10 \cdot \log \left(\frac{v_n^2 / R + k \times T_0 \times (G_1 + G_2 + \dots)}{k \times T_0 \times G_1} \right)$$

$$NF_{dsb} = 10 \cdot \log \left(\frac{v_n^2 / R + k \times T_0 \times (G_1 + G_2 + \dots)}{k \times T_0 \times (G_1 + G_2 + \dots)} \right)$$

At low powers, G_1 is the amplifier's small-signal gain and $G_2 + \dots$ is zero. As the power increases and the amplifier compresses, G_1 decreases (gain expansion could precede this trend) and $G_2 + \dots$ increases. This is a function of the signal properties of the amplifier and is independent of the amplifier's noise model. The variation of G_1 and $G_2 + \dots$ as a function of the power level is the same for Amplifier and Amplifier2. This is not the case for the noise voltage v_n . For Amplifier, v_n is constant as the amplifier compresses. For Amplifier2, the noise voltage at the output of the Noisy2Port will pass through the SDD which means that v_n decreases as the amplifier compresses. This lowers v_n^2 / R for Amplifier2 relative to Amplifier, causing Amplifier2 to produce smaller noise figures in compression than Amplifier.

Notes/Equations

1. Amplifier2 is introduced as a replacement for Amplifier. To change an existing Amplifier component to an Amplifier2 component, simply change the name from Amplifier to Amplifier2 on the schematic. The parameters for the two models are the same and Amplifier2 will adopt the values for Amplifier, making parameter re-entry unnecessary. The only exception is that the parameters GainCompType, ReferToInput and ClipDataFile will take their default values LIST, OUTPUT and yes, respectively, regardless of the values these parameters had for Amplifier. Also, the Amplifier display settings will be ignored. Amplifier2 will simply adopt its default settings, displaying S21, S11, S22 and S12.

For examples of how to use Amplifier2, see the example project examples/Tutorial/Amplifier2_Example_prj or search the ADS examples for designs where Amplifier2 is currently used. To locate such examples, use the ADS documentation Search feature, search in: Examples, and enter Amplifier2. As each found item is highlighted, the ADS examples project directory information is displayed; from the ADS Main window select File > Example Project to navigate to these examples.

[Major Differences between Amplifier and Amplifier2](#) summarizes the major differences between Amplifier and Amplifier2.

{anchor:1137295}Major Differences between Amplifier and Amplifier2

Amplifier	Amplifier2
AM to PM only supported for some magnitude modes	AM to PM supported for all magnitude modes
AM to PM broken	AM to PM working
Non-physical noise behavior	Physical noise behavior

Real/imaginary polynomial fit	Magnitude/phase polynomial fit
Complex S21 leads to non-physical time-domain waveforms	Complex S21 leads to physical time-domain waveforms
For large harmonic balance and circuit envelope simulations Amplifier2 may be slower than Amplifier.	

2. Use the functions polar(mag,ang), dbpolar(dB, ang), or VSWRpolar(VSWR, ang) to convert the Sij specifications into complex numbers. Note that Sij are voltage gains and not power gains. For example, an amplifier with S21=polar(10,0) and S11=S22=S12=0 will scale the voltage by a factor of 10 from input to output and will therefore result in a 20 dB increase in power. S21=dbpolar(10,0), on the other hand, will result in a 10 dB increase in power.
3. For an S-parameter or a noise figure sinusoidal ripple, use the function ripple (mag, intercept, frequency, variable); for example ripple(0.1, 0, 10 MHz, freq).
example: S21=dbpolar(10.0+ripple(0.1,0,10MHz,freq),0.0)
4. When defining gain using S21, remember that this gain is applied to the forward incident wave into the input of the amplifier. This is in keeping with the measurement standards used to define amplifier gain at the system level. This means that if we change S11 from 0 to 0.9 for example, we will see no change in output power because the reflected wave is not taken into account by the amplifier's definition of gain, only the incident wave.
5. Amplifier2 behaves differently from Amplifier for complex S21 values. The phase shift is applied before the nonlinear polynomial instead of after, leading to much more realistic waveforms. To see this, consider for example an Amplifier and Amplifier2 with S21=dbpolar(10,50), TOI=20 dBm, GainCompPower=10 dBm and GainComp=2 dB. Excite and terminate these with default P_1Tone and Term components and carry out a high-order harmonic balance analysis, say Order=150, at a high input power, say 30 dBm. Because the amplifiers are excited with a sine wave and operate deep into compression, we expect the output time domain waveform to be clipped and closely resemble a square wave. Except for the expected differences at transitions where the effect of a finite Order is evident, this is the case for Amplifier2 but is not at all the case for Amplifier.
6. Z1 and Z2, the reference impedance parameters for ports 1 and 2, are used in conjunction with the parameters S11/S21/S12/S22. This is because S-data is always used with respect to a particular reference impedance.
7. Amplifier2 does not support complex reference impedances.
8. Amplifier2 passes dc.
9. For circuit envelope simulation, baseband signals are blocked.
10. Amplifier2 may be slower than Amplifier for large harmonic balance and circuit envelope simulations.
11. [Modeling Basics](#) presented the polynomial model used for modeling the output voltage as a function of the input voltage. It also presented the result of pushing an $A_1 \times \cos(\omega_1 \times t) + A_2 \times \cos(\omega_2 \times t)$ signal through a $y = a_1 \times x + a_2 \times x^2 + a_3 \times x^3$ nonlinearity. Based on this, we can calculate the IP2 (second-order intercept) and IP3 (third-order intercept) of the amplifier. The general equation for the nth-order intercept point IP_n is $IP_n = (n \times P_1 - P_n) / (n - 1)$ where P₁ is the power level of the first-order tone and P_n is the power level of the nth-order tone.

The P_n power level, however, is not unique. Look at the amplifier output. Ignoring A₁ and A₂ which we can normalize out, the second-order harmonics $\cos(2 \times \omega_1 \times t)$ and $\cos(2 \times \omega_2 \times t)$ have the amplitude $1/2 \times a_2$ while the second-order intermods $\cos((\omega_1 - \omega_2) \times t)$ and $\cos((\omega_1 + \omega_2) \times t)$ have the amplitude a₂. Similarly, the third-order harmonics $\cos(3 \times \omega_1 \times t)$ and $\cos(3 \times \omega_2 \times t)$ have the amplitude $1/4 \times a_3$ while the third-order intermods $\cos((2 \times \omega_1 + \omega_2) \times t)$, $\cos((2 \times \omega_1 - \omega_2) \times t)$, $\cos((2 \times \omega_2 + \omega_1) \times t)$ and $\cos((2 \times \omega_2 - \omega_1) \times t)$ have the amplitude $3/4 \times a_3$. If the formula $IP_n = (n \times P_1 - P_n) / (n - 1)$ works for one type of second and third-order tone, it will not work for the other.

The industry standard definitions of IP2 and IP3 are based on intermods, not harmonics. When polynomial coefficients are determined in the Amplifier2 code, they are therefore based on intermods. When validating Amplifier2 using intermods, everything checks out; when using harmonics, it does not. This shows that we cannot validate the proper SOI and TOI for Amplifier2 using a one-tone analysis because this generates only

harmonics but not intermods. We use industry standard definitions when deriving the coefficients for Amplifier2 and it is imperative to do the same when validating Amplifier2.

Note that SOI and TOI are defined at a low power level. If SOI and TOI are calculated at a power level where either P1 or Pn deviate from their low-power values, the results will be in error. To see this, sweep the input power and plot the IP3 of the Amplifier2 as a function of the input power. At low powers, the IP3 of the amplifier will match the TOI parameter set on the Amplifier2. Amplifier2 was constructed to have the TOI parameter as its IP3 at low powers so this is expected. As the input power increases, IP3 will start to deviate from the TOI value for low input powers. This simply reinforces the importance of calculating IP3 at low input powers. Too high, and IP3 changes. Note that it is not enough that the fundamental tone varies linearly. SOI/TOI is calculated based on the fundamental and the second/third-order intermod so one must ensure that the second/third-order intermods are also linear or SOI/TOI will change.

Note also that Amplifier2 must be output impedance matched in order for the SOI/TOI validation to check out.

12. The common expectation for the behavior of the adjacent channel power rejection (ACPR) for an amplifier operating in compression can be formulated in many equivalent ways: the ACPR decreases/improves as TOI increases; the ACPR decreases/improves as the amplifier becomes more linear; the ACPR decreases/improves as we move away from compression; the ACPR increases/worsens as TOI decreases; the ACPR increases/worsens as the amplifier becomes more nonlinear; the ACPR increases/worsens as we move towards compression. This expectation is correct for an amplifier operating linearly. For an amplifier operating in compression, the validity of this expectation depends on the amplifier. We will discuss two cases, a transistor-level amplifier and a polynomial amplifier.

The expectation may or may not be correct for a transistor-level amplifier operating in compression. A transistor-level simulation of a particular amplifier in ADS shows that this expectation holds at some input power ranges but not at others.

The expectation is incorrect for a polynomial amplifier operating in compression. [Modeling Basics](#) presented how two tones react when pushed through a polynomial amplifier and offered a discussion of this analysis. The result is that the large-signal gain will always exceed the small-signal gain. Applied to ACPR skirts, this means that a polynomial amplifier will actually produce a decreasing/better ACPR level as we move further into compression. This may be counter-intuitive but Amplifier2 reacts the way we can theoretically predict that a polynomial amplifier must act. Amplifier2's behavior is simply a function of the polynomial modeling on which it is based.

13. An S2D file typically consists of an ACDATA block containing small-signal information and a GCOMP i block (i = 1, ... , 7) containing compression information. For Amplifier2, the ACDATA block is ignored and the S-parameters specified on the Amplifier2 component are used. If the S-parameters of the ACDATA block must be used, use the AmplifierS2D component instead. Similarly, any NDATA blocks containing noise data are ignored by Amplifier2.
14. When an S2D file contains gain compression data at more than one frequency, the GainCompFreq must be set to one of the frequencies in the S2D file to identify the data to be used. It is imperative that GainCompFreq be set to one of the frequencies in the S2D file as no interpolation or extrapolation between gain compression data at different frequencies can be performed. For further details regarding GainCompFreq selectivity, refer to [Using GCFreq to Resolve GCOMP7 Frequency Conflicts](#) in the AmplifierS2D documentation.
15. When an S2D file has a power range that exceeds that of a simulation, a choice must be made for the power range used for fitting. Assume an S2D file covers -30 dBm to 30 dBm but that a simulation is carried out from -10 dBm to 10 dBm. In this case, a choice must be made as to whether the polynomial fitting of S2D data is done over the power range -30 dBm to 30 dBm or -10 dBm to 10 dBm. In the former case, the fitting may be inaccurate as the polynomial must cover a large power range that could hold a lot of variations. This is undesirable. However, the advantage of this approach is that the results we get when simulating from -10 dBm to 10 dBm are a subset of what we would have gotten in that interval had we simulated from -30 dBm to 30 dBm. In the latter case, the fitting is much more accurate as the fitting is done over a much smaller power range which presumably holds a lot less variation. This is desirable. However, the problem with this approach is that the results between -10 dBm and 10 dBm will be different for a simulation done from -30 dBm and 30 dBm rather than from -10 dBm and 10 dBm because the polynomial coefficients change as we change the power range of the simulation. ADS does the former. It fits a polynomial to the whole S2D file, not just the subset for

which the simulation is carried out. To change the fitting in a power range, it is not enough to change the power range of the simulation. To change the fitting, one must modify the S2D file. The S2D file power range, not the simulation power range, dictates the fitting power range. This is relevant in the following where we discuss different fittings in different power ranges.

16. A typical Pout (output power) vs. Pin (input power) curve consists of a linearly increasing region, a transition region and a saturation region. Another way of thinking of this is that typical Pout-Pin vs. Pin curve consists of a flat region, a transition region and a linearly decreasing region. When the saturation region is made larger and larger, the fitting approach adopted by Amplifier2 (polynomial fitting, odd order terms, order dependent upon the number of data points in the S2D file, max order 9) will tend to produce fitted curves which ring/oscillate more and more at higher powers. Mild ringing is often tolerable and might not even be noticed but if the transition region becomes too large it can make the results useless. To alleviate the problem, reduce the size of the saturation region to the minimum needed and leave no extra points in the S2D file. If the results are still not satisfactory, ensure ClipDataFile is set to yes and reduce the saturation region even more, relying on Amplifier2 extrapolation. If the results are still not satisfactory, try breaking the S2D file into two files and simulate the problem in two steps. Another alternative is to use the AmpSingleCarrier model. This model is based on linear interpolation instead of curve fitting and will not have this ringing problem. AmpSingleCarrier, however, will not produce harmonics. Refer to the AmpSingleCarrier documentation for details.
If fitted results do not accurately match the data in the S2D file and it is uncertain if this ringing problem is the cause, the problem is very easy to exaggerate. Simply extend the GCOMP7 block of the S2D file with a large flat region (more input powers, saturated output power, saturated output phase) and re-simulate. If the ringing problem is the cause, the results should get worse.
17. The S2D file capability is a legacy from OmniSys. OmniSys used GComp1-GComp7 data items for specifying gain compression. [Gain Compression Data for OmniSys and ADS](#) summarizes the gain compression data for OmniSys and ADS. Refer to [OmniSys Parameter Information](#) for OmniSys parameter information. GComp1-GComp6 can be specified by using the corresponding ADS gain compression parameters and setting GainCompType=LIST or they can be contained in an S2D format setting GainCompType=FILE.

OmniSys	ADS
GComp1: IP3	TOI
GComp2: 1dBc	GainComp=1dB
GComp3: IP3, 1dBc	TOI
GComp4: IP3, Ps, GCS	TOI
GComp5: 1dBc, Ps, GCS	GainComp=1dB
GComp6: IP3, 1dBc, Ps, GCS	TOI
GComp7	GainCompType=FILE

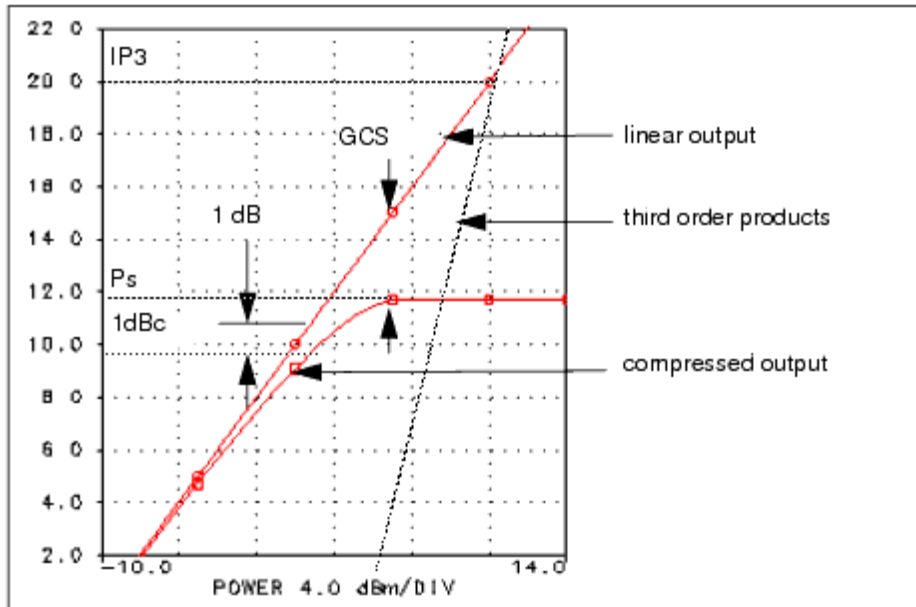

OmniSys Parameter Information

1. The GainRF component is the Ptolemy equivalent of the Analog/RF Amplifier2 component. Both of these components are based on the OmniSys legacy (refer to note 16) and the OmniSys cases GCOMP1 through GCOMP7 are shared by GainRF and Amplifier2. For GCOMP1 through GCOMP6 corresponding to GainCompType=LIST, the curve fitting algorithms for GainRF and Amplifier2 are very similar and close results can be expected. However, the curve fitting algorithms are not identical and the shape of the knees of the compression curves will therefore differ slightly. Also, the levels at which the various fundamentals saturate can be different. These levels will generally differ more when Psat is not set than when Psat is set. For GCOMP7 corresponding to GainCompType=FILE, the curve fitting algorithms for GainRF and Amplifier2 are different and different results can be expected.

AmplifierVC (Ideal Voltage-Controlled Amplifier)

Symbol

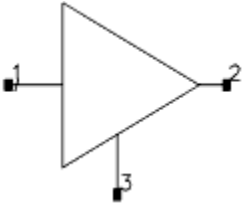

Available in ADS

Parameters

Name	Description	Units	Default
Gain	Gain as a function of control voltage (_v3)	dB/V	$(30 - 15 \times _v3)$
Rout	Output resistance	Ohm	50

Range of Usage

Rout > 0

Notes/Equations

1. AmplifierVC is an ideal voltage controlled amplifier. The impedance for its input and control port is infinite; its output impedance is Rout.
2. An equation is used to describe Gain as a function of the control voltage at port 3: _V3. The default equation is $\text{Gain} = 30 - 15 \times _V3$.

AmpSingleCarrier (Single Carrier Amplifier)

Symbol

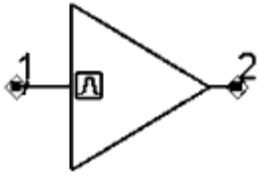

Available in ADS

Parameters

Name	Description	Units	Default
Freq	Frequency	None	None
S21	Forward transmission coefficient; use $x + j \times y$ polar (x,y), dbpolar (x, y) for complex value	None	None
S11	Forward reflection coefficient; use $x + j \times y$ polar (x,y), dbpolar (x, y), vswrpolar (x, y) for complex value	None	None
S22	Reverse reflection coefficient; use $x + j \times y$ polar (x,y), dbpolar (x, y), vswrpolar (x, y) for complex value	None	None
S12	Reverse reflection coefficient; use $x + j \times y$ polar (x,y), dbpolar (x, y) for complex value	None	None
NF	Noise figure	dB	None
NFmin	Minimum noise figure at Sopt	dB	None
Sopt	Optimum source reflection for minimum noise figure; use $x + j \times y$ polar (x,y), dbpolar (x, y) for complex value	None	None
Rn	Equivalent noise resistance	None	None

Z1	Reference impedance for port 1	None	None
Z2	Reference impedance for port 2	None	None
GainCompFile	Filename for Gain Compression (GCOMP7) Data	None	None

Notes/Equations

1. AmpSingleCarrier is based on FDD (frequency-domain defined device). The incident power level at the amplifier input is detected and the corresponding gain is obtained by interpolating the gain compression table given by GainCompFile. In harmonic balance simulation, the output signal has only one frequency component given by the Freq parameter. Neither harmonics nor intermodulation products are generated by AmpSingleCarrier. In Envelope simulation, the output signal contains only the complex envelope around one frequency given by the Freq parameter.
2. Z1 and Z2, the reference impedance parameters for ports 1 and 2, are used in conjunction with the parameters S11/S21/S12/S22. This is because S-data is always used with respect to a particular reference impedance.

FreqMult (Ideal Frequency Multiplier)

Symbol

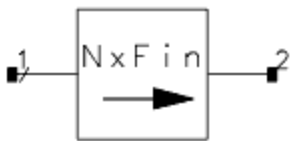

Available in ADS

Parameters

Name	Description	Units	Default
------	-------------	-------	---------

Advanced Design System 2008

S11	Complex reflection coefficient for port 1	None	0
S22	Complex reflection coefficient for port 2	None	0
G1	Power gain of input tone	dB	3
G2	Power gain of second harmonic relative to input tone	dB	None
G3	Power gain of third harmonic relative to input tone	dB	None
G4	Power gain of fourth harmonic relative to input tone	dB	None
G5	Power gain of fifth harmonic relative to input tone	dB	None
G6	Power gain of sixth harmonic relative to input tone	dB	None
G7	Power gain of seventh harmonic relative to input tone	dB	None
G8	Power gain of eighth harmonic relative to input tone	dB	None
G9	Power gain of ninth harmonic relative to input tone	dB	None
Pmin	Minimum input power for specified conversion	dBm	-40
Z1	Reference impedance for port 1	Ohm	50
Z2	Reference impedance for port 2	Ohm	50

Range of Usage

$$0 \leq |S_{11}| < 1$$

$$0 \leq |S_{22}| < 1$$

Notes/Equations

1. The ideal frequency multiplier takes an input signal and produces an output spectrum with specified spectral harmonics. The reverse isolation is assumed to be infinite ($S_{12}=0$). All of the harmonics generation is specified relative to the input level. For example if an input power of 20 dBm is incident on a multiplier with $G_2=-20$ dB the second harmonic output will be 0 dBm. This device is compatible with transient simulation.
2. This model assumes that only one signal tone is present at the input. If multiple tones are used at the input then unwanted mixing products can be generated and spurious mixing products will result.
3. The harmonic balance parameter ORDER must be set to a value equal to or higher than the harmonic index of interest.
4. Real-world nonlinear devices such as mixers and frequency multipliers often have an input power level below which they do not work. For FreqMult, this phenomenon is incorporated through the PMin parameter. However, PMin is not simply a minimum threshold value to which the input power is limited.
 With a right-propagating input wave of a_1 , the input power detection is done via $|a_1|^2 = a_1 \times a_1 + H(a_1) \times H(a_1)$, with $H(a_1)$ being the Hilbert transform of a_1 . A normalized a_1 is then calculated via $a_{1norm} = a_1 / \sqrt{|a_1|^2 + dBm2lin(PMin)}$, with $dBm2lin(x) = 10^{(x-30)/10}$. Note the presence of PMin. For $dBm2lin(PMin) \ll |a_1|^2$, the effect of PMin is negligible. For $|a_1|^2$ approaching $dBm2lin(PMin)$, however, the results will depend on the value of PMin. If this is undesired, simply lower PMin appropriately.
5. Z1 and Z2, the reference impedance parameters for ports 1 and 2, are used in conjunction with the parameters S11/S21/S12/S22. This is because S-data is always used with respect to a particular reference impedance.

LogACDemod (Demodulating AC Logarithmic Amplifier)

Symbol

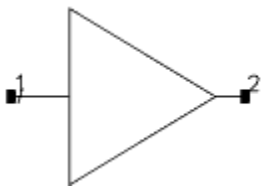

Available in ADS

Parameters

Name	Description	Units	Default
------	-------------	-------	---------

Advanced Design System 2008

CurrentSlope	Gradient of transfer characteristic	A/decade	1.e-3
VoltIntercept	Vin for zero output	V	1.e-3
Z1	Reference impedance for port 1	Ohm	50

Notes/Equations

1. LogACDemod uses a square-law detector and an ideal logarithmic function.
2. The function is in the form of voltage-input/current-output.
3. LogACDemod is not recommended for transient simulation.
4. Several logarithmic amplifiers are available in ADS: LogACDemod, LogDC, LogSuccDetect, and LogTrue. These components accept an RF input and generate a DC output voltage proportional to the log of the input voltage.

LogDC (DC Logarithmic Amplifier)

Symbol

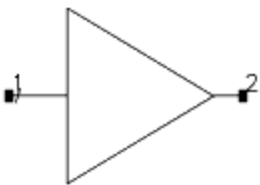

Available in ADS

Parameters

Name	Description	Units	Default
VoltSlope	Gradient of transfer characteristic	V/decade	1.e-3
VoltIntercept	Vin for zero output	V	1.e-3

Z1	Reference impedance for port 1	Ohm	50
----	--------------------------------	-----	----

Notes/Equations

1. LogDC provides an output that is a logarithmic function of the input. If, for example, the scaling is 1 volt/decade, the output changes by 1V for any tenfold increase of the input.
The intercept point is the input level at which the output voltage is 0.
 $V_{out} = \text{VoltSlope} \times \log((V_{in} / \text{VoltIntercept}) + 1)$
2. Several logarithmic amplifiers are available in ADS: LogACDemod, LogDC, LogSuccDetect, and LogTrue.
LogACDemod, LogSuccDetect, and LogTrue accept an RF input and generate a DC output voltage proportional to the log of the input voltage. LogDC will accept an RF input but does not generate a DC output.

LogSuccDetect (Successive Detection Logarithmic Amplifier)

Symbol

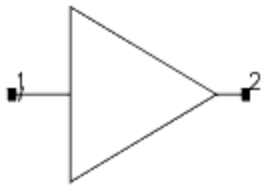

Available in ADS

Parameters

Name	Description	Units	Default
NumStages	Number of stages	None	5
StageGain	Gain per stage	dB	10
CurrentSlope	Gradient of transfer characteristic	A/decade	1.e-3

Z1	Reference impedance for port 1	Ohm	50
----	--------------------------------	-----	----

Notes/Equations

1. This amplifier use a successive detection scheme to provide an output current proportional to the logarithm of the input voltage. The amplifier consists of several amplifier/limiter stages (NumStages specifies how many), each having a small signal gain (StageGain specifies the gain). Each stage has an associated full-wave detector, whose output current depends on the absolute value of its input stage. These output currents are summed to provide the output scaled at the CurrentSlope (amp/decade). The output contains amplitude information only, regardless of any phase information. A simplified block diagram of this component is shown in [Simplified Block Diagram of a 5-Stage LogSuccDetect](#).

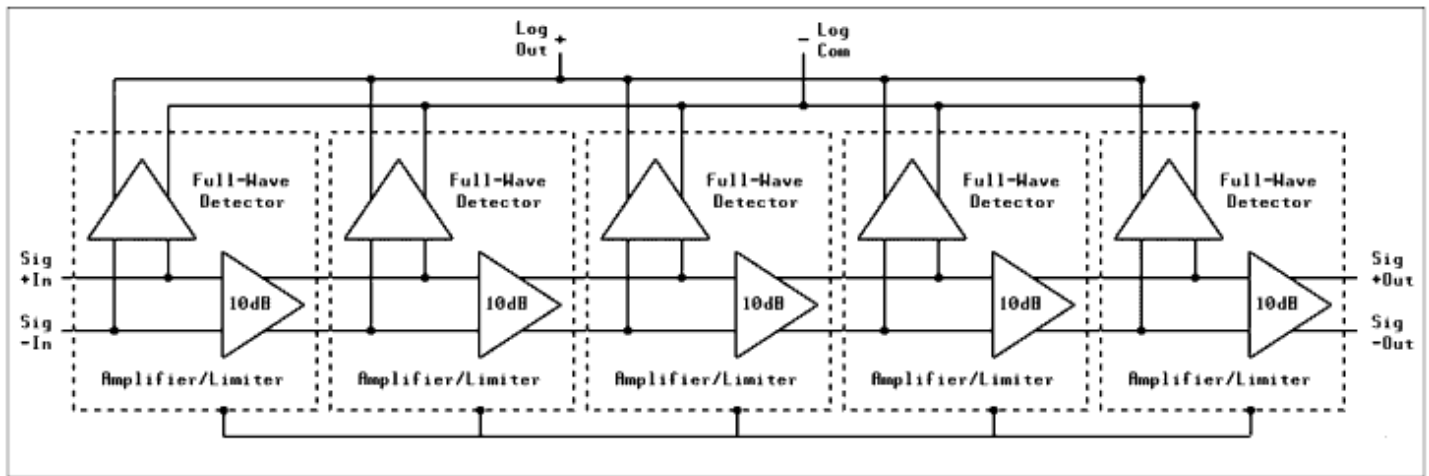

Simplified Block Diagram of a 5-Stage LogSuccDetect

1. Several logarithmic amplifiers are available in ADS: LogACDemod, LogDC, LogSuccDetect, and LogTrue. These components accept an RF input and generate a DC output voltage proportional to the log of the input voltage.

LogTrue (True Logarithmic Amplifier)

Symbol

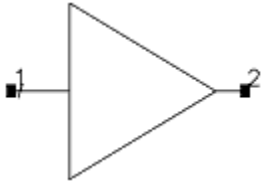

Available in ADS

Parameters

Name	Description	Units	Default
NumStages	Number of stages	None	5
StageGain	Gain per stage	dB	10
VoltLimit	Limiting voltage of each stage	V	1
Z1	Reference impedance for port 1	Ohm	50

Notes/Equations

1. LogTrue accepts inputs of either polarity and generates an output whose sign follows that of the input. A progressive compression technique is used, in which the logarithmic response can be approximated through the use of cascaded amplifier stages that have signal-dependent gain.
2. Several logarithmic amplifiers are available in ADS: LogACDemod, LogDC, LogSuccDetect, and LogTrue. These components accept an RF input and generate a DC output voltage proportional to the log of the input voltage.

Mixer (First RF System Mixer, Polynomial Model for Nonlinearity)

Symbol

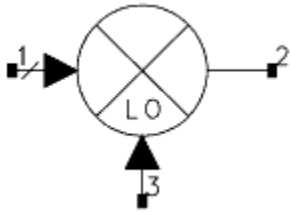

Available in ADS

Parameters

Name	Description	Units	Default
SideBand	Produce UPPER, LOWER, or BOTH sidebands at output port	None	UPPER
ImageRej	Image rejection at output with respect to fundamental	dB	None
LO_Rej1	LO to Input Port Rejection	dB	None
LO_Rej2	LO to Output Port Rejection	dB	None
RF_Rej	Input to Output Port Rejection	dB	None
ConvGain	Conversion Gain, use $x + j \times y$, $\text{polar}(x,y)$, $\text{dbpolar}(x,y)$ for complex value; see note 2)	None	$\text{dbpolar}(0,0)$
S11	Forward Reflection Coefficient, use $x + j \times y$, $\text{polar}(x,y)$, $\text{dbpolar}(x,y)$, $\text{vswrpolar}(x,y)$ for complex value; see note 2)	None	$\text{polar}(0,0)$
S22	Reverse Reflection Coefficient, use $x + j \times y$, $\text{polar}(x,y)$, $\text{dbpolar}(x,y)$, $\text{vswrpolar}(x,y)$ for complex value; see note 2)	None	$\text{polar}(0,180)$
S33	LO Port Reflection Coefficient, use $x + j \times y$, $\text{polar}(x,y)$, $\text{dbpolar}(x,y)$,	None	0

Advanced Design System 2008

	vswrpolar(x,y) for complex value; see note 2)		
PminLO	Minimum LO Power before starvation	None	None
NF	Double sideband noise figure	dB	None
NFmin	Minimum double sideband noise figure at Sopt	dB	None
Sopt	Optimum source reflection for minimum noise figure, use $x + j \times y$, polar(x,y), dbpolar(x,y) for complex value	None	None
Rn	Equivalent noise resistance		
Z1	Reference impedance for port 1 (real or complex number)		
Z2	Reference impedance for port 2 (real or complex number)		
Z3	Reference impedance for port 3 (real or complex number)		
ImpNoncausalLength	Non-causal function impulse response order	Integer	None
ImpMode	Convolution mode	Integer	None
ImpMaxFreq	Maximum frequency to which device is evaluated	None	
ImpDeltaFreq	Sample spacing in frequency	None	
ImpMaxOrder	Maximum allowed impulse response order	Integer	None
ImpWindow	Smoothing window	Integer	None
ImpRelTol	Relative impulse response truncation factor	None	None
ImpAbsTol	Absolute impulse response truncation factor	None	None

Range of Usage

Advanced Design System 2008

$NF \geq 0$ dB
 $NF_{min} > 0$
 $0 < \square_{Sopt} < 1$
 $0 < R_n$
 $GainCompFreq > 0$

$ConvGain > 0$

Gain Compression Parameters

Name	Description	Units	Default
GainCompType	Gain compression type: LIST=use model gain compression specifications; FILE=use file-based gain compression data	None	LIST
GainCompFreq	Reference frequency for gain compression (if gain compression is described as a function of frequency)		
ReferToInput	Specify gain compression with respect to input or output power of device	None	OUTPUT
SOI	Second order intercept	dBm	None
TOI	Third order intercept	dBm	None
Psat	Power level at saturation	dBm	None
GainCompSat	Gain compression at Psat	dB	5.0
GainCompPower	Power level in dBm at gain compression specified by GainComp	dBm	None
GainComp	Gain compression at GainCompPower	dB	1 dB
GainCompFile	Filename for gain compression data in S2D file format	None	None

Range of Usage for Gain Compression Parameters

When specifying gain compression using model parameters, only certain combination of parameters will produce

stable polynomial curve fitting. Recommended parameter combinations are listed here.

Note If unrealistic parameter values are used, the polynomial will become unstable, resulting in oscillations.

- Third-order intercept and 1dB gain compression parameters:
TOI, GainCompPower, with GainComp=1dB.
Range of validity: TOI > GainCompPower + 10.8.
- Third-order intercept and power saturation parameters:
TOI, Psat, GainCompSat.
Range of validity: TOI > Psat + 8.6.
- 1dB gain compression and power saturation parameters: GainCompPower, with GainComp=1dB, and Psat, GainCompSat.
Range of validity: Psat > GainCompPower + 3.
- Third-order intercept, 1dB gain compression and power saturation parameters:
TOI, GainCompPower with GainComp=1dB, and Psat, GainCompSat.
Range of validity: Psat > GainCompPower + 3, TOI > GainCompPower + 10.8
- Second-order intercept and third-order intercept parameters: SOI, TOI.

Notes/Equations

1. The Mixer component is similar to Mixer2. The key difference is that Mixer supports frequency conversion AC analysis or FCAC analysis for small-signal AC or S-parameter analysis, while Mixer2 does not. This capability allows small-signal frequency traditionally done at only one frequency to be somewhat extended to deal with more than one frequency. In terms of convergence, Mixer2 is typically more robust than Mixer, as the power detection is implemented differently.

2. If NFmin, Sopt, and Rn are used to characterize noise, the following relation must be satisfied for a realistic model.

$$\frac{Rn}{Zo} \geq \frac{To(Fmin - 1)|1 + Sopt|^2 (1 - |S11|^2)}{T^4 |1 - Sopt S11|^2}$$

A warning message will be issued if Rn does not meet this criterion. If the noise parameters attempt to describe a system that requires negative noise (due to Rn being too small), the negative part of the noise will be set to zero and a warning message will be issued.

3. Use the function polar(mag,ang) or dbpolar(dB, ang), or VSWR polar(VSWR, ang) to convert these specifications into a complex number.
4. For an S-parameter or a noise figure sinusoidal ripple, use the function ripple (mag, intercept, period, variable); for example ripple(0.1, 0, 10 MHz, freq).
Example: S21=dbpolar(10+ripple(),0.)
5. Z1, Z2 and Z3 the reference impedance parameters for ports 1, 2 and 3 are used in conjunction with the parameters S11/S21/S12/S22. This is because S-data is always used with respect to a particular reference impedance.
6. This model passes DC in the sense that a DC source at the RF input passes through the mixer to give a signal at the IF output.
7. In harmonic balance simulations, the PminLO parameter sets a threshold for the effect of the LO power on the mixer's conversion gain. The default value of PminLO is -100 dBm. The mixer will provide the expected

conversion gain if the LO power is significantly greater (~ 20 dB) than the value of P_{minLO} . If the LO power is less than this amount, the mixer's conversion gain will deteriorate in a nonlinear fashion.

8. Gain compression can be specified by using the gain compression model parameters, or this information can be contained in an S2D format file. All S2D gain compression types are supported by this model. Gain compression types 1 through 6 can also be described using the gain compression model parameters. Gain Compression 7 information must be contained in an S2D file. The GainCompType parameter instructs the model where to look for this data-in an S2D file or use model parameters.

For S2D data file format information refer to "Working with Data Files" in the Circuit Simulation manual.

9. Mixer operation with the SOI and TOI parameters is described in this note.

First consider an amplifier. Consider two input tones at f_1 and f_2 (assume $f_1 < f_2$) and at the same power level. Do a 2-tone HB simulation. The output will have first-order tones at f_1 and f_2 . It also have second-order intermod products at $f_2 - f_1$ and at $f_1 + f_2$. It will also have third-order intermod products at $2 \times f_1 - f_2$ (will be smaller than f_1 by $f_2 - f_1$) and $2 \times f_2 - f_1$ (will be greater than f_2 by $f_2 - f_1$). Drawing a picture of this frequency plan can be helpful. Based on these tones we can calculate the SOI and TOI of the amplifier. The general equation is $IP_n = (n \times P_1 - P_n) / (n - 1)$ where P_1 is the power level of the first-order tone and P_n is the power level of the n th-order tone. For SOI, we can use the power levels at f_1 and $f_2 - f_1$ or we can use the power levels at f_2 and $f_1 + f_2$. For TOI, we can use the power levels at f_1 and $2 \times f_1 - f_2$ or we can use the power levels at f_2 and $2 \times f_2 - f_1$.

For a mixer, everything is the same, except that everything is being shifted down (down-converting mixer) or up (up-converting mixer) by the LO frequency f_{LO} due to mixing. Therefore, all these frequencies will either have f_{LO} subtracted or added. Note that this means that from an HB point of view, we're calculating SOI off of second- and third-order intermod products and calculating TOI off of second- and fourth-order intermod products. For example, TOI can be calculated from a P_1 at $f_1 - f_{LO}$ (second-order as far as the HB simulation is concerned) and a P_n at $2 \times f_1 - f_2 - f_{LO}$ (fourth-order as far as the HB simulation is concerned).

Also, note that the mixer must be output-matched in order to validate SOI and TOI.

For more information about SOI and TOI, refer to the Amplifier2 component documentation.

10. Frequency Conversion AC (FCAC) analysis requires a single frequency at every node of a circuit. If Sideband=BOTH is specified for Mixer, the simulator will use SideBand=LOWER for FCAC analysis.
11. When Mixer is used in Transient analysis for single sideband applications, it is recommended that the user set Sideband=BOTH and insert a high-order filter to suppress the undesired sideband.

Mixer2 (RF System Mixer)

Symbol

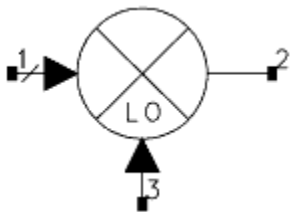

Advanced Design System 2008

Available in ADS and RFDE

Parameters

Name	Description	Units	Default
SideBand	Specify the sideband/image option for the mixe:	None	BOTH
OutputSidebandSuppression	Output sideband suppression (only relevant for SideBand=LOWER, UPPER)	dB	-200
InputImageRejection	Input image rejection (only relevant for SideBand=LOWER IMAGE REJECTION, UPPER IMAGE REJECTION)	dB	-200
ConvGain	Conversion gain; use $x + j \times y$, $\text{polar}(x,y)$, $\text{dbpolar}(x,y)$ for complex value	None	$\text{dbpolar}(0,0)$
RevConvGain	Reverse conversion gain, use $x + j \times y$, $\text{polar}(x,y)$, $\text{dbpolar}(x,y)$ for complex value	None	$\text{polar}(0,0)$
SP11	S11, RF port reflection, use $x + j \times y$, $\text{polar}(x,y)$, $\text{dbpolar}(x,y)$, $\text{vswrpolar}(x,y)$ for complex value	None	$\text{polar}(0,0)$
SP12	S12, IF port to RF port leakage, use $x + j \times y$, $\text{polar}(x,y)$, $\text{dbpolar}(x,y)$, $\text{vswrpolar}(x,y)$ for complex value	None	$\text{polar}(0,0)$
SP13	S13, LO port to RF port leakage, use $x + j \times y$, $\text{polar}(x,y)$, $\text{dbpolar}(x,y)$, $\text{vswrpolar}(x,y)$ for complex value	None	$\text{polar}(0,0)$
SP21	S21, RF port to IF port leakage, use $x + j \times y$, $\text{polar}(x,y)$, $\text{dbpolar}(x,y)$,	None	$\text{polar}(0,0)$

Advanced Design System 2008

	vswrpolar(x,y) for complex value		
SP22	S22, IF port reflection, use $x + j \times y$, polar(x,y), dbpolar(x,y), vswrpolar(x,y) for complex value	None	polar(0,0)
SP23	S23, LO port to IF port leakage, use $x + j \times y$, polar(x,y), dbpolar(x,y), vswrpolar(x,y) for complex value	None	polar(0,0)
SP31	RF port to LO port leakage (real or complex number)S31, RF port to LO port leakage, use $x + j \times y$, polar(x,y), dbpolar(x,y), vswrpolar(x,y) for complex value	None	polar(0,0)
SP32	IF port to LO port leakage (real S32, IF port to LO port leakage, use $x + j \times y$, polar(x,y), dbpolar(x,y), vswrpolar(x,y) for complex value or complex number)	None	polar(0,0)
SP33	LO port reflection (real or complex numS33, LO port reflection, use $x + j \times y$, polar(x,y), dbpolar(x,y), vswrpolar(x,y) for complex value or number)	None	polar(0,0)
PminLO	Minimum LO power before starvation	dBm	-100
DetBW	Detector bandwidth for LO limiting	Hz	1e100
NF	Double sideband noise figure	dB	None
NFmin	Minimum double sideband noise figure at Sopt	dB	None
Sopt	Optimum Source Reflection for Minimum Noise Figure, use $x + j \times y$, polar(x,y), dbpolar(x,y) for complex value	None	None

Advanced Design System 2008

Rn	Equivalent noise resistance		
Z1	Reference impedance for port 1 (must be a real number)	50	
Z2	Reference impedance for port 2 (must be a real number)	50	
Z3	Reference impedance for port 3 (must be a real number)	50	
GainCompType	Gain compression type:	None	LIST
GainCompFreq	reference frequency for gain compression if gain compression is described as a function of frequency		
ReferToInput	Specify gain compression with respect to input or output power of device:	None	OUTPUT
SOI	Second order intercept	dBm	None
TOI	Third order intercept	dBm	None
Psat	Power saturation point (always referred to output, regardless of the value of the ReferToInput parameter)	dBm	None
GainCompSat	Gain compression at Psat	dB	5.0
GainCompPower	Power level in dBm at gain compression for X dB compression point, specified by GainComp	dBm	None
GainComp	Gain compression at GainCompPower	dB	1.0 dB
AM2PM	Amplitude modulation to phase modulation	deg/dB	None
PAM2PM	Power level at AM2PM	dBm	None
GainCompFile	Filename for gain compression data in S2D file format	None	None
ClipDataFile	Clip data beyond maximum input power: YES=enable,	None	YES

Advanced Design System 2008

	NO=disable		
ImpNoncausalLength	Non-causal function impulse response order	Integer	None
ImpMode	Convolution mode	Integer	None
ImpMaxFreq	Maximum frequency to which device is evaluated	GHz	10
ImpDeltaFreq	Sample spacing in frequency		
ImpMaxOrder	Maximum allowed impulse response order	Integer	32
ImpWindow	Smoothing window	Integer	0
ImpRelTol	Relative impulse response truncation factor	None	None
ImpAbsTol	Absolute impulse response truncation factor	None	None

Frequently Asked Questions

Q1 : What are the major differences between Mixer and Mixer2?

A1 : Refer to [note 1](#).

Q2 : What are the supported parameter combinations?

A2 : Refer to [Range of Usage](#) .

Q3 : What is the range of usage for each parameter combination?

A3 : Refer to [Range of Usage](#).

Q4 : What are the port numbers and the terminology used for the signals at each port?

A4 : Refer to [Terminology](#).

Q5 : What is the basic implementation of Mixer2?

A5 : A Noisy2Port cascaded with an SDD . Refer to [Basic Implementation](#) for details.

Q6 : How does Mixer2 operate for the various SideBand modes?

A6 : Refer to [Sideband Suppression and Image Rejection](#).

Q7 : What is ConvGain?

A7 : It is the conversion gain. Refer to [Linear Behavior](#) for details.

Advanced Design System 2008

Q8 : How does Mixer2 apply a complex ConvGain?

A8 : Before the mixing, not after. Refer to [Linear Behavior](#) for details.

Q9 : What is RevConvGain?

A9 : It is the reverse conversion gain. Refer to [Linear Behavior](#) for details.

Q10 : What are SPIj (i,j=1,2,3)?

A10 : They are the reflection/leakage/isolation parameters or S-parameters. Refer to [Linear Behavior](#) for details.

Q11 : Are ConvGain, RevConvGain and SPIj (i,j=1,2,3) wave-based or voltage-based?

A11 : ConvGain is voltage-based, RevConvGain and SPIj are wave-based. Refer to [Linear Behavior](#) for details.

Q12 : How is RF to IF compression modeled?

A12 : A polynomial compression model is used. Refer to [Nonlinear Behavior](#) and [Modeling Basics](#) of the Amplifier2 documentation for details.

Q13 : How is AM to PM conversion modeled?

A13 : A polynomial AM to PM conversion model is used. Refer to [AM to PM Conversion](#) of the Amplifier2 documentation for details.

Q14 : How is LO limiting done for different DetBW values?

A14 : Via a filter with a variable bandwidth specified by DetBW or via a Hilbert transform. Refer to [LO Limiting](#) for details.

Q15 : What's best, small or large DetBW values?

A15 : Small for LO signals with significant harmonic content, large for bandpass LO signals. Refer to [LO Limiting](#) for details.

Q16 : How does PminLO influence the LO limiting?

A16 : It defines a lower limit for the effect of the LO power on the mixer's conversion gain. Refer to [LO Limiting](#) for details.

Q17 : Why does the mixer's conversion gain vary depending on the frequency content of the LO signal?

A17 : LO limiting is dynamic. Refer to [LO Limiting](#) for details.

Q18 : What noise model is used by Mixer2?

A18 : A Noisy2port , similar to Amplifier2. Refer to [Noise](#) for details.

Q19 : What are "NF-only mode" and "(NFmin,Sopt,Rn) mode" for in Mixer2?

A19 : They are two different ways of specifying noise. Refer to [Noise](#) for details.

Q20 : How is NFssb/NFdsb calculated, both at low powers and in compression?

A20 : Refer to [Noise](#).

Advanced Design System 2008

Q21 : Can you provide more details about the noise voltages and noise figures produced by Mixer2 for the different SideBand modes of operation?

A21 : Refer to [Noise](#).

Q22 : How can I lower the noise at the output of Mixer2?

A22: Refer to [Noise](#).

Q23 : Is there a tutorial example for Mixer2?

A23: examples/Tutorial/Mixer2_Example_prj . Refer to [note 2](#) for details.

Q24 : Does Mixer2 support frequency conversion AC (FCAC) analysis?

A24 : No. Refer to [note 3](#) for details.

Q25 : Why doesn't Mixer2 work for complex reference impedances?

A25 : Mixer2 does not support complex reference impedances. Refer to [note 4](#) for details.

Q26 : Can I use Mixer2 for baseband envelope simulations?

A26 : No. Refer to [note 6](#) for details.

Q27 : Why is Mixer2 sometimes slower than Mixer?

A27 : This is a consequence of the implementational differences between Mixer and Mixer2. Refer to [note 7](#) for details.

Q28 : Why don't the predicted second- and third-order intercept points match SOI and TOI as set on Mixer2?

A28 : You are probably not setting up your validation correctly. Make sure to do a two-tone simulation, not a one-tone simulation. Refer to [note 10](#) for details.

Q29 : Do sums/differences of two RF frequencies appear at the output of Mixer2?

A29 : It depends on SP21 and SOI. Refer to [note 11](#) for details.

Q30 : Why does Mixer2 ignore the ACDATA block of my S2D file?

A30 : It uses the S-parameters on the component instead. Refer to note 12 for details.

Q31 : When the power range in an S2D file differs from that of a simulation, which power range is used for polynomial fitting?

A31 : The power range in the S2D file. Refer to [note 14](#) for details.

Q32 : Why do I get ringing at high powers when using an S2D file?

A32 : This is a consequence of the polynomial model adopted by Mixer2. Refer to [note 15](#) for details.

Q33 : How do I get rid of this ringing?

A33: Eliminate data for high input powers, rely on extrapolation via ClipDataFile=yes, or break the S2D file into two. Refer to [note 15](#) for details.

$NF \geq 0$ dB

$NF_{min} \geq 0$ dB

$0 < \square_{Sopt} < 1$

$R_n > 0$

$GainCompFreq > 0$

$0 \text{ dB} < GainComp < 3 \text{ dB}$

When specifying gain compression using model parameters, only certain combination of parameters will produce stable polynomial curve fitting. If unrealistic parameter values are used, the polynomial will become unstable, resulting in oscillations. The recommended parameter combinations are listed here:

- Third-order intercept parameter:
Parameters: TOI
Range of validity: N/A
- Gain compression parameters:
Parameters: GainCompPower, GainComp
Range of validity: N/A
- Power saturation parameters:
Parameters: Psat, GainCompSat
Range of validity: N/A
- Third-order intercept and 1dB gain compression parameters:
Parameters: TOI, GainCompPower with GainComp=1dB
Range of validity: $TOI > GainCompPower + 10.8$
- Third-order intercept and power saturation parameters:
Parameters: TOI, Psat, GainCompSat
Range of validity: $TOI > Psat + 8.6$
- 1dB gain compression and power saturation parameters:
Parameters: GainCompPower with GainComp=1dB, Psat, GainCompSat
Range of validity: $Psat > GainCompPower + 3$
- Third-order intercept, 1dB gain compression and power saturation parameters:
Parameters: TOI, GainCompPower with GainComp=1dB, Psat, GainCompSat
Range of validity: $Psat > GainCompPower + 3$, $TOI > GainCompPower + 10.8$
- Second-order intercept and third-order intercept parameters:
Parameters: SOI, TOI
Range of validity: N/A

Terminology

This section outlines the terminology that will be used in the remainder of the Mixer2 documentation.

Mixer2 is a 3-port device. Its input port is numbered port 1, its output port is numbered port 2, and its local oscillator port is numbered port 3. The signals at the three ports will be denoted by RF, IF, and LO, respectively, as illustrated in [Mixer Terminology](#). This follows the receiver/down-conversion convention. This convention has RF and IF flipped relative to the transmitter/up-conversion convention. When Mixer2 is used for transmitter/up-conversion applications, RF therefore refers to the input signal and IF refers to the output signal.

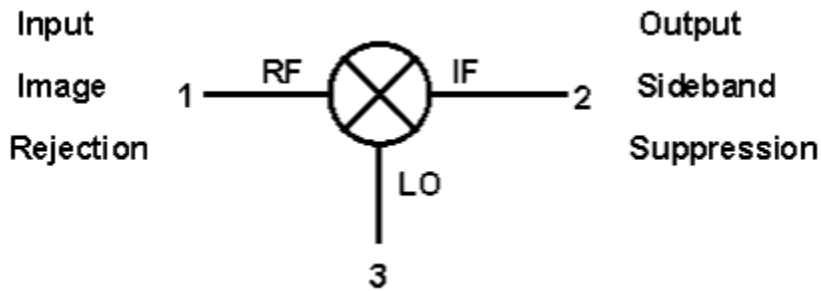

Mixer Terminology.

The primary signal of interest at the input of the mixer is the RF signal. A secondary signal of interest at the input of the mixer is the RF image, denoted RF_{img} , defined as the other input signal which results in IF as a second-order mixing product. The input image is typically only of interest for receiver/down-conversion applications, in which case it is given by $RF_{img} = 2 * LO - RF$. RF and $RF_{img} = 2 * LO - RF$ both mix down with LO to generate $IF = |LO - RF|$ at the output. The signals RF and RF_{img} are called images of each other with respect to LO. If RF_{img} is attenuated relative to RF, we talk about image rejection .

The primary signals of interest at the output of the mixer are $|LO - RF|$ and $LO + RF$. Typically, one of these is desired and the other is undesired. We refer to these two signals as lower and upper sidebands . If one sideband is attenuated relative to the other, we talk about sideband suppression .

Throughout the Mixer2 documentation, we will use the terms image and rejection when describing input signals to Mixer2 and use the terms sideband and suppression when describing output signals from Mixer2. Other choices are possible but the terminology adopted here is in line with accepted industry literature, see for example the exhaustive mixer applications notes from WJ Communications. The only exception is that the Mixer2 SideBand parameter controls both the image and the sideband operation of the mixer, not just the sideband operation. The reason for this is compatibility with previous versions of Mixer2.

Basic Implementation

The basic implementation of Mixer2 is a Noisy2Port cascaded with an SDD. The parameters NF, NFmin, Sopt, Rn and Z1 are passed to the Noisy2Port and noise is generated. The signal is not affected by the generation of noise but goes unaltered through the Noisy2Port. All parameters except NF, NFmin, Sopt and Rn are then passed to the SDD and the signal and noise goes through the SDD. The SDD implements a linear mixer which allows compression from RF to IF and from RF to LO. Different circuit topologies are used for realizing sideband suppression and image rejection mixers, but the overall implementation is the same - a Noisy2Port cascaded with an SDD. This basic knowledge of the implementation may help understand some of the following sections.

Sideband Suppression and Image Rejection

A mixer can pass both the lower and the upper input image, reject the lower input image, or reject the upper input

image. Similarly, a mixer can generate both the lower and the upper output sideband, generate the lower sideband only, or generate the upper sideband only. Various combinations of these are possible. To explain the image rejection and sideband suppression features for Mixer2, we will look at a receiver/down-conversion example.

Given RF and LO for a down-converting mixer, we have $IF = |LO - RF|$. Also of interest is the RF image given by $RF_{img} = 2*LO - RF$. If RF is below LO, RF_{img} is above LO. Similarly, if RF is above LO, RF_{img} is below LO. We will use RF_1 to denote the signal below LO and RF_2 to denote the signal above LO. If $RF = RF_1$, then $RF_{img} = RF_2$. Similarly, if $RF = RF_2$, then $RF_{img} = RF_1$. RF_1 and RF_2 both mix down to $LO - RF_1 = RF_2 - LO$. RF_1 and RF_2 mix up to $RF_1 + LO$ and $RF_2 + LO$. This is illustrated in [Frequency Plan for Image Rejection and Sideband Suppression.](#)

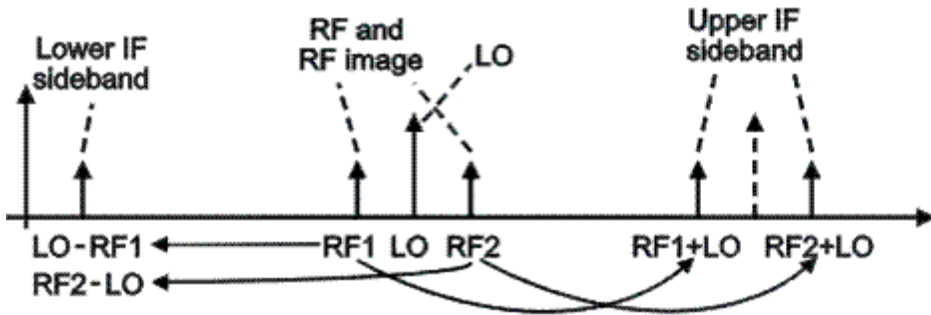

Frequency Plan for Image Rejection and Sideband Suppression.

We will use this to explain the five supported SideBand parameters and the use of OutputSidebandSuppression and InputImageRejection. Note that this illustration has a receiver/down-conversion bias as $LO \sim RF$. For a transmitter/up-conversion application, RF would generally be much closer to zero and LO would generally be much closer to $|LO - RF|$ and $LO + RF$. However, all principles remain the same and we can use the above example to explain all SideBand options.

For SideBand=BOTH, both input images are passed through the mixer without rejection and both output sidebands are generated without suppression. This mode is the default for Mixer2. A normal circuit level mixer without external filtering operates in this manner. OutputSidebandSuppression and InputImageRejection are ignored for this mode. This is illustrated in [Mixer2 image/sideband operation for SideBand=BOTH.](#)

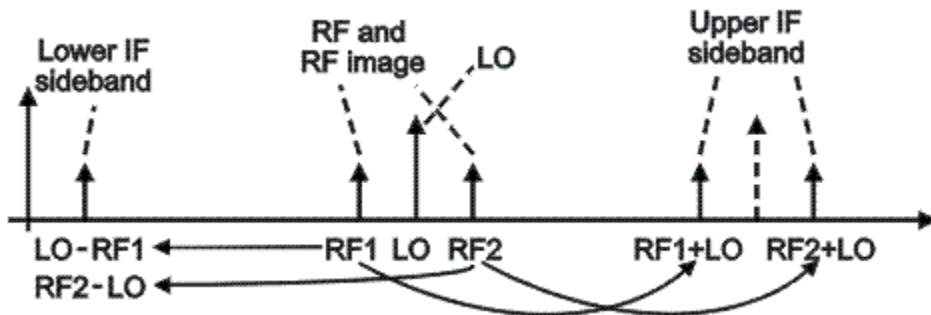

Mixer2 image/sideband operation for SideBand=BOTH.

For SideBand=LOWER, both input images are passed through the mixer without rejection and the undesired upper output sideband is suppressed by the amount given by OutputSidebandSuppression relative to the desired lower output sideband. This mode is a down-conversion mode used for receiver applications. The default value for OutputSidebandSuppression is -200 dB. InputImageRejection is ignored for this mode. This is illustrated in [Mixer2 image/sideband operation for SideBand=LOWER.](#)

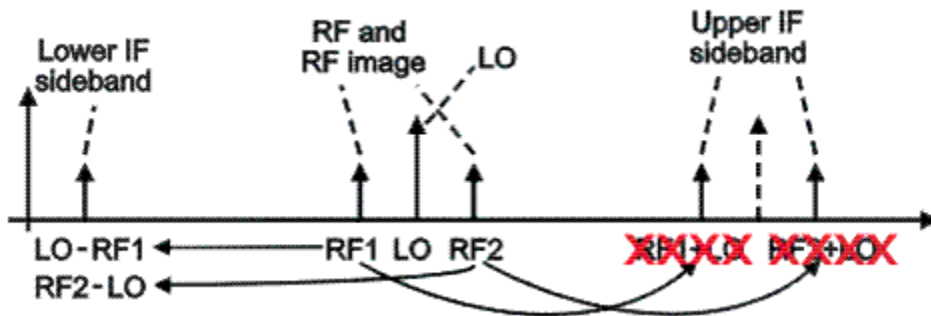

Mixer2 image/sideband operation for SideBand=LOWER.

For SideBand=UPPER, both input images are passed through the mixer without rejection and the undesired lower output sideband is suppressed by the amount given by OutputSidebandSuppression relative to the desired upper output sideband. This mode is an up-conversion mode used for transmitter applications. The default value for OutputSidebandSuppression is -200 dB. InputImageRejection is ignored for this mode. This is illustrated in [Mixer2 image/sideband operation for SideBand=UPPER.](#)

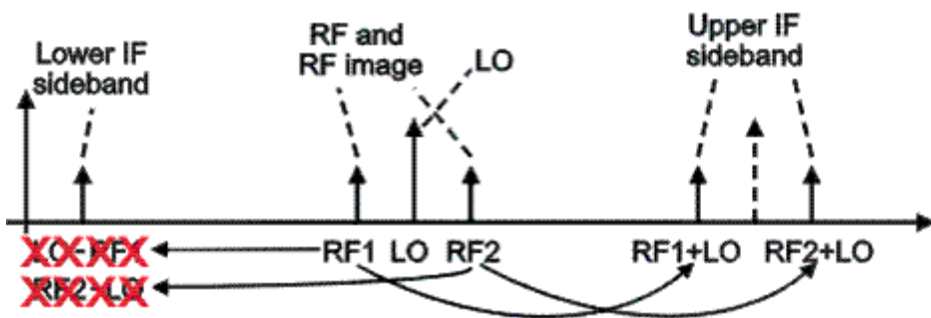

Mixer2 image/sideband operation for SideBand=UPPER.

For SideBand=LOWER IMAGE REJECTION, the lower input image is rejected by the amount given by InputImageRejection relative to the upper input image and both output sidebands are suppressed by the amount given by InputImageRejection. This upper sideband behavior is not intuitive but since this mode is almost exclusively used for receiver/down-conversion applications, the upper output sideband is generally not of much interest. The default value for InputImageRejection is -200 dB. OutputSidebandSuppression is ignored for this mode. This is

illustrated in [Mixer2 image/sideband operation for SideBand=LOWER IMAGE REJECTION.](#)

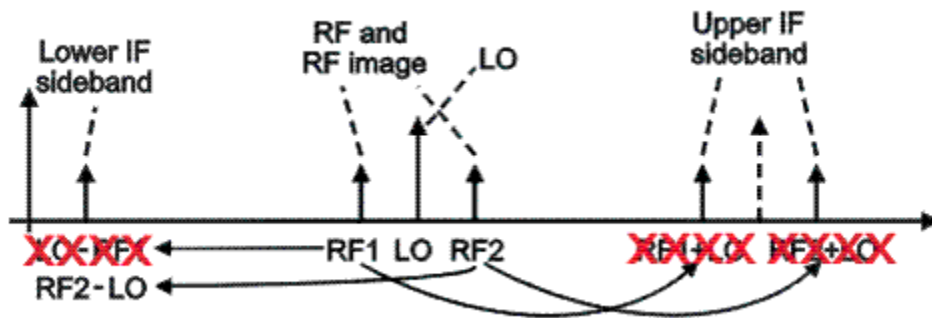

Mixer2 image/sideband operation for

SideBand=LOWER IMAGE REJECTION.

For SideBand=UPPER IMAGE REJECTION, the upper input image is rejected by the amount given by InputImageRejection relative to the lower input image and both output sidebands are generated without suppression. Since this mode is almost exclusively used for receiver/down-conversion applications, the upper output sideband is generally not of much interest. The default value for InputImageRejection is -200 dB. OutputSidebandSuppression is ignored for this mode. This is illustrated in [Mixer2 image/sideband operation for SideBand=UPPER IMAGE REJECTION.](#)

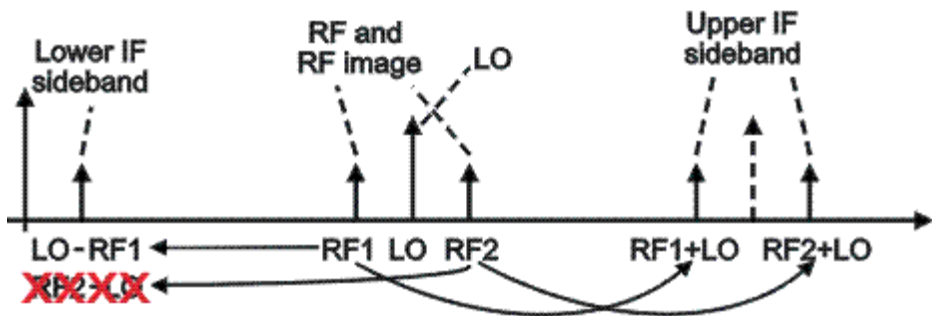

Mixer2 image/sideband operation for

SideBand=UPPER IMAGE REJECTION.

Other combinations of input image rejection and output sideband suppression exist which are not supported by Mixer2. None of these modes are of much practical relevance.

The InputImageRejection and OutputSidebandSuppression parameters do not support image or sideband enhancement. The input image rejection and output sideband suppression is abs (InputImageRejection) and abs (OutputSidebandSuppression). The signs of InputImageRejection and OutputSidebandSuppression do not matter. The operation of Mixer2 for SideBand=BOTH emulates the behavior of a single mixer. The operation of Mixer2 for SideBand=LOWER and SideBand=UPPER emulates the behavior of a single mixer with a filter at the output. The

operation of Mixer2 for SideBand=LOWER IMAGE REJECTION and SideBand=UPPER IMAGE REJECTION emulates the behavior of a mixing sub-system constructed from two single mixers, a phase shifter, and possibly other components. Since circuit-level mixers pass both input images and generate both output sidebands, a practical design process will typically end up using Mixer2 with SideBand=BOTH when the design is finalized. This, however, does not render the other four modes any less valuable. If a design uses a mixer suppressing the lower/upper output sideband, SideBand=UPPER or SideBand=LOWER will typically be used in the beginning stages of the design process. As the design is finalized and more physical realism is desired, a switch to SideBand=BOTH can be made and output filters can be added. Similarly, if a design uses a mixing sub-system rejecting the lower/upper input image, SideBand=LOWER IMAGE REJECTION or SideBand=UPPER IMAGE REJECTION will typically be used in the beginning stages of the design process. As the design is finalized and more physical realism is desired, a switch to SideBand=BOTH can be made and an actual image rejection mixing sub-system can be built from mixers with SideBand=BOTH. Such design processes take advantage of many features offered by Mixer2.

Linear Behavior

The linear behavior of Mixer2 is described by the conversion gain ConvGain, the reverse conversion gain RevConvGain, and the nine reflection/leakage/isolation parameters (S-parameters) SPij (i,j=1,2,3).

The ConvGain parameter is the conversion gain from RF to IF. It is applied to the lower sideband |RF-LO| and the upper sideband RF+LO. Either of these sidebands can then be suppressed by OutputSidebandSuppression, as described in the "Sideband Suppression and Image Rejection" section.

If ConvGain is real, it will simply scale the output sidebands. To understand the behavior of Mixer2 when ConvGain is complex, consider a Mixer2 with SideBand=BOTH. Given an LO, we consider RF1 below LO and RF2 above LO. In a Harmonic Balance simulation, Mixer2 will down-convert to |RF1-LO|=LO-RF1 and |RF2-LO|=RF2-LO and up-convert to RF1+LO and RF2+LO. If signals with non-zero phases are applied at RF1 and RF2, the phases will transfer directly to the output tones at RF2-LO, RF1+LO and RF2+LO. However, the phase at LO-RF1 will be inverted. The reason is that RF1-LO is a negative frequency and that the simulator therefore solves for the result at the corresponding positive frequency -(RF1-LO)=LO-RF1 and then conjugates the result. This conjugation is what manifests itself in the phase reversal for the LO-RF1 output tone. It has nothing to do with Mixer2. It is a Harmonic Balance concept which can also be seen with Mixer and VMult. For Mixer2, the phase of ConvGain is applied in an analogous manner. It is applied before the mixing of RF with LO takes place and before any compression from RF to LO is applied, not after. The phase of ConvGain is therefore subjected to the mixing process which means, per above, that the phase of ConvGain will be added to the output tones at RF2-LO, RF1+LO and RF2+LO but subtracted from the output tone at LO-RF1. Mixer, on the other hand, simply applies the phase of ConvGain to all output tones regardless of any mixing taking place. The approach for Mixer2 is consistent with the underlying mixing process and appears much more appealing than that for Mixer.

The RevConvGain parameter, the reverse conversion gain from IF to RF, is similar to ConvGain, except no compression is associated with RevConvGain. Also, the phase of RevConvGain is applied after the mixing, not before. For most applications, RevConvGain will be zero.

The SPij (i,j=1,2,3) parameters describe the port reflection and port-to-port leakage/isolation for the mixer. Mixer2 is a three-port device and in line with established theory for generalized S-parameters we denote the voltages and currents at port n by vn and in and define the input and output waves at each port as:

$$a_n = (v_n + Z_n * i_n) / (2 * \sqrt{Z_n})$$

$$b_n = (v_n - Z_n * i_n) / (2 * \sqrt{Z_n})$$

with Zn being the reference impedance for port n. This is illustrated in [Definition of Voltages, Currents and Waves.](#)

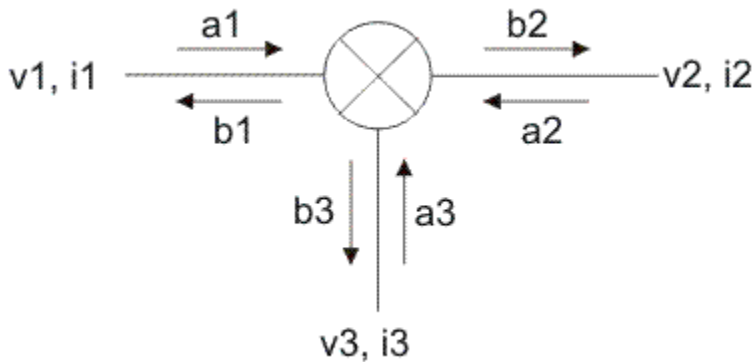

Definition of Voltages, Currents and Waves.

The nine S-parameters SP_{ij} ($i,j=1,2,3$) are then defined through

$$b_1 = SP_{11} \cdot a_1 + SP_{12} \cdot a_2 + SP_{13} \cdot a_3$$

$$b_2 = SP_{21} \cdot a_{1_poly} + SP_{22} \cdot a_2 + SP_{23} \cdot a_3$$

$$b_3 = SP_{31} \cdot a_{1_poly} + SP_{32} \cdot a_2 + SP_{33} \cdot a_3$$

where, relative to normal generalized S-parameters, two instances of a_1 have been replaced by a_{1_poly} which is the a_1 wave with polynomial compression taken into account.

SP_{11} , SP_{21} and SP_{31} operate on a_1 or a_{1_poly} and are therefore defined at the frequencies present at the RF port. $SP_{11} \cdot a_1$, $SP_{21} \cdot a_{1_poly}$ and $SP_{31} \cdot a_{1_poly}$ are therefore contributions at the RF/IF/LO port at the frequencies present at the RF port. Similarly, SP_{12} , SP_{22} and SP_{32} operate on a_2 and are therefore defined at the frequencies present at the IF port. $SP_{12} \cdot a_2$, $SP_{22} \cdot a_2$ and $SP_{32} \cdot a_2$ are therefore contributions at the RF/IF/LO port at the frequencies present at the IF port. Similarly, SP_{13} , SP_{23} and SP_{33} operate on a_3 and are therefore defined at the frequencies present at the LO port. $SP_{13} \cdot a_3$, $SP_{23} \cdot a_3$ and $SP_{33} \cdot a_3$ are therefore contributions at the RF/IF/LO port at the frequencies present at the LO port. All three ports have contributions at all frequencies. If SP_{ij} were normal generalized S-parameters for a three-port, b_i , a_j and SP_{ij} would all be defined at the same frequency. The extension to the case of multiple frequencies appears natural so S-parameter terminology was chosen for Mixer2.

SP_{11} is the RF reflection, SP_{12} is the IF to RF leakage/isolation, SP_{13} is the LO to RF leakage/isolation, SP_{21} is the RF to IF leakage/isolation, SP_{22} is the IF reflection, SP_{23} is the LO to IF leakage/isolation, SP_{31} is the RF to LO leakage/isolation, SP_{32} is the IF to LO leakage/isolation, and SP_{33} is the LO reflection.

$ConvGain$, $RevConvGain$ and SP_{ij} ($i,j=1,2,3$) are specified as complex numbers. Use the functions $polar(magnitude, angle)$, $dbpolar(dB, angle)$, or $VSWRpolar(VSWR, angle)$ to convert the $ConvGain$, $RevConvGain$ and SP_{ij} specifications into complex numbers. For example, if a reflection/leakage is X dB, use $dbpolar(-X, 0)$.

$ConvGain$, $RevConvGain$ and SP_{ij} ($i,j=1,2,3$) are voltage gains and not power gains. For instance, a mixer with $ConvGain=polar(10, 0)$ will scale the voltage by a factor of 10 from input to output and will therefore result in a 20 dB increase in power. $ConvGain=dbpolar(10, 0)$, on the other hand, will result in a 10 dB increase in power.

As outlined above, SP_{ij} ($i,j=1,2,3$) are wave-based. The same is true for $RevConvGain$. $ConvGain$, on the other hand, is voltage-based, not wave-based. $ConvGain$ applies to the input voltage, not the input wave. However, $ConvGain$ is not blindly applied to the input voltage v_1 at the RF port. Doing so would make the RF to IF conversion dependent on SP_{11} as a modified SP_{11} results in a different b_1 and therefore changes v_1 . In keeping with the measurement standards used to define mixer conversion gain at the system level, the reflected wave due to SP_{11} is not included. This means that if we change SP_{11} from 0 to something finite, we will see no change in IF output power because the reflected wave is not taken into account when mixing from RF to IF. The same holds true for S-parameters. With a fixed SP_{21} , the RF to IF leakage does not depend on SP_{11} . This applies to other S-parameters in an analogous

manner.

To illustrate the difference between wave-and voltage-based parameters, consider a mixer with an RF source, LO source and IF termination. The RF input wave a1 is finite but the RF output wave b1 is zero. Similarly, the LO input wave a3 is finite but the LO output wave b3 is zero. The mixing results in a finite IF output wave b2 but the IF input wave a2 is zero. Now add LO to RF leakage through a finite LO_Rej1 (Mixer) or SP13 (Mixer2) parameter. This will result in a signal at the LO frequency at the RF port and generate a finite b1 wave. Assuming no reflection at the RF source, this will not change the a1 wave. The a1 wave will not have any content at the LO frequency.

Mixer has a wave-based ConvGain parameter. The RF to IF conversion is based on the a1 wave. Since the a1 wave does not change when a finite LO_Rej1 is added, neither will the RF to IF conversion. Specifically, no RF signal at the LO frequency will mix with LO to produce IF output at DC and twice the LO frequency. Thus, Mixer will produce zero DC output. Mixer2, on the other hand, has a voltage-based ConvGain parameter. The RF to IF conversion is based on the RF input voltage, not the a1 wave. Since the RF input voltage changes when a finite SP13 is added, so will the conversion. Specifically, the RF signal at the LO frequency will mix with LO to produce, absent of sideband suppression, IF output at DC and twice the LO frequency. Thus, Mixer2 will produce a finite DC output. However, note that that Mixer2 will not produce a direct feed-through IF output at the LO frequency if SP21 is finite. The S-parameters, as stated above, are wave-based, not voltage-based. They operate on a1, not v1.

Nonlinear Behavior

The nonlinear behavior of Mixer2 is described by a number of different list- and file-based options for specifying compression. A polynomial compression model is used. For detailed information about the polynomial modeling of compression, please see [Modeling Basics](#) and [AM to PM Conversion](#) in the documentation for Amplifier2. The compression options for Mixer2 and Amplifier2 are identical, as is the underlying modeling.

Amplifier2 applies compression from its input to its output. In an analogous manner, Mixer2 applies compression from RF to IF. In addition, Mixer2 also applies the same compression from RF to LO. There is no guarantee that the compression from RF to LO is the same as that from RF to IF for an actual mixer, but applying this compression from RF to LO seems more reasonable than to not apply compression from RF to LO.

LO Limiting

Under typical operating conditions, a circuit-level mixer's LO is saturated. This means that the RF to IF mixing process is insensitive to the actual value of the LO signal. A small fluctuation in LO power will not change the RF to IF mixing. A mixer is not a voltage multiplier. To mimic this behavior for Mixer2, the LO is limited. Mixer limits the LO based on a filtered detector signal. Prior to Release 2004A, Mixer2 limited the LO based on the magnitude of the Hilbert transform of the LO signal. Starting in Release 2004A, Mixer2 allows limiting based on both a filtered detector signal and the magnitude of the Hilbert transform of the LO signal, with the latter being the default. Instead of the brick wall DC-only filter used for Mixer, it is now a single pole roll-off with a variable bandwidth specified by DetBW. For extremely large bandwidths (1e12 Hz and above), this switches to Hilbert transform limiting. Hilbert transform limiting (large DetBW values) is best for bandpass LO waveforms with multiple signals but does rather poorly when an LO with significant harmonics is used, as analytic signal calculations such as instantaneous magnitude do not apply to broadband signals. For an LO with significant harmonics, filtered detector signal limiting (small DetBW values) should be used. A circuit-level mixer has an LO power level below which its behavior changes dramatically. To mimic this behavior for Mixer2, Mixer2 has a PminLO parameter which sets a limit for the effect of the LO power on the mixer's conversion

gain. Mixer2 adds this power level to the limited LO power level (limited via a filtered detector signal for $\text{DetBW} \leq 1\text{e}12$ Hz and via the magnitude of the Hilbert transform for $\text{DetBW} > 1\text{e}12$ Hz) in order to arrive at the total LO power level. Note that the model does not simply switch to using P_{minLO} when the limited LO power level falls below P_{minLO} . It is a gradual transition and not a threshold. When the limited LO power level is much larger than P_{minLO} , the effect of P_{minLO} on the conversion gain is negligible. As the limited LO power level approaches P_{minLO} , the conversion gain will depend on the value of P_{minLO} in a nonlinear manner. If this is undesirable, lower P_{minLO} . The LO power is not a fixed quantity but is computed dynamically from the signal at the LO port. This means that Mixer2's conversion gain will vary depending on the frequency content of the LO signal. Frequency content other than the primary LO signal could come from harmonics of the primary LO signal or from spurious LO signals. If the dependence of the LO power on the LO frequency content is undesired, a bandpass filter can be added to the LO path. Filtered detector signal limiting and Hilbert transform limiting behave differently when an LO sideband enters Mixer2. Consider the case of $\text{RF}=0.1$ GHz, $\text{LO}=1.0$ GHz, $|\text{LO}-\text{RF}|=0.1$ GHz, and $\text{LO}+\text{RF}=1.9$ GHz. Assuming an RF power of -20 dBm, an LO power of 0 dBm and a conversion gain of 0 dB, we get -20 dBm IF power at both sidebands. Now add a 1.01 GHz tone at -30 dBm at LO. Filtered detector signal limiting gives zero power at 0.09 GHz and 1.89 GHz and -50 dBm power at 0.11 GHz and 1.91 GHz. Hilbert transform limiting, on the other hand, generates intermodulation products and gives -56 dBm power at 0.09 GHz, 0.11 GHz, 1.89 GHz, and 1.91 GHz. This supports the recommendation to use Hilbert transform limiting (high DetBW values, the default for Mixer2) unless significant harmonics are present at LO.

Mixer2 does not have an LO common mode leakage parameter which would allow the specification of the amount of LO common mode leakage to be present at the output. For a two-tone LO, the LO common mode leakage is the level of the sum and difference intermodulation products of the two LO tones. A workaround to realize this is to add an Amplifier2 component in the LO path, set its SOI/TOI parameters to generate the appropriate sum/difference tones, and set SP23 on Mixer2 to leak these tones from LO to IF.

Noise

Given the minimum noise figure NF_{min} (real), the optimal reflection coefficient S_{opt} (complex), the noise resistance R_n (real), the noise reference impedance R_{ref} (real), and the source admittance Y_s (complex), the noise figure NF of an amplifier is determined by

$$Y_{\text{opt}} = \frac{1}{R_{\text{ref}}} \times \frac{1 - S_{\text{opt}}}{1 + S_{\text{opt}}}$$

$$F_{\text{min}} = 10^{\text{NF}_{\text{min}}/10}$$

$$F = F_{\text{min}} + \frac{R_n}{\text{Real}[Y_s]} \times |Y_s - Y_{\text{opt}}|^2$$

$$\text{NF} = 10 \times \log(F)$$

Note that this is independent of the amplifier S-parameters.

The noise behavior of Amplifier2 is characterized by the four noise parameters NF , NF_{min} , S_{opt} and R_n and the reference impedance Z_1 for port 1. Amplifier2 is implemented as a Noisy2Port cascaded with an SDD. The above-mentioned five parameters control the parameters for the Noisy2Port, the Noisy2Port generates a noise voltage

on its output and this noise voltage is passed through the SDD in the same manner as the signal.

The noise behavior of Mixer2 mimics that of Amplifier2. Similar to Amplifier2, Mixer2 is implemented as a Noisy2Port cascaded with an SDD. The parameters NF, NFmin, Sopt, Rn and Z1 are passed to the Noisy2Port and noise is generated. The signal is not affected by the generation of noise but goes unaltered through the Noisy2Port. All parameters except NF, NFmin, Sopt and Rn are then passed to the SDD and the signal and noise goes through the SDD. The Noisy2Port part of Mixer2 is identical to that of Amplifier2 and the noise at the output of the Noisy2Port for Amplifier2 and Mixer2 will consequently be the same if the noise parameters and reference impedances are the same. The difference between Amplifier2 and Mixer2 is the SDD that follows the Noisy2Port.

NF-only mode is used for NFmin=0. This is a special case where only one noise parameter must be specified. In this case, the Noisy2Port has the parameters NFmin=NF, Sopt=0, and Rn=Z1/4 × (10 NF/10 -1). The reference impedance for the noise calculation (not available on the Noisy2Port user interface) is Z1. The NFmin=0, Sopt and Rn parameters are ignored.

(NFmin, Sopt, Rn) mode is used for NFmin>0. This is a more general case than NF-only mode. In this case, the Noisy2Port has the parameters NFmin=NFmin, Sopt=Sopt, and Rn=Rn. The reference impedance for the noise calculation (not available on the Noisy2Port user interface) is Z1. The NF parameter is ignored.

Given an output noise voltage v_n , the single sideband noise figure NFssb and the double sideband noise figure NFdsb are given by

$$NF_{ssb} = 10 \cdot \log\left(\frac{v_n^2 / R + k \times T_0 \times (G_1 + G_2 + \dots)}{k \times T_0 \times G_1}\right)$$

$$NF_{dsb} = 10 \cdot \log\left(\frac{v_n^2 / R + k \times T_0 \times (G_1 + G_2 + \dots)}{k \times T_0 \times (G_1 + G_2 + \dots)}\right)$$

where R is the output resistance, $k = 1.380658e-23$ J/K is Boltzmann's constant, $T_0 = 290$ K is the standard noise temperature, G_1 is the primary power gain from the input noise frequency to the output noise frequency, and $G_2 + \dots$ is the sum of all higher order mixing gains which mix from some input frequency to the output noise frequency. For an amplifier, $G_2 + \dots$ is zero under small-signal operation. The same holds true for a mixer with input image rejection. For a mixer without input image rejection, G_2 is significant and often equal to G_1 under small-signal operation while $G_3 + \dots$ is zero under small-signal conditions. v_n^2 / R represents the noise added by the component(s) while $k \times T_0$ represents the noise power available from the input termination.

The documentation for Amplifier2 outlines how Amplifier2 calculates noise voltages and noise figures in various cases and compares this to the behavior of Amplifier. Due to the similarities between Amplifier2 and Mixer2, much of this material is also relevant for Mixer2. As mentioned above, the difference between Amplifier2 and Mixer2 is not the generation of noise by the Noisy2Port but how this noise is translated through the SDD that follows. For more information about noise voltages, please see the documentation for Amplifier2.

The NF-only and (NFmin,Sopt,Rn) noise modes are covered above and many details about the computation of noise voltages for Noisy2Port are given in the Amplifier2 documentation. The last remaining aspect to be understood is the influence of SideBand, OutputSidebandSuppression and InputImageRejection on the noise voltages and noise figures. To this end, consider a Mixer2 with a given LO. We choose $RF < LO$. The lower output sideband is $LSB = LO - RF$ and the upper output sideband is $USB = RF + LO$. The input image for down-conversion is $LSB_Img = 2*LO - RF$ (LSB_Img mixes down with LO to give LSB) and the input image for up-conversion is $USB_Img = 2*LO + RF$ ($-USB_Img$ mixes up with LO to give $-USB$). This is illustrated in [Frequency plan for noise computation.](#)

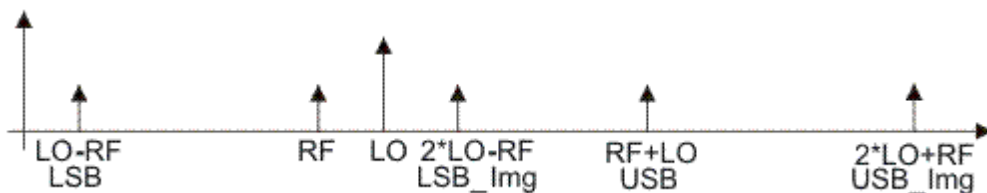

Frequency plan for noise computation.

Advanced Design System 2008

We will use Mixer2 in NF-only mode. The results carry over directly to (NFmin,Sopt,Rn) mode. We operate the mixer at low RF powers. We let NF=5.00 dB. Since NF is the double sideband noise figure, we expect Mixer2 to give NFdsb=NF in all cases. This is exactly what Mixer2 gives, see [Noise Results](#). NFssb, on the other hand, depends on SideBand, OutputSidebandSuppression and InputImageRejection. From the expressions for NFssb and NFdsb, we see that

$$NF_{ssb} = NF_{dsb} + 10 \cdot \log \left(\frac{G_1 + G_2 + \dots}{G_1} \right)$$

Letting all gain terms above G2 to zero and substituting NF for NFdsb, we expect

$$NF_{ssb} = NF + 10 \cdot \log \left(1 + \frac{G_2}{G_1} \right)$$

In the following, we will explain the influence of SideBand, OutputSidebandSuppression and InputImageRejection on NFssb.

{anchor:1143203}Noise Results

					LSB		USB	
SideBand	Rejection/dB	Suppression/dB	NF/ dB	v.noise/pV	_NFdsb/dB	_NFssb/dB	_NFdsb/dB	_NFssb/dB
BOTH	N/A	N/A	5.00	930.5	5.00	8.01	5.00	N/A
LOWER IM REJ	0	N/A	5.00	930.5	5.00	8.01	N/A	N/A
LOWER IM REJ	-10	N/A	5.00	690.0	5.00	5.41	N/A	N/A
LOWER IM REJ	-200	N/A	5.00	657.9	5.00	5.00	N/A	N/A
UPPER IM REJ	0	N/A	5.00	930.5	5.00	8.01	N/A	N/A
UPPER IM REJ	-10	N/A	5.00	690.0	5.00	5.41	N/A	N/A
UPPER IM REJ	-200	N/A	5.00	657.9	5.00	5.00	N/A	N/A
LOWER	N/A	0	5.00	930.5	5.00	8.01	N/A	N/A
LOWER	N/A	-10	5.00	930.5	5.00	8.01	N/A	N/A
LOWER	N/A	-200	5.00	930.5	5.00	8.01	N/A	N/A
UPPER	N/A	0	5.00	930.5	N/A	N/A	5.00	8.01
UPPER	N/A	-10	5.00	690.0	N/A	N/A	5.00	5.41
UPPER	N/A	-200	5.00	657.9	N/A	N/A	5.00	5.00

For SideBand=BOTH, we get NFssb=8.01 dB=NF+3.01 dB for both the lower and the upper sideband.

OutputSidebandSuppression and InputImageRejection are both ignored in this case. Since this case offers no image rejection, we have $G_2=G_1$ and the expression for NFssb confirms the result by Mixer2.

For SideBand=LOWER IMAGE REJECTION and SideBand=UPPER IMAGE REJECTION, we get an NFssb value that varies from NF+3.01 dB to NF as InputImageRejection is changed from 0 dB (no rejection, same as SideBand=BOTH) to -200 dB. Since these SideBand modes are intended for down-conversion applications only, the noise figure for the upper sideband does not matter. OutputSidebandSuppression is ignored in this case. With no rejection, we have $G_2=G_1$ and the expression for NFssb confirms the result by Mixer2. With full rejection, we have $G_2=0$ and the expression for NFssb confirms the result by Mixer2. In between, we have $G_2=10^{(\text{InputImageRejection}/10)}G_1$ and expect to get $\text{NFssb}=\text{NF}+10*\log(1+10^{(\text{InputImageRejection}/10)})$. For InputImageRejection=-10, this evaluates to NFssb=NF+0.41 dB and confirms the result by Mixer2.

For SideBand=LOWER, we get NFssb=NF+3.01 dB as OutputSidebandSuppression is changed from 0 dB (no suppression, same as SideBand=BOTH) to -200 dB. Since this SideBand mode is intended for down-conversion applications only, the noise figure for the upper sideband does not matter. InputImageRejection is ignored in this case. With no suppression, we have $G_2=G_1$ and the expression for NFssb confirms the result by Mixer2. As we change OutputSidebandSuppression, all we do is change the conversion gain to the upper sideband. This should have no effect on the noise in the lower sideband, our sideband of interest. Indeed, we keep having $G_2=G_1$ and the expression for NFssb confirms the result by Mixer2.

For SideBand=UPPER, we get an NFssb value that varies from NF+3.01 dB to NF as OutputSidebandSuppression is changed from 0 dB (no suppression, same as SideBand=BOTH) to -200 dB. Since this SideBand mode is intended for up-conversion applications only, the noise figure for the lower sideband does not matter. InputImageRejection is ignored in this case. With no suppression, we have $G_2=G_1$ and the expression for NFssb confirms the result by Mixer2. As we change OutputSidebandSuppression, we change the conversion gain to the lower sideband. As for SideBand=LOWER, we might expect this to have no effect on the noise in the upper sideband, our sideband of interest. However, the input image USB_Img is above USB in this case and therefore is subjected to the conversion gain to the lower sideband which is being changed by OutputSidebandSuppression. An upper sideband mixer is, in effect, an image rejection mixer. With full suppression, we have $G_2=0$ and the expression for NFssb confirms the result by Mixer2. In between, we have $G_2=10^{(\text{OutputSidebandSuppression}/10)}G_1$ and expect to get $\text{NFssb}=\text{NF}+10*\log(1+10^{(\text{OutputSidebandSuppression}/10)})$. For OutputSidebandSuppression=-10, this evaluates to NFssb=NF+0.41 dB and confirms the result by Mixer2.

Noise can be contributed and lowered in several ways. To see this, consider a down-converting mixer with a certain RF and LO. IF is $|RF-LO|$ and RFimg is $2*LO-RF$. Output noise at IF can be a result of noise at RF and RFimg mixing with LO to contribute noise at IF but can also be a result of noise at IF leaking directly through the mixer from RF or LO if it has a finite RF/LO to IF leakage. This output noise at IF can be lowered if the mixer is an image rejection mixer that rejects the signal/noise contribution at RFimg or if the mixer has no RF/LO to IF leakage. In the absence of a mixer with such properties, output noise at IF can be lowered external to the mixer by adding filters at the RF and LO ports which eliminate the input noise at RFimg and IF (RF port) and IF (LO port). Eliminating the noise at RF is much harder since adding a filter at RF will also eliminate the desired signal at RF.

Notes/Equations

1. Mixer2 is introduced as a replacement for Mixer for anything but frequency conversion AC analysis (see note 3). To change an existing Mixer component to a Mixer2 component, change the name from Mixer to Mixer2 on the schematic. Many parameters for the two models are the same and Mixer2 will adopt the values for Mixer, making parameter re-entry unnecessary. The only exception is that the parameters SideBand, GainCompType and ReferToInput will take their default values BOTH, LIST and OUTPUT, respectively, regardless of the values these parameters had for Mixer. The Mixer parameters ImageRej, LO_Rej1, LO_Rej2, RF_Rej, S11, S22 and S33

Advanced Design System 2008

correspond to the Mixer2 parameters OutputSidebandSuppression, SP13, SP23, SP21, SP11, SP22 and SP33 and will have to be re-entered. In addition, Mixer2 has the new parameters InputImageRejection, SP12, SP31, SP32, DetBW, AM2PM, PAM2PM and ClipDataFile whose values cannot be deduced from Mixer and will therefore take their default values. Also, the Mixer display settings will be ignored. Mixer2 will adopt its default settings, displaying SideBand and ConvGain. [Major Differences between Mixer and Mixer2](#) summarizes the major differences between Mixer and Mixer2

Major Differences between Mixer and Mixer2.

Mixer	Mixer2
Image rejection not supported	Image rejection supported
Reverse conversion gain not supported	Reverse conversion gain supported
Some leakage terms supported	All leakage terms supported
Real/imaginary polynomial fit	Magnitude/phase polynomial fit
AM to PM not supported	AM to PM supported for all magnitude modes
One type of LO limiting	More flexible LO limiting
Complex ConvGain leads to non-physical behaviors	Complex ConvGain leads to physical behaviors
FCAC analysis supported	FCAC analysis not supported
For large harmonic balance and circuit envelope simulations Mixer2 may be slower than Mixer.	

1. For a tutorial example of how to use Mixer2 in various cases, see examples/Tutorial/Mixer2_Example_prj. For other examples of how to use Mixer2, search the ADS examples for the Mixer2 component.
2. Mixer supports frequency conversion AC (FCAC) analysis for small-signal AC or S-parameter analysis, while Mixer2 does not. This capability allows small-signal frequency analysis traditionally done at only one frequency to be somewhat extended to deal with more than one frequency. It is not as accurate as harmonic balance analysis. If FCAC analysis is needed, use Mixer. If not, use Mixer2.
3. Mixer2 does not support complex reference impedances.
4. Mixer2 passes dc.
5. Mixer2 is not recommended for baseband envelope applications.
6. Mixer2 may be slower than Mixer for large harmonic balance and circuit envelope simulations.
7. When using Mixer2 in transient simulations, Mixer2 gives a warning about non-causality of the H(2), H(15) and H(18) weighting functions. Please ignore this warning.
8. When setting up simulations with Mixer2, make sure to avoid colliding tone issues where multiple mixing products map to the same frequency. Setups with colliding tones should be changed so colliding tones are eliminated.
9. This note describes Mixer2 operation with the SOI and TOI parameters set. SOI and TOI are used for specifying the second-order and third-order intercept points IP2 and IP3.
The general equation for the nth order intercept point IPn is $IPn = (n * P1 - Pn) / (n - 1)$ where P1 is the power level of the first-order tone and Pn is the power level of the nth-order tone. The latter power level, however, is not unique. It can be based on either harmonics or intermods, and the two will generally not be the same. If the formula $IPn = (n * P1 - Pn) / (n - 1)$ works for one type of second- and third-order tone, it will not work for the other.

The industry standard for IP_n is based on intermods, and the same goes for the SOI and TOI parameters for Mixer2. IP_n must therefore be validated using a two-tone setup, not a one-tone setup. Note that IP_n is defined at a low power level. If IP_n is computed at a power level where either P_1 or P_n deviate from their low-power values, the results will be in error. Note that it is not enough that the fundamental tone varies linearly. IP_n is computed based on the fundamental tone and a higher-order intermod so one must ensure that the higher-order intermod is also linear or IP_n will change. Also, note that IP_n is defined under output-matched conditions.

While the basic definition of the power levels used for computing IP_n are the same for an amplifier and a mixer, this is not the case for the frequencies at which these power levels are evaluated.

For an amplifier with two input tones at f_1 and f_2 (assume $f_1 < f_2$) at the same power level, a two-tone harmonic balance simulation will result in first-order tones at f_1 and f_2 , second-order intermod products at $f_2 - f_1$ and at $f_1 + f_2$, and third-order intermod products at $2 \times f_1 - f_2$ (will be smaller than f_1 by $f_2 - f_1$) and $2 \times f_2 - f_1$ (will be greater than f_2 by $f_2 - f_1$). For computing $IP_2 = SOI$, we can use the power levels at f_1 and $f_2 - f_1$ or we can use the power levels at f_2 and $f_1 + f_2$. For computing $IP_3 = TOI$, we can use the power levels at f_1 and $2 \times f_1 - f_2$ or we can use the power levels at f_2 and $2 \times f_2 - f_1$.

For a mixer, everything is the same except that all frequencies are being shifted down (down-converting mixer) or up (up-converting mixer) by the LO frequency f_{LO} due to mixing. Therefore, all these frequencies will either have f_{LO} subtracted or added. Note that this means that from a harmonic balance point of view, $IP_2 = SOI$ is calculated off of second- and third-order intermod products and $IP_3 = TOI$ is calculated off of second- and fourth-order intermod products. For computing $IP_2 = SOI$, we can use the power levels at $f_1 \pm f_{LO}$ (second-order as far as the harmonic balance simulation is concerned) and at $f_2 - f_1 \pm f_{LO}$ (third-order as far as the harmonic balance simulation is concerned) or we can use the power levels at $f_2 \pm f_{LO}$ (second-order as far as the harmonic balance simulation is concerned) and at $f_1 + f_2 \pm f_{LO}$ (third-order as far as the harmonic balance simulation is concerned). For computing $IP_3 = TOI$, we can use the power levels at $f_1 \pm f_{LO}$ (second-order as far as the harmonic balance simulation is concerned) and at $2 \times f_1 - f_2 \pm f_{LO}$ (fourth-order as far as the harmonic balance simulation is concerned) or we can use the power levels at $f_2 \pm f_{LO}$ (second-order as far as the harmonic balance simulation is concerned) and at $2 \times f_2 - f_1 \pm f_{LO}$ (fourth-order as far as the harmonic balance simulation is concerned).

10. When the RF port is excited with two tones, the down/up-converted sum/difference frequencies are present at the IF port. What about the sum/difference frequencies themselves? The difference frequency can be very important for a zero-IF down-converting mixer. The answer is that the sum/difference frequency level at the IF port depends on SP_{21} and SOI. For $SP_{21} = 0$, the sum/difference frequency level is zero. For finite SP_{21} values, the sum/difference frequency level depends on SOI. The sum/difference frequency level will be zero at zero input power and will rise linearly with the expected 2:1 slope as the input power level is increased. Consequently, the sum/difference frequency level gets more and more significant as the input power gets closer and closer to SOI. At a high enough input power level, the sum/difference frequency level compresses. If SOI is excessively high, the sum/difference frequency level remains low for all realistic input powers. The shape of the curve is determined by SOI and can be scaled by varying SP_{21} . The sum/difference frequency level will experience a sharp increase when the mixer starts hard limiting, regardless of the SP_{21} and SOI values. For an explanation of why this happens, see the "Modeling Basics" section of the Amplifier2 documentation. All this is also true at the LO port, except that SP_{31} controls this level.
11. An S2D file typically consists of an ACDATA block containing small-signal information and a GCOMP $_i$ block ($i=1, \dots, 7$) containing compression information. For Mixer2, the ACDATA block is ignored and the S-parameters specified on the Mixer2 component are used. Similarly, any NDATA blocks containing noise data are ignored by Mixer2.
12. When an S2D file contains gain compression data at more than one frequency, the GainCompFreq must be set to one of the frequencies in the S2D file to identify the data to be used. It is imperative that GainCompFreq be set to one of the frequencies in the S2D file as no interpolation or extrapolation between gain compression data at different frequencies can be performed.
13. When an S2D file has a power range that exceeds that of a simulation, a choice must be made for the power range used for fitting. Assume an S2D file covers -30 dBm to 30 dBm but that a simulation is carried out from

-10 dBm to 10 dBm. In this case, a choice must be made as to whether the polynomial fitting of S2D data is done over the power range -30 dBm to 30 dBm or -10 dBm to 10 dBm. In the former case, the fitting may be inaccurate as the polynomial must cover a large power range that could hold a lot of variations. This is undesirable. However, the advantage of this approach is that the results we get when simulating from -10 dBm to 10 dBm are a subset of what we would have gotten in that interval had we simulated from -30 dBm to 30 dBm. In the latter case, the fitting is much more accurate as the fitting is done over a much smaller power range which presumably holds a lot less variation. This is desirable. However, the problem with this approach is that the results between -10 dBm and 10 dBm will be different for a simulation done from -30 dBm and 30 dBm rather than from -10 dBm and 10 dBm since the polynomial coefficients change as we change the power range of the simulation. ADS does the former. It fits a polynomial to the whole S2D file, not just the subset for which the simulation is carried out. To change the fitting in a power range, it is not enough to change the power range of the simulation. To change the fitting, one must modify the S2D file. The S2D file power range, not the simulation power range, dictates the fitting power range. This is relevant in the following where we shall discuss different fittings in different power ranges.

14. A typical Pout (output power) vs. Pin (input power) curve consists of a linearly increasing region, a transition region and a saturation region. Another way of thinking of this is that typical Pout-Pin vs. Pin curve consists of a flat region, a transition region and a linearly decreasing region. When the saturation region is made larger and larger, the fitting approach adopted by Mixer2 (polynomial fitting, odd order terms, order dependent upon the number of data points in the S2D file, max order 9) will tend to produce fitted curves which ring/oscillate more and more at higher powers. Mild ringing is often tolerable and might not even be noticed but if the transition region becomes too large it can make the results useless. To alleviate the problem, reduce the size of the saturation region to the minimum needed and leave no extra points in the S2D file. If the results are still not satisfactory, make sure ClipDataFile is set to yes and reduce the saturation region even more, relying on Mixer2 extrapolation. If the results are still not satisfactory, try breaking the S2D file into two files and simulate the problem in two steps. If fitted results do not accurately match the data in the S2D file and it is uncertain if this ringing problem is the cause, the problem is very easy to exaggerate. Simply extend the GCOMP7 block of the S2D file with a large flat region (more input powers, saturated output power, saturated output phase) and re-simulate. If the ringing problem is the cause, the results should get worse.
15. The S2D file capability is a legacy from OmniSys. OmniSys used GComp1-GComp7 data items for specifying gain compression. [Gain Compression Data for OmniSys and ADS](#) summarizes the gain compression data for OmniSys and ADS. Refer to [OmniSys Parameter Information](#) for OmniSys parameter information. GComp1-GComp6 can be specified by using the corresponding ADS gain compression parameters and setting GainCompType=LIST or they can be contained in an S2D format setting GainCompType=FILE.

OmniSys	ADS
GComp1: IP3	TOI
GComp2: 1dBc	GainComp=1dB
GComp3: IP3, 1dBc	TOI
GComp4: IP3, Ps, GCS	TOI
GComp5: 1dBc, Ps, GCS	GainComp=1dB
GComp6: IP3, 1dBc, Ps, GCS	TOI
GComp7	GainCompType=FILE

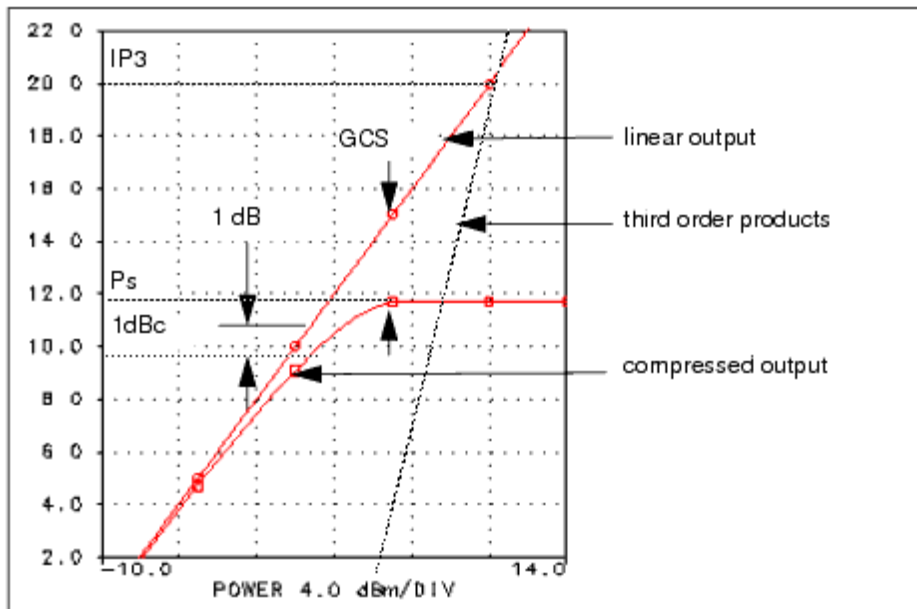

OmniSys Parameter Information

MixerWithLO (Mixer with Internal Local Oscillator)

Symbol

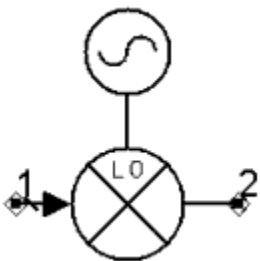

Available in ADS

Advanced Design System 2008

Parameters

Name	Description	Units	Default
ZRef	Reference impedance for all ports	Ohm	50
DesiredIF	Desired mixer IF output signal (used for Budget analysis only)	None	RF plus LO
ConvGain	Conversion gain, use $x + jy$, $\text{polar}(x,y)$, $\text{dbpolar}(x,y)$ for complex value	None	$\text{dbpolar}(0,0)$
SP11	Port 1 reflection, use $x + jy$, $\text{polar}(x,y)$, $\text{dbpolar}(x,y)$, $\text{vswrpolar}(x,y)$ for complex value	None	$\text{polar}(0,0)$
SP22	Port 2 reflection, use $x + jy$, $\text{polar}(x,y)$, $\text{dbpolar}(x,y)$, $\text{vswrpolar}(x,y)$ for complex value	None	$\text{polar}(0,180)$
NF	Double sideband noise figure	dB	1
ReferToInput	Specify gain compression with respect to input or output power of device: OUTPUT=refer to output; INPUT=refer to input	None	OUTPUT
SOI	Second order intercept	dBm	1000
TOI	Third order intercept	dBm	1000
LO_Freq	Mixer local oscillator frequency	GHz	1

Range of Usage

ZRef > 0
 DesiredRF = 0 (RF plus LO), 1 (RF minus LO)
 \square SPij \square > 0 (ij=11; 22)
 NF \geq 0 dB
 LO_Freq > 0

Notes/Equations

1. MixerWithLO is a two port mixer model with internal oscillator.
2. This component is a schematic design that uses internal models for Mixer2 and I_1Tone. The schematic design is shown here:

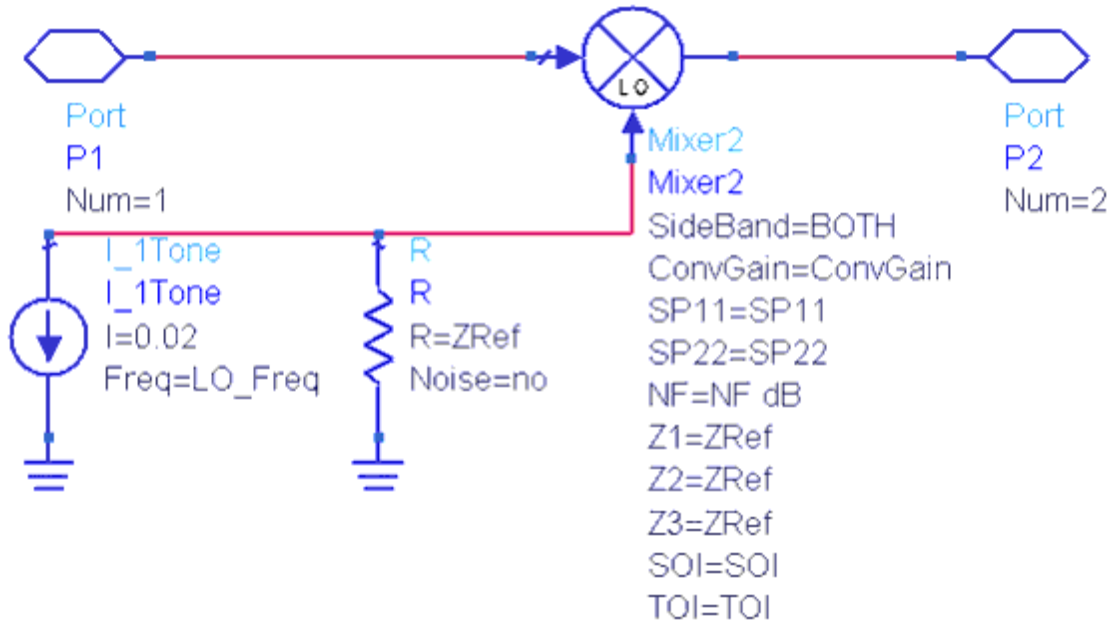

3. See documentation for the internal components Mixer2 and I_1Tone for their usage detail.
4. The internal Mixer2 model has parameter SideBand=BOTH. This MixerWithLO outputs both the RF+LO and RF-LO sidebands. However, there is no RF or LO leakage.
5. Internal to the Mixer2 model, the NF parameter is used to set the Mixer2 parameters for $NF_{min}=NF$, $S_{opt}=0$, and $R_n=\max(Z_{Ref}/4 \times (10^{NF/10} - 1), \text{tinyreal})$, where tinyreal is an internal simulator value for the smallest real value allowed.
6. For use with Budget Analysis, the DesiredRF parameter identifies which of the output sidebands is to be tracked for Budget measurements.
7. Regarding SOI and TOI, the MixerWithLO must be output-matched in order to validate SOI and TOI.

By default, SOI and TOI are blank resulting in no nonlinearity. TOI may be set without setting SOI. However, if SOI is set, then setting TOI is required. For more information about SOI and TOI, refer to the Mixer2 component documentation.

1. Examples demonstrating this model use in a Budget analysis are located in the ADS Examples area at: [\\$HPESOF_DIR/examples/Tutorial/RF_Budget_Examples_prj](#). See Budget_Mixer.dsn.

OpAmp (Operational Amplifier)

Symbol

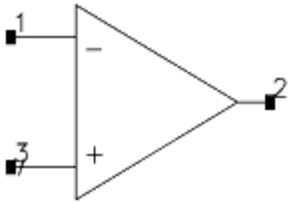

Available in ADS

Parameters

Name	Description	Units	Default
Gain	Open loop DC gain of amplifier	dB	100
CMR	Common mode rejection ratio	dB	None
Rout	Output resistance	Ohm	100
RDiff	Differential input resistance	MOhm	1
CDiff	Differential input capacitance	F	0
RCom	Common mode input resistance	MOhm	1
CCom	Common mode input capacitance	F	0
SlewRate	Signal slew rate	V/sec	1e+6
IOS	Input offset current	A	0
VOS	Input offset voltage	V	0
BW	Gain bandwidth product (unity gain bandwidth)	MHz	1
Pole1	Dominant pole frequency (overrides BW parameter)		
Pole2	Additional higher order pole frequency		
Pole3	Additional higher order pole frequency		

Advanced Design System 2008

Pole4	Additional higher order pole frequency		
Pole5	Additional higher order pole frequency		
Zero1	Feed forward zero frequency		
Inoise	Input spectral noise current	A/sqrt(Hz)	0
Vnoise	Input spectral noise voltage	V/sqrt(Hz)	0
VEE	Negative supply voltage	V	15
VCC	Positive supply voltage	V	15
DeltaVEE	Delta difference between saturated voltage and negative supply voltage (see note 4)	V	0.3
DeltaVCC	Delta difference between saturated voltage and positive supply voltage (see note 4)	V	0.3

Range of Usage

RDiff > 0
 CDiff > 0
 RCom > 0
 CCom > 0
 by default:
 CMR = ∞
 Pole2 = ∞
 Pole3 = ∞
 Pole4 = ∞
 Pole5 = ∞
 Zero1 = ∞

Notes/Equations

- The BW parameter is the GainBandwidth product, i.e. it is the frequency at which the gain is unity or 0 dB. Pole1 is the basic amplifier pole and corresponds to the frequency where the gain starts sloping downward. BW and Pole1 can be specified simultaneously; however, if both are entered, Pole1 will override BW, and Pole1 must then be entered as BW/Gain. The Gain parameter is the open loop gain of the opamp and it must be

converted out of dB only for use in setting Pole1, i.e., $\text{Gain} = 10^{\text{Gain_dB}/20}$.

2. To match the phase shift from the data sheet, adjust the values of Pole2 through Pole5.
3. Zero1 is used for operational amplifiers with feed-forward or lead-lag compensation networks.
4. Output voltage is generally less than the rail voltage (VCC and VEE). Use DeltaVCC and DeltaVEE to specify the difference between the rail voltage and actual output voltage. For example, if VCC is +5V and the positive output is +4.5V, set DeltaVCC to 0.5V.
5. This opamp is a nonlinear model. If your circuit cannot achieve convergence using this model, use the OpAmpIdeal linear model.
6. The relationship between input and output voltages is given in the equation:

$$I_m \times \tanh(V_{in}/I_m) = V_{out}/A_0 - 10 \times (V_{clip} - V_{out}) + d/dt (V_{out} \times \text{Tau1}/A_0)$$
 where
 A_0 is open loop DC gain
 $V_{clip} = V_{out}$ as long as it is not limiting
 $I_m = \text{SlewRate} \times \text{Tau1}/A_0$
 $\text{Tau1} = A_0/2/\pi/\text{BW}$ when Pole1=0, otherwise $\text{Tau1} = 1/2/\pi/\text{BW}$

OpAmpIdeal (Ideal Operational Amplifier)

Symbol

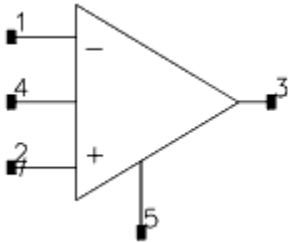

Available in ADS

Parameters

Name	Description	Units	Default
Gain	Complex Voltage Gain, use $x + j \times y$, polar(x,y), dbpolar(x,y)	None	100000

Z1	Input impedance, inverting terminal		
Z2	Input impedance, non-inverting terminal		
Z3	Output impedance		
Z4	Leakage impedance, inverting to non-inverting terminal		
Freq3db	Frequency at which gain magnitude is down by 3dB		
Delay	Time delay associated with gain	sec	0

Range of Usage

by default:

$$Z1 = \infty$$

$$Z2 = \infty$$

$$Z3 = 0$$

$$Z4 = \infty$$

$$\text{Freq3db} = \infty$$

Notes/Equations

$$1. \quad V_s = (V^+ - V^-) \text{Gain} \times \frac{e^{-j2\pi F \text{Delay}}}{1 + j \frac{F}{\text{Freq 3dB}}}$$

$$V_s = (V^+ - V^-) \text{Gain} (\text{for } f=0)$$

where F is the simulation frequency

1. OpAmpIdeal is a noiseless component.
2. The recommendation is to use a Gain value no greater than 1e10, or 200 dB for practical purposes.

Equivalent Circuit

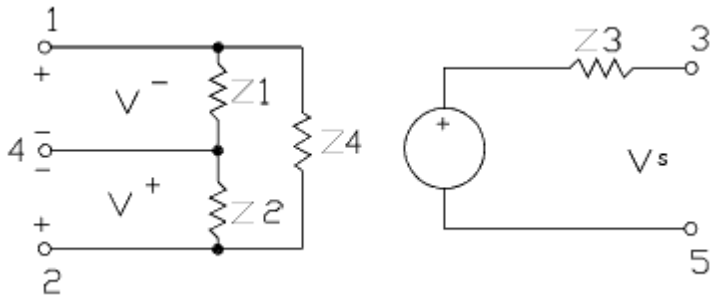

VMult (Voltage Multiplier)

Symbol

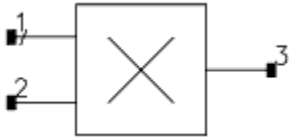

Available in ADS

Parameters

Name	Description	Units	Default
R1	Reference resistance for port 1	Ohm	50
R2	Reference resistance for port 2	Ohm	50
R3	Reference resistance for port 3	Ohm	50
L31	Loss in dB, pin 1 to pin 3; for linear analysis only	dB	0
L32	Loss in dB, pin 2 to pin 3;	dB	0

	for linear analysis only		
Linear	Use linear analysis mode: yes or no	None	no

Notes/Equations

1. VMult uses reference input and output impedances. Its output voltage is equal to the product of its two input voltages.

2. If Linear is set to yes,

$$V_3 = \frac{A_{31}V_1 + A_{32}V_2}{R_3}$$

A31 and A32 are the L31 and L32 losses converted from dB to regular values.

If Linear is set to no, V3 is formed from V1 and V2 through an ideal mixing process; for information on this process refer to the Ideal Mixer in the SDD Examples section in Chapter 5 in the User-Defined Models manual.

Filters for System Models

Introduction

The Filters - < filter type > and System - < device type > palettes contain two fundamentally different types of behavioral system models.

Filters , System - Amps & Mixers , and System - Mod/Demod can be classified as tops-down system models that support a tops-down system design flow where model behaviors are characterized by a small number of independent parameters such as frequency, power and load. They are often referred to as parameter-based behavioral models . System - Data Models can be classified as bottoms-up system models that support a bottoms-up verification flow where model behaviors are extracted from a simulation (or measurement) of a transistor-level circuit. They are often referred to as data-based behavioral models .

The parameter-based behavioral models typically provide superior speed relative to the data-based behavioral models with both of these being vastly superior to a brute-force transistor-level simulation.

The data-based behavioral models typically provide superior accuracy relative to the parameter-based behavioral models as they capture actual behaviors of implemented circuit components and not just design specifications.

The differences between parameter - and data-based behavioral models justify a palette emphasis on flow (all data-based behavioral models grouped together) rather than functionality (all amplifiers, mixers, modulators,

demodulators etc. grouped together).

The use model for parameter-based behavioral models is to simply set a series of parameters prior to using the model. The use model for data-based behavioral models is described in Chapter 8, System Data Models.

Filter Categories

The filter component libraries contains filters in eight response categories: Butterworth, Chebyshev, Elliptic, Gaussian, Bessel-Thompson, Raised-Cosine, Pole-Zero, and Polynomial. Lowpass, highpass, bandpass, and bandstop filters are available in each category.

Butterworth, Chebyshev, and Elliptic filters have good selectivity but poor group delay flatness; Bessel-Thompson and Gaussian filters have good delay flatness but poor selectivity. Raised-Cosine filters are uni-directional ideal Nyquist filters for bandlimiting digital signals. Pole-Zero and Polynomial filters allow users to define arbitrary response shapes.

Except for the Raised-Cosine category, the filter S-parameters are calculated based on standard filter synthesis theory [1]. S 21 and S 12 include losses specified by unloaded quality factor (Q_u) and insertion loss IL, where applicable. The assumption is made that filter pole predistortion is used to preserve the specified frequency response in the presence of losses [2]. However, S 11 and S 22 neglect losses, an approximation that causes little error for realizable filters.

The basic nature of the response of a lowpass, highpass, bandpass, and bandstop filter is illustrated below. The illustrations include certain filter parameter definitions: f_{pass} , f_{stop} , A_{pass} , and A_{stop} for lowpass/highpass filters, and f_{center} , BW_{pass} , BW_{stop} , A_{pass} , and A_{stop} for bandpass/bandstop filters. (Note that all filters do not have all of these parameters.)

In addition to these filter parameters, Gaussian and Bessel filters (XXX_Gaussian and XXX_Bessel (XXX = LPF, HPF, BPF, or BSF)) have a group delay parameter GD_{pass} . This parameter is motivated by the fact that a signal experiences a delay when passing through a filter. Calculated as the negative of the derivative of the phase response with respect to frequency, this delay (the group delay) will be frequency dependent for filters with a non-linear phase response. In other words, the group delay at a given frequency specifies the delay experienced by a group of sinusoidal components all having frequencies within a narrow interval around that frequency. A filter whose time-domain impulse response is symmetric around $t=0$ must be subjected to a certain finite shift (the group delay) in order to maintain (at least some resemblance of) causality when a transient simulator truncates its impulse response below zero. Different time-frequency characteristics for different filters can lead to different requirements for this group delay.

For LPF_Bessel and LPF_Gaussian, the group delay parameter GD_{pass} is defined as the group delay at the passband edge frequency relative to that at zero frequency (this is illustrated below). For highpass, bandpass, or bandstop filters, the definition is the same except that the group delay at infinity (highpass) or at the center frequency (bandpass, bandstop) is used as the reference. GD_{pass} cannot drop below zero and cannot exceed one; its default value is 0.9. The group delay value has a significant effect on filter order and therefore filter rejection. Larger GD_{pass} values will result in longer delays and larger filter orders; smaller GD_{pass} values will result in smaller delays and smaller filter orders. If your Gaussian or Bessel filter provides less out-of-band rejection than you expect, try

increasing the GD pass parameter.

There are two ways of dealing with filter order, N:

- Leave the filter order at zero and specify the parameters characterizing the behavior of the filter, per the illustrations below. Given these specifications, the program will calculate and report filter order N which meets these specifications. Because N must be an integer, the calculated order N exceeds the specifications in most cases. N is capped at the upper value of 15. For Chebyshev filters, the calculated filter order N must be an odd number to ensure filter symmetry.
- Alternatively, specify filter order N explicitly. If a non-zero N is specified, it will overwrite the filter specifications. The filter response is simply calculated based on the specified order N. As above, N must be an integer and will be capped at 15. And, N must be odd for Chebyshev filters.

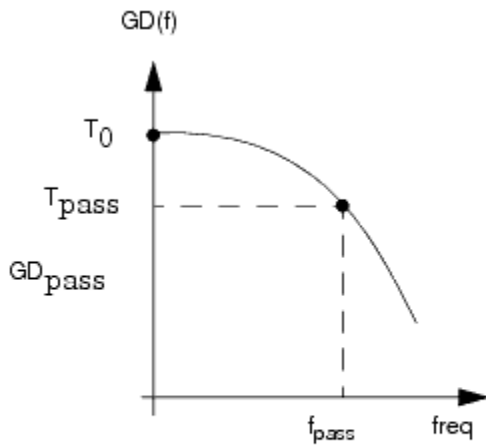

where
 $GD_{\text{pass}} = T_{\text{pass}}/T_0$

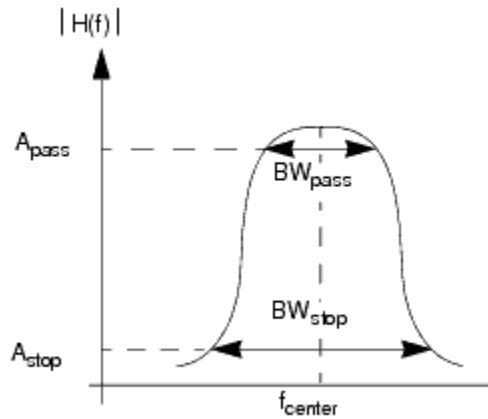
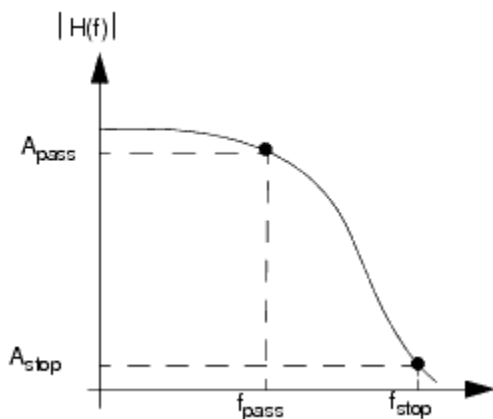

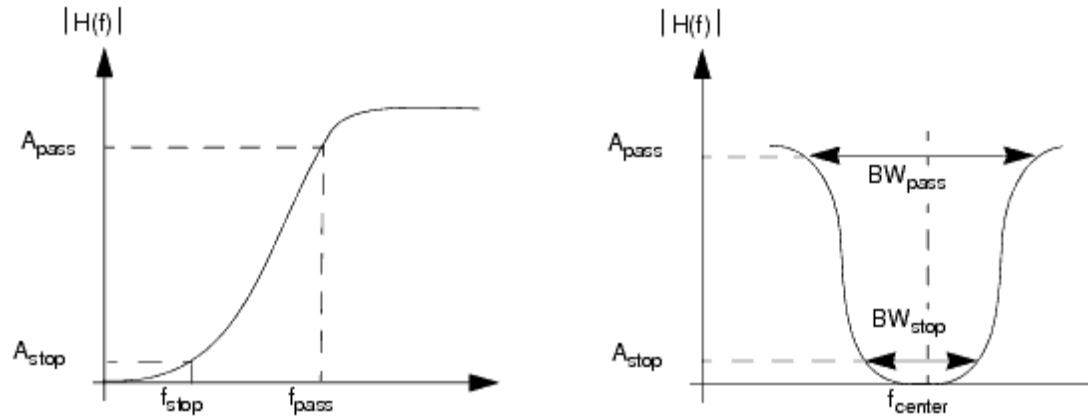

Lowpass Filter Behavior at DC

At DC, a lowpass filter appears to reduce to a wire. During DC analysis, one would therefore intuitively expect the S-matrix of a lowpass filter to reduce to $S_{11}=S_{22}=1$ and $S_{12}=S_{21}=0$. Also, one would intuitively expect the input and output voltages and currents to fulfill $v_2=v_1$ and $i_2=i_1$. For $Z_1=Z_2$, both these expectations are met. However, if Z_1 and Z_2 are unequal, there is simply no way to mathematically realize a meaningful filter that meets both expectations. If it meets the expectations in the S-domain, it won't for voltages and currents and vice versa.

The ADS lowpass filters are implemented in the S-domain, not the voltage/current-domain. At DC, the lowpass filters therefore reduce to a perfect $[1 \ 0; 0 \ 1]$ S-matrix regardless of the choice of reference impedance. The output voltage and current, however, are given by $v_2=\sqrt{Z_2/Z_1} \times v_1$ and $i_2=\sqrt{Z_1/Z_2} \times i_1$. This, as pointed out previously, reduces to $v_2=v_1$ and $i_2=i_1$ only for $Z_1=Z_2$. These relations can easily be derived from power conservation and can also be found from more rigorous S-parameter analysis.

References

1. A. I. Zverev, Handbook of Filter Synthesis , John Wiley and Sons, New York, 1967.
2. H. J. Blinchikoff and A. I. Zverev, Filtering in the Time and Frequency Domains , John Wiley and Sons, New York, 1976.
3. Kamilo Feher, Digital Communications: Microwave Applications , Prentice-Hall, Englewood Cliffs, N.J., 1981.
4. John G. Proakis, Digital Communications , McGraw-Hill, 1989.

BPF_Bessel (Bandpass Filter, Bessel-Thompson)

Symbol

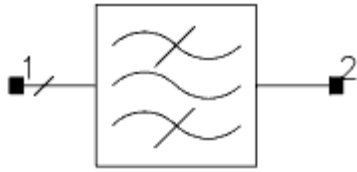

Available in ADS and RFDE

Parameters

Name	Description	Units	Default
Fcenter	Passband center frequency	GHz	1.5
BWpass	Passband edge-to-edge width	GHz	1.0
Apass	Attenuation at stopband edges	dB	3
GDpass	Group delay rolloff at passband edge, $0 < GDpass < 1$	None	0.9
StopType	Stopband input impedance type: OPEN or SHORT	None	open
MaxRej	Maximum rejection level	dB	None
N	Filter Order (if $N > 0$, it overwrites GDpass)	None	0
IL	Passband insertion loss	dB	0
Qu	Unloaded quality factor for resonators, default setting is an infinite Qu and expresses a dissipationless resonant circuit.	None	1e308
Z1	Input port reference impedance	Ohm	50
Z2	Output port reference impedance	Ohm	50
Temp	Temperature	°C	None

Range of Usage

$BW_{pass} < F_{center}$
 $0.01 \leq A_{pass} \leq 3.0$
 $0 < GD_{pass} < 1$
 $1 \leq N \leq 15$
 $Q_u \geq 1$

Notes/Equations

1. Refer to [Filter Categories](#).
2. This component has no default artwork associated with it.

BPF_Butterworth (Bandpass Filter, Butterworth)

Symbol

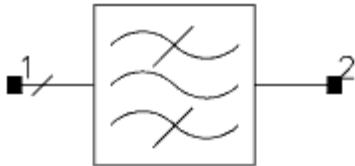

Available in ADS and RFDE

Parameters

Name	Description	Units	Default
Fcenter	Passband center frequency	GHz	1.5
BWpass	Passband edge-to-edge width	GHz	1.0
Apass	Attenuation at stopband	dB	3

Advanced Design System 2008

	edges		
BWstop	Stopband edge-to-edge width	GHz	1.2
Astop	Attenuation at stopband edges	dB	20
StopType	Stopband input impedance type: OPEN or SHORT	None	open
MaxRej	Maximum rejection level	dB	None
N	Filter Order (if N > 0, it overwrites GDpass)	None	0
IL	Passband insertion loss	dB	0
Qu	Unloaded quality factor for resonators, default setting is an infinite Qu and expresses a dissipationless resonant circuit.	None	1e308
Z1	Input port reference impedance	Ohm	50
Z2	Output port reference impedance	Ohm	50
Temp	Temperature	°C	None

Range of Usage

$1 \leq N \leq 15$
 $BW_{pass} < F_{center}$
 $0.01 \leq A_{pass} \leq 3.0$
 $Q_u \geq 1$

Notes/Equations

1. Refer to [Filter Categories](#).
2. This component has no default artwork associated with it.

BPF_Chebyshev (Bandpass Filter, Chebyshev)

Symbol

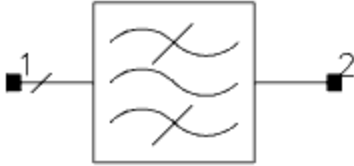

Available in ADS and RFDE

Parameters

Name	Description	Units	Default
Fcenter	Passband center frequency	GHz	1.5
BWpass	Passband edge-to-edge width	GHz	1.0
Apass	Attenuation at stopband edges	dB	1
Ripple	Passband ripple	dB	1
BWstop	width measured from lower to upper stopband edges	GHz	1.2
Astop	attenuation at stopband edges	dB	20
StopType	Stopband input impedance type: OPEN or SHORT	None	open
MaxRej	Maximum rejection level	dB	None
N	Filter Order (if N > 0, it overwrites GDpass)	None	0
IL	Passband insertion loss	dB	0
Qu	Unloaded quality factor for resonators, default setting is an infinite Qu and expresses a dissipationless	None	1e308

	resonant circuit.		
Z1	Input port reference impedance	Ohm	50
Z2	Output port reference impedance	Ohm	50
Temp	Temperature	°C	None

Range of Usage

$BW_{pass} < F_{center}$
 $0.01 \leq \text{Ripple} \leq 3.0$
 $1 \leq N \leq 15$
 $Q_u \geq 1$

Notes/Equations

1. Refer to [Filter Categories](#).
2. This component has no default artwork associated with it.

BPF_Elliptic (Bandpass Filter, Elliptic)

Symbol

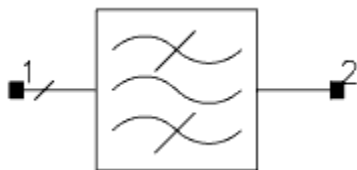

Available in ADS and RFDE

Advanced Design System 2008

Parameters

Name	Description	Units	Default
Fcenter	Passband center frequency	GHz	1.5
BWpass	Passband edge-to-edge width	GHz	1.0
Ripple	Passband ripple	dB	1
BWstop	Stopband edge-to-edge width	GHz	1.2
Astop	Attenuation at stopband edges	dB	20
StopType	Stopband input impedance type: OPEN or SHORT	None	open
MaxRej	Maximum rejection level	dB	None
N	Filter Order (if N > 0, it overwrites GDpass)	None	0
IL	Passband insertion loss	dB	0
Qu	Unloaded quality factor for resonators, default setting is an infinite Qu and expresses a dissipationless resonant circuit.	None	1e308
Z1	Input port reference impedance	Ohm	50
Z2	Output port reference impedance	Ohm	50
Temp	Temperature	°C	None

Range of Usage

$BW_{pass} < F_{center}$
 $0.01 \leq Ripple \leq 3.0$
 $A_{stop} > 0$
 $1 \leq N \leq 15$

Notes/Equations

1. Refer to [Filter Categories](#).
2. This component has no default artwork associated with it.

BPF_Gaussian (Bandpass Filter, Gaussian)

Symbol

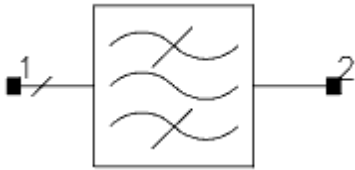

Available in ADS and RFDE

Parameters

Name	Description	Units	Default
Fcenter	Passband center frequency	GHz	1.5
BWpass	Passband edge-to-edge width	GHz	1.0
Apass	Attenuation at stopband edges	dB	3
GDpass	Group delay rolloff at passband edge, $0 < \text{GDpass} < 1$	None	0.9
StopType	Stopband input impedance type: OPEN or SHORT	None	open
MaxRej	Maximum rejection level	dB	None
N	Filter Order (if $N > 0$, it overwrites GDpass)	None	0
IL	Passband insertion loss	dB	0

Qu	Unloaded quality factor for resonators, default setting is an infinite Qu and expresses a dissipationless resonant circuit	None	1e308
Z1	Input port reference impedance	Ohm	50
Z2	Output port reference impedance	Ohm	50
Temp	Temperature	°C	None

Range of Usage

$BW_{pass} < F_{center}$
 $0.01 \leq A_{pass} \leq 3.0$
 $0 < GD_{pass} < 1$
 $1 \leq N \leq 15$
 $Q_u \geq 1$

Notes/Equations

1. Refer to [Filter Categories](#).
2. This component has no default artwork associated with it.

BPF_PoleZero (Bandpass Filter, Pole Zero)

Symbol



Available in ADS and RFDE

Parameters

Name	Description	Units	Default
Numerator	List of numerator coefficients	None	list(1)
Denominator	List of denominator coefficients	None	list(1,1.4,1)
Gain	Gain factor	None	1.0
Fcenter	Passband edge frequency	GHz	1
BWpass	Passband edge-to-edge width	GHz	1.0
StopType	Stopband input impedance type: OPEN or SHORT	None	open
Z1	Input port reference impedance	Ohm	50
Z2	Output port reference impedance	Ohm	50

Notes/Equations

1. This is an S-domain filter.
2. Denominator and Numerator are a list of polynomial coefficients.
The transfer function for the filter is:

$$S_{21} = Gain \left(\frac{N_0 + (N_1 \times S) + (N_2 \times S^2) \dots}{D_0 + (D_1 \times S) + (D_2 \times S^2) \dots} \right)$$

where

$$S = j \times (\text{Freq}/F_o - F_o/\text{Freq}) / (F_{\text{high}}/F_o - F_o/F_{\text{high}})$$

and

Freq is the analysis frequency

$$F_{\text{high}} = F_{\text{center}} + 0.5 \times \text{BW}_{\text{pass}}$$

$$F_o = \sqrt{(F_{\text{center}} - 0.5 \times \text{BW}_{\text{pass}}) \times (F_{\text{center}} + 0.5 \times \text{BW}_{\text{pass}})}$$

3. The following example demonstrates interpretation of simulation results with this component. From the user-specified poles/zeros, we derive:

$$S21_{\text{Lowpass_Prototype}} = \text{Gain} * [(s-Z1)*...*(s-Zn)] / [(s-P1)*...*(s-Pm)]$$

We then check to see if S21_Lowpass_Prototype is > 1. If yes, we scale S21 by a another factor to make sure S21_Max ≤ 1 . We then derive S11 (S22) from the following formula:

$$S11^2 + S21^2 = 1$$

In this example, when Gain is set > 0.471151 , then S11 is derived as what you will expect. If Gain in your example is < 0.471151 , then S11 derived from the preceding equation, will be much higher than what you will expect. In this situation, set Gain to be 0.1 so that S21 has a lot of insertion loss. But we assumed there is no insertion loss in deriving S11.

There are other alternatives:

- Use S2P_Eqn so that you can define the S21 and S11 polynomials however you want. You can define this as follows:
 $s = j\omega$, $S21 = \text{Gain} * (s - Z1) * \dots * (s - Zn) / (s - P1) * \dots * (s - Pn)$, $S11 = \langle \text{your choice} \rangle$
- Use BPF_Pole_Zero to model a lossless BPF, then use an attenuator to add insertion loss.

BPF_Polynomial (Bandpass Filter, Polynomial)

Symbol



Available in ADS and RFDE

Parameters

Name	Description	Units	Default
Numerator	List of numerator coefficients	None	list(1)
Denominator	List of denominator coefficients	None	list(1,1.4,1)
Gain	Gain factor	None	1.0
Fcenter	Passband center frequency	GHz	1
BWpass	Passband edge-to-edge width	GHz	1.0

StopType	Stopband input impedance type: OPEN or SHORT	None	open
Z1	Input port reference impedance	Ohm	50
Z2	Output port reference impedance	Ohm	50

Notes/Equations

1. This is an S-domain filter.
2. Denominator and Numerator are a list of polynomial coefficients.
The transfer function for the filter is:

$$S_{21} = Gain \left(\frac{N_0 + (N_1 \times S) + (N_2 \times S^2) \dots}{D_0 + (D_1 \times S) + (D_2 \times S^2) \dots} \right)$$

where

$S = j \times (\text{Freq}/F_o - F_o/\text{Freq}) / (F_{\text{high}}/F_o - F_o/F_{\text{high}})$

and

Freq is the analysis frequency

$F_{\text{high}} = F_{\text{center}} + 0.5 \times \text{BW}_{\text{pass}}$

$F_o = \text{sqrt}((F_{\text{center}} - 0.5 \times \text{BW}_{\text{pass}}) \times (F_{\text{center}} + 0.5 \times \text{BW}_{\text{pass}}))$

BPF_RaisedCos (Bandpass Filter, Raised-Cosine)

Symbol

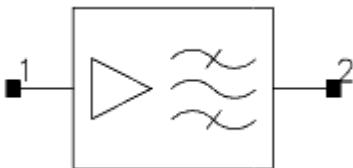

Available in ADS and RFDE

Advanced Design System 2008

Parameters

Name	Description	Units	Default
Alpha	Rolloff factor defining filter's excess bandwidth, $0 \leq \text{Alpha} \leq 1$	None	0.35
Fcenter	Passband center frequency	GHz	1.5
SymbolRate	Digital symbol rate defining filter bandwidth	kHz	24.3
DelaySymbols	Number of symbols delayed by filter	None	5
Exponent	Exponent Factor ($0 \leq \text{Exponent} \leq 1$), to provide for Root Raised-Cosine filter	None	0.5
DutyCycle	Pulse duty cycle in percent, used for sinc(x) correction	None	0
SincE	Flag to include the Exponent factor on the sinc(x) correction: yes or no	None	no
Gain	Gain factor	None	1.0
Zout	Output impedance	Ohm	50
WindowType	Window type applied to impulse response. 0=None, 1=Hann, 2=Hamming	None	0
ImpMaxFreq	Maximum frequency to consider when calculating impulse response		
ImpDeltaFreq	Impulse sample spacing in frequency		
ImpMaxPts	Maximum number of points in impulse response	None	None
Other	Output string to netlist	None	None

Range of Usage

$0 \leq \text{Alpha} \leq 1$
 $\text{DelaySymbols} \geq 1$

- 0 ≤ Exponent ≤ 1
 0 ≤ DutyCycle ≤ 100

Notes/Equations

1. Refer to [Filter Categories](#).
2. This filter is unidirectional; input impedance is infinite; output impedance is specified by Zout.
3. Voltage gain is described by the following function.

$$\frac{V_{out}}{V_{in}} = \frac{Gain \times G_{filt}}{G_{comp}} e^{-j2\pi frequency \left(\frac{DelaySymbols}{SymbolRate} \right)}$$

where

G filt	= 1.0 for Freq ≤ 0.5 × (1 – Alpha) × SymbolRate	
	= 0.0 for Freq ≥ 0.5 × (1 + Alpha) × SymbolRate	
	= [0.5 × (1 – sin[π × (Freq – SymbolRate /2)]/	
G comp	= 1.0	if DutyCycle =0
	= [0.01 × DutyCycle × sinc(x)] Exponent	if SincE = YES
	= [0.01 × DutyCycle × sinc(x)]	if SincE = NO
Freq	= abs (Fcenter – frequency)	
sinc(x)	= sin(x)/x	
x	= 0.01 × DutyCycle × π × Freq / SymbolRate	

4. While Exponent can be any value, the standard value is 1.0 for the ideal raised-cosine filter response or 0.5 to simulate the root raised-cosine filter response when present at both the receiving and transmitting channels.
5. In steady-state frequency-domain analyses, the ideal frequency-domain response described previously is used; however, this ideal response has an infinite duration impulse response that must be approximated for time-domain simulations in either Transient or Circuit Envelope. If DelaySymbols is set too small, then the impulse response will be severely truncated and will not accurately reflect the ideal frequency response. Using a Hanning window (WindowType=1) a DelaySymbols parameter of 15 should result in equivalent frequency domain sidelobes of –90dBc or smaller.
6. Accuracy of this model in Transient or Circuit Envelope can be further controlled through the ImpMaxFreq, ImpDeltaFreq, and ImpMaxPts parameters.
7. The filter can include gain equalization to compensate for duty cycle roll-off. If DutyCycle = 0.0, then no compensation will be applied. If SincE=YES, Exponent will be applied to the gain compensation term G comp . The Exponent term is always present in the G filt term.
8. This component has no default artwork associated with it.

BSF_Bessel (Bandstop Filter, Bessel-Thompson)

Symbol

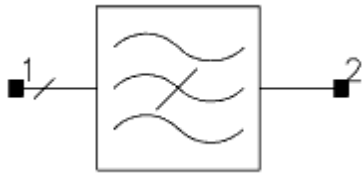

Available in ADS and RFDE

Parameters

Name	Description	Units	Default
Fcenter	Stopband center frequency	GHz	1.5
BWpass	Passband edge-to-edge width	GHz	1.0
Apass	Attenuation at passband edges	dB	3
GDpass	Group delay rolloff at passband edge, $0 < GDpass < 1$	None	0.9
StopType	Stopband input impedance type: OPEN or SHORT	None	open
MaxRej	Maximum rejection level	dB	None
N	Filter order (if $N > 0$, it overwrites GDpass); if not given, it is calculated based on BWpass, Apass and GDpass	None	0

IL	Passband insertion loss	dB	0
Qu	Unloaded quality factor for resonators, default setting is an infinite Qu and expresses a dissipationless resonant circuit.	None	1e308
Z1	Input port reference impedance	Ohm	50
Z2	Output port reference impedance	Ohm	50
Temp	Temperature	°C	None

Range of Usage

$BW_{pass} < F_{center}$
 $0.01 \leq A_{pass} \leq 3.0$
 $0 < GD_{pass} < 1$
 $1 \leq N \leq 15$

Notes/Equations

1. Refer to [Filter Categories](#).
2. This component has no default artwork associated with it.

BSF_Butterworth (Bandstop Filter, Butterworth)

Symbol

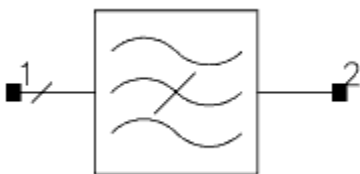

Advanced Design System 2008

Available in ADS and RFDE

Parameters

Name	Description	Units	Default
Fcenter	Stopband center frequency	GHz	1.5
BWstop	Stopband edge-to-edge width	GHz	1.0
Astop	Attenuation at stopband edges	dB	20
BWpass	Passband edge-to-edge width	GHz	1.2
Apass	Attenuation at passband edges	dB	3
StopType	Stopband input impedance type: OPEN or SHORT	None	open
MaxRej	Maximum rejection level	dB	None
N	Filter order (if $N > 0$, it overwrites BWstop and Astop)); if not given, it is calculated based on BWpass, Apass and GDpass	None	0
IL	Passband insertion loss	dB	0
Qu	Unloaded quality factor for resonators, default setting is an infinite Qu and expresses a dissipationless resonant circuit.	None	1e308
Z1	Input port reference impedance	Ohm	50
Z2	Output port reference impedance	Ohm	50
Temp	Temperature	°C	None

Range of Usage

$BW_{pass} < F_{center}$
 $0.01 \leq A_{pass} \leq 3.0$

$1 \leq N \leq 15$

Notes/Equations

1. Refer to [Filter Categories](#).
2. This component has no default artwork associated with it.

BSF_Chebyshev (Bandstop Filter, Chebyshev)

Symbol

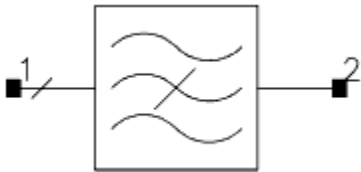

Available in ADS and RFDE

Parameters

Name	Description	Units	Default
Fcenter	Stopband center frequency	GHz	1.5
BWstop	Stopband edge-to-edge width	GHz	1.0
Astop	Attenuation at stopband edges	dB	20
Ripple	Stopband ripple	dB	1
BWpass	Passband edge-to-edge width	GHz	1.2
Apass	Attenuation at passband	dB	1

Advanced Design System 2008

	edges		
StopType	Stopband input impedance type: OPEN or SHORT	None	open
MaxRej	Maximum rejection level	dB	None
N	Filter order (if $N > 0$, it overwrites BWstop and Astop)); if not given, it is calculated based on BWpass, Apass and GDpass	None	0
IL	Passband insertion loss	dB	0
Qu	Unloaded quality factor for resonators, default setting is an infinite Qu and expresses a dissipationless resonant circuit.	None	1e308
Z1	Input port reference impedance	Ohm	50
Z2	Output port reference impedance	Ohm	50
Temp	Temperature	°C	None

Range of Usage

$BW_{pass} < F_{center}$
 $0.01 \leq \text{Ripple} \leq 3.0$
 $1 \leq N \leq 15$

Notes/Equations

1. Refer to [Filter Categories](#).
2. This component has no default artwork associated with it.

BSF_Elliptic (Bandstop Filter, Elliptic)

Symbol

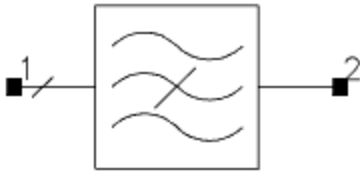

Available in ADS and RFDE

Parameters

Name	Description	Units	Default
Fcenter	Stopband center frequency	GHz	1.5
BWstop	Stopband edge-to-edge width	GHz	1.0
Astop	Attenuation at stopband edges	dB	20
Ripple	Stopband ripple	dB	1
BWpass	Passband edge-to-edge width	GHz	1.2
Apass	Attenuation at passband edges	dB	1
StopType	Stopband input impedance type: OPEN or SHORT	None	open
MaxRej	Maximum rejection level	dB	None
N	Filter order (if N > 0, it overwrites BWstop and Astop)); if not given, it is calculated based on BWpass, Apass and GDpass	None	0
IL	Passband insertion loss	dB	0
Qu	Unloaded quality factor for resonators, default setting is an infinite Qu and expresses a dissipationless resonant circuit.	None	1e308
Z1	Input port reference	Ohm	50

	impedance		
Z2	Output port reference impedance	Ohm	50
Temp	Temperature	°C	None

Range of Usage

$BW_{pass} < F_{center}$
 $0.01 \leq \text{Ripple} \leq 3.0$
 $1 \leq N \leq 15$

Notes/Equations

1. Refer to [Filter Categories](#).
2. This component has no default artwork associated with it.

BSF_Gaussian (Bandstop Filter, Gaussian)

Symbol

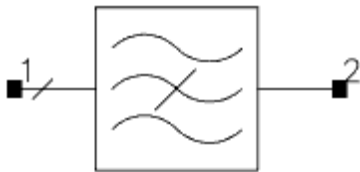

Available in ADS and RFDE

Parameters

Advanced Design System 2008

Name	Description	Units	Default
Fcenter	Stopband center frequency	GHz	1.5
BWpass	Passband edge-to-edge width	GHz	1.0
Apass	Attenuation at passband edges	dB	3
GDpass	Group delay rolloff at passband edge, $0 < \text{GDpass} < 1$	None	0.9
StopType	Stopband input impedance type: OPEN or SHORT	None	open
MaxRej	Maximum rejection level	dB	None
N	Filter order (if $N > 0$, it overwrites BWstop and Astop)); if not given, it is calculated based on BWpass, Apass and GDpass	None	0
IL	Passband insertion loss	dB	0
Qu	Unloaded quality factor for resonators, default setting is an infinite Qu and expresses a dissipationless resonant circuit.	None	1e308
Z1	Input port reference impedance	Ohm	50
Z2	Output port reference impedance	Ohm	50
Temp	Temperature	°C	None

Range of Usage

$\text{BWpass} < \text{Fcenter}$
 $0.01 \leq \text{Apass} \leq 3.0$
 $0 < \text{GDpass} < 1$
 $1 \leq N \leq 15$

Notes/Equations

1. Refer to [Filter Categories](#).
2. This component has no default artwork associated with it.

BSF_PoleZero (Bandstop Filter, Pole Zero)

Symbol



Available in ADS and RFDE

Parameters

Name	Description	Units	Default
Numerator	List of numerator coefficients	None	list(1)
Denominator	List of denominator coefficients	None	list(1,1.4,1)
Gain	Gain factor	None	1.0
Fcenter	Passband edge frequency	GHz	1
BWpass	Passband edge-to-edge width	GHz	1.0
StopType	Stopband input impedance type: OPEN or SHORT	None	open
Z1	Input port reference impedance	Ohm	50
Z2	Output port reference impedance	Ohm	50

Notes/Equations

1. This is an S-domain filter.
2. Denominator and Numerator are lists of polynomial coefficients.

The transfer function for the filter is:

$$S_{21} = Gain \frac{(N_0 + (N_1 \times S) + (N_2 \times S^2) \dots)}{(D_0 + (D_1 \times S) + (D_2 \times S^2) \dots)}$$

where

$$S = -j \times (F_o / F_{low} - F_{low} / F_o) / (Freq / F_o - F_o / Freq)$$

and

Freq is the analysis frequency

$$F_{low} = F_{center} - 0.5 \times BW_{pass}$$

$$F_o = \sqrt{(F_{center} - 0.5 \times BW_{pass}) \times F_{center} + 0.5 \times BW_{pass}}$$

At least one Denominator coefficient must be supplied.

BSF_Polynomial (Bandstop Filter, Polynomial)

Symbol



Available in ADS and RFDE

Parameters

Name	Description	Units	Default
Numerator	List of numerator coefficients	None	list(1)
Denominator	List of denominator coefficients	None	list(1,1.4,1)

Gain	Gain factor	None	1.0
Fcenter	Passband Edge Frequency	GHz	1
BWpass	Passband Edge-to-Edge Width	GHz	1.0
StopType	Stopband input impedance type: OPEN or SHORT	None	open
Z1	Input port reference impedance	Ohm	50
Z2	Output port reference impedance	Ohm	50

Notes/Equations

1. This is an S-domain filter.
2. Denominator and Numerator are lists of polynomial coefficients.
The transfer function for the filter is:

$$S_{21} = Gain \left(\frac{N_0 + (N_1 \times S) + (N_2 \times S^2) \dots}{D_0 + (D_1 \times S) + (D_2 \times S^2) \dots} \right)$$

where

$$S = -j \times (F_o / F_{low} - F_{low} / F_o) / (Freq / F_o - F_o / Freq)$$

and

Freq is the analysis frequency

$$F_{low} = F_{center} - 0.5 \times BW_{pass}$$

$$F_o = \sqrt{(F_{center} - 0.5 \times BW_{pass}) \times F_{center} + 0.5 \times BW_{pass}}$$

At least one Denominator coefficient must be supplied.

BSF_RaisedCos (Bandstop Filter, Raised-Cosine)

Symbol

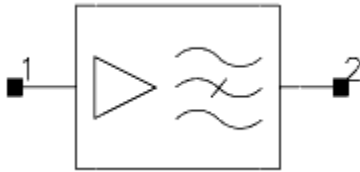

Available in ADS and RFDE

Parameters

Name	Description	Units	Default
Alpha	Rolloff factor defining filter excess bandwidth, $0 \leq \text{Alpha} \leq 1$	None	0.35
Fcenter	Passband center frequency	GHz	1.5
SymbolRate	Digital symbol rate defining filter bandwidth	kHz	24.3
DelaySymbols	Number of symbols delayed by filter	None	5
Exponent	Exponent factor ($0 \leq \text{Exponent} \leq 1$), to provide for Root Raised-Cosine filter	None	0.5
DutyCycle	Pulse duty cycle in percent, used for sinc(x) correction	None	0
SincE	Flag to include the Exponent factor on the sinc(x) correction: yes or no	None	no
Gain	Gain factor	None	1.0
Zout	Output impedance	Ohm	50
WindowType	Window type applied to impulse response: 0=None, 1=Hann, 2=Hamming	None	0
ImpMaxFreq	Maximum frequency to consider when calculating impulse response		

Advanced Design System 2008

ImpDeltaFreq	Frequency sample spacing when calculating impulse response		
ImpMaxPts	Maximum number of points in impulse response	None	None
Other	Output string to netlist	None	None

Range of Usage

- $0 \leq \text{Alpha} \leq 1$
 $\text{DelaySymbols} \geq 1$
 $0 \leq \text{Exponent} \leq 1$
 $0 \leq \text{DutyCycle} \leq 100$

Notes/Equations

1. Refer to [Filter Categories](#).
2. This filter is unidirectional; input impedance is infinite; output impedance is specified by Zout.
3. Voltage gain is described by the following function.

$$\frac{V_{out}}{V_{in}} = \frac{Gain \times G_{filt}}{G_{comp}} e^{-j2\pi frequency \left(\frac{DelaySymbols}{SymbolRate} \right)}$$

G filt	= 0.0 for Freq $\leq 0.5 \times (1 - \text{Alpha}) \times \text{SymbolRate}$	
	= 1.0 for Freq $\geq 0.5 \times (1 + \text{Alpha}) \times \text{SymbolRate}$	
	= $[0.5 \times (1 + \sin[n \times (\text{Freq} - \text{SymbolRate} / 2)])]$	
G comp	= 1.0	if DutyCycle = 0
	= $[0.01 \times \text{DutyCycle} \times \text{sinc}(x)]$ Exponent	if SincE = YES
	= $[0.01 \times \text{DutyCycle} \times \text{sinc}(x)]$	if SincE = NO
Freq	= abs (Fcenter – frequency)	
sinc(x)	= sin(x)/x	
x	= $0.01 \times \text{DutyCycle} \times n \times \text{Freq} / \text{SymbolRate}$	

4. While Exponent can be any value, the standard value is 1.0 for the ideal raised-cosine filter response or 0.5 to

- simulate the root raised-cosine filter response when present at both the receiving and transmitting channels.
5. In steady-state frequency-domain analyses, the ideal frequency-domain response described previously is used; however, this ideal response has an infinite duration impulse response that must be approximated for time-domain simulations in either Transient or Circuit Envelope. If DelaySymbols is set too small, then the impulse response will be severely truncated and will not accurately reflect the ideal frequency response. Using a Hanning window (WindowType=1) a DelaySymbols value of 15 should result in equivalent frequency domain sidelobes of -90dBc or smaller.
 6. Accuracy of this model in Transient or Circuit Envelope can be further controlled through the ImpMaxFreq, ImpDeltaFreq, and ImpMaxPts parameters.
 7. The filter can include gain equalization to compensate for duty cycle roll-off. If DutyCycle = 0.0, then no compensation will be applied. If SincE=YES, Exponent will be applied to the gain compensation term, G comp . The Exponent term is always present in the G filt term.
 8. This component has no default artwork associated with it.

HPF_Bessel (Highpass Filter, Bessel-Thompson)

Symbol

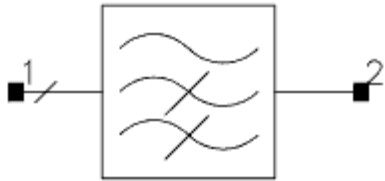

Available in ADS and RFDE

Parameters

Name	Description	Units	Default
Fpass	Passband edge frequency	GHz	1
Apass	Attenuation at passband edges	dB	3
GDpass	Group delay rolloff at passband edge, $0 < \text{GDpass} < 1$	None	0.9

Advanced Design System 2008

StopType	Stopband input impedance type: OPEN or SHORT	None	open
MaxRej	Maximum rejection level	dB	None
N	Filter order (if $N > 0$, it overwrites BWstop and Astop)); if not given, it is calculated based on BWpass, Apass and GDpass	None	0
IL	Passband insertion loss	dB	0
Qu	Unloaded quality factor for resonators, default setting is an infinite Qu and expresses a dissipationless resonant circuit.	None	1e308
Z1	Input port reference impedance	Ohm	50
Z2	Output port reference impedance	Ohm	50
Temp	Temperature	°C	None

Range of Usage

$F_{pass} > 0$
 $0.01 \leq A_{pass} \leq 3.0$
 $0 \leq GD_{pass} < 1$
 $1 \leq N \leq 15$

Notes/Equations

1. Refer to [Filter Categories](#).
2. This component has no default artwork associated with it.

HPF_Butterworth (Highpass Filter, Butterworth)

Symbol

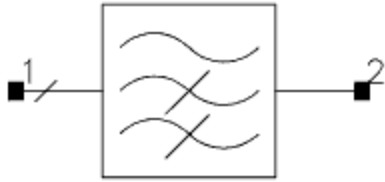

Available in ADS and RFDE

Parameters

Name	Description	Units	Default
Fpass	Passband edge frequency	GHz	1
Apass	Attenuation at passband edges	dB	3
Fstop	Stopband edge frequency	GHz	0.8
Astop	Attenuation at stopband edges	dB	20
StopType	Stopband input impedance type: OPEN or SHORT	None	open
MaxRej	Maximum rejection level	dB	None
N	Filter order (if $N > 0$, it overwrites BWstop and Astop)); if not given, it is calculated based on BWpass, Apass and GDpass	None	0
IL	Passband insertion loss	dB	0
Qu	Unloaded quality factor for resonators, default setting is an infinite Qu and expresses a dissipationless resonant circuit.	None	1e308
Z1	Input port reference impedance	Ohm	50
Z2	Output port reference impedance	Ohm	50

Temp	Temperature	°C	None
------	-------------	----	------

Range of Usage

$F_{pass} > 0$
 $0.01 \leq A_{pass} \leq 3.0$
 $1 \leq N \leq 15$

Notes/Equations

1. Refer to [Filter Categories](#).
2. This component has no default artwork associated with it.

HPF_Chebyshev (Highpass Filter, Chebyshev)

Symbol

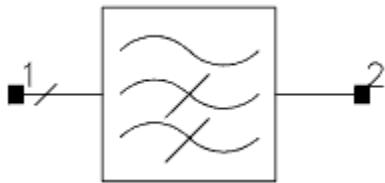

Available in ADS and RFDE

Parameters

Name	Description	Units	Default
Fpass	Passband edge frequency	GHz	1
Apass	Attenuation at passband	dB	1

Advanced Design System 2008

	edges		
Ripple	Stopband ripple	dB	1
Fstop	Stopband edge frequency	GHz	0.8
Astop	Attenuation at stopband edges	dB	20
StopType	Stopband input impedance type: OPEN or SHORT	None	open
MaxRej	Maximum rejection level	dB	None
N	Filter order (if $N > 0$, it overwrites BWstop and Astop)); if not given, it is calculated based on BWpass, Apass and GDpass	None	0
IL	Passband insertion loss	dB	0
Qu	Unloaded quality factor for resonators, default setting is an infinite Qu and expresses a dissipationless resonant circuit.	None	1e308
Z1	Input port reference impedance	Ohm	50
Z2	Output port reference impedance	Ohm	50
Temp	Temperature	°C	None

Range of Usage

$F_{pass} > 0$
 $0.01 \leq \text{Ripple} \leq 3.0$
 $1 \leq N \leq 15$

Notes/Equations

1. Refer to [Filter Categories](#).
2. This component has no default artwork associated with it.

HPF_Elliptic (Highpass Filter, Elliptic)

Symbol

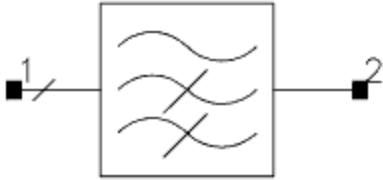

Available in ADS and RFDE

Parameters

Name	Description	Units	Default
Fpass	Passband edge frequency	GHz	1
Ripple	Stopband ripple	dB	1
Fstop	Stopband edge frequency	GHz	0.8
Astop	Attenuation at stopband edges	dB	20
StopType	Stopband input impedance type: OPEN or SHORT	None	open
MaxRej	Maximum rejection level	dB	None
N	Filter order (if $N > 0$, it overwrites BWstop and Astop)); if not given, it is calculated based on BWpass, Apass and GDpass	None	0
IL	Passband insertion loss	dB	0
Qu	Unloaded quality factor for resonators, default setting is an infinite Qu and expresses a dissipationless resonant circuit.	None	1e308
Z1	Input port reference impedance	Ohm	50

Z2	Output port reference impedance	Ohm	50
Temp	Temperature	°C	None

Range of Usage

$F_{pass} > 0$
 $0.01 \leq \text{Ripple} \leq 3.0$
 $A_{stop} > 0$
 $1 \leq N \leq 15$

Notes/Equations

1. Refer to [Filter Categories](#).
2. This component has no default artwork associated with it.

HPF_Gaussian (Highpass Filter, Gaussian)

Symbol

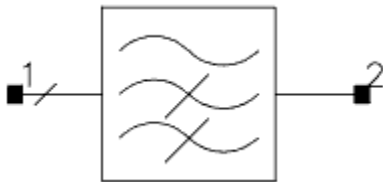

Available in ADS and RFDE

Parameters

Name	Description	Units	Default
------	-------------	-------	---------

Advanced Design System 2008

Fpass	Passband edge frequency	GHz	1
Apass	Attenuation at passband edges	dB	3
GDpass	Group delay rolloff at passband edge, $0 < \text{GDpass} < 1$	None	0.9
StopType	Stopband input impedance type: OPEN or SHORT	None	open
MaxRej	Maximum rejection level	dB	None
N	Filter order (if $N > 0$, it overwrites BWstop and Astop)); if not given, it is calculated based on BWpass, Apass and GDpass	None	0
IL	Passband insertion loss	dB	0
Qu	Unloaded quality factor for resonators, default setting is an infinite Qu and expresses a dissipationless resonant circuit.	None	1e308
Z1	Input port reference impedance	Ohm	50
Z2	Output port reference impedance	Ohm	50
Temp	Temperature	°C	None

Range of Usage

$F_{\text{pass}} > 0$
 $0.01 \leq A_{\text{pass}} \leq 3.0$
 $0 < \text{GDpass} < 1$
 $1 \leq N \leq 15$

Notes/Equations

1. Refer to [Filter Categories](#).
2. This component has no default artwork associated with it.

HPF_PoleZero (Highpass Filter, Pole Zero)

Symbol



Available in ADS and RFDE

Parameters

Name	Description	Units	Default
Numerator	List of numerator coefficients	None	list(1)
Denominator	List of denominator coefficients	None	list(1,1.4,1)
Gain	Gain factor	None	1.0
Fpass	Passband Edge Frequency	GHz	1
StopType	Stopband input impedance type: OPEN or SHORT	None	open
Z1	Input port reference impedance	Ohm	50
Z2	Output port reference impedance	Ohm	50

Notes/Equations

1. This is an S-domain filter.
2. Denominator and Numerator are a list of polynomial coefficients.

The transfer function for the filter is:

$$S_{21} = Gain \left(\frac{N_0 + (N_1 \times S) + (N_2 \times S^2) \dots}{D_0 + (D_1 \times S) + (D_2 \times S^2) \dots} \right)$$

where

$S = -j(F_{pass}/F_{req})$

and

Freq is the analysis frequency

HPF_Polynomial (Highpass Filter, Polynomial)

Symbol



Available in ADS and RFDE

Parameters

Name	Description	Units	Default
Numerator	List of numerator coefficients	None	list(1)
Denominator	List of denominator coefficients	None	list(1,1.4,1)
Gain	Gain factor	None	1.0
Fpass	Passband edge frequency	GHz	1
StopType	Stopband input impedance	None	open

	type: OPEN or SHORT		
Z1	Input port reference impedance	Ohm	50
Z2	Output port reference impedance	Ohm	50

Notes/Equations

1. This is an S-domain filter.
2. Denominator and Numerator are a list of polynomial coefficients.

The transfer function for the filter is:

$$S_{21} = Gain \left(\frac{N_0 + (N_1 \times S) + (N_2 \times S^2) \dots}{D_0 + (D_1 \times S) + (D_2 \times S^2) \dots} \right)$$

where

$S = -j(F_{pass}/Freq)$

and

Freq is the analysis frequency

HPF_RaisedCos (Highpass Filter, Raised-Cosine)

Symbol

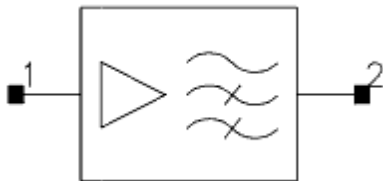

Available in ADS and RFDE

Parameters

Advanced Design System 2008

Name	Description	Units	Default
Alpha	Rolloff factor defining filter excess bandwidth, $0 \leq \text{Alpha} \leq 1$	None	0.35
SymbolRate	Digital symbol rate defining filter bandwidth	kHz	24.3
DelaySymbols	Number of symbols delayed by filter	None	5
Exponent	Exponent factor ($0 \leq \text{Exponent} \leq 1$), to provide for Root Raised-Cosine filter	None	0.5
DutyCycle	Pulse duty cycle in percent, used for sinc(x) correction	None	0
SincE	Flag to include the Exponent factor on the sinc(x) correction: yes or no	None	no
Gain	Gain factor	None	1.0
Zout	Output impedance	Ohm	50
WindowType	Window type applied to impulse response: 0=None, 1=Hann, 2=Hamming	None	0
ImpMaxFreq	Maximum frequency to consider when calculating impulse response		
ImpDeltaFreq	Frequency sample spacing when calculating impulse response		
ImpMaxPts	Maximum number of points in impulse response	None	None
Other	Output string to netlist	None	None

Range of Usage

$0 \leq \text{Alpha} \leq 1$

$\text{DelaySymbols} \geq 1$

$0 \leq \text{Exponent} \leq 1$

$0 \leq \text{DutyCycle} \leq 100$

Notes/Equations

1. Refer to [Filter Categories](#).
2. This filter is unidirectional; input impedance is infinite; output impedance is specified by Zout.
3. This filter is unidirectional; input impedance is infinite; output impedance is specified by Zout.
4. Voltage gain is described by the following function.

$$\frac{V_{out}}{V_{in}} = \frac{Gain \times G_{filt}}{G_{comp}} e^{-j2\pi frequency \left(\frac{DelaySymbols}{SymbolRate} \right)}$$

where:

G filt	= 0.0 for frequency ≤ 0.5 × (1 – Alpha) × SymbolRate	
	= 1.0 for frequency ≥ 0.5 × (1 + Alpha) × SymbolRate	
	= [0.5 × (1 + sin[π × (frequency – SymbolRate /2)])	
G comp	= 1.0	if DutyCycle =0
	= [0.01 × DutyCycle × sinc(x)] Exponent	if SincE = YES
	= [0.01 × DutyCycle × sinc(x)]	if SincE = NO
sinc(x)	= sin(x)/x	
x	= 0.01 × DutyCycle × π × frequency / SymbolRate	

5. While Exponent can be any value, the standard value is 1.0 for the ideal raised-cosine filter response or 0.5 to simulate the root raised-cosine filter response when present at both the receiving and transmitting channels.
6. In steady-state frequency-domain analyses, the ideal frequency-domain response described previously is used; however, this ideal response has an infinite duration impulse response that must be approximated for time-domain simulations in either Transient or Circuit Envelope. If DelaySymbols is set too small, then the impulse response will be severely truncated and will not accurately reflect the ideal frequency response. Using a Hanning window (WindowType=1) a DelaySymbols value of 15 should result in equivalent frequency domain sidelobes of –90dBc or smaller.
7. Accuracy of this model in Transient or Circuit Envelope can be further controlled through the ImpMaxFreq, ImpDeltaFreq, and ImpMaxPts parameters.
8. The filter can include gain equalization to compensate for duty cycle roll-off. If DutyCycle = 0.0, then no compensation will be applied. If SincE=YES, Exponent will be applied to the gain compensation term, G comp . The Exponent term is always present in the G filt term.
9. This component has no default artwork associated with it.

LPF_Bessel (Lowpass Filter, Bessel-Thompson)

Symbol

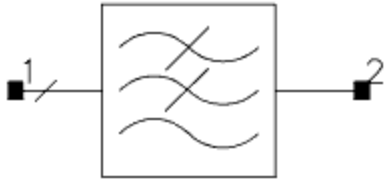

Available in ADS and RFDE

Parameters

Name	Description	Units	Default
Fpass	Passband edge frequency	GHz	1
Apass	Attenuation at passband edges	dB	3
GDpass	Group delay rolloff at passband edge, $0 < \text{GDpass} < 1$	None	0.9
StopType	Stopband input impedance type: OPEN or SHORT	None	open
MaxRej	Maximum rejection level	dB	None
N	Filter order (if $N > 0$, it overwrites BWstop and Astop)); if not given, it is calculated based on BWpass, Apass and GDpass	None	0
IL	Passband insertion loss	dB	0
Qu	Unloaded quality factor for resonators, default setting is an infinite Qu and expresses a dissipationless resonant circuit.	None	1e308
Z1	Input port reference impedance	Ohm	50
Z2	Output port reference impedance	Ohm	50
Temp	Temperature	°C	None

Range of Usage

$F_{pass} > 0$
 $0.01 \leq A_{pass} \leq 3.0$
 $0 < GD_{pass} < 1$
 $1 \leq N \leq 15$
 $Q_u \geq 1$

Notes/Equations

1. Refer to [Filter Categories](#).
2. For information on LPF behavior at DC, refer to [Lowpass Filter Behavior at DC](#).
3. This component has no default artwork associated with it.

LPF_Butterworth (Lowpass Filter, Butterworth)

Symbol

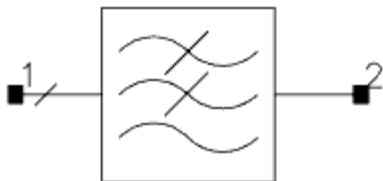

Available in ADS and RFDE

Parameters

Name	Description	Units	Default
Fpass	Passband edge frequency	GHz	1
Apass	Attenuation at passband edges	dB	3

Advanced Design System 2008

Fstop	Stopband edge frequency	GHz	1.2
Astop	Attenuation at stopband edges	dB	20
StopType	Stopband input impedance type: OPEN or SHORT	None	open
MaxRej	Maximum rejection level	dB	None
N	Filter order (if $N > 0$, it overwrites BWstop and Astop)); if not given, it is calculated based on BWpass, Apass and GDpass	None	0
IL	Passband insertion loss	dB	0
Qu	Unloaded quality factor for resonators, default setting is an infinite Qu and expresses a dissipationless resonant circuit.	None	1e308
Z1	Input port reference impedance	Ohm	50
Z2	Output port reference impedance	Ohm	50
Temp	Temperature	°C	None

Range of Usage

$F_{pass} > 0$
 $0.01 \leq A_{pass} \leq 3.0$
 $1 \leq N \leq 15$
 $Q_u \geq 1$

Notes/Equations

1. Refer to [Filter Categories](#).
2. For information on LPF behavior at DC, refer to [Lowpass Filter Behavior at DC](#).
3. This component has no default artwork associated with it.

LPF_Chebyshev (Lowpass Filter, Chebyshev)

Symbol

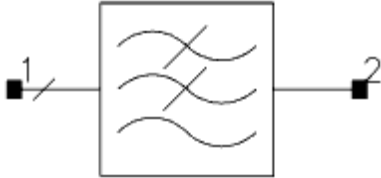

Available in ADS and RFDE

Parameters

Name	Description	Units	Default
Fpass	Passband edge frequency	GHz	1
Apass	Attenuation at passband edges	dB	1
Ripple	Stopband ripple	dB	1
Fstop	stopband edge frequency	GHz	1.2
Astop	Attenuation at stopband edges	dB	20
StopType	Stopband input impedance type: OPEN or SHORT	None	open
MaxRej	Maximum rejection level	dB	None
N	Filter order (if $N > 0$, it overwrites BWstop and Astop)); if not given, it is calculated based on BWpass, Apass and GDpass	None	0
IL	Passband insertion loss	dB	0
Qu	Unloaded quality factor for resonators, default setting is an infinite Qu and expresses a dissipationless	None	1e308

	resonant circuit.		
Z1	Input port reference impedance	Ohm	50
Z2	Output port reference impedance	Ohm	50
Temp	Temperature	°C	None

Range of Usage

$F_{pass} > 0$
 $0.01 \leq \text{Ripple} \leq 3.0$
 $1 \leq N \leq 15$
 $Q_u \geq 1$

Notes/Equations

1. Refer to [Filter Categories](#).
2. For information on LPF behavior at DC, refer to [Lowpass Filter Behavior at DC](#).
3. This component has no default artwork associated with it.

LPF_Elliptic (Lowpass Filter, Elliptic)

Symbol

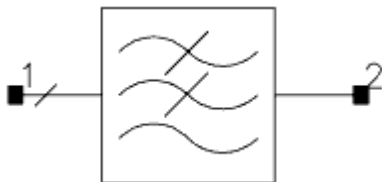

Available in ADS and RFDE

Advanced Design System 2008

Parameters

Name	Description	Units	Default
Fpass	Passband edge frequency	GHz	1
Ripple	Stopband ripple	dB	1
Fstop	Stopband edge frequency	GHz	1.2
Astop	Attenuation at stopband edges	dB	20
StopType	Stopband input impedance type: OPEN or SHORT	None	open
MaxRej	Maximum rejection level	dB	None
N	Filter order (if $N > 0$, it overwrites BWstop and Astop)); if not given, it is calculated based on BWpass, Apass and GDpass	None	0
IL	Passband insertion loss	dB	0
Qu	Unloaded quality factor for resonators, default setting is an infinite Qu and expresses a dissipationless resonant circuit.	None	1e308
Z1	Input port reference impedance	Ohm	50
Z2	Output port reference impedance	Ohm	50
Temp	Temperature	°C	None

Range of Usage

$F_{pass} > 0$
 $0.01 \leq \text{Ripple} \leq 3.0$
 $A_{stop} > 0$
 $1 \leq N \leq 15$

Notes/Equations

1. Refer to [Filter Categories](#).

2. For information on LPF behavior at DC, refer to [Lowpass Filter Behavior at DC](#).
3. This component has no default artwork associated with it.

LPF_Gaussian (Lowpass Filter, Gaussian)

Symbol

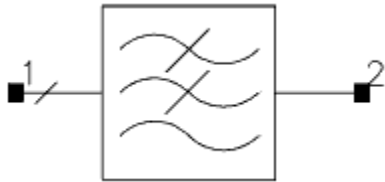

Available in ADS and RFDE

Parameters

Name	Description	Units	Default
Fpass	Passband edge frequency	GHz	1
Apass	Attenuation at passband edges	dB	3
GDpass	Group delay rolloff at passband edge, $0 < \text{GDpass} < 1$	None	0.9
StopType	Stopband input impedance type: OPEN or SHORT	None	open
MaxRej	Maximum rejection level	dB	None
N	Filter order (if $N > 0$, it overwrites BWstop and Astop)); if not given, it is calculated based on BWpass, Apass and GDpass	None	0
IL	Passband insertion loss	dB	0

Qu	Unloaded quality factor for resonators, default setting is an infinite Qu and expresses a dissipationless resonant circuit.	None	1e308
Z1	Input port reference impedance	Ohm	50
Z2	Output port reference impedance	Ohm	50
Temp	Temperature	°C	None

Range of Usage

$F_{pass} > 0$
 $0.01 \leq A_{pass} \leq 3.0$
 $0 < GD_{pass} < 1$
 $1 \leq N \leq 15$
 $Q_u \geq 1$

Notes/Equations

1. Refer to [Filter Categories](#).
2. For information on LPF behavior at DC, refer to [Lowpass Filter Behavior at DC](#).
3. This component has no default artwork associated with it.

LPF_GMSK (Lowpass Filter, GMSK)

Symbol

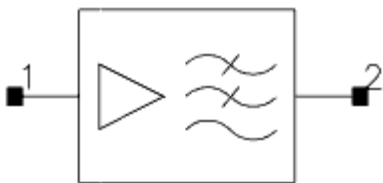

Advanced Design System 2008

Available in ADS and RFDE

Parameters

Name	Description	Units	Default
BT	Bandwidth-Time Product of Gaussian Filter	None	0.3
BitRate	Digital bit rate defining filter bandwidth	kHz	270.833
DelayBits	Number of bits delayed by filter	None	5
Gain	Gain factor	None	1.0
Zout	Output impedance	Ohm	50
WindowType	Window type applied to impulse response: 0=None, 1=Hann, 2=Hamming	None	0
ImpMaxFreq	Maximum frequency to consider when calculating impulse response		
ImpDeltaFreq	Frequency sample spacing when calculating impulse response		
ImpMaxPts	Maximum number of points in impulse response	None	None

Range of Usage

$$0 \leq \text{Alpha} \leq 1$$

$$\text{DelayBits} \geq 1$$

Notes/Equations/Reference

1. Refer to [Filter Categories](#).
2. For information on lowpass filter behavior at DC, refer to [Lowpass Filter Behavior at DC](#).
3. This filter is unidirectional. Its input impedance is infinite and its output impedance is specified by Zout.
4. This Gaussian filter is used in the GMSK modulation system.
5. In the steady-state frequency domain analysis, an ideal frequency-domain response is used. However, this ideal

response has an infinite duration impulse response that must be approximated for time domain simulations in either Transient or Circuit Envelope. If DelayBits is set too small, then the impulse response will be severely truncated and will not accurately reflect the ideal frequency response.

6. A value of 1.0 will be used internally when DelayBits is set to a value that is less than 1.0.
7. Accuracy of this model in Transient or Circuit Envelope can be further controlled through the ImpMaxFreq, ImpDeltaFreq, and ImpMaxPts parameters.
8. This component has no default artwork associated with it.

LPF_PoleZero (Lowpass Filter, Pole Zero)

Symbol

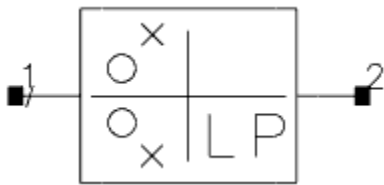

Available in ADS and RFDE

Parameters

Name	Description	Units	Default
Poles	List of complex poles	None	list(-0.7 + j × 0.7,
Zeros	List of complex zeros	None	None
Gain	Gain factor	None	1.0
Fpass	Passband edge frequency	GHz	1
StopType	Stopband input impedance type: OPEN or SHORT	None	open
Z1	Input port reference impedance	Ohm	50
Z2	Output port reference impedance	Ohm	50

Notes/Equations

1. This is an S-domain filter.
2. Poles and Zeros are a list of complex pole/zero locations.

The transfer function for the filter is:

$$S_{21} = Gain \left(\frac{(S - Zero1)(S - Zero2)...}{(S - Pole1)(S - Pole2)...} \right)$$

where

$S = j(\text{Freq} / F_{pass})$

and

Freq is the analysis frequency

At least one pole must be supplied.

3. For information on lowpass filter behavior at DC, refer to [Lowpass Filter Behavior at DC](#).

LPF_Polynomial (Lowpass Filter, Polynomial)

Symbol



Available in ADS and RFDE

Parameters

Name	Description	Units	Default
Numerator	List of numerator coefficients	None	list(1)
Denominator	List of denominator coefficients	None	list(1,1.4,1)

Gain	Gain factor	None	1.0
Fpass	Passband edge frequency	GHz	1
StopType	Stopband input impedance type: OPEN or SHORT	None	open
Z1	Input port reference impedance	Ohm	50
Z2	Output port reference impedance	Ohm	50

Notes/Equations

1. This is an S-domain filter.
2. Denominator and Numerator are a list of polynomial coefficients.
The transfer function for the filter is:

$$S_{21} = Gain \left(\frac{N_0 + (N_1 \times S) + (N_2 \times S^2) \dots}{D_0 + (D_1 \times S) + (D_2 \times S^2) \dots} \right)$$

where

$S = j(\text{Freq} / \text{Fpass})$

and

Freq is the analysis frequency

At least one denominator coefficient must be supplied.

3. For information on lowpass filter behavior at DC, refer to [Lowpass Filter Behavior at DC](#).

LPF_RaisedCos (Lowpass Filter, Raised-Cosine)

Symbol

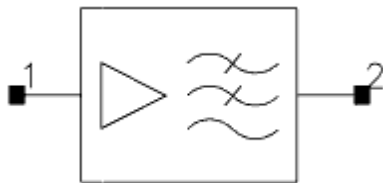

Advanced Design System 2008

Available in ADS and RFDE

Parameters

Name	Description	Units	Default
Alpha	Rolloff factor defining filter excess bandwidth, $0 \leq \text{Alpha} \leq 1$	None	0.35
SymbolRate	Digital symbol rate defining filter bandwidth	kHz	24.3
DelaySymbols	Number of symbols delayed by filter	None	5
Exponent	Exponent factor ($0 \leq \text{Exponent} \leq 1$), to provide for Root Raised-Cosine filter	None	0.5
DutyCycle	Pulse duty cycle in percent, used for sinc(x) correction	None	0
SincE	Flag to include the Exponent factor on the sinc(x) correction: yes or no	None	no
Gain	Gain factor	None	1.0
Zout	Output impedance	Ohm	50
WindowType	Window type applied to impulse response: 0=None, 1=Hann, 2=Hamming	None	0
ImpMaxFreq	Maximum frequency to consider when calculating impulse response		
ImpDeltaFreq	Frequency sample spacing when calculating impulse response		
ImpMaxPts	Maximum number of points in impulse response	None	None
Other	output string to netlist	None	None

Range of Usage

- 0 ≤ Alpha ≤ 1
- DelaySymbols ≥ 1
- 0 ≤ Exponent ≤ 1
- 0 ≤ DutyCycle ≤ 100

Notes/Equations

1. Refer to [Filter Categories](#).
2. For information on lowpass filter behavior at DC, refer to [Lowpass Filter Behavior at DC](#).
3. This filter is unidirectional; input impedance is infinite; output impedance is specified by Zout.
4. Voltage gain is described by the following function.

$$\frac{V_{out}}{V_{in}} = \frac{Gain \times G_{filt}}{G_{comp}} e^{-j2\pi frequency \left(\frac{DelaySymbols}{SymbolRate} \right)}$$

where:

G filt	= 1.0 for frequency ≤ 0.5 × (1 – Alpha) × SymbolRate	
	= 0.0 for frequency ≥ 0.5 × (1 + Alpha) × SymbolRate	
	= [0.5 × (1 – sin[π × (frequency – SymbolRate /2)/	
G comp	= 1.0	if DutyCycle =0
	= [0.01 × DutyCycle × sinc(x)] Exponent	if SincE = YES
	= [0.01 × DutyCycle × sinc(x)]	if SincE = NO
sinc(x)	= sin(x)/x	
x	= 0.01 × DutyCycle × π × frequency / SymbolRate	

5. While Exponent can be any value, the standard value is 1.0 for the ideal raised-cosine filter response or 0.5 to simulate the root raised-cosine filter response when present at both the receiving and transmitting channels.
6. In steady-state frequency-domain analyses, the ideal frequency-domain response described previously is used; however, this ideal response has an infinite duration impulse response that must be approximated for time-domain simulations in either transient or circuit envelope. If DelaySymbols is set too small, then the impulse response will be severely truncated and will not accurately reflect the ideal frequency response. A DelaySymbols value of 15 should result in saturated frequency-domain sidelobes of -75dBc or smaller. This number is approximate and represents the saturated sidelobe level at frequencies far greater than the filter's cutoff frequency. The sidelobes at, say, twice the filter's cutoff frequency have generally not saturated and will typically be higher than -75 dBc. The saturated sidelobe level may depend on whether a transient or circuit envelope simulation is performed and on the window type used. It is significantly lower than -75dBc in many cases. The accuracy of this model in transient or circuit envelope simulations can be further controlled through the ImpMaxFreq, ImpDeltaFreq, and ImpMaxPts parameters.

7. The filter can include gain equalization to compensate for duty cycle roll-off. If DutyCycle = 0.0, then no compensation will be applied. If SincE=YES, Exponent will be applied to the gain compensation term G comp . The Exponent term is always present in the G filt term.
8. This component has no default artwork associated with it.

SAW_Filter (Saw Filter)

Symbol

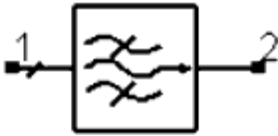

Available in ADS and RFDE

Parameters

Name	Description	Units	Default
Fcenter	Stopband center frequency	MHz	300
IL	Passband insertion loss	dB	15
BWpass	Passband edge-to-edge width	MHz	50
Apass	Attenuation at passband edges	dB	1
BWstop	Stopband edge-to-edge width	MHz	70
Astop	Attenuation at stopband edges	dB	55
GDelay	Group delay	sec	0.4
Aripple	Passband amplitude ripple	dB	0.5
PhaRipple	Passband phase ripple from	deg	None

	linear phase		
MaxRej	Maximum rejection level	dB	
Zin	Input impedance	Ohm	50
Zout	Output impedance	Ohm	50
WindowType	Window type applied to impulse response: 0=None, 1=Hann, 2=Hamming	None	0
Temp	Temperature	°C	None
Other	Output string to netlist	None	None

Range of Usage

$BW_{stop} \geq BW_{pass}$
 $G_{Delay} \geq \pi/BW_{stop}$

Notes/Equations

1. SAW_Filter models the typical behavior of SAW bandpass filters. If the PhaRipple parameter is not specified, the filter will have perfect linear phase.
2. To maintain causality, Gdelay must be set to at least π/BW_{stop} .

Modulators and Demodulators

Introduction

The Filters - < filter type > and System - < device type > palettes contain two fundamentally different types of behavioral system models.

Filters , System - Amps & Mixers , and System - Mod/Demod can be classified as tops-down system models that support a tops-down system design flow where model behaviors are characterized by a small number of independent parameters such as frequency, power and load. They are often referred to as parameter-based behavioral models .

System - Data Models can be classified as bottoms-up system models that support a bottoms-up verification flow

where model behaviors are extracted from a simulation (or measurement) of a transistor-level circuit. They are often referred to as data-based behavioral models .

The parameter-based behavioral models typically provide superior speed relative to the data-based behavioral models with both of these being vastly superior to a brute-force transistor-level simulation.

The data-based behavioral models typically provide superior accuracy relative to the parameter-based behavioral models as they capture actual behaviors of implemented circuit components and not just design specifications.

The differences between parameter - and data-based behavioral models justify a palette emphasis on flow (all data-based behavioral models grouped together) rather than functionality (all amplifiers, mixers, modulators, and demodulators grouped together) and resulted in the addition of a System - Data Models palette.

The use model for parameter-based behavioral models is to simply set a series of parameters prior to using the model. The use model for data-based behavioral models is slightly more involved. For a discussion, refer to Chapter 8, System Data Models.

The modulators and demodulators system model library contains time domain tuned modulators and tuned demodulators. Each component in this library is described following this introduction.

When using the System-Mod/Demod components in the Analog/RF schematic, it is important to note that terminating the component with a load resistance equivalent to the component output resistance will provide an output voltage that is half of the applied input voltage. Consider the Thevenin equivalent of the output of a Mod/Demod component.

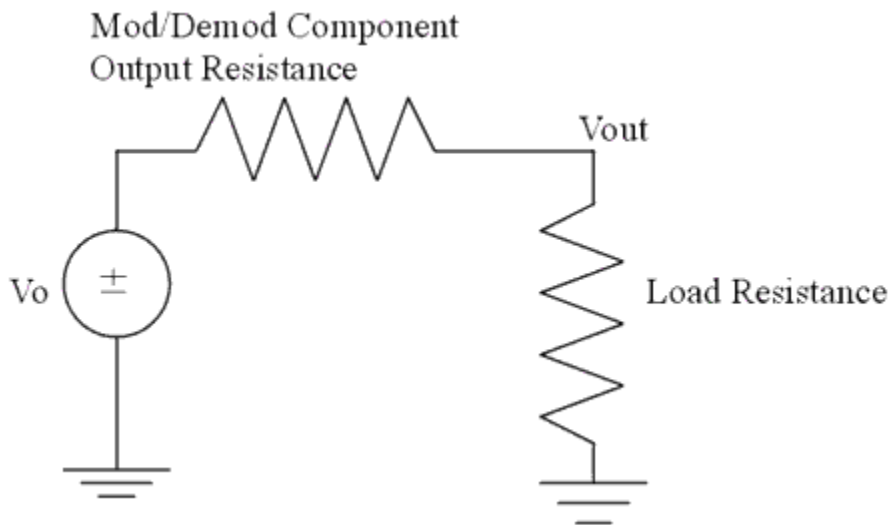

In an Analog/RF schematic, the value for V_{out} will be $1/2 V_o$ when $\text{Output Resistance} = \text{Load Resistance}$. In general, $V_{out} = V_o \times \text{Load Resistance} / (\text{Load Resistance} + \text{Output Resistance})$. Thus, this is the potential divider action. All of the components in the System-Mod/Demod library have this property except for `N_StateDemod` and `PM_UnwrapDemodTuned`. (These two components do not have an R_{out} parameter).

For a similar circuit in a DSP schematic, the effect of the potential divider on the output voltage will not be noticeable when the output resistance equals the load resistance. In this case, V_{out} equals V_o . For the DSP components, there is an additional factor of 2 at the output voltage to cancel the factor of $1/2$ from the potential divider. For a description

of the digital implementation of the modulators and demodulators, and the potential divider action, refer to Introduction: Timed, Modem Components in the Signal Processing component documentation.

AM_DemodTuned (AM Demodulator, Tuned)

Symbol

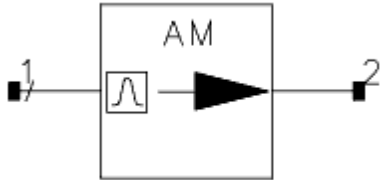

Available in ADS

Parameters

Name	Description	Units	Default
Fnom	Nominal input frequency	GHz	1
Rout	Output resistance	Ohm	50

Notes/Equations

1. This is a tuned demodulator that selects the input harmonic closest to the specified Fnom frequency and generates a baseband output signal equal to the instantaneous amplitude of the selected carrier frequency. If there is no analysis harmonic frequency close enough to the Fnom frequency, a warning is issued and the output is 0. Input impedance is infinite; output impedance is set by Rout, and is limited to a minimum value of 0.1 Ohm. The open circuit output voltage is defined by

$$V_{out_0} = mag(Vin_k)$$

where

$$mag(V) = \sqrt{Re(V)^2 + Im(V)^2}$$

and

k represents the value at the analysis harmonic frequency closest to the Fnom value

0 represents the baseband component of the output voltage. All non-baseband output frequency components are 0.

2. This model generates only the absolute value of the input because the imaginary part of baseband signals is 0 for transient and baseband envelope simulations.

AM_ModTuned (AM Modulator, Tuned)

Symbol

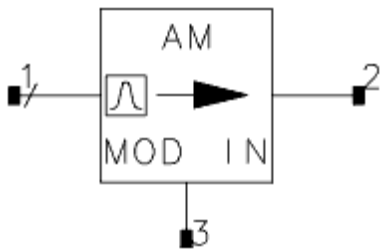

Available in ADS

Parameters

Name	Description	Units	Default
ModIndex	Modulation index	None	1.0
Fnom	Nominal input frequency	GHz	1
Rout	Output resistance	Ohm	50

Notes/Equations

1. This is a tuned modulator that selects the input harmonic defined by the specified Fnom frequency and amplitude modulates it by the baseband modulation input.

If there is no analysis harmonic frequency close enough to the Fnom frequency, a warning is issued and the

output is 0. The two input impedances are infinite. The output impedance is set by Rout, and is limited to a minimum value of 0.1 Ohm. The open circuit output voltage is defined by

$$V_{out_k} = (1 + ModIndex \times V_{mod_0}) \times Vin_k$$

where

k represents the value at the analysis harmonic frequency closest to the Fnom value

0 represents the baseband component of the modulation input voltage.

2. The RF carrier is injected at pin 1; the modulating signal is injected at pin 3. The resulting AM signal is present at pin 2. The RF carrier should be a frequency-domain source; the modulating signal should be a time-domain source.
3. This model works in transient and baseband envelope simulations. Because the describing equation is valid for baseband signals, Fnom has no effect.

FM_DemodTuned (FM Demodulator, Tuned)

Symbol

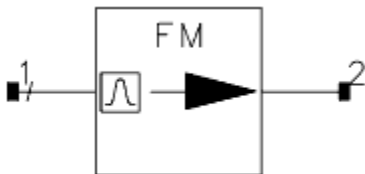

Available in ADS

Parameters

Name	Description	Units	Default
Sensitivity	Demodulation sensitivity, in Hz/Volt	kHz	1
Fnom	Nominal input frequency	GHz	1
Rout	Output resistance	Ohm	50

Notes/Equations

1. This is a tuned demodulator that selects the input harmonic closest to the specified Fnom frequency and generates a baseband output signal equal to the instantaneous frequency of the selected carrier frequency. If there is no analysis harmonic frequency close enough to the Fnom frequency, a warning is issued and the output is 0. Input impedance is infinite; output impedance is set by Rout, and is limited to a minimum value of 0.1 Ohm.

The instantaneous frequency difference is equal to the time derivative of the instantaneous phase. This is approximated using a simple finite difference. As long as the phase does not change by greater than $\pm 180^\circ$ in one time step, the frequency calculation is non-ambiguous. The open circuit output voltage can be described as:

$$V_{out_0} = \frac{\Phi(Vin_k(t)) - \Phi(Vin_k(t - timestep))}{2\pi \times Sensitivity \times timestep}$$

where

$$\Phi(V) = \text{atan} \frac{\text{Im}(V)}{\text{Re}(V)}$$

k represents the value at the analysis harmonic frequency closest to the Fnom value

0 represents the baseband component of the output voltage.

All non-baseband output frequency components are 0.

2. For transient and baseband envelope simulations, this model does not generate the expected results because the imaginary part of baseband signals is 0.

FM_ModTuned (FM Modulator, Tuned)

Symbol

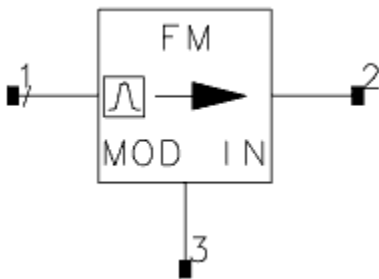

Available in ADS

Parameters

Name	Description	Units	Default
Sensitivity	Modulation sensitivity, in Hz/Volt	kHz	1
Fnom	Nominal input frequency	GHz	1
Rout	Output resistance	Ohm	50

Notes/Equations

1. This is a tuned modulator that selects the input harmonic defined by the specified Fnom frequency and frequency modulates it by the baseband modulation input.

If there is no analysis harmonic frequency close enough to the Fnom frequency, a warning is issued and the output is 0. The two input impedances are infinite. The output impedance is set by Rout, and is limited to a minimum value of 0.1 Ohm. The open circuit output voltage is defined by

$$V_{out_k} = e^{j2\pi Sensitivity \int_0^t V_{m_0} dt} \times V_{in_k}$$

where

k represents the value at the analysis harmonic frequency closest to the Fnom value

0 represents the baseband component of the modulation input voltage.

For time t=0, the integrator of the modulation input signal is reset to 0. In all steady-state analyses such as harmonic balance, dc, and ac, time is kept at 0, so no modulation occurs.

2. The RF carrier is injected at pin 1; the modulating signal is injected at pin 3. The resulting FM signal is present at pin 2. The RF carrier should be a frequency-domain source; the modulating signal should be a time-domain source.
3. This model will not function as a frequency modulator in transient and baseband envelope simulations because of the use of the complex exponential operator.

Unable to render {include} Couldn't find a page to include called: [IQ DemodTuned (I/Q Demodulator, Tuned)]

Unable to render {include} Couldn't find a page to include called: [IQ ModTuned (I/Q Modulator, Tuned)]

N_StateDemod (N-State Demodulator)

Symbol

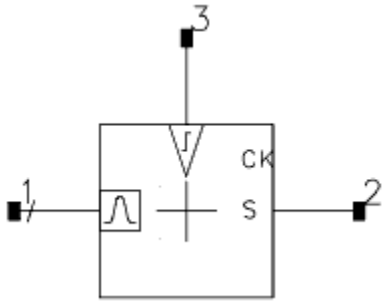

Available in ADS

Parameters

Name	Description	Units	Default
Fnom	Nominal input frequency	GHz	1
StateArray	Complex array of state values	None	list(1+j,-1+j,-1-j,1-j)

Notes/Equations

1. This is a tuned demodulator that selects the input harmonic closest to the specified Fnom frequency and generates a baseband output state signal representing the nearest complex nominal state of the selected carrier at the time of last rising clock edge.
If there is no analysis harmonic frequency close enough to the Fnom frequency, a warning is issued and the output is 0. On each rising clock edge, the I/Q information of the carrier is sampled. Using a Euclidean distance measure, the closest nominal state in the StateArray variable is determined and that state number, minus 1, is output as the baseband state voltage. This can be considered a 2-dimensional quantizer.
2. The nominal state locations are arbitrary and user definable in the StateArray variable, which can be created from a list of complex values using the list() function.
3. In transient and baseband envelope simulations, this state demodulation model functions correctly and could be used as a 1-dimensional arbitrary state quantizer.

N_StateMod (N-State Modulator)

Symbol

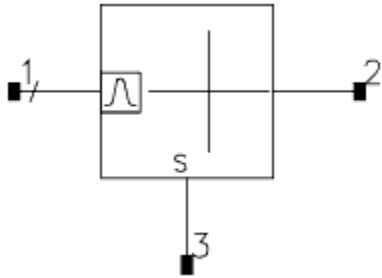

Available in ADS

Parameters

Name	Description	Units	Default
MaxStates	Maximum number of input states	None	4
StateArray	Complex array of state values	None	list(1+j,-1+j,-1-j,1-j)
Fnom	Nominal input frequency	GHz	1
Rout	Output resistance	Ohm	50

Notes/Equations

1. This N-state modulator can be used to create an arbitrary, user-defined constellation of complex modulation states. The input harmonic closest to the specified Fnom frequency is selected and modulated by a sequence of complex states.

If there is no analysis harmonic frequency close enough to the Fnom frequency, a warning is issued and the output is 0. The states are defined by the complex array variable StateArray. The sequence of states is determined by the baseband component of the state modulation input. The two input impedances are infinite; output impedance is set by Rout, and is limited to a minimum value of 0.1 Ohm. The open circuit output voltage is defined by

$$V_{out_k} = State[int(V_{s0}) + 1] \times Vin_k$$

where

k represents the value at the analysis harmonic frequency closest to the Fnom value

0 represents the baseband component of the modulation state input voltage; this input voltage is internally limited to be between 0 and MaxStates - 1.

The StateArray variable can be created from list of complex values using the list() function.

- This model will not function as a complex modulator in transient and baseband envelope simulations if complex state values are specified.
- [16-State Modulation Example](#) and [Simulation Results](#) show a schematic example and simulation results for a 16-state modulator being swept linearly through all 16 of its states.

```

VAR
VAR1
myqam16=list(1,3,2-j*1,1-j*2,-3*j,-1-j*2,-2-j*1,-3,-2+j*1,-1+j*2,3*j,1+2*j,2+1*j,1*j,-1,-1*j)
f1=100MHz
    
```

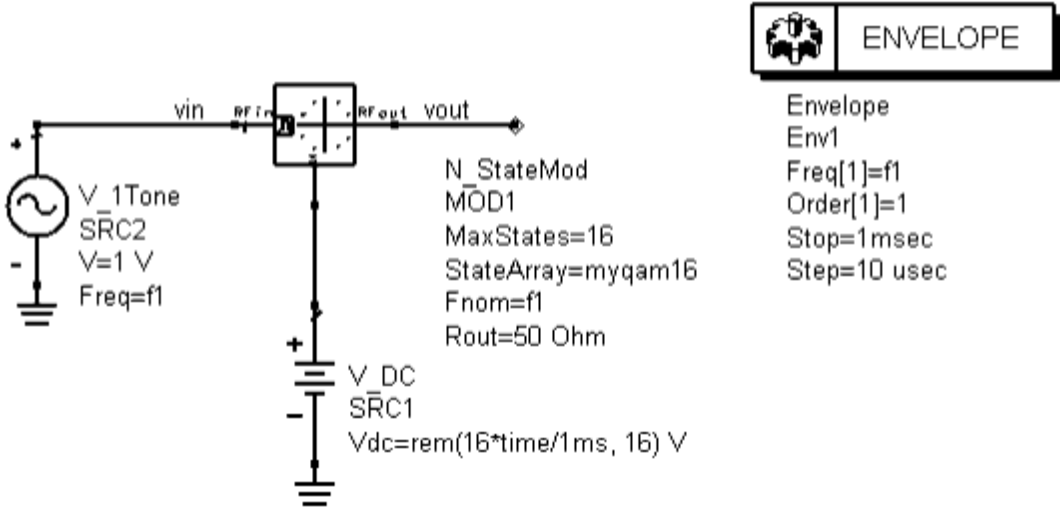

16-State Modulation Example

Eqn $I_{out} = \text{real}(v_{out}[1])$ Eqn $Q_{out} = \text{imag}(v_{out}[1])$

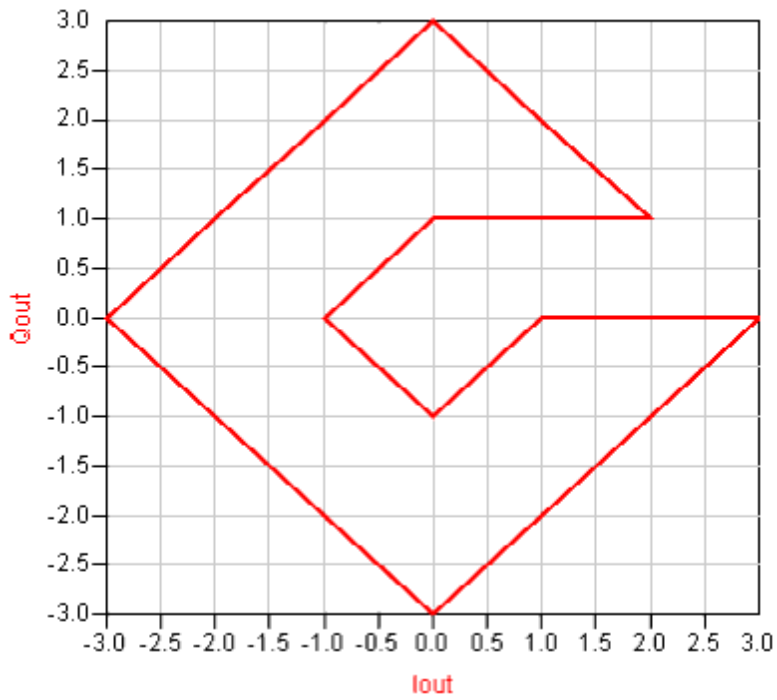

Simulation Results

Unable to render {include} Couldn't find a page to include called: [PI4DQPSK ModTuned (PI/4 DQPSK Modulator, Tuned)]

PM_DemodTuned (PM Demodulator, Tuned)

Symbol

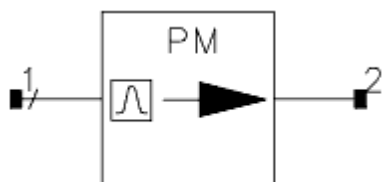

Available in ADS

Parameters

Name	Description	Units	Default
Sensitivity	Demodulation sensitivity, in deg/Volt	deg	180/pi
Fnom	Nominal input frequency	GHz	1
Rout	Output resistance	Ohm	50

Notes/Equations

- This is a tuned demodulator that selects the input harmonic closest to the specified Fnom frequency and generates a baseband output signal equal to the instantaneous phase of the selected carrier frequency. If there is no analysis harmonic frequency close enough to the Fnom frequency, a warning is issued and the output is 0. The input impedance is infinite. The output impedance is set by Rout, and is limited to a minimum value of 0.1 Ohm. The open circuit output voltage is defined by

$$V_{out_0} = \frac{\Phi(Vin_k(t)) \times 180}{\pi \times Sensitivity}$$

where

$$\Phi(V) = \text{atan} \frac{Im(V)}{Re(V)}$$

k represents the value at the analysis harmonic frequency closest to the Fnom value

0 represents the baseband component of the output voltage.

All non-baseband output frequency components are 0.

The maximum phase range of this demodulator is $\pm 180^\circ$.

- In transient and baseband envelope simulations, this model does not generate the expected results because the imaginary part of baseband signals is 0.

PM_ModTuned (PM Modulator, Tuned)

Symbol

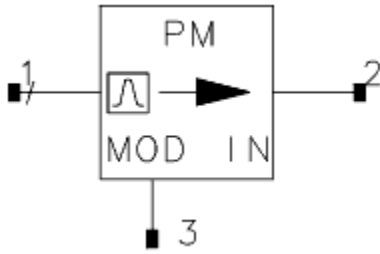

Available in ADS

Parameters

Name	Description	Units	Default
Sensitivity	Modulation sensitivity, in deg/Volt	deg	10
Fnom	Nominal input frequency	GHz	1
Rout	Output resistance	Ohm	50

Notes/Equations

1. This is a tuned modulator that selects the input harmonic defined by the specified Fnom frequency and phase modulates it by the baseband modulation input. If there is no analysis harmonic frequency close enough to the Fnom frequency, a warning is issued and the output is 0. The two input impedances are infinite. The output impedance is set by Rout, and is limited to a minimum value of 0.1 Ohm. The open circuit output voltage is defined by

$$V_{out_k} = e^{j\pi Sensitivity \times (V_{mod_0}) / 180} \times Vin_k$$

where

k represents the value at the analysis harmonic frequency closest to the Fnom value

0 represents the baseband component of the modulation input voltage.

2. The RF carrier is injected at pin 1; the modulating signal is injected at pin 3. The resulting PM signal is present at pin 2. The RF carrier should be a frequency-domain source; the modulating signal should be a time-domain source.
3. This model will not function as a phase modulator in transient and baseband envelope simulations because of the use of the complex exponential operator.

PM_UnwrapDemodTuned (PM Unwrapped Demodulator, Tuned)

Symbol

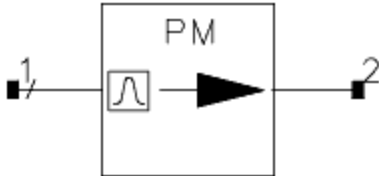

Available in ADS

Parameters

Name	Description	Units	Default
Sensitivity	Demodulation sensitivity, in deg/Volt	deg	10
Fnom	Nominal input frequency	GHz	1
MaxAngle	Unwrapped phase angle range (+/- MaxAngle)	deg	3600

Notes/Equations

- This is a tuned demodulator that selects the input harmonic closest to the specified Fnom frequency and generates a baseband output signal equal to the instantaneous unwrapped phase of the selected carrier frequency.
If there is no analysis harmonic frequency close enough to the Fnom frequency, a warning is issued and the output is 0. The input impedance is infinite. The output impedance is 0.
- The phase range of this demodulator is equal to \pm MaxAngle. The phase at time 0 is set equal to the normal $\square 180^\circ$ phase of the selected carrier frequency. By tracking modulo 360° phase transitions, the unwrapped phase, relative to the initial time 0 value, is calculated. The user can then set the desired modulo range with the MaxAngle parameter. A large number will generate totally unwrapped phase.
This unwrapping of phase works for time sweeps in envelope analyses; it cannot be used to unwrap the phase of frequency or other parameter sweeps.
- In transient and baseband envelope simulations, this model does not generate the expected results because the imaginary part of baseband signals is 0.

QPSK_ModTuned (QPSK Modulator, Tuned)

Symbol

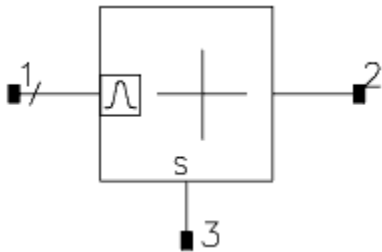

Available in ADS

Parameters

Name	Description	Units	Default
Fnom	Nominal input frequency	GHz	1
Rout	Output resistance	Ohm	50
State1	Complex modulation coordinates of State 1	None	$\exp(-j \times 1 \times \pi/4)$
State2	Complex modulation coordinates of State 2	None	$\exp(-j \times 3 \times \pi/4)$
State3	Complex modulation coordinates of State 3	None	$\exp(-j \times 5 \times \pi/4)$
State4	Complex modulation coordinates of State 4	None	$\exp(-j \times 7 \times \pi/4)$

Notes/Equations

1. This tuned quadrature phase shift keying (QPSK) modulator is actually an arbitrary 4-state modulator. The input

harmonic closest to the specified Fnom frequency is selected and modulated by one of four user-defined complex values. If there is no analysis harmonic frequency close enough to the Fnom frequency, a warning is issued and the output is 0.

The complex values are determined by the baseband component of the state modulation input. An input less than 0.5V selects State 1; less than 1.5V selects State 2; less than 2.5V selects State 3; and, any input greater than 2.5V selects State 4. The two input impedances are infinite. The output impedance is set by Rout and is limited to a minimum value of 0.1 Ohm. The open circuit output voltage is defined by:

$$Vout_k = State[int(Vs_0 + 1.5)] \times Vin_k$$

where

k represents the value at the analysis harmonic frequency closest to the Fnom value

0 represents the baseband component of the modulation state input voltage.

2. The RF carrier is injected at pin 1; the input bit stream is injected at pin 3. The resulting QPSK signal is present at pin 2. The RF carrier should be a frequency-domain source; the modulating signal should be a time-domain source.
3. This model will not function as a complex modulator in transient and baseband envelope simulations if the specified state values are complex.

Passive System Components

AntLoad (Antenna Load)

Symbol



Illustration

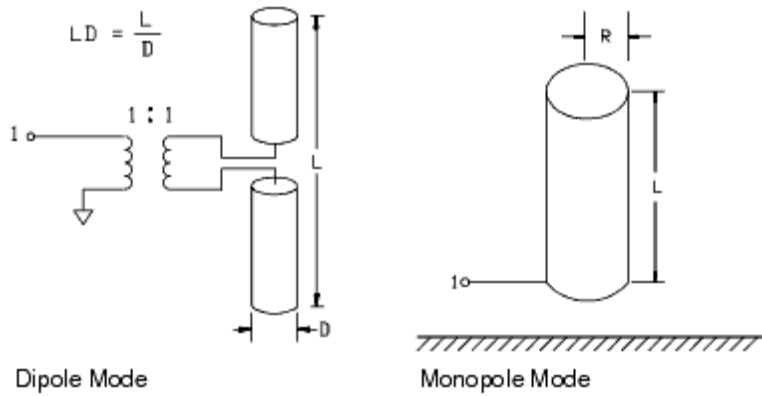

Available in ADS

Parameters

Name	Description	Units	Default
AntType	Antenna type: MONOPOLE or DIPOLE	None	MONOPOLE
Length	Physical antenna length	mil	4e+004
RatioLR	Length-to-radius ratio	None	10

Range of Usage

$$\text{monopole simulation frequency (MHZ)} \leq \frac{287}{L(\text{meters})} \times \frac{\text{RatioLR}}{\text{RatioLR} + 1}$$

$$\text{dipole simulation frequency (MHZ)} \leq \frac{575}{L(\text{meters})} \times \frac{\text{RatioLR}}{\text{RatioLR} + 2}$$

Notes/Equations

1. This component models the input impedance of a monopole or dipole antenna. Transmission is not modeled.
2. For time-domain analysis, the frequency-domain analytical model is used.
3. This component has no default artwork associated with it.

References

1. Constantine A. Balanis, *Antenna Theory: Analysis and Design*, Harper and Row, 1982, pp. 112, 295, 334-335.
2. R. I. Hansen, "Fundamental Limitations in Antennas," *Proceedings of the IEEE*, Vol. 68, No. 2, February, 1981, pp. 170-182.
3. John D. Kraus, *Antennas*, McGraw-Hill Book Company, Inc., 1950, pp. 276-278.

Attenuator (Attenuator)

Symbol

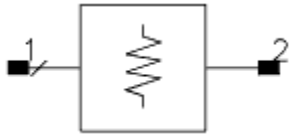

Available in ADS

Parameters

Name	Description	Units	Default
Loss	Attenuation	dB	0
VSWR	Voltage standing wave ratio for both ports	None	1
Rref	Reference resistance for both ports	Ohm	50
Temp	Temperature	°C	None
CheckPassivity	Check passivity flag: if set to yes, a passivity check is performed and a warning is output if the device is not passive; if set to no, a passivity check is not performed.	None	yes
ReturnPhase	Phase characteristic of	None	0

	return loss		
--	-------------	--	--

Range of Usage

VSWR>1.0

Notes/Equations

1. The S-parameters for Attenuator are:

$$|S_{12}| = |S_{21}| = 10^{-(|Loss|/20)}$$

$$\text{Phase}(S_{12}) = \text{Phase}(S_{21}) = 0$$

$$|S_{11}| = |S_{22}| = (VSWR - 1) / (VSWR + 1) \text{ (regarding limiting, refer to Note 2)}$$

$$\text{Phase}(S_{11}) = \text{Phase}(S_{22}) = -90 \text{ if ReturnPhase} < 0$$

$$\text{Phase}(S_{11}) = \text{Phase}(S_{22}) = 0 \text{ if ReturnPhase} = 0$$

$$\text{Phase}(S_{11}) = \text{Phase}(S_{22}) = 90 \text{ if ReturnPhase} > 0$$

2. When ReturnPhase = 0, |S₁₁| and |S₂₂| will be limited to

$$\min(|S_{11}|, 1 - |S_{21}|)$$

in order to maintain passivity constraints.

3. This component will always provide attenuation; for example, either Loss = 20 or Loss = -20 will result in 20 dB attenuation.

4. When used in time domain simulations, set ReturnPhase = 0; any other ReturnPhase value will not produce proper results because (+/-) j in the frequency domain corresponds to a non-causal impulse response in time domain.

5. When checking passivity, remember that infinitesimal numerical differences can make a difference. For example, an Attenuator with

$$|S_{21}| = |S_{12}| = 0.8$$

$$|S_{11}| = |S_{22}| = \sqrt{1 - |S_{21}|^2} = 0.6$$

$$\text{ReturnPhase} < > 0$$

is theoretically passive. However, it may give a non-passivity warning in ADS due to infinitesimal numerical differences. Subtracting a small number, say 1e-12, from all S-parameters should address the problem without causing noticeable changes in the results.

6. CheckPassivity controls whether a separate passivity check is enabled. This is what outputs the Linear S_Port ... is non-passive warning. ReturnPhase controls whether limiting is enabled. This is what outputs the VSWR limited ... warning. When limiting is enabled, it implies a passivity check to find out what limiting, if any, should be done (refer to note 7). This passivity check is silent and never produces a non-passivity warning. When ReturnPhase = 0, VSWR limiting is done before the passivity check if CheckPassivity = yes. This means that for ReturnPhase = 0, a non-passivity warning will never be issued regardless of whether CheckPassivity is set to yes or no. For CheckPassivity = no, a passivity check will not be done; therefore a non-passivity warning will not be output. For CheckPassivity = yes, a passivity check will be done but the parameters have already been limited to ensure passivity so the component will be found to be passive and a non-passivity warning will not be output.

7. This note answers two questions regarding Attenuator:

Q How does Attenuator do its passivity check and how/why does it perform limiting to ensure passivity?

A The S-matrix for this attenuator is

$$S = \begin{bmatrix} S_{11} & S_{12} \\ S_{21} & S_{22} \end{bmatrix}$$

We have

$$S_{12} = 10^{\frac{-abs(Loss)}{20}} = T$$

and we see that T is real and fulfils $0 \leq T \leq 1$ for Loss values from minus infinity to infinity. We also have

$$|S_{11}| = |S_{22}| = scale \times \frac{VSWR^2 - 1}{VSWR^2 + 1} = R$$

where

scale = if (ReturnPhase =0) then 1 elseif (ReturnPhase <0) then -j else j endif

VSWR 2 = if (ReturnPhase =0) then min(VSWR , MaxVSWR) else VSWR endif

MaxVSWR = (1+ MaxR)/(1- MaxR)

MaxR = maximum value of R which guarantees passivity, TBD

and we see that R is real for ReturnPhase =0 and fulfils $0 \leq R \leq 1$ for VSWR values from 1 to infinity. The S-matrix for ReturnPhase =0 is therefore

$$S = \begin{bmatrix} R & T \\ T & R \end{bmatrix}$$

The condition for passivity is that eigenvalues($\text{transpose}(\text{conjugate}(S)) \times S$) ≤ 1 . For the real and symmetric matrix above, this reduces to eigenvalues($S \times S$) ≤ 1 .

We have

$$S \times S = \begin{bmatrix} R^2 + T^2 & 2 \times R \times T \\ 2 \times R \times T & R^2 + T^2 \end{bmatrix}$$

and find the eigenvalues $R^2 - 2 \times R \times T + T^2$ and $R^2 + 2 \times R \times T + T^2$. Letting these eigenvalues equal to 1 (the max value for passivity), we get

$$R^2 - 2 \times R \times T + T^2 = 1 \rightarrow R = -1 + T \text{ and } R = 1 + T$$

$$R^2 + 2 \times R \times T + T^2 = 1 \geq R = -1 - T \text{ and } R = 1 - T$$

and see that eigenvalues ($S \times S$) ≤ 1 implies $R \geq -1 + T$, $R \leq 1 + T$, $R \geq -1 - T$ and $R \leq 1 - T$. For $0 \leq R, T \leq 1$, the first three inequalities are always satisfied and the last one gives $\text{MaxR} = 1 - T$.

Q I have a dissipationless attenuator. It has a given S₂₁ and because it is dissipationless I know that

$$|S_{11}| = \sqrt{1 - |S_{21}|^2}$$

For instance, I might have S₂₁=0.8 and I know that |S₁₁|=0.6 corresponding to a VSWR of 4. I enter S₂₁=0.8 and S₁₁=0.6 for the attenuator but when I simulate I'm told that VSWR is limited to 1.5 corresponding to an S₁₁ value of 0.2. I know that my attenuator is passive with |S₁₁|=0.6. Isn't the limiting by Attenuator too restrictive and wrong?

A Let's examine the above S-matrix. It is

$$\begin{bmatrix} 0.6 & 0.8 \\ 0.8 & 0.6 \end{bmatrix}$$

and it does fulfill

$$\sum_{i=1}^2 (|S_{ij}|^2) = 1 \quad [j = 1, 2]$$

However, for a dissipationless network it must also fulfill

$$\sum_{i=1}^2 (S_{ij} \times \text{conjugate}(S_{iq})) = 0 \quad [j = 1, 2; q = 1, 2; q < > j]$$

and it clearly does not. What is wrong is that S₁₁ = S₂₂ have zero phase.

To remedy this, we could consider

$$\begin{bmatrix} j \times 0.6 & 0.8 \\ 0.8 & j \times 0.6 \end{bmatrix}$$

which fulfills both of the above equations. A similar matrix could be constructed by scaling with -j. These matrices must be entered into ADS with ReturnPhase >0 and ReturnPhase <0, respectively, not the default ReturnPhase =0. For ReturnPhase <>0, no limiting is done on VSWR and the above concern is void. An Attenuator with the original S-matrix is not dissipationless and must be limited in order to be passive.

All this generalizes to N x N matrices. Look, for example, at a standard four-port directional coupler. The elements are not all real. There are j 's floating around. Why? This is why.

A quick check shows that the eigenvalues of

$$\begin{bmatrix} 0.2 & 0.8 \\ 0.8 & 0.2 \end{bmatrix} \times \begin{bmatrix} 0.2 & 0.8 \\ 0.8 & 0.2 \end{bmatrix}$$

are 0.36 and 1.0 and that the eigenvalues of

$$\begin{bmatrix} 0.6 & 0.8 \\ 0.8 & 0.6 \end{bmatrix} \times \begin{bmatrix} 0.6 & 0.8 \\ 0.8 & 0.6 \end{bmatrix}$$

are 0.04 and 1.96 showing again that the circuit corresponding to the former/limited matrix is passive (largest eigenvalue of S x S equals one) while the circuit corresponding to the latter/unlimited matrix is not passive (largest eigenvalue of S x S > 1).

Balun3Port (Balun, 3-port)

Symbol

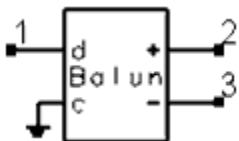

Available in ADS

Parameters

None

Notes/Equations

- Balun3Port realizes the ideal transformation between a balanced differential-mode signal and unbalanced, single-ended signals. It can be useful to connect a source to a differentially fed circuit, although it does ignore common-mode effects.
- Balun3Port realizes the voltage and current transformations given by:

$$v_d = v_+ - v_-$$

$$i_+ = i = -i_d$$
 where
 - v_d / i_d = the differential mode voltage/current at pin d
 - v_+ / i_+ = the single line voltage/current at pin +
 - v_- / i_- = the single line voltage/current at pin -
 See P.R. Gray and R.G. Meyer, "Analysis and Design of Analog Integrated Circuits", Third Edition, John Wiley & Sons, NY, 1993, equations 3.91 & 3.92.
 The minus signs in the current definitions are due to the standard definition of currents directed into the Balun3Port component.
- An equivalent functionality can be realized with a Balun4Port that has the common-mode pin grounded. However, the Balun3Port provides better convergence properties.
- Balun3Port is bi-directional. When fed at the differential-mode pin, it realizes the transformations:

$$v_+ = -v_- = (v_d)/2$$

$$i_+ = -i_- = -i_d$$
- Examples of using Balun3Port to convert between (unbalanced) ADS sources and balanced circuits can be found in the ADS examples directory; access these examples from the ADS Main window > File > Example Project .
 - RFIC > MixerDiffMode_prj demonstrates the use of Balun4Port to present differential-mode sources (as well as common mode biases) to the RF and LO inputs. It also shows the use of Balun3Port to single-ended (differential-mode) IF output, which is needed to properly calculate the noise figure.
 - BehavioralModels > DifferentialModels_prj demonstrates the use of Balun3Port and Balun4Port in conjunction with single-ended System-Data Models in order to create a data-based behavioral model of a differentially fed mixer.

Balun4Port (Balun, 4-port)

Symbol

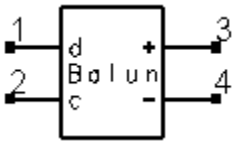

Available in ADS

Parameters

None

Notes/Equations

1. Balun4Port realizes the ideal transformation between balanced (differential- and common-mode) signals and unbalanced (single-ended) signals. It can be used to connect sources to a differentially fed circuit, particularly when modeling common-mode effects are important.
2. Balun4Port realizes voltage and current transformations given by:

$$v_d = v_+ - v_-$$

$$v_c = (v_+ + v_-)/2$$

$$i_d = -(i_+ - i_-)/2$$

$$i_c = -(i_+ + i_-)$$
 where
 - v_d / i_d = differential mode voltage/current at pin d
 - v_c / i_c = common mode voltage/current at pin c
 - v_+ / i_+ = single line voltage/current at pin +
 - v_- / i_- = single line voltage/current at pin -
 See P.R. Gray and R.G. Meyer, "Analysis and Design of Analog Integrated Circuits", Third Edition, John Wiley & Sons, NY, 1993, equations 3.91 and 3.92.
 The minus signs in the current definitions are due to the standard definition of currents directed into the Balun4Port component.
3. Balun4Port is bi-directional. It converts common/differential-mode signals into two single-ended signals, as well as converting two single-ended signals into common/differential mode signals.
4. If common-mode effects are not desired, Balun3Port provides an equivalent, but numerically more robust, result as grounding the common-mode pin of Balun4Port.
5. Examples of using Balun4Port to convert between (unbalanced) ADS sources and balanced circuits can be found in the ADS examples directory; access these examples from the ADS Main window > File > Example Project .
 - RFIC > MixerDiffMode_prj demonstrates the use of Balun4Port to present differential-mode sources (as well as common mode biases) to the RF and LO inputs. It also shows the use of Balun3Port to single-ended (differential-mode) IF output, which is needed to properly calculate the noise figure.
 - BehavioralModels > DifferentialModels_prj demonstrates the use of Balun3Port and Balun4Port in conjunction with single-ended System-Data Models in order to create a data-based behavioral model of a

differentially fed mixer.

Balun6Port (Balun, 6-port)

Symbol

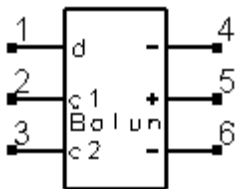

Available in ADS

Parameters

None

Notes/Equations

1. Balun6Port is based on ideal transformers; it can be used to transform a single-ended signal to a differential signal with two ground planes such as a stripline.
2. This component passes DC.

Circulator (Ideal 3-Port Circulator)

Symbol

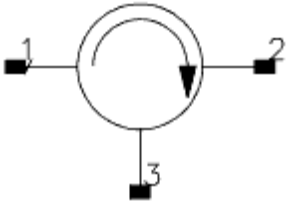

Available in ADS

Parameters

Name	Description	Units	Default
F1	First frequency breakpoint		
F2	Second frequency breakpoint		
F3	Third frequency breakpoint		
Loss1	Attenuation for frequencies $\leq F1$	dB	0
Loss2	Attenuation for $F1 < \text{frequency} \leq F2$	dB	0
Loss3	Attenuation for $F2 > \text{frequency} \leq F3$	dB	0
Loss4	Attenuation for frequencies $> F3$	dB	0
VSWR1	Voltage standing wave ratio at both ports for frequencies $\leq F1$	None	1
VSWR2	Voltage standing wave ratio at both ports for frequencies $> F1, \leq F2$	None	1
VSWR3	Voltage standing wave ratio at both ports for frequencies $> F2, \leq F3$	None	1
VSWR4	Voltage standing wave ratio at both ports for frequencies $> F3$	None	1

Isolat	Isolation	dB	100
Z1	Reference impedance for port 1		
Z2	Reference impedance for port 2		
Z3	Reference impedance for port 3		
Temp	Temperature	°C	None
CheckPassivity	Check passivity flag: if set to yes, a passivity check is performed and a warning is output if the device is not passive; if set to no, a passivity check is not performed.	None	yes

Notes/Equations

1. Up to three frequency breakpoints can be used to define four bands. Each band will have a different Loss# and VSWR#. If no frequencies are specified, then this model is frequency independent and only uses Loss1 and VSWR1.
2. A loss is modeled regardless of the sign of the Loss parameter value.
3. All ports have the same VSWR.
4. Isolation is constant across all frequency bands.
5. The 3×3 S-matrix for Circulator is described by

$$S_{11} = S_{22} = S_{33} = \frac{VSWR - 1}{VSWR + 1}$$

$$S_{12} = S_{23} = S_{31} = 10^{(-abs(Isolat)/20)}$$

$$S_{13} = S_{21} = S_{32} = 10^{(-abs(Loss)/20)}$$

CouplerDual (Dual Coupler)

Symbol

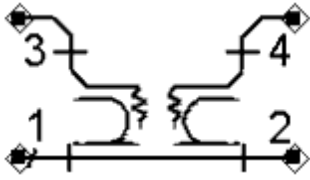

Available in ADS

Parameters

Name	Description	Units	Default
Coupling	Coupling factor	dB	10
F1	First frequency breakpoint		
F2	Second frequency breakpoint		
F3	Third frequency breakpoint		
MVSWR1	Main arm Voltage standing wave ratio for frequency \leq F1	None	1
MVSWR2	Main arm Voltage standing wave ratio for F1 < frequency \leq F2	None	1
MVSWR3	Main arm voltage standing wave ratio for F2 < frequency \leq F3	None	1
MVSWR4	Main arm voltage standing wave ratio for frequency > F3	None	1
CVSWR1	Coupled arm voltage standing wave ratio for frequency \leq F1	None	1
CVSWR2	Coupled arm voltage standing wave ratio for F1 < frequency \leq F2	None	1
CVSWR3	Coupled arm voltage standing wave ratio for F2 < frequency \leq F3	None	1
CVSWR4	Coupled arm voltage	None	1

Advanced Design System 2008

	standing wave ratio for frequency > F3		
Loss1	Attenuation for frequency ≤ F1	dB	0
Loss2	Attenuation for F1 < frequency ≤ F2	dB	0
Loss3	Attenuation for F2 < frequency ≤ F3	dB	0
Loss4	Attenuation for frequency > F3	dB	0
Direct1	Directivity for frequency ≤ F1	dB	100
Direct2	Directivity for F1 < frequency ≤ F2	dB	100
Direct3	Directivity for F2 < frequency ≤ F3	dB	100
Direct4	Directivity for frequency > F3	dB	100
ZRef	Reference impedance for all ports	Ohm	50
Temp	Temperature	°C	None
CheckPassivity	Check passivity flag: if set to yes, a passivity check is performed and a warning is output if the device is not passive; if set to no, a passivity check is not performed.	None	yes

Notes/Equations

1. Port 1 is the input port; port 2 is the through port; port 3 is the coupled port; port 4 is the isolated port. Note that the placement of these pins in ADS differs from many standard textbooks.
2. Both ports of the main arm (ports 1 and 2) are assumed to have the same VSWR. Both ports of the coupled arm (ports 3 and 4) are also assumed to have the same VSWR.
3. Coupling is assumed to be constant across all frequency bands.
4. Loss is the dissipation of the coupler; it affects S21 and S12 only. These S-parameters are calculated as if the coupler was dissipationless and are then scaled by $10^{(-abs(Loss)/20)}$
5. Internally, coupler isolation is calculated as Coupling + Direct in dB.

6. Up to three frequency breakpoints can be used to define four bands, with different directivity losses and VSWR values for each frequency band. If no frequencies are specified, then this model is frequency independent and uses Direct1, Loss1, and VSWR1 only.
7. There is a 90-degree phase shift between the input and the coupled ports.
8. In the coupled arm, the two ports are uncoupled.

CouplerSingle (Single Coupler)

Symbol

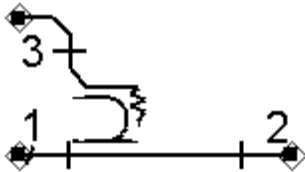

Available in ADS

Parameters

Name	Description	Units	Default
Coupling	Coupling factor	dB	10
F1	First frequency breakpoint		
F2	Second frequency breakpoint		
F3	Third frequency breakpoint		
MVSWR1	Main arm Voltage standing wave ratio for frequency \leq F1	None	1
MVSWR2	Main arm Voltage standing wave ratio for F1 < frequency \leq F2	None	1
MVSWR3	Main arm voltage standing	None	1

Advanced Design System 2008

	wave ratio for $F2 < \text{frequency} \leq F3$		
MVSWR4	Main arm voltage standing wave ratio for frequency $> F3$	None	1
CVSWR1	Coupled arm voltage standing wave ratio for frequency $\leq F1$	None	1
CVSWR2	Coupled arm voltage standing wave ratio for $F1 < \text{frequency} \leq F2$	None	1
CVSWR3	Coupled arm voltage standing wave ratio for $F2 < \text{frequency} \leq F3$	None	1
CVSWR4	Coupled arm voltage standing wave ratio for frequency $> F3$	None	1
Loss1	Attenuation for frequencies $\leq F1$	dB	0
Loss2	Attenuation for $F1 < \text{frequency} \leq F2$	dB	0
Loss3	Attenuation for $F2 > \text{frequency} \leq F3$	dB	0
Loss4	Attenuation for frequencies $> F3$	dB	0
Direct1	Directivity for frequency $\leq F1$	dB	100
Direct2	Directivity for $F1 < \text{frequency} \leq F2$	dB	100
Direct3	Directivity for $F2 < \text{frequency} \leq F3$	dB	100
Direct4	Directivity for frequency $> F3$	dB	100
ZRef	Reference impedance for all ports	Ohm	50
Temp	Temperature	°C	None
CheckPassivity	Check passivity flag: if set to yes, a passivity check is performed and a warning is output if the device is not	None	yes

	passive; if set to no, a passivity check is not performed.		
--	--	--	--

Notes/Equations

1. Port 1 is the input port; port 2 is the through port; port 3 is the coupled port. Note that the placement of these pins in ADS differs from many standard textbooks.
2. Both ports of the main arm (ports 1 and 2) are assumed to have the same VSWR.
3. Coupling is assumed to be constant across all frequency bands.
4. Loss is the dissipation of the coupler; it affects S21 and S12 only. These S-parameters are calculated as if the coupler was dissipationless and are then scaled by $10^{(-abs(Loss)/20)}$
5. Internally, coupler isolation is calculated as Coupling + Direct in dB.
6. Up to three frequency breakpoints can be used to define four bands, with different directivity losses and VSWR values for each frequency band. If no frequencies are specified, then this model is frequency independent and uses Direct1, Loss1, and VSWR1 only.
7. There is a 90-degree phase shift between the input and the coupled ports.
8. In the coupled arm, the two ports are uncoupled.

Gyrator (Gyrator)

Symbol

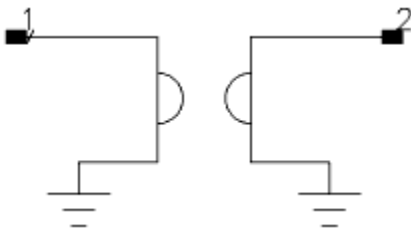

Illustration

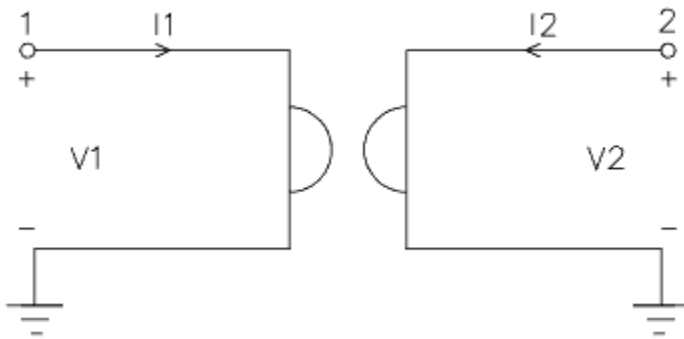

Available in ADS

Parameters

Name	Description	Units	Default
Ratio	Gyrator ratio	None	1

Notes/Equations

$$1. V1 = \text{Ratio} \times I2$$

$$V2 = -\text{Ratio} \times I1$$

$$S_{11} = S_{22} = \frac{r^2 - 1}{r^2 + 1}$$

$$S_{21} = -S_{12} = \frac{-2r}{r^2 + 1}$$

$$r = \frac{\text{Ratio}}{Z_0}$$

Hybrid90 (Ideal 90-degree Hybrid Coupler)

Symbol

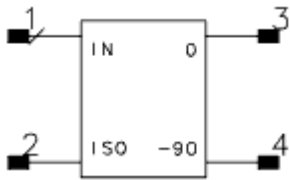

Available in ADS

Parameters

Name	Description	Units	Default
Loss	Insertion loss	dB	0
GainBal	Gain balance between output ports	dB	0
PhaseBal	Phase balance between output ports	deg	0
Rref	Port reference impedance	Ohm	50
Temp	Temperature	°C	None
CheckPassivity	Check passivity flag: if set to yes, a passivity check is performed and a warning is output if the device is not passive; if set to no, a passivity check is not performed.	None	yes
Delay	Time delay for output ports	sec	1.0e-16

Range of Usage

Loss \geq 0 dB
 Delay \geq 1.0e-16 sec

Notes/Equations

1. Although hybrid couplers are typically designed to give an equal power split between the coupled and the direct

ports, the choice of coupling coefficients has been provided here for greater flexibility where a coupling of other than 3 dB is required.

- The loss term is applied to both the coupling and the direct transmission coefficients.
- Pin designations (directional coupler notation/0-90 notation):

(IN) = input port #1

(ISO) = isolated output/input port #2

(0) = coupled output / in-phase output

(-90) = direct output/90-degree phase output

$$|S_{0,IN}|(dB) = -10 \times \log(1 + 10^{(-GainBal/10)}) - Loss$$

$$|S_{-90,IN}|(dB) = -10 \times \log(1 + 10^{(-GainBal/10)}) - Loss - GainBal$$

$$|S_{0,ISO}|(dB) = -10 \times \log(1 + 10^{(-GainBal/10)}) - Loss - GainBal$$

$$|S_{-90,ISO}|(dB) = -10 \times \log(1 + 10^{(-GainBal/10)}) - Loss$$

$$phase(S_{0,IN}) = -360 \times Delay \times frequency(degrees)$$

$$phase(S_{-90,IN}) = -360 \times Delay \times frequency - 90 - PhaseBal(degrees)$$

$$phase(S_{0,ISO}) = -360 \times Delay \times frequency - 90 - PhaseBal(degrees)$$

$$phase(S_{-90,ISO}) = -360 \times Delay \times frequency(degrees)$$

- In general, Hybrid90 is not recommended for time-domain simulation. For the typical case of PhaseBal=0, time domain simulation will not produce proper results for S_{-90,IN} , or S_{0,ISO} because () in the frequency domain corresponds to a non-causal impulse response in time domain.
- This component has no default artwork associated with it.

Hybrid180 (Ideal 180-degree Hybrid Coupler)

Symbol

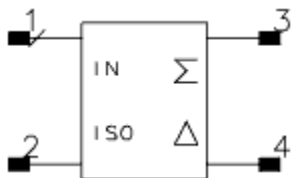

Available in ADS

Advanced Design System 2008

Parameters

Name	Description	Units	Default
Loss	Insertion loss	dB	0
GainBal	Gain balance between output ports	dB	0
PhaseBal	Phase balance between output ports	deg	0
Rref	Port reference impedance	Ohm	50
Temp	Temperature	°C	None
CheckPassivity	Check passivity flag: if set to yes, a passivity check is performed and a warning is output if the device is not passive; if set to no, a passivity check is not performed.	None	yes
Delay	Time delay for output ports	sec	1.0e-16

Range of Usage

Loss ≥ 0 dB
 Delay $\geq 1.0e-16$ sec

Notes/Equations

- Although hybrid couplers are typically designed to give an equal power split between the coupled and the direct ports, the choice of coupling coefficient has been provided here for greater flexibility where a coupling of other than 3 dB is required.
- The loss term is applied to both the coupling and the direct transmission coefficients.
- Pin designations (directional coupler notation/sum-difference notation):
 (IN) = input port/input port#1
 (ISO) = isolated output/input port #2
 (Σ) = coupled output/summation output
 (Δ) = direct output/difference output

$$|S_{\Sigma, IN}|(dB) = -10 \times \log(1 + 10^{(-GainBal/10)}) - Loss - GainBal$$

$$|S_{\Delta, IN}|(dB) = -10 \times \log(1 + 10^{(-GainBal/10)}) - Loss$$

$$|S_{\Sigma, ISO}|(dB) = -10 \times \log(1 + 10^{(-GainBal/10)}) - Loss$$

$$|S_{\Delta,ISO}|(dB) = -10 \times \log(1 + 10^{(-GainBal/10)}) - Loss - GainBal$$

$$phase(S_{\Sigma,IN}) = -360 \times Delay \times frequency - PhaseBal (degrees)$$

$$phase(S_{\Delta,IN}) = -360 \times Delay \times frequency (degrees)$$

$$phase(S_{\Sigma,ISO}) = -360 \times Delay \times frequency (degrees)$$

$$phase(S_{\Delta,ISO}) = -360 \times Delay \times frequency - PhaseBal + 180 (degrees)$$

4. When used in time domain simulation, set PhaseBal=0; for any PhaseBal value other than $n \times 180$, time domain simulation will not produce proper results because the frequency domain specification corresponds to a non-causal impulse response in time domain.
5. This component has no default artwork associated with it.

IsolatorSML (SMLIsolator)

Symbol

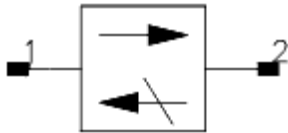

Available in ADS

Parameters

Name	Description	Units	Default
F1	First frequency breakpoint		
F2	Second frequency breakpoint		
F3	Third frequency breakpoint		
Loss1	Attenuation for frequencies $\leq F1$	dB	0
Loss2	Attenuation for $F1 <$	dB	0

Advanced Design System 2008

	frequency $\leq F2$		
Loss3	Attenuation for $F2 >$ frequency $\leq F3$	dB	0
Loss4	Attenuation for frequencies $> F3$	dB	0
VSWR1	Voltage standing wave ratio at both ports for frequencies $\leq F1$	None	1
VSWR2	Voltage standing wave ratio at both ports for frequencies $> F1, \leq F2$	None	1
VSWR3	Voltage standing wave ratio at both ports for frequencies $> F2, \leq F3$	None	1
VSWR4	Voltage standing wave ratio at both ports for frequencies $> F3$	None	1
Isolat	Isolation	dB	100
Z1	Reference impedance for port 1		
Z2	Reference impedance for port 2		
Temp	Temperature	$^{\circ}\text{C}$	None
CheckPassivity	Check passivity flag: if set to yes, a passivity check is performed and a warning is output if the device is not passive; if set to no, a passivity check is not performed.	None	yes

Notes/Equations

1. All ports are assumed to have the same VSWR.
2. Isolation is assumed to be constant across all frequency bands.
3. Up to three frequency breakpoints can be used to define four bands, with different losses and VSWR for each frequency band. If frequencies are not specified, this model is frequency independent and uses Loss1 and VSWR1 only.

LOS_Link (Line-Of-Sight Antenna Link)

Symbol



Available in ADS

Parameters

Name	Description	Units	Default
CenterFreq	Link center frequency	GHz	1
BW	Link bandwidth	MHz	100
TxGain	Transmitting antenna gain	dB	0
TxVSWR	Transmitting antenna VSWR	None	1
TxParabolaD	Transmitting parabolic antenna diameter; overwrites TxGain		
TxEfficiency	Transmitting parabolic antenna efficiency; overwrites TxGain	None	None
RxGain	Receiving antenna gain	dB	0
RxVSWR	Receiving antenna VSWR	None	1
RxParabolaD	Receiving parabolic antenna diameter; overwrites RxGain		
RxEfficiency	Receiving parabolic antenna efficiency; overwrites RxGain	None	None
RxNoiseTemp	Receiving antenna noise temperature	K	150
PathLength	Line-of-sight path length	km	10

NotchFreq	Notch frequency due to ground reflection path interference		
NotchDepth	Power of reflected ray relative to direct ray	dB	None
DeltaDelay	Time delay of ground reflection path w.r.t. LOS path		
Z1	Transmitting antenna reference impedance	Ohm	50
Z2	Transmitting antenna reference impedance	Ohm	50

Range of Usage

PathLength > 10 wavelengths

Notes/Equations

1. Pathloss is infinite outside a window defined by BW.
2. Transmitting antenna gain can be defined by TxGain or by TxParabolaD and TxEfficiency. If all three parameters are specified, TxParabolaD and TxEfficiency will overwrite TxGain. The same applies to receiving antenna as well.
3. The S-Parameter and noise implementation of this model is as follows. S11, S22, S12, S21, and I_Noise are derived from the user-specified LOS_link parameters.

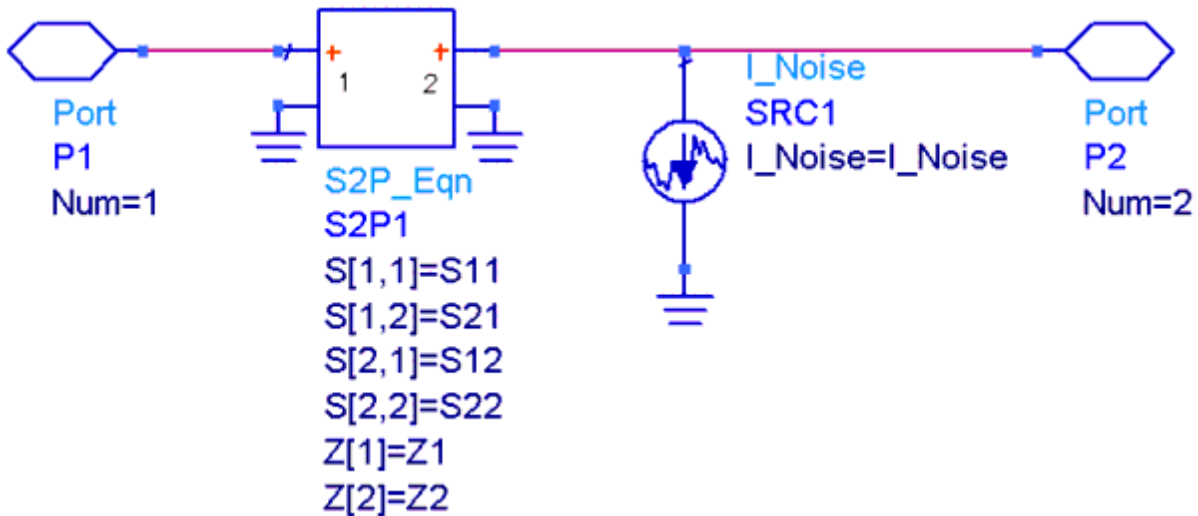

Pad (Pi or Tee Format)

Symbol

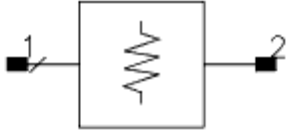

Available in ADS

Parameters

Name	Description	Units	Default
NetType	Network type: Pi or Tee	None	Pi
Loss	Attenuation	dB	0
R1	Reference resistance for port 1	Ohm	50
R2	Reference resistance for port 2	Ohm	50
Temp	Temperature	°C	None
CheckPassivity	Check passivity flag: if set to yes, a passivity check is performed and a warning is output if the device is not passive; if set to no, a passivity check is not performed.	None	yes

Range of Usage

 $R1 > 0$
 $R2 > 0$

Notes/Equations

1. This 2-port component provides a:
 - Match to resistance R_1 at port 1 when port 2 is terminated in R_2
 - Match to R_2 at port 2 when port 1 is terminated in R_1
 - Desired attenuation, DB
2. Resistive networks can achieve simultaneous match at input and output if the insertion loss factor A exceeds a minimum value given by

$$A_{min} = 2 \times \frac{R_1}{R_2} \times \left(1 + \sqrt{1 - \frac{R_2}{R_1}} \right) - 1.0 \quad R_1 > R_2$$

$$2 \times \frac{R_2}{R_1} \times \left(1 + \sqrt{1 - \frac{R_1}{R_2}} \right) - 1.0 \quad R_2 > R_1$$

where:

$$DB \text{ MIN} = 10 \times \log_{10} (A \text{ MIN})$$

3. The values shown in the Pi network equivalent circuit are given by:

$$G_c = 2 \times \frac{\sqrt{A}}{(A - 1) \times \sqrt{R_1 \times R_2}}$$

$$G_a = \frac{A + 1}{(A - 1) \times Z_1} - G_c$$

$$G_b = \frac{A + 1}{(A - 1) \times R_2} - G_c$$

The values shown in the Tee network circuits are given by

$$R_c = \frac{2 \times \sqrt{A} \times \sqrt{R_1 \times R_2}}{(A - 1)}$$

$$R_a = \frac{R_1 \times (A + 1)}{A - 1} - R_c$$

$$R_b = \frac{R_2 \times (A + 1)}{A - 1} - R_c$$

Equivalent Circuit

Pi Network

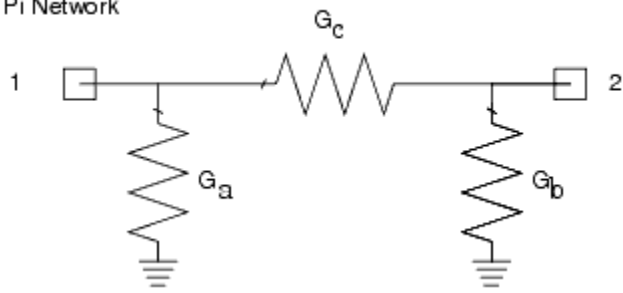

Tee Network

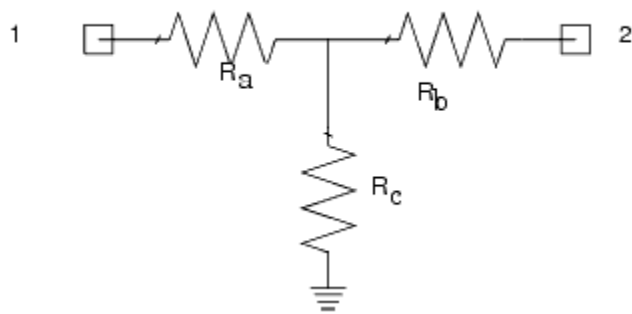

PhaseShiftSML (Phase Shifter)

Symbol

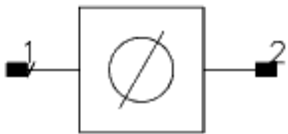

Available in ADS

Parameters

Advanced Design System 2008

Name	Description	Units	Default
Phase	Phase shift	deg	90
PhaseSlope	Phase slope per frequency octave	None	None
FreqStart	Frequency where slope begins		
RTConj	Apply reverse transmission conjugate: yes or no	None	no
ZRef	Reference impedance for all ports	Ohm	50

Range of Usage

FreqStart ≥ 0

Notes/Equations

- The output frequency spectrum is equal to the input spectrum shifted by the specified phase.
- $\theta(f) = \text{Phase}$ (for $\text{freq} < \text{FreqStart}$)
 $\theta(f) = \text{Phase} + \text{PhaseSlope} \times \text{LOG}_2(\text{freq} / \text{FreqStart})$ (for $\text{freq} \geq \text{FreqStart}$)
 if $\text{FreqStart} = 0$, then phase slope is 0 regardless of the PhaseSlope setting
 where freq = simulation frequency
- $$\frac{V_2}{V_1} = \frac{I_2}{I_1} = e^{j\theta(f)}$$

$$S_{11} = S_{22} = 0$$

$$S_{21} = e^{j\theta(f)}$$

if RTConj = NO, $S_{12} = S_{21}$
 if RTConj = YES, $S_{12} = S_{21}^*$
- The S-parameter implementation for the phase shifter is shown here:

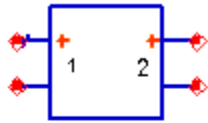

S2P_Eqn
 S2P1
 $S[1,1]=0$
 $S[1,2]=S12$
 $S[2,1]=S21$
 $S[2,2]=0$
 $Z[1]=ZRef$
 $Z[2]=ZRef$

5. In general, PhaseShiftSML is not recommended for time domain simulation. For the special case of $n \times 180^\circ$ phase shift, time domain simulation produces proper results; for the extreme case of $n \times 90^\circ$ phase shift, time domain simulation will not produce proper results because $(\pm)j$ in the frequency domain corresponds to a non-causal impulse response in time domain.

PwrSplit2 (2-Way Power Splitter)

Symbol

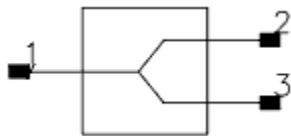

Available in ADS

Parameters

Name	Description	Units	Default
S21	Transmission Coefficient, port1 to port2, complex	None	0.707

	number: $1 + j \times 0$, polar(), dbpolar()		
S31	Transmission coefficient, port1 to port3, complex number: $1 + j \times 0$, polar(), dbpolar()	None	0.707
S11	Port1 reflection coefficient, complex number: $1 + j \times 0$, polar(), dbpolar()	None	0
S22	Port2 reflection coefficient, complex number: $1 + j \times 0$, polar(), dbpolar()	None	0
Isolation	Isolation between port 2 and port 3	dB	100
ZRef	Reference impedance for all ports	Ohm	50
Temp	Temperature	°C	None
CheckPassivity	Check passivity flag: if set to yes, a passivity check is performed and a warning is output if the device is not passive; if set to no, a passivity check is not performed.	None	yes
Delay	Time delay		

Notes/Equations

1. $S_{12} = S_{21}$, $S_{13} = S_{31}$, $S_{33} = S_{22}$
2. PwrSplit2 can also be used as a power combiner.
3. Use the functions polar(), dbpolar() to represent the S-parameters in terms of magnitude, phase or dB, phase.

PwrSplit3 (3-Way Power Splitter)

Symbol

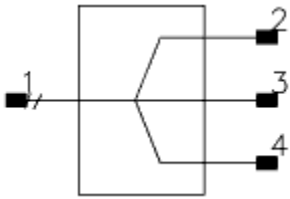

Available in ADS

Parameters

Name	Description	Units	Default
S21	Transmission coefficient, port1 to port2, complex number: $1 + j \times 0$, polar(), dbpolar()	None	0.577
S31	Transmission coefficient, port1 to port3, complex number: $1 + j \times 0$, polar(), dbpolar()	None	0.577
S41	Transmission coefficient, port1 to port4, complex number: $1 + j \times 0$, polar(), dbpolar()	None	0.577
ZRef	Reference impedance for all ports	Ohm	50
Temp	Temperature	°C	None
CheckPassivity	Check passivity flag: if set to yes, a passivity check is performed and a warning is output if the device is not passive; if set to no, a passivity check is not performed.	None	yes
Delay	Time delay		

Notes/Equations

1. Ideal isolation exists for S_{23} , S_{24} , S_{32} , S_{34} , S_{42} , and S_{43} , that is,
 $S_{23} = S_{32} = S_{24} = S_{42} = S_{34} = S_{43} = 0$.
2. Ideal match exists for S_{11} , S_{22} , S_{33} , and S_{44} , that is,
 $S_{11} = S_{22} = S_{33} = S_{44} = 0$.
3. $S_{12} = S_{21}$, $S_{13} = S_{31}$ and $S_{14} = S_{41}$.
4. PwrSplit3 can also be used as a power combiner.
5. Use the functions `polar()`, `dBpolar()` to represent the S-parameters in terms of magnitude, phase or dB, phase.

TimeDelay (Time Delay)

Symbol

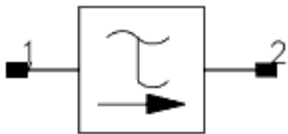

Available in ADS

Parameters

Name	Description	Units	Default
Delay	Time delay	sec	1.0e-6
RTConj	Apply reverse transmission conjugate: NO, YES	None	no
ZRef	Reference impedance for all ports	Ohm	50

Range of Usage

Delay ≥ 0

Notes/Equations

1. The input frequency spectrum has a linear phase shift applied resulting in the output time waveform being a time shifted replication of the input waveform.
2. $S_{21} = e^{-j \omega \text{ Delay}}$
 $S_{11} = S_{22} = 0$
 $\omega = 2\pi f$
 if RTConj = NO, $S_{12} = S_{21}$
 if RTConj = YES, $S_{12} = S_{21}^*$
3. Excessive values for the Delay parameter require large memory for Circuit Envelope and Transient simulations. For Circuit Envelope simulations, a safeguard limits any excessive delay to one-half of the stop time.

Transformer (Ideal 4-Port Transformer)

Symbol

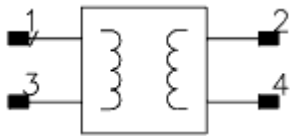

Available in ADS

Parameters

Name	Description	Units	Default
N	Turns ratio		
ZRef	Reference impedance for all ports		

Range of Usage

$N \neq 0$

Notes/Equations

Note This component is obsolete for new designs. It is available only for compatibility with designs created with 2002C or earlier releases.

For new designs, use the TF transformer (Lumped-Components library).

1. Input pins are 1 and 3; output pins are 2 and 4.
2. The S-parameters of the component are determined as follows:
 $S_{11} = S_{24} = S_{33} = S_{42} = N^2 / (1 + N^2)$
 $S_{14} = S_{23} = S_{32} = S_{41} = -N / (1 + N^2)$
 $S_{12} = S_{21} = S_{34} = S_{43} = N / (1 + N^2)$
 $S_{13} = S_{22} = S_{31} = S_{44} = 1 / (1 + N^2)$
3. The input resistance R_{IN} output resistance R_{OUT} are related to N by:

$$\sqrt{\frac{R_{IN}}{R_{OUT}}} = N$$

4. This is a noiseless component.
5. Because it is an ideal transformer, the impedance transformation is the same at DC as it is at nonzero frequencies.
6. This component passes DC.

TransformerG (Transformer with Ground Reference)

Symbol

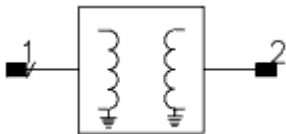

Available in ADS

Parameters

Name	Description	Units	Default
N	Turns ratio		
ZRef	Reference impedance for all ports		

Range of Usage

$N \neq 0$

Notes/Equations

i Note This component is obsolete for new designs. It is available only for compatibility with designs created with 2002C or earlier releases.)

For new designs use the TF transformer (Lumped-Components library) .

1. The input resistance R_{IN} and R_{OUT} are related to N by:

$$\sqrt{\frac{R_{IN}}{R_{OUT}}} = N$$

TwoPort (2-Port Model)

Symbol

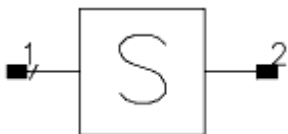

Available in ADS

Parameters

Name	Description	Units	Default
S21	Forward transmission coefficient, complex number: $1 + j \times 0$, polar(), dbpolar()	None	1
S12	Reverse transmission coefficient, complex number: $1 + j \times 0$, polar(), dbpolar()	None	1
S11	Port1 reflection coefficient, complex number: $1 + j \times 0$, polar(), dbpolar()	None	0
S22	Port2 reflection coefficient, complex number: $1 + j \times 0$, polar(), dbpolar()	None	0
ZRef	Reference impedance for all ports	Ohm	50
Temp	Temperature	°C	
CheckPassivity	Check passivity flag: if set to yes, a passivity check is performed and a warning is output if the device is not passive; if set to no, a passivity check is not performed.	None	yes
Delay	Time delay		

Notes/Equations

1. Use the functions polar(), dBpolar() to represent the S-parameters in terms of magnitude, phase or dB, phase.
2. The block parameters must be passive for the noise performance to be as expected.

Phase Lock Loop Components

DivideByN (Divide by N)

Symbol

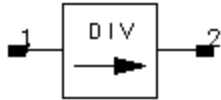

Available in ADS and RFDE

Parameters

Name	Description	Units	Default
FnomIn	Nominal input frequency	kHz	1.0
N	Divide number	None	11

Notes/Equations

- This model performs a divide-by-N function on either a baseband-input or a selected-carrier input frequency. The model operates in transient, harmonic balance, or circuit envelope simulation.
In transient, all signals are considered baseband.
In circuit envelope, the FnomIn parameter defines which analysis frequency to use. If the analysis frequency is not within $\pm 0.5/\text{timestep}$, a warning is issued and 0 Hz will be used for the analysis frequency.
- The input impedance is infinite. The output impedance fixed at 1 Ohm. If the output is in baseband mode, then its open circuit voltage is equal to the phase of the divided signal in radians. This results in a sawtooth waveform for a CW input. A sawtooth is output (instead of a square wave) to allow for the calculation of the actual frequency from the slope and for the accurate detection of zero crossings without the sampling jitter that would be introduced by the fixed rate sampling of a square wave. If the output is not in baseband mode, then the open circuit voltage is a 1V complex sinusoid at the divided frequency. Whether or not the output is in baseband is determined, in Circuit Envelope mode, by determining the carrier frequency, possibly dc, that is closest to FnomIn; if none are close enough, a warning is issued.
- In non-baseband mode of operation, the divider works by directly extracting the phase of the complex input. The delay of DivideByN = $\max(\text{timestep}, N/(2 \times \text{Fin}))$, where Fin is the actual analysis frequency corresponding to FnomIn.
In baseband mode of operation, the period of the input is determined by detecting when the baseband signal rises through the 0.5V threshold. From this period information, the phase of the divided signal is calculated. For a more standard counter model, see the counter model under probes.
- [Divider with an RF Carrier Input](#) show examples of the divider operating with an RF carrier input: one divider

outputs a baseband output; one divider outputs the divided frequency at the other carrier frequency. Note that N can be time varying in order to simulate the effect of a fractional-N divider. [Output Waveforms](#) shows the simulation results.

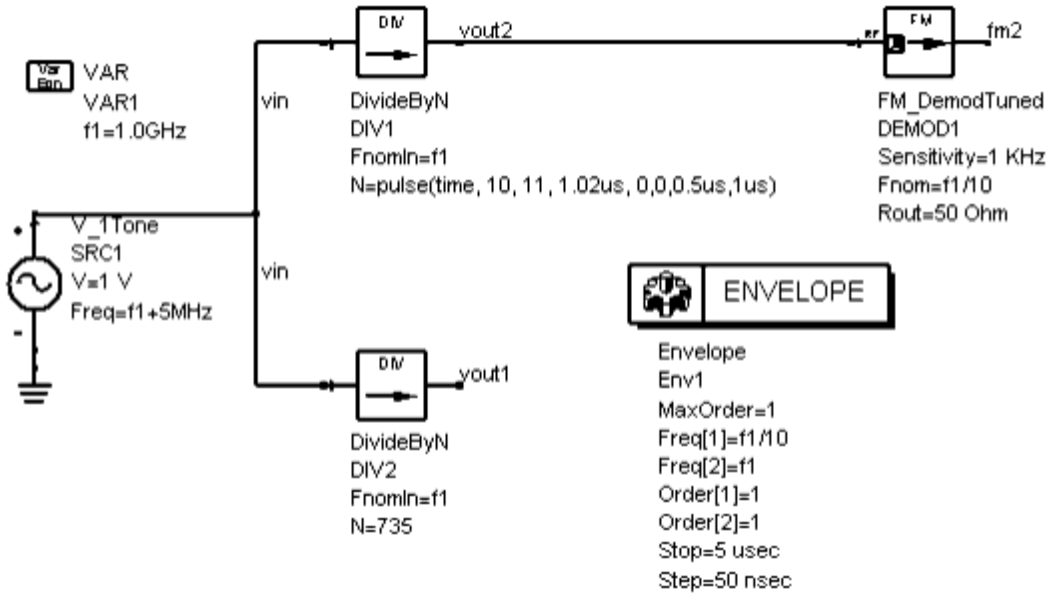

Divider with an RF Carrier Input

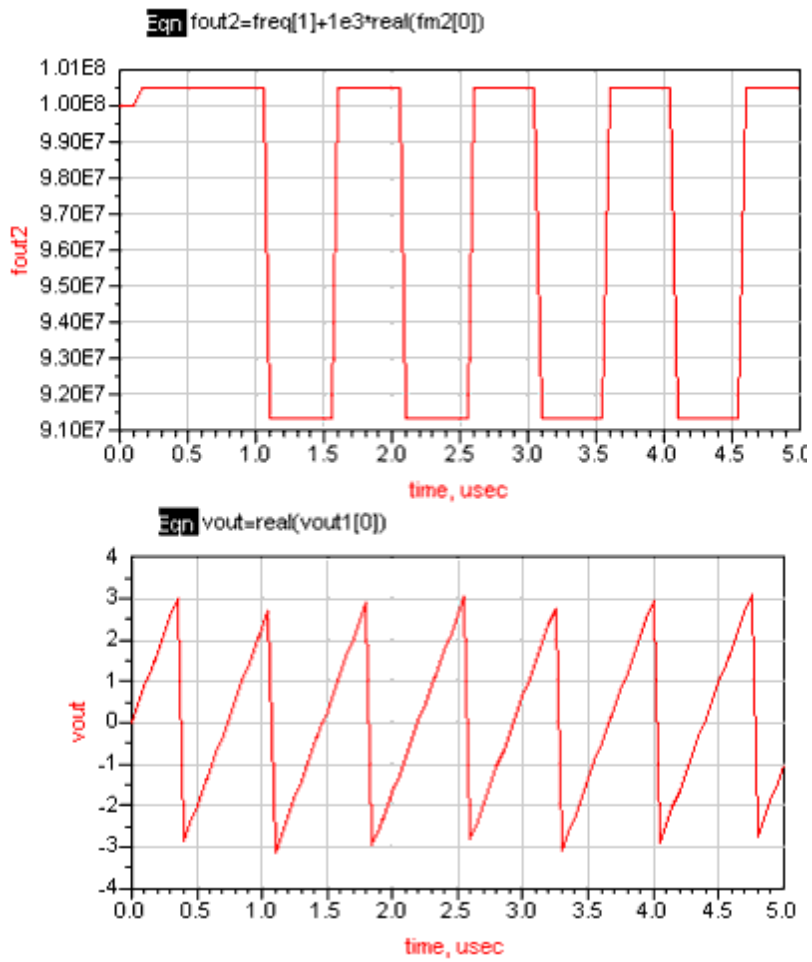

Output Waveforms

PhaseFreqDet (Frequency Detector, Baseband)

Symbol

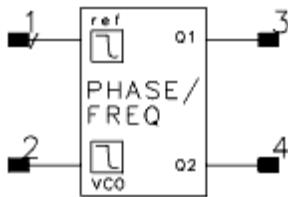

Available in ADS

Parameters

Name	Description	Units	Default
Vhigh	High-state output voltage		
Vlow	Low-state output voltage		

Notes/Equations

1. PhaseFreqDet is not selectable from the component palette or component library browser; to place this component, type its exact name into the Component History box above the drawing area, then move your cursor to the drawing area.
2. This baseband phase-frequency demodulator is used in transient or circuit envelope simulation. It models the digital behavior of common D flip-flop type phase-frequency detectors often used in phase-locked loops. The two outputs are ideal, zero impedance voltage sources; to model a pulsed current-source output, two VDCS-dependent sources must be added to the output of this model. The two inputs have infinite impedance, and only the baseband portion of the two input voltages are used to determine threshold-crossing timing.
3. As opposed to the tuned phase-frequency detector model, this model's output includes the effect of reference clock feed-through.

i Note The output of this model is a pulse train whose average value is proportional to the input phase difference, and may contain significant signal energy at the reference clock rate and at clock harmonics. These must be filtered out, typically before driving a VCO in a PLL application. The tuned phase-frequency detector output signal includes the instantaneous phase difference information only; it does not contain reference frequency or harmonic content.

However, the penalty for this is that the timestep must be less than one-half the reference period, and typically less than one-tenth the period. To avoid the large amount of time jitter and phase noise that would normally be introduced by sampling at even these rates, the two digital outputs are also amplitude modulated to reflect the portion of a simulation timestep where the actual outputs would be high or low. For example, if based on the threshold-crossing timing (the pulse width should be 10 nsec, but the simulation timestep is 1 μ), then the output amplitude for that timestep would only be 1% of the Vhigh level. While this will not properly model all the higher harmonics of the reference feed-through, it does accurately model both the dc term and the first few harmonics,

and the corresponding reference sidebands of the VCO. As the analysis timestep is further reduced, the behavior becomes more truly digital in nature and more harmonics are effectively being simulated at the cost of slower simulations.

4. The trigger times for both inputs is determined by detecting when the baseband voltage rises through the 0.5V threshold. Linear interpolation is used to get much finer time resolution than the analysis timestep. To further reduce excessive sampling jitter, the inputs to this detector can be sawtooth waveforms. While the detector will work reasonably well with sinusoidal inputs, given a small enough timestep, timing jitter can be eliminated if the interpolation is done on the positive slope of a sawtooth waveform. This is the reason why the divide-by-N models output a sawtooth waveform when they operate in the baseband mode. Square-wave inputs should generally be avoided, because this will usually introduce significant timing jitter and phase noise into the simulation.
5. This model does not include any effects due to the finite duration of the flip-flop reset pulse and resultant zero-phase dead zone. Other effects, such as asymmetry between the two different outputs, can be incorporated by changing the external components. [PhaseFreqDet Example](#) shows an example using this detector; [Output Waveforms](#) shows the output waveforms.

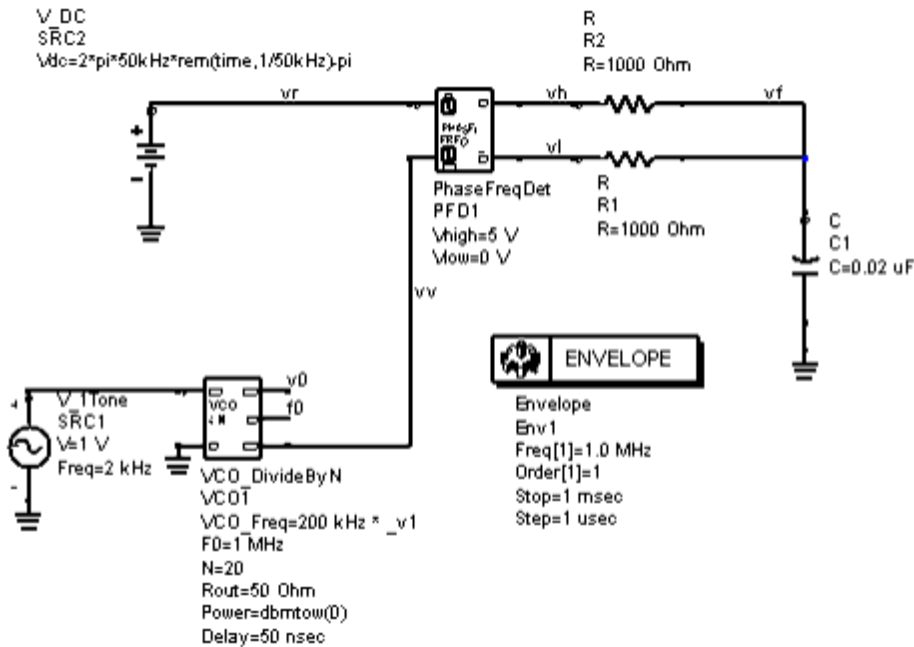

PhaseFreqDet Example

Eqn $v_{out} = \text{real}(vf[0])$
 Eqn $v_{high} = \text{real}(vh[0])$
 Eqn $v_{low} = \text{real}(vl[0])$
 Eqn $v_{ref} = \text{real}(vr[0])$
 Eqn $v_{vcon} = \text{real}(w[0])$

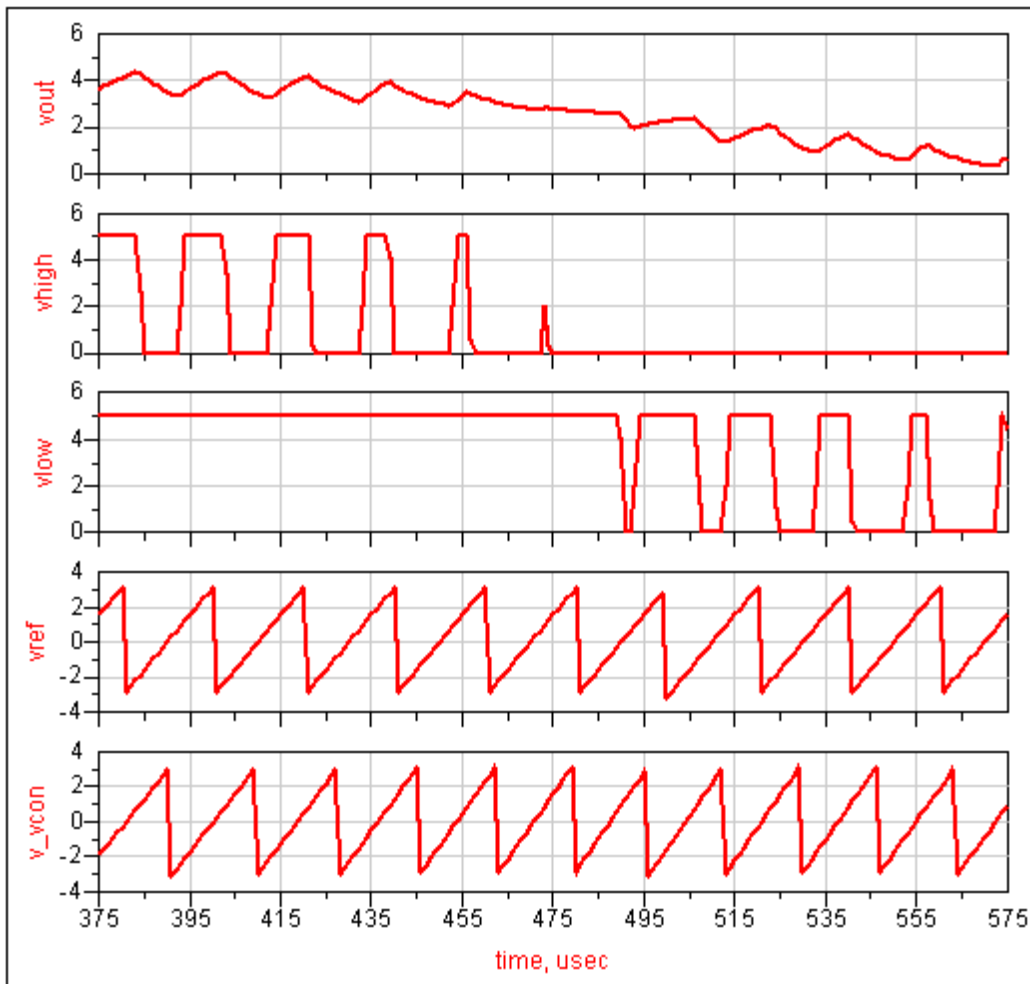

Output Waveforms

PhaseFreqDet2 (Frequency Detector, Baseband)

Symbol

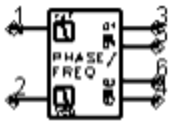

Available in ADS and RFDE

Parameters

Name	Description	Units	Default
Vhigh	High-state output voltage	V	5
Vlow	Low-state output voltage	V	0
DeadTime	Dead zone pulse width	psec	0
Jitter	Input time jitter	psec	0

Notes/Equations

1. This baseband phase-frequency demodulator is used in transient or circuit envelope simulation. It models the digital behavior of common D flip-flop type phase-frequency detectors often used in phase-locked loops. The four outputs are ideal, zero impedance voltage sources. The two inputs have infinite impedance, and only the baseband portion of the two input voltages are used to determine threshold-crossing timing.

2. The following FDD modeling equations illustrate how the shape of the four outputs relate to the input phase difference.

The phase difference between the input on port 1 and port 2 is calculated as

$ns = _phase_freq(1,2)$, and the quantities $n1 = (Vhigh - Vlow) \times real(ns)$ and

$n2 = (Vhigh - Vlow) \times imag(ns)$ are introduced.

Outputs on ports 3-6 are then

port 3: $Q1 = Vlow + n1$

port 4: $Q2_bar = Vhigh - n2$

port 5: $Q1_bar = Vhigh - n1$ (only PhaseFreqDet2, not PhaseFreqDet)

port 6: $Q2 = Vlow + n2$ (only PhaseFreqDet2, not PhaseFreqDet)

with the following trigger events:

Trig[1] = $_xcross(1,0.5,1)$

Trig[2] = $_xcross(3,0.5,1)$

For details about these functions, refer to the FDD device documentation in the Circuit Components Nonlinear Devices manual.

Note that you can push into the component to see the implementation of the component.

3. As opposed to the tuned phase-frequency detector model, this model's output includes reference clock

feed-through effects.

Note The output of this model is a pulse train whose average value is proportional to the input phase difference, and may contain significant signal energy at the reference clock rate, and at clock harmonics. Typically, these must be filtered out before driving a VCO in a PLL application. The tuned phase-frequency detector output signal includes instantaneous phase difference information only (it does not contain reference frequency or harmonic content).

However, the penalty for this is that the timestep must be less than one-half the reference period, and typically less than one-tenth the period. To avoid the large amount of time jitter and phase noise that would normally be introduced by sampling at even these rates, the four digital outputs are also amplitude modulated to reflect the portion of a simulation timestep where the actual outputs would be high or low. For example, if based on the threshold-crossing timing (the pulse width should be 10 nsec, but the simulation timestep is 1 μ), then the output amplitude for that timestep would only be 1% of the V_{high} level. While this will not properly model all the higher harmonics of the reference feed-through, it does accurately model both the dc term and the first few harmonics, and the corresponding reference sidebands of the VCO. As the analysis timestep is further reduced, the behavior becomes more truly digital in nature and more harmonics are effectively being simulated at the cost of slower simulations.

4. The trigger times for both inputs is determined by detecting when the baseband voltage rises through the 0.5V threshold. Linear interpolation is used to get much finer time resolution than the analysis timestep. To further reduce excessive sampling jitter, inputs to this detector can be sawtooth waveforms. While the detector will work reasonably well with sinusoidal inputs, given a small enough timestep, the timing jitter can be eliminated if the interpolation is done on the positive slope of a sawtooth waveform. This is the reason why the divide-by-N models output a sawtooth waveform when they operate in the baseband mode. Square wave-inputs should generally be avoided, because this will usually introduce significant timing jitter and phase noise into the simulation.
5. DeadTime specifies the period of time centered around the 0 phase output during which no output is generated from either the high or the low charge pump. Outside of this period, the output returns to the ideal pulse widths and amplitudes determined by the trigger crossings of the inputs and the charge pump currents.
6. The Jitter value defines the RMS time jitter associated with a trigger crossing on either input. The distribution is Gaussian and the noise spectrum is assumed flat out to the reference sampling frequency.
7. Other effects, such as asymmetry between the four different outputs, can be incorporated by changing the external components. [One application of detector](#) shows one application of this detector and [Resultant output waveforms of detector](#) the resultant output waveforms.

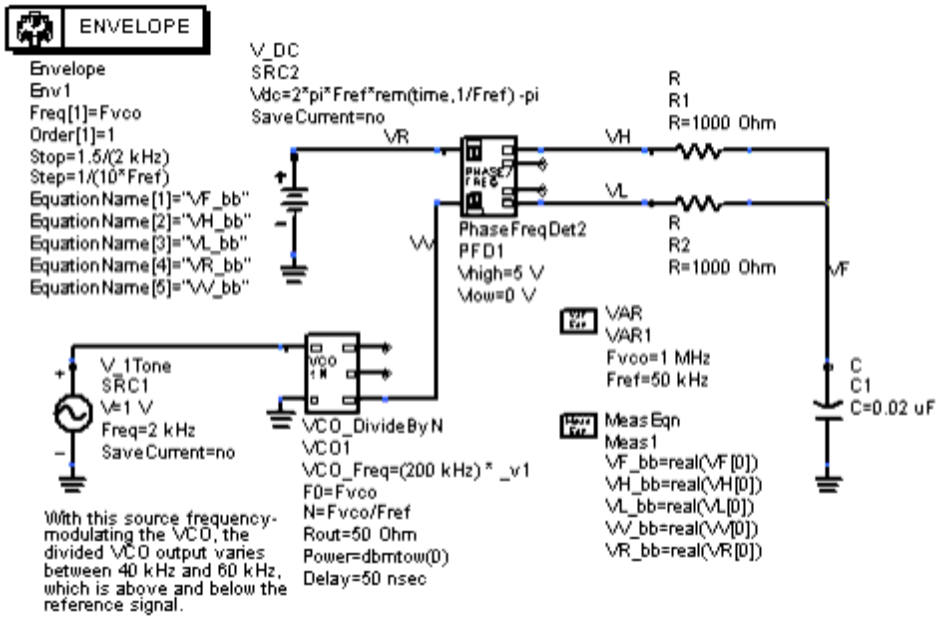

One application of detector

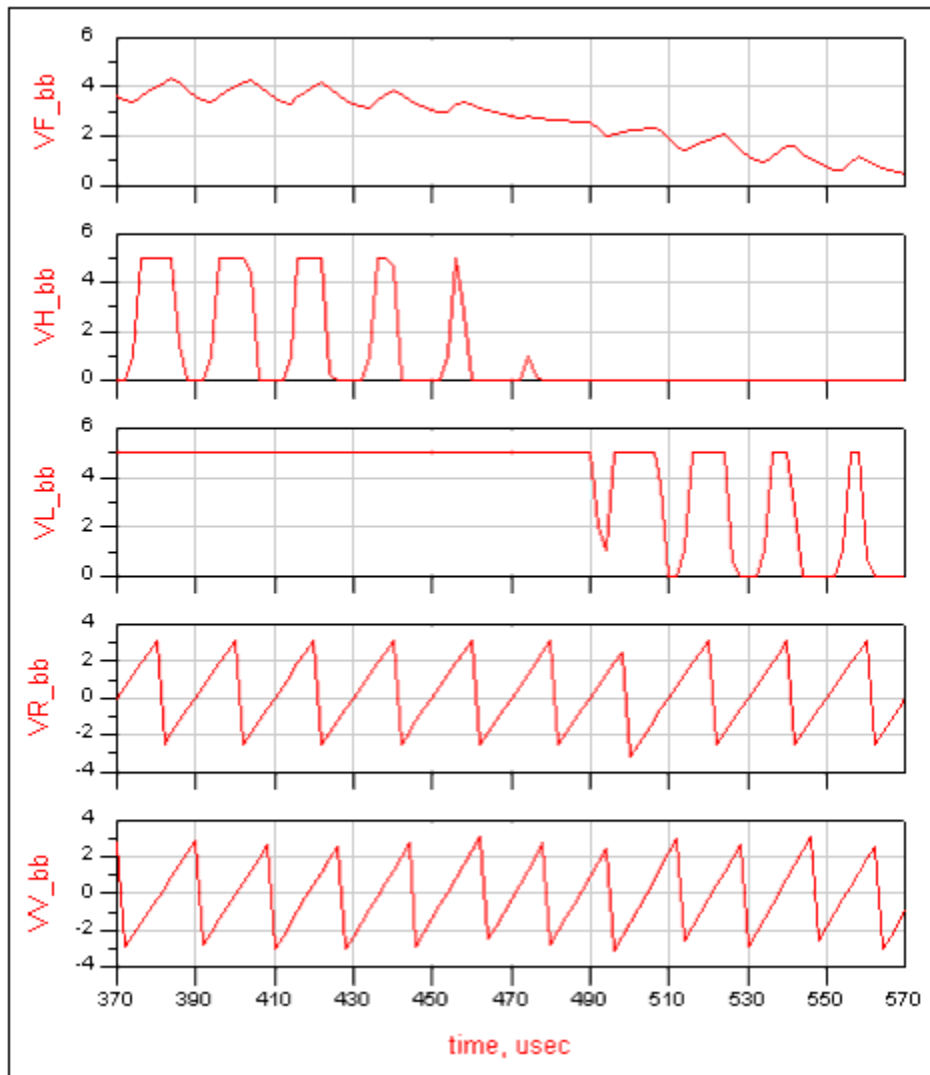

Resultant output waveforms of detector

PhaseFreqDetCP (Frequency Detector, Baseband with Charge Pump)

Symbol

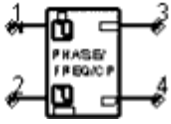

Available in ADS and RFDE

Parameters

Name	Description	Units	Default
Ihigh	High-level charge pump current	mA	1
Ilow	Low-level charge pump current	mA	1
DeadTime	Dead-zone pulse width	psec	0
Jitter	Input time jitter	psec	0

Notes/Equations

1. This baseband phase-frequency demodulator with charge pump is used in transient or circuit envelope simulation.
2. Charge pump currents can be constants (in which case they are ideal current sources) or functions of the state variable `_v2` to allow for a non-ideal current whose peak value varies as a function of the output voltages. In either case, the off-state current is always 0.0. Normally positive values would be used for both currents, as Ihigh specifies a source current and Ilow specifies the sink current.
3. DeadTime specifies the period of time centered around the 0 phase output during which no output is generated from either the high or the low charge pump. Outside of this period, the output returns to the ideal pulse widths and amplitudes determined by the trigger crossings of the inputs and the charge pump currents.
4. The Jitter value defines the RMS time jitter associated with the trigger crossing at each of the two inputs. The effective output time jitter will be $\sqrt{2}$ times this value. The distribution is Gaussian and the noise spectrum is assumed flat out to the reference sampling frequency.

PhaseFreqDetTuned (Phase Frequency Detector, Tuned)

Symbol



Available in ADS and RFDE

Parameters

Name	Description	Units	Default
Sensitivity	Detector sensitivity (mA/degree)	None	0.1
MaxAngle	Maximum unwrapped phase angle (+/- MaxAngle)	deg	360
Vlimit	Maximum output voltage compliance (+/- Vlimit)	V	20
Fnom	Nominal input frequency for VCO and REF inputs	kHz	100

Notes/Equations

- This tuned phase-frequency demodulator is used with circuit envelope simulation that models the ideal behavior of the phase frequency detectors used in phase-locked loops. (This model does not work with transient simulation.)
 On the REF and the VCO inputs, it selects the input carrier closest to the specified Fnom frequency. For proper operation, this cannot be the baseband (dc) envelope. It then generates a baseband output signal equal to the phase difference between the VCO and REF inputs, with an offset of $2 \times \pi \times \Delta f \times \text{time}$ being generated if there is a frequency difference Δf between the two inputs.
 As an example consider the sources
 $V_1(t) = \exp(j \times P_1(t))$ at f_0 and
 $V_2(t) = \exp(j \times P_2(t))$ also at f_0 ,
 as input to a PhaseFreqDetTuned component with the output terminated in a high impedance.

i NOTE $P_n(t)$ is a function that is defined by phase or a phase descriptor.

Envelope simulation at f_0 yields a DC output with a $P_1(t) - P_2(t)$ time dependence. Changing the frequency

of the second source from f_0 to $f_0 + \Delta f$ for the same $V_2(t)$ is equivalent with keeping the frequency at f_0 but multiplying $V_2(t)$ by $\exp(j \times 2 \times \pi \times \Delta f \times t)$ and results in the output signal $P_1(t) - P_2(t) - (2 \times \pi \times \Delta f \times t)$.

If there is no analysis harmonic frequency close enough to the F_{nom} frequency, then a warning is generated. The two input impedances are infinite. The output is a baseband-only infinite impedance current source with scaling defined by the Sensitivity parameter. If the output voltage exceeds V_{limit} or is lower than $-V_{limit}$, then a voltage limiter with an impedance of 10 Ohms is switched in.

The MaxAngle parameter can be used to model special phase-frequency detectors that have greater than the traditional $\pm 2\pi$ of input phase range.

- This model does not model any of the reference or VCO frequency components on the output. The output is a baseband-only signal, and the voltage limiting applies to the baseband component only. (See the baseband phase-frequency detector for a model that can overcome this limitation.) With this tuned model, though, the timesteps can actually be larger than the reference period, and it is only dependent on the PLL bandwidth and not the reference frequency; this enables faster performance for many types of simulation measurements. Another limitation is that only the phase of the selected input envelope is included. The effect of additional input spurs and harmonics are not included if they are in different carrier frequency envelopes.
- [Phase-Frequency Detector Example](#) and [Simulation Results](#) show a simple schematic and example of this phase-frequency detector's output. The reference input is a fixed frequency. The VCO input has sinusoidal frequency modulation.

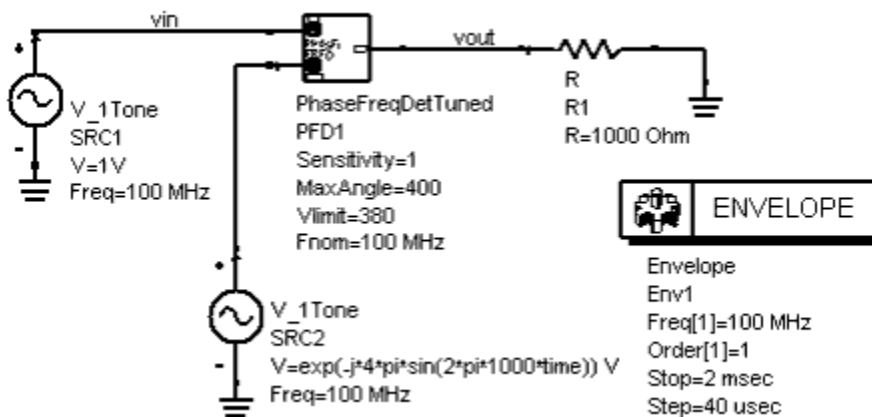

Phase-Frequency Detector Example

Eqn Vout1=real(vout[0])

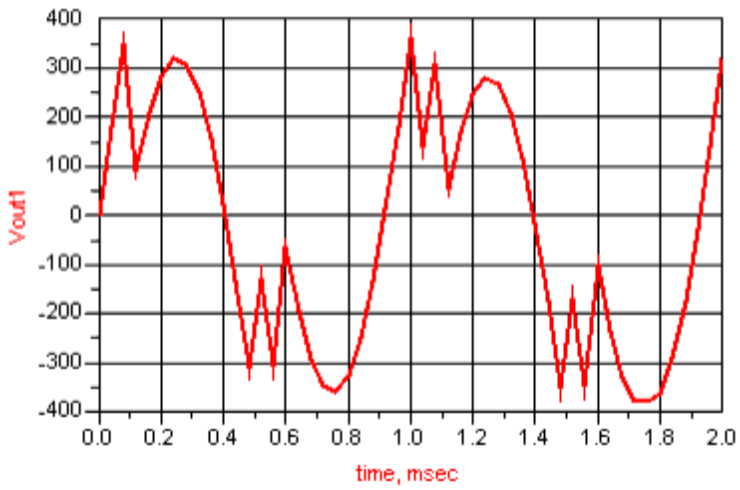

Simulation Results

PhaseNoiseMod (Phase Noise Modulator)

Symbol



Available in ADS and RFDE

Parameters

Name	Description	Units	Default
Fnom	Nominal input frequency	GHz	1
Rout	Output resistance	Ohm	50
Fcorner	Corner frequency for 1/f noise performance	MHz	1
NF	Broadband noise figure	dB	3
QL	Loaded Q of resonator	None	500

Notes/Equations

- This device uses Leeson's equation to model oscillator phase noise, then modulates the input carrier with this phase noise.
The input can be from any signal source, including the VCO models. This model behaves as a tuned modulator by selecting and modulating just the carrier defined by the Fnom parameter. If there are no analysis frequencies close enough to this value, a warning is generated and no signal is output. The Leeson's equation models the oscillator phase using the equation

$$S_{\Delta\phi} = \frac{(F)kTB}{P_{sig_{AV}}} \times \left(1 + \left(\frac{F_{nom}}{2Q_L Freq}\right)^2\right) \times \left(1 + \frac{F_{corner}}{Freq}\right)$$

where

Fnom is used as an approximation to carrier frequency

F is the noise factor

$$P_{sig_{AV}}$$

is the input signal power

T is the absolute temperature

B is the analysis bandwidth

k is the Boltzmann constant

Q L is the loaded Q value of the oscillator's resonator

Fcorner is the frequency at which the low frequency 1/f noise is equal to the broadband noise.

This model is usable in frequency domain and circuit envelope time domain noise analyses. To avoid the divide-by-zero problems as the analysis offset frequency approaches 0, both the 1/f² and 1/f terms are rolled off at frequencies below 1 Hz. In the time-domain mode, the 1/f frequency response is implemented by doing a convolution simulation. The duration of this impulse response is set to 2000 timesteps. This effectively rolls off this 1/f response at a frequency determined by the analysis tstep parameter.

- This circuit phase modulates one large signal frequency with noise to produce pure phase noise without amplitude noise. Because of the nature of harmonic balance, the noise exists at sidebands above and below this one large signal tone, but around no other large signal frequencies. Thus, if phase noise is specified at an offset frequency large enough that it could appear around another large signal frequency, the noise will not appear if viewed around that other large signal frequency. This can be a limitation when attempting to combine two sources that are close together in frequency. In that case, the P_1Tone with phase noise should be used instead for harmonic balance analysis.

VCO (Voltage Controlled Oscillator)

Symbol



Available in ADS and RFDE

Parameters

Name	Description	Units	Default
Kv	Frequency tuning sensitivity (Hz/Volt)	kHz	1
Freq	Fundamental frequency	GHz	1
P	Power into Rout Load at Fundamental Frequency, complex value	None	$-j \times \text{dbmtow}(0)$
Rout	Output resistance	Ohm	50
Delay	Transit time delay added to input tuning voltage	None	timestep
Harmonics	Ratio of harmonic voltage to fundamental voltage, complex value	None	list(-0.01, 0.002)

Notes/Equations

1. This is a simple VCO model that outputs a signal whose frequency is controlled in a linear manner by the input tuning voltage. The center frequency is defined by the Freq parameter, which references one of the analysis frequencies. A Freq value of 0 references dc and so defines the VCO as a baseband source; the output frequency is the baseband input voltage times the Kv parameter value. Only the baseband portion of the input tuning voltage is used to determine the VCO frequency offset.
2. The phase of the VCO output is clamped when time equals 0, so this model only functions as a VCO in the time-domain analysis modes, including circuit envelope and transient simulation. Because transient simulation is

a baseband-only analysis mode, Freq should be 0 in this mode.

3. The output resistance at all frequencies is set by Rout, which is internally limited to a minimum value of 0.1 Ohm. The VCO's fundamental output power into an Rout load is defined by the P parameter. The relative level, in linear units, of the second and third harmonics are defined by the Harmonics parameter; this parameter can be complex to allow definition of the relative phase of these harmonics. The initial phase for the fundamental frequency output is set to -90 degrees so that a sine waveform is created in baseband mode.
4. A Delay parameter value can also be specified for this VCO model. This puts an additional transit delay between the input tuning voltage and the actual change in the output frequency. A delay of at least one time-step does sometimes result in faster simulation speeds, and can be used to model the time delay inherent in any real VCO. Care should be taken when using the VCO in baseband mode (Freq = 0). If the input voltage is allowed to go negative, the model will generate a negative frequency, and the waveform shape due to the harmonic content will be reversed.

The VCO_DivideByN model also allows the definition of a nonlinear frequency tuning characteristic.

5. [VCO in a circuit envelope simulation](#) shows the use of the VCO in an envelope simulation. The VCO is defined with significant second and third harmonic levels. Simulation results are shown in [Simulation Results](#).



```
Envelope
Env1
Freq[1]=1.0 GHz
Order[1]=0
Stop=500 usec
Step=1 usec
```

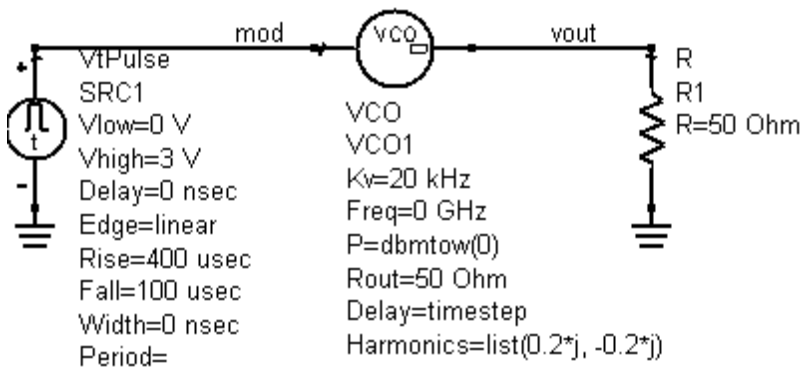

VCO in a circuit envelope simulation

Eqn mod_out=real(mod[0])

Eqn vout_out=real(vout[0])

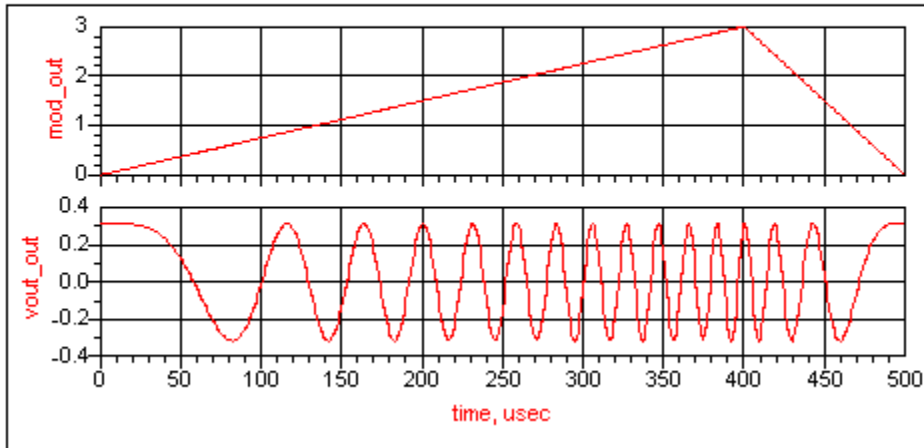

Simulation Results

VCO_DivideByN (VCO Divide By N)

Symbol

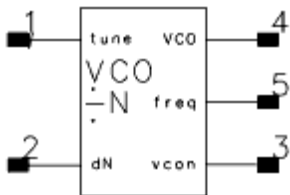

Available in ADS and RFDE

Parameters

Advanced Design System 2008

Name	Description	Units	Default
VCO_Freq	Frequency deviation from F0 (function of _v1)	None	10 MHz × _v1
F0	VCO center frequency	GHz	1
N	Nominal divide number (with dN=0)	None	10
Rout	Output resistance of VCO	Ohm	50
Power	Output power into Rout load	dBm	0
Delay	Transit time delay added to input tuning voltage	nsec	50

Pin Connections

tune connects to a tuning voltage.

dN connects to ground (dN=0) or a voltage source such as V_DC.

dN takes the value of nodal voltage and N+dN becomes the divide ratio.

vcon is the divided-by-(N+dN) output.

freq outputs the undivided frequency values from pin VCO. This pin can be left open.

VCO is the undivided VCO output. This pin can be left open if an undivided VCO is not used.

Notes/Equations

1. This VCO model allows for the definition of an arbitrary, nonlinear frequency tuning characteristic. In addition, it incorporates a behavioral, divide by N model. Incorporating the divider into the same model permits its use in phase-lock loop simulations where the envelope bandwidth, as determined by the analysis time-step, does not have to include the entire tuning range of the VCO, but only the frequency range of the divided output. In these cases, the phase and frequency information of the VCO's main output may be aliased because of the large time-step. But, if just the divided output is being used, the loop simulations will still be valid and can simulate faster due to the large time-step.
As the time-step is decreased, or the range of the VCO is reduced, such that it remains within the envelope bandwidth, then both the main VCO and the divided VCO output are valid. As with the standard VCO model, the phase of this model's outputs are also clamped when time=0 so this model only functions as a VCO in the time-domain analysis modes, including circuit envelope and transient simulations.
2. The frequency of the VCO is determined by the F0 value plus the VCO_Freq value. The VCO_Freq value may be an arbitrary expression using _v1, which is a pre-defined variable representing the input tuning voltage. The frequency is determined inside the model by determining the present value of _v1 (the input voltage), evaluating the VCO_Freq expression and adding this to the F0 value. This frequency is output, as an ideal voltage source scaled to 1V per GHz, on the freq output pin.
3. In circuit envelope simulation, the carrier frequency envelope associated with the main VCO frequency is determined by the F0 value. If there is no analysis harmonic frequency close enough to F0, then a warning is

generated and the main output is zero. The carrier frequency envelope associated with the divided VCO frequency is determined by $F0/N$. Again, if no analysis harmonic frequency is close enough, then a warning is generated and this output is also set to zero.

4. The divide number is determined by adding the N parameter and the dN baseband input voltage. The divide number can change during the simulation. By properly driving the dN input, fractional frequency division can be simulated. To simulate all the dynamics of a fractional divider, the simulation time-step must be small enough to properly digitize the varying divide- or pulse-swallowing rate. Alternatively, either the N value or the dN input can be set to fractional values to obtain a steady-state, fractional division that would not include the switching dynamics and spurs. In circuit envelope simulation, the divided VCO frequency must remain within its initial envelope bandwidth for all combinations of VCO frequencies and divide numbers. It will not automatically jump from one envelope carrier frequency to another. In transient simulation, because everything is treated as baseband signals, the only constraint is that the time-step must be small enough to cover the maximum frequency.
5. Both the main VCO output and the divided output have an output resistance set by the Rout parameter. The main VCO output will deliver the specified Power into a Rout load. The divided output will also deliver this amount of power if it is not a baseband output. If it is a baseband output, then the divided output is a sawtooth waveform, whose open circuit voltage represents the instantaneous phase, in radians, of the divided signal. In transient simulation, then, this divided output is always a sawtooth. In circuit envelope, it is a sawtooth if $F0/N$ is within the baseband envelope (it is less than $0.5/\text{timestep}$). If $F0/N$ is closer to one of the analysis carrier frequencies, then the output is a complex sinusoid with the same amplitude as the main VCO output.
6. A Delay parameter value can also be specified for this VCO model. This puts an additional transit delay between the input tuning voltage and the actual change in the output frequency. A delay of at least one timestep does sometimes result in slightly faster simulation speeds, and can be used to model the time delay inherent in any real VCO.
7. Care should be taken when using the VCO in baseband mode. If $F0+\text{VCO_Freq}$ value goes negative, the model will generate a negative frequency, which may give unexpected results. If this is a problem, the VCO_Freq expression could include a limiting operator to prevent this.
8. [Example with Linear Tuning Characteristics](#) shows an example application; simulation results are shown in [Simulation Results](#). The tuning characteristic is linear in this case and is simply 1 MHz per volt. The nominally divided output frequency is $100\text{MHz}/55=1.81818$ MHz, so this output can be a baseband output, given the 0.1μ timestep. The divide number changes from 95 to 55 halfway through the simulation. (Note that while the divided VCO output may not appear to be a regular, uniform, amplitude sawtooth waveform, it does accurately represent the divided signal's phase.)
9. The frequency can be determined by calculating the phase slope; by using linear interpolation, the baseband phase frequency detectors can accurately determine threshold crossings.

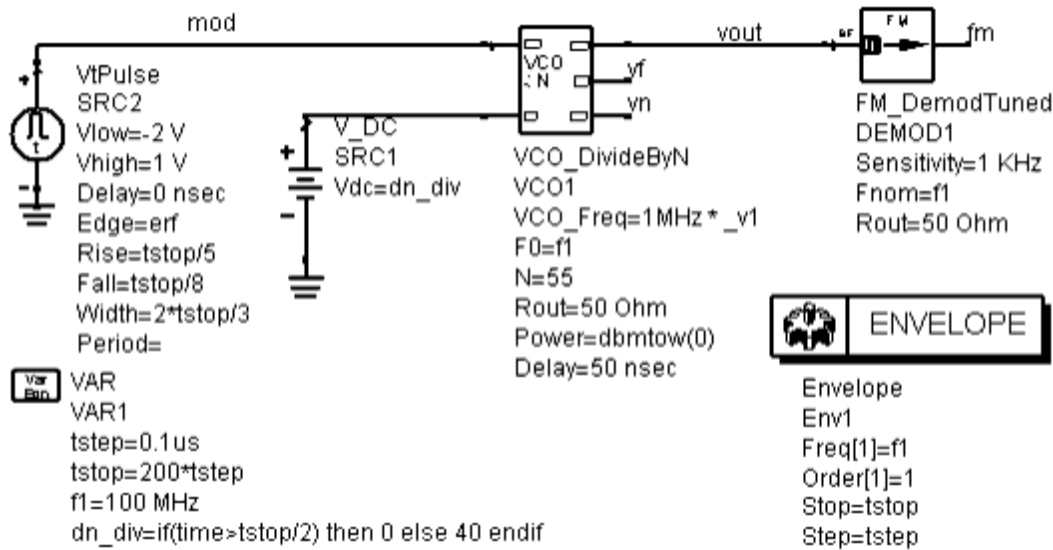

Example with Linear Tuning Characteristics

Eqn vn_out=real(vn[0])

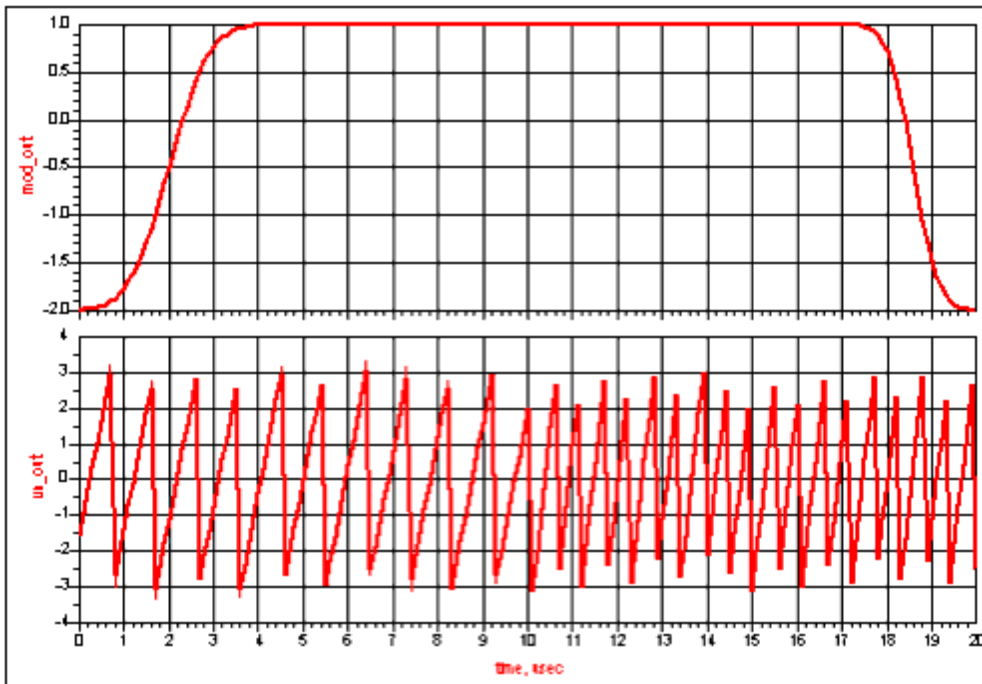

Simulation Results

Switch and Algorithmic Components

Comparator (Comparator)

Symbol

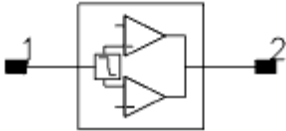

Available in ADS

Parameters

Name	Description	Units	Default
Vlow	Lower threshold voltage	V	0.25
Vhigh	Upper threshold voltage	V	0.75

Notes/Equations

1. Comparator outputs a 1V signal whenever the baseband portion of the input signal is between the two threshold voltages. Input impedance is infinite; output impedance is fixed at 0.1 Ohm; and, there is a fixed delay of one timestep.
2. If the baseband portion of V_{in} is greater than V_{low} and less than V_{high} , then the output voltage at the next time sample is 1.0V; otherwise, the output is 0.0V.
3. This model works in transient and circuit envelope simulation.

ClockLFSR (Linear Feedback Shift Register)

Symbol



Available in ADS

Parameters

Name	Description	Units	Default
Vlow	Lower threshold voltage	V	0.25
Vhigh	Upper threshold voltage	V	0.75
Taps	Bits used to generate feedback	None	bin("10000100")
Seed	Initial value loaded into shift register	None	bin("10101010")
Rout	Output resistance	Ohm	1

Notes/Equations

1. ClockLFSR can be used to generate PN sequences with user-defined recurrence relations. The input is a clock signal; with each positive clock edge, the next output bit is calculated. A clock edge occurs any time the baseband input signal rises through 0.5V.
2. This model works in transient and circuit envelope simulation.
3. With each positive clock edge, data is shifted to the right in the shift register. The length of the shift register is determined by the most significant one-bit in the Taps value.

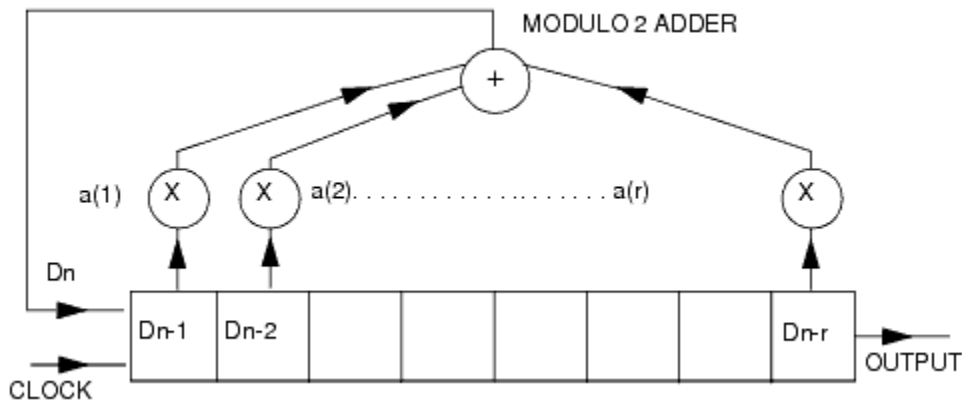

LFSR Model

The numbers $a(1), a(2), \dots, a(r)$ are the binary feedback coefficients and are specified by the Taps parameter. This value may be specified as a decimal number, or as a binary pattern if the $\text{bin}()$ function is used. The initial contents of the shift are specified by the value of the Seed parameter. The following equations describe the operation of this component:

At each positive clock edge n ($n \geq 1$),
for $n \geq 1$:

$$D(n) = \left[\sum_{k=1}^r a(k)D(n-k) \right] \text{mod } 2$$

where

$D(0) = \text{Seed}_2(0)$
 $D(-1) = \text{Seed}_2(1)$

·
·
·

$D(1-r) = \text{Seed}_2(r-1)$

and $\text{Seed} = \sum_{k > 0} \text{Seed}_2(k) 2^k$

where $\text{Seed}_2(k) \in \{0,1\}$ for $0 \leq k < r$.

Example: Let $\text{Seed} = 2$, and $\text{Taps} = 7$

then

$\text{Seed}_2(0) = 0$

$\text{Seed}_2(1) = 1$

·
·
·

$\text{Seed}_2(6) = 0$

thus,

Advanced Design System 2008

$D(0) = \text{Seed2}(0) = 0$
 $D(-1) = \text{Seed2}(1) = 1$
 $D(-2) = \text{Seed2}(2) = 0$

.
.
.

$D(-6) = \text{Seed22}(6) = 0$
 $\text{Seed2}(2) = 0$

Linear Feedback Shift Register ClockLFSR

The binary feedback coefficients are specified by Taps. For example, the recurrence relation

$$D(n) = (D(n-7) + D(n-3) + D(n-2) + D(n-1)) \bmod 2$$

is specified by:

Taps = bin("1000111")

or

Taps = 71

The following table provides a list of feedback coefficients for linear feedback shift registers showing one or more alternate feedback connections for a given number of stages.

Feedback Connections for Linear m-Sequences*

No. of Stages	Code Length	Maximal Taps
2	3	[2, 1]
3	7	[3, 1]
4	15	[4, 1]
5	31	[5, 2] [5, 4, 3, 2] [5, 4, 2, 1]
6	63	[6, 1] [6, 5, 2, 1,] [6, 5, 3, 2,]
7	127	[7, 1] [7, 3] [7, 3, 2, 1,] [7, 4, 3, 2,] [7, 6, 4, 2] [7, 6, 3, 1] [7, 6, 5, 2] [7, 6, 5, 4, 2, 1] [7, 5, 4, 3, 2, 1]
8	255	[8, 4, 3, 2] [8, 6, 5, 3] [8, 6, 5, 2] [8, 5, 3, 1] [8, 6, 5, 1] [8, 7, 6, 1] [8, 7, 6, 5, 2, 1] [8, 6, 4, 3, 2, 1]
9	511	[9, 4] [9, 6, 4, 3] [9, 8, 5, 4] [9, 8, 4, 1] [9, 5, 3, 2] [9, 8, 6, 5] [9, 8, 7, 2] [9, 6, 5, 4, 2] [9, 7, 6, 4, 3, 1] [9, 8, 7, 6, 5, 3]
10	1023	[10, 3] [10, 8, 3, 2] [10, 4, 3, 1] [10, 8, 5, 1][10, 8, 5, 4] [10, 9, 4, 1] [10, 8, 4, 3] [10, 5, 3, 2] [10, 5, 2, 1] [10, 9, 4, 2]
11	2047	[11, 1] [11, 8, 5, 2] [11, 7, 3, 2] [11, 5, 3, 5] [11, 10, 3, 2] [11, 6, 5, 1] [11, 5, 3, 1] [11, 9, 4, 1] [11, 8,

Advanced Design System 2008

		6, 2] [11, 9, 8, 3]
12	4095	[12, 6, 4, 1] [12, 9, 3, 2] [12, 11, 10, 5, 2, 1] [12, 11, 6, 4, 2, 1] [12, 11, 9, 7, 6, 5] [12, 11, 9, 5, 3, 1] [12, 11, 9, 8, 7, 4] [12, 11, 9, 7, 6, 5] [12, 9, 8, 3, 2, 1] [12, 10, 9, 8, 6, 2]
13	8191	[13, 4, 3, 1] [13, 10, 9, 7, 5, 4] [13, 11, 8, 7, 4, 1] [13, 12, 8, 7, 6, 5] [13, 9, 8, 7, 5, 1] [13, 12, 6, 5, 4, 3] [13, 12, 11, 9, 5, 3] [13, 12, 11, 5, 2, 1] [13, 12, 9, 8, 4, 2] [13, 8, 7, 4, 3, 2]
14	16,383	[14, 12, 2, 1] [14, 13, 4, 2] [14, 13, 11, 9] [14, 10, 6, 1] [14, 11, 6, 1] [14, 12, 11, 1] [14, 6, 4, 2] [14, 11, 9, 6, 5, 2] [14, 13, 6, 5, 3, 1] [14, 13, 12, 8, 4, 1] [14, 8, 7, 6, 4, 2] [14, 10, 6, 5, 4, 1] [14, 13, 12, 7, 6, 3] [14, 13, 11, 10, 8, 3]
15	32,767	[15, 13, 10, 9] [15, 13, 10, 1] [15, 14, 9, 2] [15, 1] [15, 9, 4, 1] [15, 12, 3, 1] [15, 10, 5, 4] [15, 10, 5, 4, 3, 2] [15, 11, 7, 6, 2, 1] [15, 7, 6, 3, 2, 1] [15, 10, 9, 8, 5, 3] [15, 12, 5, 4, 3, 2] [15, 10, 9, 7, 5, 3] [15, 13, 12, 10] [15, 13, 10, 2] [15, 12, 9, 1] [15, 14, 12, 2] [15, 13, 9, 6] [15, 7, 4, 1] [15, 4] [15, 13, 7, 4]
16	65,535	[16, 12, 3, 1] [16, 12, 9, 6] [16, 9, 4, 3] [16, 12, 7, 2] [16, 10, 7, 6] [16, 15, 7, 2] [16, 9, 5, 2] [16, 13, 9, 6] [16, 15, 4, 2] [16, 15, 9, 4]
17	131,071	[17, 3] [17, 3, 2] [17, 7, 4, 3] [17, 16, 3, 1] [17, 12, 6, 3, 2, 1] [17, 8, 7, 6, 4, 3] [17, 11, 8, 6, 4, 2] [17, 9, 8, 6, 4, 1] [17, 16, 14, 10, 3, 2] [17, 12, 11, 8, 5, 2]
18	262, 143	[18, 7] [18, 10, 7, 5] [18, 13, 11, 9, 8, 7, 6, 3] [18, 17, 16, 15, 10, 9, 8, 7] [18, 15, 12, 11, 9, 8, 7, 6]
19	524,287	[19, 5, 2, 1] [19, 13, 8, 5, 4, 3] [19, 12, 10, 9, 7, 3] [19, 17, 15, 14, 13, 12, 6, 1] [19, 17, 15, 14, 13, 9, 8, 4,

Advanced Design System 2008

		2, 1] [19, 16, 13, 11, 19, 9, 4, 1] [19, 9, 8, 7, 6, 3] [19, 16, 15, 13, 12, 9, 5, 4, 2, 1] [19, 18, 15, 14, 11, 10, 8, 5, 3, 2] [19, 18, 17, 16, 12, 7, 6, 5, 3, 1]
20	1,048,575	[20, 3] [20, 9, 5, 3] [20, 19, 4, 3] [20, 11, 8, 6, 3, 2] [20, 17, 14, 10, 7, 4, 3, 2]
21	2,097,151	[21, 2] [21, 14, 7, 2] [21, 13, 5, 2] [21, 14, 7, 6, 3, 2] [21, 8, 7, 4, 3, 2] [21, 10, 6, 4, 3, 2] [21, 15, 10, 9, 5, 4, 3, 2] [21, 14, 12, 7, 6, 4, 3, 2] [21, 20, 19, 18, 5, 4, 3, 2]
22	4,194,303	[22,1] [22, 9, 5, 1] [22, 20, 18, 16,6, 4, 2, 1] [22, 19, 16, 13, 10, 7, 4, 1] [22, 17, 9, 7, 2, 1] [22, 17, 13, 12, 8, 7, 2, 1] [22, 14, 13, 12, 7, 3, 2, 1]
23	8,388,607	[23, 5] [23, 17, 11, 5] [23, 5, 4, 1] [23, 12, 5, 4] [23, 21, 7, 5] [23, 16, 13, 6, 5, 3] [23, 11, 10, 7, 6, 5] [23, 15, 10, 9, 7, 5, 4, 3] [23, 17, 11, 9, 8, 5, 4, 1] [23, 18, 16, 13, 11, 8, 5, 2]
24	16,777,215	[24, 7, 2] [24, 4, 3, 1] [24, 22, 20, 18, 16, 14, 11, 9, 8, 7, 5, 4] [24, 21, 19, 18, 17, 16, 15, 14, 13, 10, 9, 5, 4, 1]
25	33,554, 431	[25, 3] [25, 3, 2, 1] [25, 20, 5, 3] [25, 12, 5, 4] [25, 17, 10, 3, 2, 1] [25, 23, 21, 19, 9, 7, 5, 3] [25, 18, 12, 11, 6, 5, 4] [25, 20, 16, 11, 5, 3, 2, 1] [25, 12, 11, 8, 7, 6, 4, 3]
26	67,108,863	[26, 6, 2, 1] [26, 22, 21, 16, 12, 11, 10, 8, 5, 4, 3, 1]
27	134,217,727	[27, 5, 2, 1] [27, 18, 11, 10, 9, 5, 4, 3]
28	268,435,455	[28, 3] [28, 13, 11, 9, 5, 3] [28, 22, 11, 10, 4, 3] [28, 24, 20, 16, 12, 8, 4, 3, 2, 1]
29	536,870,911	[29, 2] [29, 20, 11, 2] [29, 13, 7, 2] [29, 21, 5, 2] [29, 26, 5, 2] [29, 19, 16, 6, 3, 2] [29, 18, 14, 6, 3, 2]

30	1,073,741,823	[30, 23, 2, 1] [30, 6, 4, 1] [30, 24, 20, 16, 14, 13, 11, 7, 2, 1]
31	2,147,483,647	[31, 29, 21, 17] [31, 28, 19, 15] [31, 3] [31, 3, 2, 1] [31, 13, 8, 3] [31, 21, 12, 3, 2, 1] [31, 20, 18, 7, 5, 3] [31, 30, 29, 25] [31, 28, 24, 10] [31, 20, 15, 5, 4, 3] [31, 16, 8, 4, 3, 2]
32	4,294,967,295	[32, 22, 2, 1] [32, 7, 5, 3, 2, 1] [32, 28, 19, 18, 16, 14, 11, 10, 9, 6, 5, 1]
33	8,589,934,591	[33, 13] [33, 22, 13, 11] [33, 26, 14, 10] [33, 6, 4, 1] [33, 22, 16, 13, 11, 8]
61	2,305,843,009, 213, 693, 951	[61, 5, 2, 1]
89	618,970,019,642,690, 137,449,562,112	[89, 6, 5, 3]

Reprinted by permission of John Wiley & Sons. From Spread Spectrum Systems, 2nd edition, p. 87, Robert C. Dixon. Copyright © 1984 by John Wiley & Sons, Inc.

Differentiator (Differentiator)

Symbol

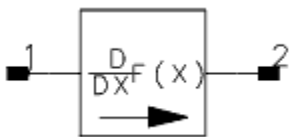

Available in ADS

Parameters

Name	Description	Units	Default
------	-------------	-------	---------

Advanced Design System 2008

Gain	Differentiator slope	None	1
Rref	Reference resistance for both ports	Ohm	50

Notes/Equations

1. The output voltage is equal to the derivative (with respect to time) of the input voltage.
2. The Gain parameter is entered as a linear quantity, not in dB.
3. Differentiator works in both transient and envelope simulations.
4. The input resistance of the integrator is Rref. The output is a voltage source V_{out} in series with output resistance Rref.

DPDT_Static (Double Pole Double Throw Switch, Static)

Symbol

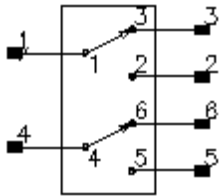

Available in ADS

Parameters

Name	Description	Units	Default
State	State of switch:	None	1
F1	First frequency breakpoint		
F2	Second frequency breakpoint		

Advanced Design System 2008

F3	Third frequency breakpoint		
Loss1	Attenuation for frequency $\leq F1$	dB	0
Loss2	Attenuation for $F1 < \text{frequency} \leq F2$	dB	0
Loss3	Attenuation for $F2 < \text{frequency} \leq F3$	dB	0
Loss4	Attenuation for frequency $> F3$	dB	0
VSWR1	Voltage standing wave ratio at both ports for frequencies $\leq F1$	None	1
VSWR2	Voltage standing wave ratio at both ports for frequencies $> F1, \leq F2$	None	1
VSWR3	Voltage standing wave ratio at both ports for frequencies $> F2, \leq F3$	None	1
VSWR4	Voltage standing wave ratio at both ports for frequencies $> F3$	None	1
Isolat	Isolation	dB	100
ZRef	Reference impedance for all ports	Ohm	50
Temp	Temperature	°C	None

Notes/Equations

1. This model works in transient and circuit envelope simulation.
2. Up to three frequency break points can be used to define four bands, with different losses and VSWR for each frequency band. Losses are entered as a positive attenuation. In other words, a 0.5 dB loss is entered as $L1=0.5$, not $L1=-0.5$.

Isolation is assumed to be constant across all frequency bands.

When using this device in a transient simulation, the switch setting must be constant.

If loss values are specified versus frequency via a dataset and using the component DATASETVARIABLE, then a time delay through the device will be introduced when using transient analysis.

Transient Analysis Time Delay = $(1/(2 \times \text{MAX_FREQUENCY})) \times \text{POINTS}$

where

$\text{POINTS} = (\text{FILTER_ORDER}/2) - 1$ for FILTER_ORDER even

$= (\text{FILTER_ORDER} + 1)/2 - 1$ for FILTER_ORDER odd

IntegratorSML (Integrator)

Symbol

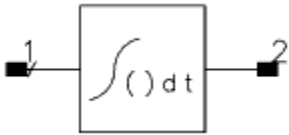

Available in ADS

Parameters

Name	Description	Units	Default
GainAC	Integrator gain	None	1
GainDC	Gain of DC constant	None	1.e6
Rref	Reference resistance for both ports	Ohm	50

Notes/Equations

1. The output voltage is equal to the integral (with respect to time) of the input voltage. This device has been modeled after a physically realizable integrator. The dc gain is not infinite and is specified by GainDC.
2. GainAC is the ac gain of the integrator (typically set to 1.0); GainDC is the dc gain of the integrator. Both of these are a linear quantity, not in dB.
3. An ideal integrator has infinite gain at dc, which is not physically realizable. These parameters describe the operation of the integrator that has been modeled after a traditional high gain differential amplifier with capacitive feedback and a series input resistor. GainDC is the open loop dc gain of the amplifier in this model. Gain is equal to $1/RC$ where R is the input series resistor value in Ohm and C is the feedback capacitor value in farads.
4. The integrator transfer function follows:

$$\frac{V_{out}}{V_{in}} = \frac{GainDC}{1 + (j \times \omega \times GainAC \times GainDC)}$$

where ω is the frequency in radians/sec.

5. IntegratorSML works in both transient and envelope simulations.
6. The input resistance of the integrator is Rref. The output is a voltage source V_{out} in series with output resistance Rref.

LimiterSML (Limiter)

Symbol

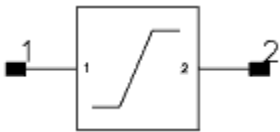

Available in ADS

Parameters

Name	Description	Units	Default
Gain	Linear gain (real only)	None	1.0
Vmax	Maximum output voltage	V	5
Vmin	Minimum output voltage	V	-5
Rout	Output resistance	Ohm	50
Fnom	Nominal input frequency	Hz	0

Range of Usage

$F_{nom} \geq 0$

Notes/Equations

1. The Gain parameter is a real value only (not in dB or complex).
2. This model can be used in transient, harmonic balance and circuit envelope simulations.
3. When used in transient simulations, Fnom must be set to zero. Gain, Vmin and Vmax determine the output voltage time series. The output voltage time series is calculated as Gain times the input voltage time series, but is hard limited to Vmin and Vmax in case the value drops below Vmin or rises above Vmax. Hard limiting is not allowed to reduce the magnitude of the output waveform amplitude by more than a factor of 10^{-4} at any point in time. For example, a sine wave with a 10.6 V amplitude as input to a LimiterSML component with Gain=10, Vmax=1, Vmin=-1, will scale to an output waveform amplitude of 0.3 V, not 1 V. The value 0.3 comes from $10.6 \times \text{Gain} \times 10^{-4}$, where Gain=10 in this example.
4. When used in harmonic balance simulations, Fnom must be set to a non-zero fundamental or intermodulation frequency. Fnom, Gain and abs(Vmax) determines the output voltage spectrum (Vmin is not used). The output voltage spectrum is calculated as Gain times the input voltage spectrum but is scaled by $\min(\text{abs}(\text{Vmax})/\text{abs}(\text{V}(\text{Fnom})), 1)$ at all frequencies, where $\text{V}(\text{Fnom}) = \text{Gain} \times \text{Vin}(\text{Fnom})$. This gain limits the entire frequency spectrum by $\text{abs}(\text{Vmax})/\text{abs}(\text{V}(\text{Fnom}))$ in the case where $\text{abs}(\text{V}(\text{Fnom}))$ exceeds $\text{abs}(\text{Vmax})$. If there is no spectral component at Fnom, no gain limiting is performed. No minimum gain of 10^{-4} applies in this case.
5. When used in circuit envelope simulations, Fnom can be a zero or non-zero fundamental or intermodulation frequency.
 - If Fnom is zero, the mode of operation is similar to that for transient analysis. If there is a baseband signal, it is hard limited as dictated by Vmin and Vmax. Hard limiting is not allowed to drop the magnitude of the output voltage by more than a factor of 10^{-4} at any time (refer to note 3). All other spectral components are scaled accordingly. If there is not a baseband signal, nothing happens.
 - If Fnom is a non-zero fundamental or intermodulation frequency, the mode of operation is similar to that for harmonic balance analysis. All spectral components, including the baseband signal if applicable, are gain limited as dictated by $\min(\text{abs}(\text{Vmax})/\text{abs}(\text{V}(\text{Fnom})), 1)$. For harmonic balance analysis, the value of Vmin does not matter in this case.
6. LimiterSML has more than one mode of operation. It performs clipping or limiting in a Transient or Circuit Envelope analysis, and it performs gain scaling on the spectral components in a Harmonic Balance analysis. Its mode of operation depends on the value of Fnom and the type of simulation being performed.

ParallelSerial (Parallel to Serial Shift Register)

Symbol

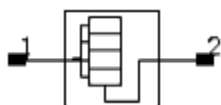

Available in ADS

Parameters

Name	Description	Units	Default
OutputRate	Serial output data clock rate	kHz	50
LSB_First	Select output serial data order:	None	yes
Delay	Initial synchronization delay	nsec	0.0
InputBits	Number of bits in input word	None	4
IntegerIn	Scale input data as integers: yes or no	None	yes

Notes/Equations

1. This Parallel To Serial Shift Register model is used to convert a sequence of input words into a serial output bit stream. The fixed serial output bit rate is specified by the OutputRate parameter. The serial data can be output with either the LSB or MSB first, depending on the state of the LSB_First parameter. The output impedance is fixed at 0.1 Ohm. A logic one generates an open circuit voltage of 1.0V. A logic zero is 0.0V.
2. The number of bits in each input word is specified by InputBits. The input is sampled at a rate equal to OutputRate/InputBits, with an initial synchronization delay specified by Delay.
3. The input impedance is infinite. If the IntegerIn parameter is set true, then the input is assumed to be scaled as an integer from 0.0V to 2 OutputRate –1V. Otherwise, the input is assumed to be scaled from –1.0 to +1.0V, with –1.0V interpreted at word 0.
4. This model works in transient and circuit envelope simulation. Only the baseband portion of circuit envelope voltage is used.

PathSelect2 (Coordinated set of Single Pole Double Throw Static Switches)

Symbol

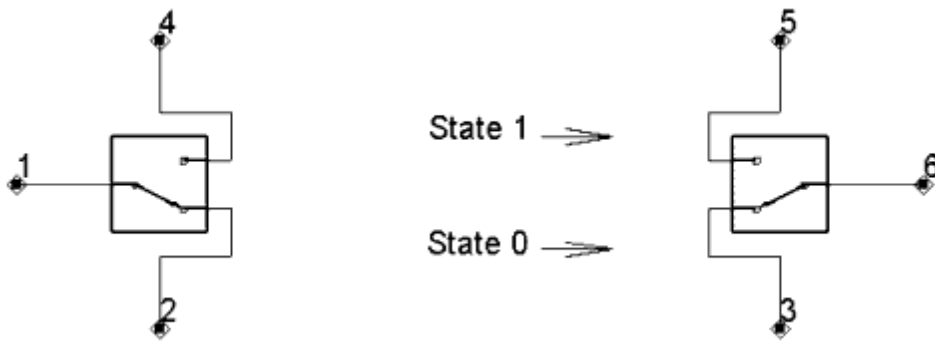

Available in ADS

Parameters

Name	Description	Units	Default
State	State of switch: 0=lower path, 1=upper path	None	0

Notes/Equations

1. This model defines a pair of coordinated static single pole double throw switches that enables connectivity for one of two paths with ideal isolation between the paths.
2. This component uses internal models for SPDT_Static. The schematic design is shown here:

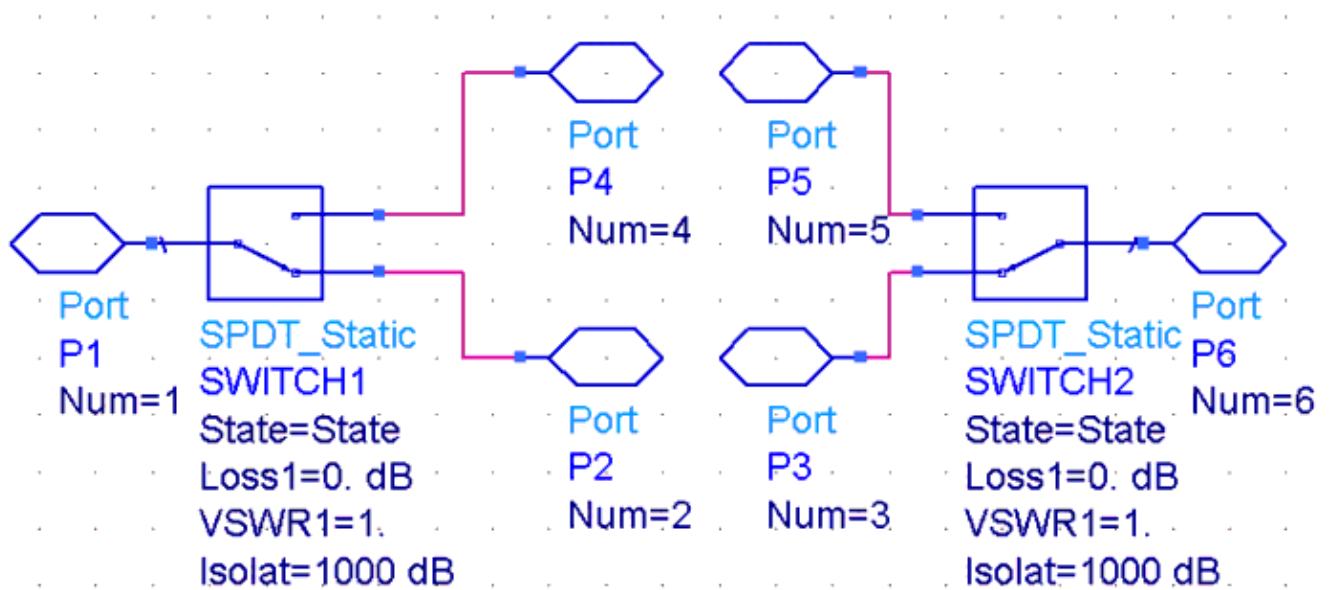

3. When State=0, connectivity occurs from port 1 to port 2 to port 3 to port 6.
4. When State=1, connectivity occurs from port 1 to port 4 to port 5 to port 6.
5. When using this device in a transient simulation, the switch setting must be constant.
6. An example demonstrating this model is located in ADS; access the design from the ADS Main window: File > Example Project > Tutorial > RF_Budget_Examples_prj ; see Budget_Mixer.dsn .

QuantizerSML (Quantizer)

Symbol

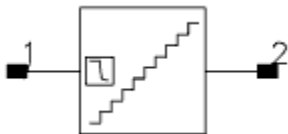

Available in ADS

Parameters

Advanced Design System 2008

Name	Description	Units	Default
Vmin	Minimum baseband input voltage	V	-1.0
Vmax	Maximum baseband input voltage	V	1.0
N	Number of quantized output levels	None	32
OutState	State of output:	None	1
Rout	Output resistance	Ohm	0.1

Notes/Equations

1. This quantizer model outputs a delayed, uniformly quantized representation of the baseband portion of the input voltage. The input impedance is infinite. The delay is fixed at one timestep. The quantization state output mode is in offset binary format.
The input quantization level is equal to $\Delta = (V_{\max} - V_{\min}) / (N - 1)$. Any input less than $(V_{\min} + \Delta / 2)$ is assigned to state 0. Any input greater than $(V_{\max} - \Delta / 2)$ has a state equal to $(N - 1)$. If the OutState parameter is true, this quantization state is directly output. If the OutState parameter is equal to zero, the quantization state is scaled and offset, $V_{\text{out}} = Q/\Delta + V_{\min}$, to match the input voltage.
2. This model works in transient and circuit envelope simulation.
3. An example of using this component along with SampleHoldSML follows.

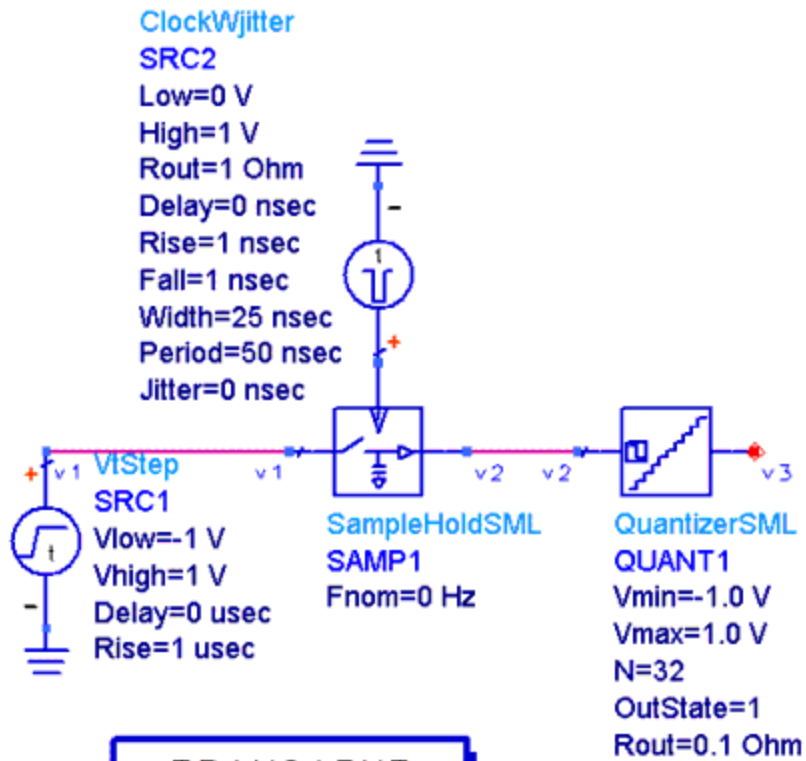

Tran
 Tran1
 StopTime=1 usec
 MaxTimeStep=1 nsec

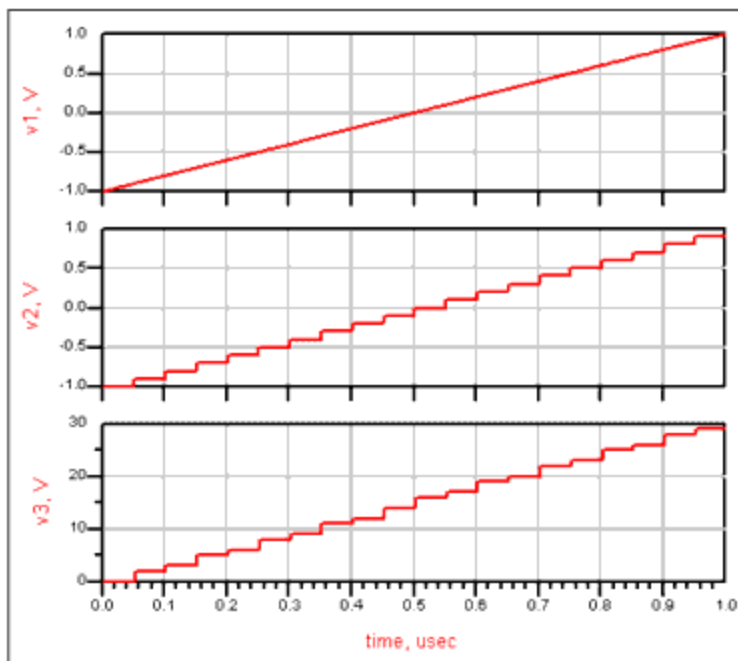

ResetSwitch (Reset Switch)

Symbol

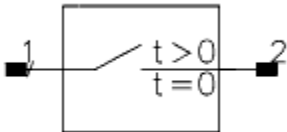

Available in ADS

Parameters

None

Notes/Equations

1. This reset switch is an ideal switch that is closed at time=0 and open for time>0. Its main use is in time domain simulation modes (transient and circuit envelope) to allow the resetting of components such as ideal integrators. Often these blocks that have infinite gain at dc do not allow the circuit simulator to converge, but by keeping them reset at time=0, a valid initial solution can be obtained prior to the actual time domain simulation and then the switch can be opened to observe the time domain response. In steady-state analysis, such as dc or harmonic balance, time is always 0 so this switch remains closed.

SampleHoldSML (Sample Hold)

Symbol

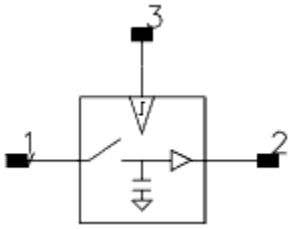

Available in ADS

Parameters

Name	Description	Units	Default
Fnom	Nominal input and output frequency	Hz	0

Notes/Equations

1. This model samples the input signal and holds it until the next sample event. It is a tuned model; it selects and holds just the signal at the input harmonic closest to the frequency specified by Fnom. If there is no analysis harmonic frequency close enough to the Fnom frequency, a warning is issued and the output is 0. The input impedance of both the sample clock input and the signal input is infinite. The output is a voltage source with a fixed impedance of 0.1 Ohm.
2. The sampling instant is defined to be when the sample clock input rises through the 0.5V fixed threshold. If the baseband mode of operation is specified (Fnom ~ 0 Hz), this behaves as a normal sample and hold; the baseband input voltage at the sampling instant is output and then held indefinitely at this constant value until the next sample. If an envelope carrier frequency is specified by Fnom, the signal component at this envelope harmonic frequency is selected and its complex value at the sampling instant is held at the output. This held output appears at the same envelope harmonic frequency. For example, if an envelope analysis with a fundamental of 1 GHz is performed with a timestep of 0.1nsec and an offset frequency source at 1.001 GHz is sampled, the complex value of the envelope is sampled and held constant. The output will appear to be at the 1 GHz fundamental frequency since the complex envelope is no longer changing, until the next sample event.
3. The Sampler model samples the entire spectrum and outputs just a real baseband voltage.
4. SampleHoldSML works in transient and circuit envelope simulation. In transient simulation, Fnom has no effect because all signals are baseband only.

Sampler (Sampler)

Symbol

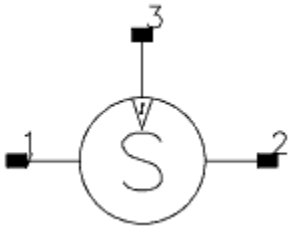

Available in ADS

Parameters

Name	Description	Units	Default
Ton	ON-state pulse width, switch in low impedance state	nsec	1
Ron	ON-state resistance, switch in low impedance state	Ohm	1
S11	Input reflection coefficient	None	0
Z0	Input port characteristic impedance	Ohm	50

Notes/Equations

1. Sampler is a linear behavioral model of a high-frequency sampler. It can also be used to model the sampling efficiency and droop of lower frequency sample-holds.
2. This model works in transient and circuit envelope simulation. In envelope simulation, the input signal is determined by transforming all the spectral input voltages at the sampling instant to determine the total, real instantaneous voltage. Prior to being sampled, the input signal is first filtered with an ideal sinc() filter determined by the Ton pulse width. The input match can be complex, but since it needs to represent a causal response it cannot be complex at dc.
3. The input impedance looking into the sampler is determined by Z0 and S11 with the standard formula:

$$Z_{in} = \frac{Z_0(S_{11} + 1)}{S_{11} - 1}$$

Usually, S11=0 and Z0=50 results in the input impedance of the sampler being 50 Ohms.

4. The Clock/LO input impedance is infinite, and the sampling instant is defined only by the baseband portion of the input signal and occurs whenever the baseband signal passes through 0.5V with a positive slope.

5. Sampler has two basic modes of operation. If R_{on} is equal to 0, then the output is a ideal voltage source with a value equal to the last sampled value of the filtered input voltage; if R_{on} is not equal to 0, then the output impedance is time-varying. In the quiescent state, it is $1T_{ohm}$. However when a sample occurs, the impedance for that time point is reduced to a sampler resistance equal to $R_{on} \times \text{timestep} / T_{on}$. The actual sampler efficiency is then determined by sampler R_{on} and T_{on} values, and the load capacitance on the sampler output. If $T_{on} \gg R_{on} \times C_{Load}$, the sampler will behave with 100% efficiency. In a microwave sampler, this efficiency is typically much less than 100%. The hold time constant in this sampler mode is determined strictly by the capacitive and resistive load placed on the sampler output by the user. The R_{on} sampler parameter should include all charging impedances, including the sampler switch impedance as well as the effect of any source impedance. The output signal in Envelope mode is a baseband-only signal. No RF leakage is included in this model. Note that due to the impulse nature of this sampler model output, the analysis integration order should be set to 1 (Backward Euler) when using this model. This is especially true when sampling rapidly changing input signals and when the sampler parameters are set for high sampling efficiency.
6. In the circuit envelope example in [Circuit Envelope Example, High-Frequency Application](#), the input signal is a high-frequency sawtooth waveform with 15 harmonics. Its frequency is set 10 kHz above 1 GHz. The sampler is being driven at a 500 kHz rate so the output signal should be a replicated sawtooth at 10 kHz. Simulation results for two different combinations of R_{on} and T_{on} are shown in [Simulation Results](#). The high-efficiency mode tracks the input. The low-efficiency mode (50 Ohm, 50 psec) shows its lowpass filtering impact. Note the two different time scales: 2 nsec for the input trace and 200 μ for the output traces.

The example in [Circuit Envelope Example, Low-Frequency Application](#) shows a low-frequency application that has a significant droop due to the finite output resistance. Simulation results are shown in [Simulation Results](#).

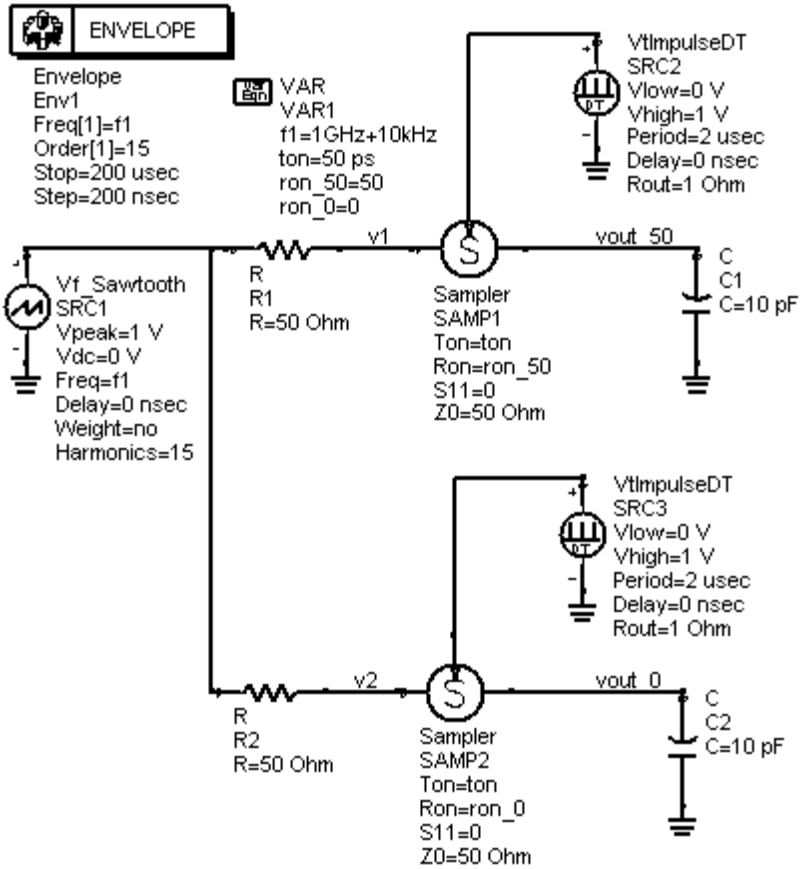

Circuit Envelope Example,

High-Frequency Application

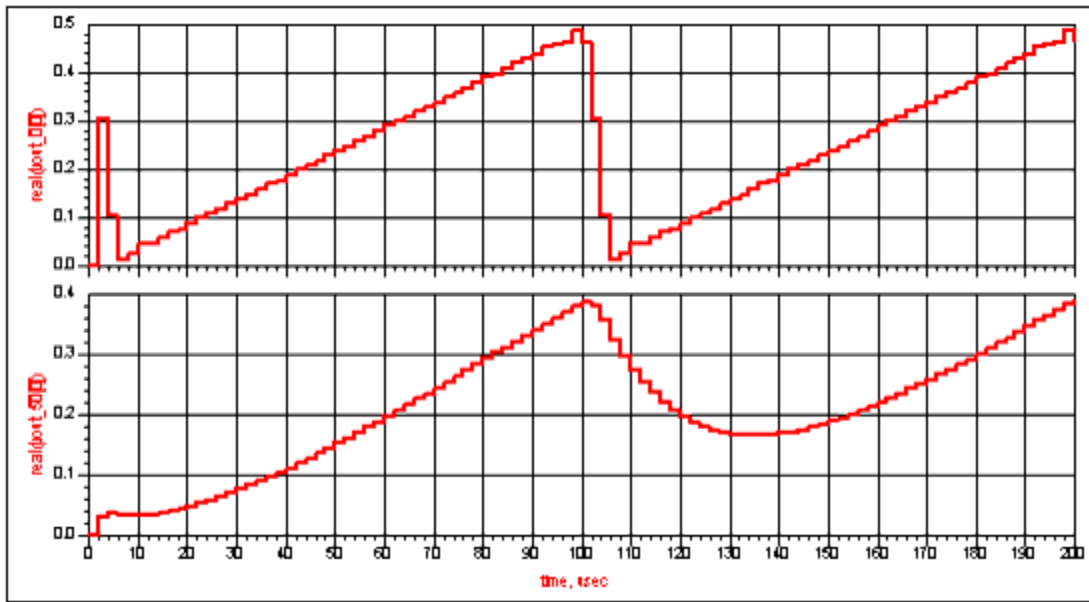

Simulation Results

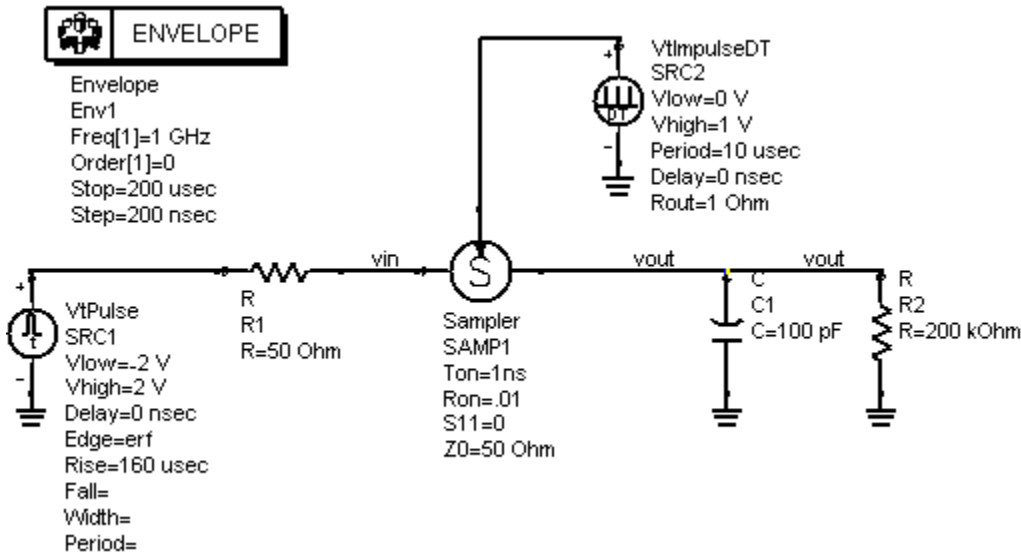

Circuit Envelope Example,

Low-Frequency Application

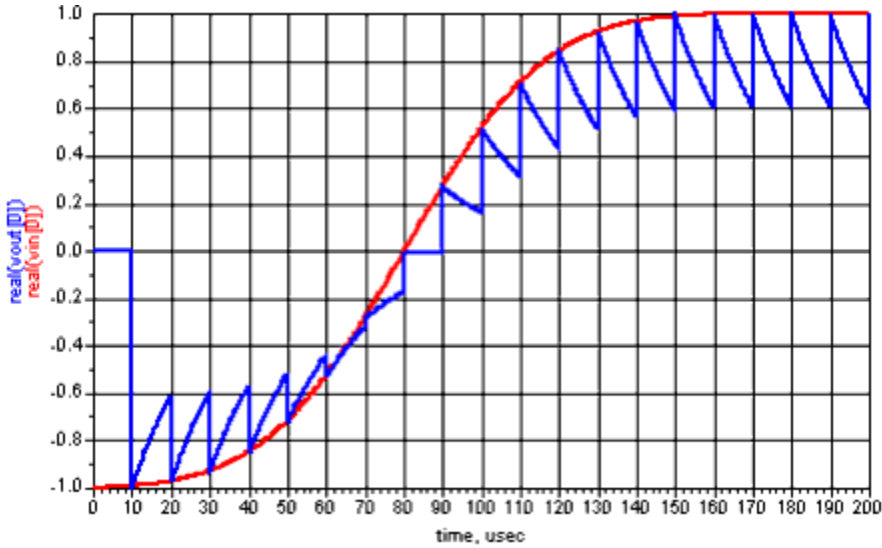

Simulation Results

SerialParallel (Serial to Parallel Shift Register)

Symbol

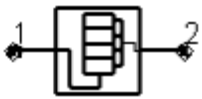

Available in ADS

Parameters

Name	Description	Units	Default
InputRate	Serial input data clock rate	kHz	50
LSB_First	Order of serial data:	None	yes

Delay	Initial synchronization delay	nsec	0.0
OutputBits	Number of bits in output word	None	4
IntegerOut	Scale output data as integers (instead of from -1 to 1): yes or no	None	yes

Notes/Equations

1. This SerialParallel shift register model is used to convert a serial data stream into a multiple bit word. The fixed serial input bit rate is specified by the InputRate parameter, with an initial synchronization delay specified by the Delay parameter. The serial data can be interpreted as either LSB or MSB first, depending on the state of the LSB_First parameter. The input impedance is infinite. A voltage less than 0.5V is a logical zero.
2. The number of bits in each output word is specified by OutputBits. The output is updated at a rate equal to InputRate/OutputBits. The open circuit output voltage is an integer value from 0 to 2 OutputBits -1, if the IntegerOut parameter is true. Otherwise, the output is scaled from a -1 to +1V, with all 0s corresponding to -1V and all 1s to +1Vs. The output impedance is fixed at 0.1 Ohm.
3. This model works in transient and circuit envelope simulation. Only the baseband portion of circuit envelope voltage is used.

SPDT_Dynamic (Single Pole Double Throw Switch, Dynamic)

Symbol

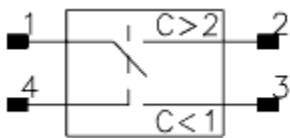

Available in ADS

Parameters

Advanced Design System 2008

Name	Description	Units	Default
Ron	On-state resistance of switch	Ohm	0
Roff	Off-state resistance of switch	GOhm	1

Range of Usage

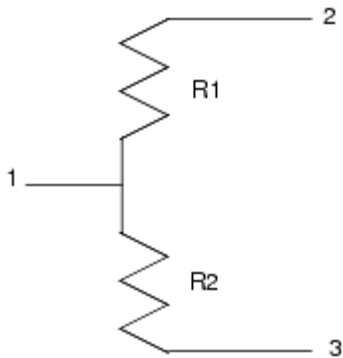

Pin 1 is the input, pins 2 and 3 are output, pin 4 is the control voltage, V_c .

If $V_c > 2V$, $R_1 = R_{on}$, $R_2 = R_{off}$

If $V_c < 1V$, $R_1 = R_{off}$, $R_2 = R_{on}$

When V_c increases from 1V to 1.5V, R_2 changes from R_{on} to R_{off}

When V_c increases from 1.5V to 2V, $R_2 = R_{off}$ and R_1 changes from R_{off} to R_{on}

At $V_c = 1.5V$, $R_1 = R_2 = R_{off}$

Notes/Equations

1. This SPDT_Dynamic switch model, as opposed to the SPDT_Static model, can be used to dynamically switch states in response to the input control voltage. The input impedance of the control voltage port is infinite. Whenever the control voltage is greater than 2.0V, the input is connected to the ($c > 2$) output with a resistance equal to R_{on} ; otherwise, there is a resistance of R_{off} Ohm between the two pins. Similarly, whenever the control voltage is less than 1.0V, the input is connected to the ($c < 1$) output with a resistance of R_{on} ; otherwise, there is a resistance of R_{off} between the two pins. Note that when the control voltage is between 1.0V and 2.0V, the switch is open with respect to both outputs, simulating the break operation before making connection.
2. Capacitances, leakage currents, or other non-idealities are not included in this model.
3. This model is primarily meant for usage in the time domain (transient and circuit envelope) simulation with baseband control voltages. Due to the instantaneous, abrupt nature of the switching action, driving the control input with a carrier frequency input, in either harmonic balance or circuit envelope, should be avoided or done with careful consideration of the number of harmonics required and potential convergence problems.

SPDT_Static (Single Pole Double Throw Switch, Static)

Symbol

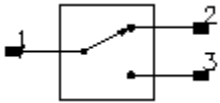

Available in ADS and RFDE

Parameters

Name	Description	Units	Default
State	State of switch: 0=off; 1=on	None	1
F1	First frequency breakpoint		
F2	Second frequency breakpoint		
F3	Third frequency breakpoint		
Loss1	Attenuation for frequencies $\leq F1$	dB	0
Loss2	Attenuation for $F1 <$ frequency $\leq F2$	dB	0
Loss3	Attenuation for $F2 >$ frequency $\leq F3$	dB	0
VSWR1	Voltage standing wave ratio at both ports for frequencies $\leq F1$	None	1
VSWR2	Voltage standing wave ratio at both ports for frequencies $> F1, \leq F2$	None	1

VSWR3	Voltage standing wave ratio at both ports for frequencies $> F2, \leq F3$	None	1
Isolat	Isolation	dB	100
ZRef	reference impedance for all ports	Ohm	50
Temp	temperature	°C	None
CheckPassivity	check passivity flag: if set to yes, a passivity check is performed and a warning is output if the device is not passive; if set to no, a passivity check is not performed.	None	yes

Notes/Equations

1. This model is based on S-parameters ($S_{12} = S_{21}, S_{13} = S_{31}$).
2. Up to three frequency break points can be used to define four bands, with different losses and VSWR for each frequency band.
Enter loss as a positive attenuation. In other words, a 0.5 dB loss is entered as Loss = 0.5, not Loss = -0.5.
3. Isolation is assumed to be constant across all frequency bands.
When using this device in a transient simulation, the switch setting must be constant.

SwitchV (Voltage Controlled Switch)

Symbol

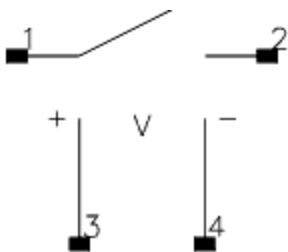

Available in ADS

Parameters

Name	Description	Units	Default
Model	Model instance name	None	SWITCHVM1
R1	Resistance at voltage 1	Ohm	1.0
V1	Voltage 1	V	0.0
R2	Resistance at voltage 2	MOhm	1.0
V2	Voltage 2	V	1.0

Range of Usage

$R1, R2 > 0$

$V1 \neq V2$

Notes/Equations

1. This component implements a voltage controlled switch. The switch resistance between nodes 1 and 2 varies as a function of the applied control voltage (V_{CON} is the voltage between nodes 3 and 4):

$$R_{SW} = \begin{cases} R1 & \text{if } V_{CON} \leq V1 \\ f(V_{CON}) & \text{if } V1 \leq V_{CON} \leq V2 \\ R2 & \text{if } V_{CON} \geq V2 \end{cases}$$

where

$$f(V_{CON}) = \begin{cases} x = \frac{V_{CON} - V1}{V2 - V1} \\ \text{if } x < 1/2 \\ y = 2x^2 \\ \text{else} \\ y = 1 - 2(x - 1)^2 \\ \ln(R_{SW}) = \ln(R1) + y \times \ln(R2/R1) \end{cases}$$

For these equations, it is assumed that $V1 < V2$. If $V2 < V1$, swap $R1$ and $V1$ with $R2$ and $V2$ in the equation above.

Advanced Design System 2008

VCON is defined so that $f(V1) = R1$ and $f(V2) = R2$ and provides a smooth transition between states. This is a plot of the switch resistance as a function of the control voltage for $V1=1$, $R1=10$, $V2=3$, $R2=10000$.

2. The Model name is optional. If the model name is not specified, then R1, V1, R2 and V2 must all be specified on the SwitchV instance; if the model name is specified, then R1, V1, R2 and V2 on the SwitchV instance are optional and override the values specified in the SwitchV_Model.
3. R1 and R2 are model parameters, not the resistance at nodes. Convergence problems may occur if the difference between R1 and R2 is too large.
4. V1 and V2 are model parameters, not node voltages. Convergence problems may occur if the difference between V1 and V2 is too small.
5. This component works in all analyses, including transient and circuit envelope simulation. If a SwitchV_Model item is not present, the SwitchV Model parameter should be blank.
6. [DC Operating Point Information](#) lists the DC operating point parameters that can be sent to the dataset.

Name	Description	Units
Is	Current	A
Power	DC power dissipated	W
Vs	Voltage	V

SwitchV_Model (Voltage Controlled Switch Model)

Symbol



Available in ADS

Parameters

Name	Description	Units	Default
------	-------------	-------	---------

R1	Resistance at voltage 1	Ohm	1.0
V1	Voltage 1	V	0.0
R2	Resistance at voltage 2	MOhm	1.0
V2	Voltage 2	V	1.0
AllParams	Data Access Component (DAC) Based Parameters	None	None

Range of Usage

R1, R2 > 0
V1 ≠ V2

Notes/Equations

1. This model supplies values for a SwitchV component.
2. The range between R1 and R2 should not be too large, or convergence problems may occur.
3. The difference between V1 and V2 should not be too small, or convergence problems may occur.
4. R1, V1, R2 and V2 can be optionally specified on the SwitchV instance that uses this model; those values override the model values.
5. This model works in transient and circuit envelope simulation.
6. Use AllParams with a DataAccessComponent to specify file-based parameters (refer to the DataAccessComponent). Note that model parameters that are explicitly specified take precedence over those specified via AllParams.

VSum (Voltage Summer)

Symbol

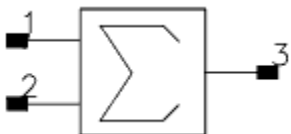

Available in ADS

Parameters

None

Notes/Equations

1. This component has infinite input impedance and zero output impedance. Output voltage is equal to voltage summed from the two input ports.

Tx/Rx Subsystems

RF_PA_CKT (RF Power Amplifier Circuit)

Symbol

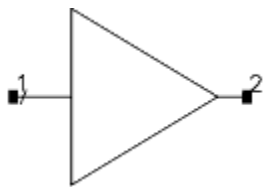

Available in ADS

Parameters

None

Notes/Equations

1. This is a 2-stage BJT amplifier with the center frequency of 2GHz, small signal gain of $\sim 30\text{dB}$, and maximum power output of $\sim 15\text{dBm}$. This circuit is provided for the convenience of easy inclusion of a circuit level amplifier in an ADS Ptolemy Envelope cosimulation.

RF_RX_SML (RF Receiver)

Symbol



Available in ADS

Parameters

Name	Description	Units	Default
RX_AntTemp	Receiving antenna noise temperature	None	150
RX_Gain	Receiver gain	dB	50
RX_NF	Receiver noise figure	dB	5
RF_Freq	RF frequency	MHz	900
RF_BW	RF bandwidth	MHz	25
IF_Freq1	First IF frequency	MHz	100
IF_Freq2	Second IF frequency	kHz	400
IF_BW	IF bandwidth	kHz	30
IP3in	Receiver input IP3	dBm	-25
RIn	Input resistance	Ohm	50

ROut	Output resistance	Ohm	50
------	-------------------	-----	----

Notes/Equations

1. This is a super-heterodyne RF receiver subsystem. Input is an RF signal; output is an IF signal. Three CW spurs are combined with the input RF signal to simulate the receiver interference performance. This subnetwork is provided for easy inclusion of an RF receiver in an ADS Ptolemy Envelope co-simulation.

RF_TX_SML (RF Transmitter)

Symbol



Available in ADS

Parameters

Name	Description	Units	Default
IF_Freq	IF frequency	kHz	400
RF_Freq	RF frequency	MHz	900
RF_BW	RF bandwidth	kHz	30
TX_Gain	Transmitter gain	dB	80
PSat	Saturated power at output	dBm	35
RIn	Input resistance	Ohm	50
ROut	Output resistance	Ohm	50

1. This is an RF transmitter subsystem. Input is an IF signal; output is an RF signal.
This subnetwork is provided for easy inclusion of an RF transmitter in an ADS Ptolemy Envelope co-simulation.

System Data Models

The System - Data Models palette contains two types of components: those which enable the simulation-based extraction of behavioral profiles from circuit models and those which perform behavioral modeling using these profiles. There is an inherent pairing of these two types of components because parameters used to define behavioral profiles in data-based representation are specific to modeling theories and therefore data model requirements. Data-based behavioral modeling is an important tool for the bottom-up verification process; thus, each extractor-data model pair of this palette is also known as a verification model extraction (VME) pair. The most common usage of a VME pair during RFIC and MMIC design flows is as follows:

- Creation of a circuit level design with circuit level components and/or parametric behavioral components during the top-down design phase. Parameter-based behavioral models are located in the Filters , System - Amps & Mixers , and System - Mod/Demod palettes. These models are characterized by a few independent parameters such as frequency, power and load.
- Creation of a Harmonic Balance-based dataset or data file profiles of these circuit level models using the VME extractor components from the System - Data Models palette. Use the VME data model counterparts to recreate the behavior of the circuit level models. Compare circuit- and data-based behavioral models; calibrate the data-based behavioral models prior to hardware prototyping the circuit.
- Using measurement instruments to extract behavioral datasets or data files from hardware prototypes from the foundry. Using the calibrated VME data model to generate a hardware behavioral profile. Compare the hardware behavioral profile with the simulation-based behavioral profile to estimate the success of prototyping.

The parameter-based behavioral models typically provide superior speed whereas data-based behavioral models typically provide superior accuracy. The differences between parameter - and data-based behavioral models justify the palette emphasis on ADS flow (separate palettes for parametric and data-based models) rather than functionality (separate palettes for amplifiers, mixers, modulators each containing both parametric and data-based models).

The BehavioralModels example suite was developed to promote the usability of the System-Data Models components. This family of example projects demonstrates the use and characteristics of most VME models. To access the example project from the ADS Main window click on the following sequence of menu options: File > Example Project > BehavioralModels. Notes for each example project are available in the accompanying notes in ADS Documentation > Examples > Behavioral Models manual.

In addition to the data-based behavioral model components, the System-Data Models palette includes Balun3Port and Balun4Port; these components are also accessible from the System-Passive palette.

Classification of ADS System Data Models

ADS provides data-based modeling for system-level VME components of the following categories:

- Amplifiers: AmplifierH1H2, AmplifierP2D, AmplifierS2D, AmpLoadPull, VCA_Data
- Mixers: MixerHBdata, MixIMT_Data
- Modulators / Demodulators: IQ_Mod, IQ_Demod

Most data models accept customized dataset (*.ds) or data file (*.p2d, *.s2d, *.imt) inputs. These inputs are typically provided by data model extractors. Identified by the suffix Setup or setup, these extractors are prefabricated subcircuits that run a predetermined simulation with user-settable sweep values on the circuit level model of interest and report the input and output stimuli in the dataset or data file form. The user is encouraged to push into the extraction subcircuits and be familiar with the measurement metrics that are being reported to the dataset or data file.

Most system data models have their own data extractors; however, there are exceptions for the older models MixerIMT and MixerIMT2 for which data files must be manually generated or retrieved from a measurement instrument.

[Data-Based Behavioral Modeling Components and Example Projects in ADS.](#) summarizes the availability and scope of each VME model currently available in ADS. This chapter describes component parameters and usage in further detail. For a discussion of the use of the ADS data model components from an application point of view please refer to the series of Application Notes being released under the title Behavioral Modeling in ADS .

Data-Based Behavioral Modeling Components and Example Projects in ADS.

Extractor Model	Data Model	Data Type	Comments on Scope of Modeling
AmpH1H2_Setup	AmpH1H2	.ds	Models nonlinearity at odd and even harmonics using circuit-based data at fundamental and second harmonics. Refer to Examples > BehavioralModels > AmpH1H2_prj
AmplifierP2D_Setup	AmplifierP2D	.p2d	Models nonlinearity and noise at fundamental frequency using circuit-based data at fundamental frequency. For circuit envelope simulations, modeling

			nonlinear distortion at fundamental frequency due to interference from spectral components within the envelope band. Refer to Examples > BehavioralModels > AmplifierP2D_prj
AmplifierS2D_Setup	AmplifierS2D	.s2d	Models nonlinearity and noise at fundamental and odd-order harmonic frequencies using circuit-based data at fundamental frequency. Assumes odd-order polynomial fitting for harmonic calculations. Refer to Examples > BehavioralModels > AmplifierS2D_prj
LoadPullSetup	AmpLoadPull	.ds	Models nonlinearity at fundamental frequency for various input and output impedance conditions using circuit-based data at single frequency for a range of source and load conditions. Refer to Examples > BehavioralModels > AmpLoadPull_prj
VCA_Setup	VCA_Data	.ds	Models nonlinearity at fundamental frequency for various settings of control voltage using circuit-based data at single frequency for a range of bias conditions. Refer to Examples > BehavioralModels > VCA_prj
MixIMTA_Setup MixIMTB_Setup	MixIMT_Data	.imt	Models nonlinearity at all mixing products for single (O-type and A-type) or multi (B-type) IMT files. Refer to Examples > BehavioralModels > MixIMT_pr j

MixerHBsetup	MixerHBdata	.ds	Models nonlinearity at fundamental, mixing product frequencies at the mixer output (IF) due to 1tone input signals (RF and LO) based on 1-tone harmonic balance characterization of circuit level mixer. Refer to Examples > BehavioralModels > MixerHBdata_prj
(Manual extraction)	MixerIMT ††	.imt †	Models nonlinearity at fundamentals and mixing product frequencies at the mixer output (IF) based on 1-tone input signals and a table of mixing coefficients.
(Manual extraction)	MixerIMT2	.imt †	Models nonlinearity at fundamentals and mixing product frequencies at the mixer output (IF) based on 1-tone input signals and a table of mixing coefficients.
IQ_Mod_Setup	IQ_Mod_Data	.ds	Models large-signal in-phase and quadrature components during modulation Refer to Examples > BehavioralModels > IQ_Mod_prj
IQ_Demod_Setup	IQ_Demod_Data	.ds	Models large-signal in-phase and quadrature components during demodulation Refer to Examples > BehavioralModels > IQ_Demod_prj
† This data model accepts only O-type IMT data. †† This is an obsolete component.			

AmpH1H2 (Amplifier/Fundamental and 2nd Harmonic vs. Input Power)

Symbol

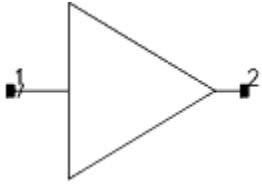

Available in ADS

Parameters

Name	Description	Units	Default
Dataset	Name of dataset containing data for this amplifier model	None	dataset.ds
G1expr †	Gain expression for fundamental frequency	None	Vout[1]
G2expr †	Gain expression for second harmonic frequency	None	Vout[2]
SP11 ††	Forward reflection coefficient	None	polar(0,0)
SP22 ††	Reverse reflection coefficient	None	polar(0,180)
SP12 ††	Reverse transmission coefficient	None	0
NF	Noise figure	dB	None
NFmin	Minimum noise figure at Sopt	dB	None
Sopt ††	Optimum Source Reflection for Minimum Noise Figure, use $x + j \times y$, polar(x,y), dbpolar(x,y) for complex value	None	None
Rn	Equivalent noise resistance; must be a non-negative real number		

Z1	Reference impedance for Port1		
Z2	Reference impedance for Port2		
† The gain parameters must be updated to appropriate gain expressions based on the MeasEqn expressions of AmpH1H2_Setup component which was used to create the dataset. Refer to example project AmpH1H2_prj. †† These parameters can be reported in any of the following complex number formats: $x + j \times y$, $\text{polar}(x,y)$, $\text{dbpolar}(x,y)$, $\text{vswrpolar}(x,y)$			

Notes/Equations

1. AmpH1H2 is a data-based system model of a circuit-level amplifier. The circuit-level amplifier is characterized by a dataset generated by the extractor component AmpH1H2_Setup. Various examples of the use of AmpH1H2 are provided in the example project AmpH1H2_prj.
2. This amplifier model does not require the explicit specification of nominal frequency at which non-linear modeling is to be performed. Although technically it can be used at any frequency during simulation, the dataset file contains the nonlinear profile at the single frequency point defined on the AmpH1H2_Setup component during extraction. Hence, effectively the AmpH1H2 model is confined to reproducing behavior accurately at that frequency only. Since the AmpH1H2 model does not have a built-in warning mechanism to detect discrepancies between simulation and extraction frequencies, the user of this model needs explicit apriori knowledge of the extraction frequency during behavioral simulation.
3. AmpH1H2 models both odd- and even-order harmonics at the amplifier output. However, its reliance on the fundamental and second-order harmonic expressions G1expr and G2expr. respectively, guarantee high accuracy only for these two spectral components. For details of the modeling accuracy of various harmonics in a 1-tone swept power Harmonic Balance simulation, refer to the data display plot behavioral_level_amp_SOITOI.dds in the example project AmpH1H2_prj.
4. The dataset contains information about the forward transmission characteristic S21. The other S-parameters S11, S12 and S22, can be set explicitly on the data model instance. Likewise, noise parameters NF, NFmin, Sopt and Rn, can be set explicitly using relevant parameters on the model instance.
5. It is important to note that although port impedances Z1 and Z2 can be set to arbitrary values during behavioral simulation, the dataset is typically extracted at port impedance values of 50 Ohms. Ideally, the settings for Z1 and Z2 inside the subcircuit of the extractor model AmpH1H2_Setup should be set up as complex conjugates of the input and output impedances, respectively, of the circuit amplifier. The resulting dataset would then contain the behavior under matched source and load conditions. In order to translate the dataset into the behavior of AmpH1H2, the AmpH1H2 Z1 and Z2 parameters must then be set to the complex conjugates of AmpH1H2_Setup component's Z1 and Z2 values, i.e. to the original values of the circuit amplifiers port impedances.

AmpH1H2_Setup (Amplifier/Fundamental and 2nd Harmonic vs. Input Power Setup)

Symbol

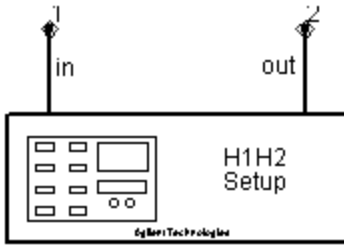

Available in ADS

Parameters

Name	Description	Units	Default
Freq	Fundamental frequency; must be a positive real number	GHz	1.0
Order	Order for Harmonic Balance analysis; must be an integer greater than 0	None	10
Pin_Start	Start value of input power sweep for harmonic balance analysis; must be a positive real number	dBm	-50
Pin_Stop	Stop value for input power sweep for harmonic balance analysis; must be a positive real number	dBm	-20
Pin_Step	Interval for input power sweep during harmonic balance analysis; must be a positive real number	dB	10

Notes/Equations

1. AmpH1H2_Setup performs a swept input power Harmonic Balance simulation of a circuit-level amplifier and generates a dataset for subsequent use by the data-based system model AmpH1H2. The AmpH1H2_Setup extractor model is demonstrated in the example project AmpH1H2_prj.

2. AmpH1H2_Setup can be pushed into for a view of the implementation. If necessary, the component can be copied and modified to suit individual needs.
3. This component is capable of extracting circuit behavior at only one nominal frequency Freq. In order to characterize an amplifier over a range of frequencies, separate extractions must be performed and separate datasets generated at each frequency of interest.
4. In order for AmpH1H2 to produce an accurate model of the circuit-level amplifier characterized via AmpH1H2_Setup, the Order parameter for AmpH1H2_Setup must be large enough to prevent aliasing of higher-order frequency components. The recommended value is 5 for mildly non-linear circuits and 11-15 for highly non-linear circuits.
5. The linear input power sweep is defined by the parameters Pin_Start, Pin_Stop and Pin_Step are used directly by the underlying Harmonic Balance controller.
6. The extracted ADS dataset is assigned the name of the extraction design by default.

AmplifierP2D (P2D File Amplifier, FDD-Based, for Single Carrier Signal)

Symbol

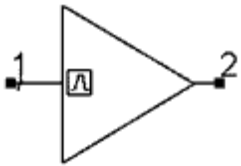

Available in ADS

Parameters

Name	Description	Units	Default
Freq	Fundamental frequency	GHz	1.0
P2DFile	Filename for P2D data	None	p2dfile.p2d
FilteringOption †	CE simulation option of pre / post filtering envelope frequencies relative to nonlinearity; enumerated options are: NoFilter, PreFilter, PostFilter	None	NoFilter
CEFreqSpacing †	Sampling frequency used for envelope simulation	MHz	1.0
iVarN ††	Name of Nth multi-dimensional variables $N=(1,\dots,N)$. Use if present in P2D file	None	None

Advanced Design System 2008

iValN ††	Value of Nth multi-dimensional variables $N=(1,\dots,N)$. Use real or integer values only	None	None
ImpNoncausalLength	Non-causal function impulse response order	Integer	None
ImpMode	Convolution mode	Integer	None
ImpMaxFreq	Maximum frequency to which device is evaluated		
ImpMaxOrder	Maximum allowed impulse response order	Integer	None
ImpWindow	Smoothing window	Integer	None
ImpRelTol	Relative impulse response truncation factor	None	None
ImpAbsTol	Absolute impulse response truncation factor	None	None

† The FilteringOption and CEFreqSpacing parameters are provided (beginning with 2003C) to enhance circuit envelope simulation capabilities; refer to note 8 and note 10 for details. The default values suppress effects of FilteringOption and CEFreqSpacing parameters to ensure backwards compatibility. CEFreqSpacing is the equivalent of ImpDeltaFreq in

† † AmplifierS2D with the restriction that it must always have an assigned value in AmplifierP2D. If multi-dimensional VAR statements are present in the P2DFile, then these variables are required to be listed in iVarN as indicated in note 12 and corresponding values assigned to them using the iValN parameter.

Notes/Equations

1. AmplifierP2D is a data-based system model of a circuit-level amplifier. The circuit-level amplifier is characterized by a P2D file generated either by the extractor component AmplifierP2D_Setup in a simulation environment or by a measurement instrument such as a network analyzer. Various examples of the use of the AmplifierP2D data model are provided in the example project AmpP2D_prj.
2. A P2D file, named *.p2d, contains small- and large-signal 2-port S-parameter data with optional noise parameters and intermodulation table data. The AmplifierP2D model only uses data related to amplifier modeling; it ignores frequency translation and intermodulation table data that may be contained in a generic P2D file. The referenced P2D file should reside in the data subdirectory of the current project. For details on P2D file format, refer to the "P2D Format" section in the Circuit Simulation manual.
3. The AmplifierP2D model blocks DC. For CE simulations, baseband signals are blocked.
4. For small-signal simulations such as AC and S-parameter analyses, AmplifierP2D only uses the small-signal S-parameters of the P2D file. For S-parameter analysis, the nominal frequency must be set as Freq=freq, where freq is the ambient simulation frequency. If the Freq parameter value falls outside the range of frequencies in the small-signal section of the P2D file, an error message is reported in the simulator log window and the simulation is terminated. Linear interpolation of S-parameters is performed within the small-signal range to emulate behavior at a frequency not explicitly registered in the data file. Linear extrapolation is enabled but not

recommended outside the small-signal frequency range because modeling accuracy cannot be guaranteed outside the data points of the P2D file.

5. For large-signal frequency analysis such as those based on Harmonic Balance, the power-dependent S-parameters from the ACDATA block are used in conjunction with small-signal parameters. For these simulations, Freq must be set to the fundamental frequency explicitly or through the pre-defined variable `_freq1`. Setting `Freq=freq` causes errors. For an N-tone Harmonic Balance simulation any of N frequencies specified on the controller may be chosen as nominal frequency for the AmplifierP2D component by setting `Freq=_freqX`, where X is in the integer range [1, N].
6. If the Freq parameter value falls outside the range of frequencies in the large-signal section of the P2D file, a warning message is reported in the simulator log window although the simulation is allowed to proceed. Linear interpolation along the frequency axis is permitted within the small- and large-signal range but extrapolation is not advised on either side of the large-signal limits because of insufficient data. It is important to scan the simulator log window at the end of any large-signal simulation involving the AmplifierP2D component to ensure that frequency limits were not exceeded.
7. If the power incident at the input of the amplifier model during large-signal frequency domain analyses, such as Harmonic Balance, LSSP or Circuit Envelope simulations, exceeds the maximum value of P1 in the P2D file a warning message is sent the simulator log window concerning unsupported modeling at high drive levels.
8. The FilteringOption parameter allows the user to regulate modeling of distortion effects at the fundamental frequency due to other frequencies within the envelope bandwidth during a circuit envelope simulation. Some harmonics and intermods produced by the non-fundamental tones within the CE-band contribute to the distortion of the fundamental tone at the output of the amplifier for high drive levels at the input. In the design of complex circuit level amplifiers this distortion is either regulated at the amplifier input or output using a narrowband filter. In order to imitate this feature during behavioral simulation AmplifierP2D enables the user to set the FilteringOption parameter to PreFilter or PostFilter so that appropriate filtering effects can be modeled without changing the P2D data file. It is useful to perform such CE-band distortion evaluation for certain applications (communications systems, for example). The NoFilter default setting suppresses estimation of envelope bandwidth distortion at the nominal frequency Freq; this setting is sufficient for all non-CE simulations.
9. The PreFilter or PostFilter option is for use during circuit envelope simulations only. Prefiltering of non-fundamental frequencies reduces the potential of distortion close to power saturation of the fundamental frequency at the output; postfiltering allows maximal non-linear distortion to occur at amplifier output. Maximally flat filtering is assumed across the entire envelope bandwidth. This distortion modeling feature is highlighted in the example design BEH_P2D_CE_filter.dsn.
10. The CEFreqSpacing parameter is used to select the granularity of envelope band frequencies that are allowed to impact the distortion of the fundamental frequency at amplifier output. There is an inherent performance trade-off in using this parameter: the smaller its value the more accurate the simulation but the longer the duration of the CE simulation. If filtering is enabled and CEFreqSpacing exceeds half the value of Freq a warning message is reported to the simulation log window and simulation proceeds without the use of filtering due to violation of the Nyquist sampling requirement for CEFreqSpacing. The recommended value for CEFreqSpacing is 10^{-3} (value assigned to Freq). This feature is highlighted in the example design BEH_P2D_CE_sample.dsn.
11. AmplifierP2D is implemented using the FDD model. Unlike the SML models Amplifier and Amplifier2 or the VME model AmplifierS2D, AmplifierP2D does not produce harmonics or intermods in a Harmonic Balance simulation. In a Harmonic Balance analysis, the only frequency component that can pass through AmplifierP2D is that specified by Freq. Signals at all other frequencies will see a ground at the input of AmplifierP2D. However, in a Circuit Envelope simulation, the envelope signal around the carrier frequency Freq will pass through AmplifierP2D and cause distortion at the fundamental Freq, whereas all signals outside the envelope band are ignored. To simulate multi-tone behavior involving harmonic modeling, consider using the AmpH1H2 or AmplifierS2D models.
12. The response of AmplifierP2D can be user-selected from a body of multi-dimensional P2D data by specifying the names and ambient values of such variables in the iVarN and iValN entries prior to behavioral simulation. Details of multi-dimensional P2D file generation are discussed in the notes for AmplifierP2D_Setup component and the

format of these files is described in Chapter 4 of the Circuit Simulation manual. If a given multi-dimensional P2D file contains "V" VAR variables then the names of all these variables need to be assigned using the iVar1 through iVarV parameters of the AmplifierP2D instance. Although the ordering of these names can be arbitrary relative to those in the P2D file, the existence and ordering of values in the iVal1 through iValV parameters should always correspond to that of iVar1 through iVarV. If a multi-dimensional VAR contained in the P2D data file is not specified on the iVarN of an AmplifierP2D instance reading that file, the simulation will be terminated on due to insufficient data for multi-dimensional data indexing. Currently, only real and integer values of multidimensional iVarN are supported.

AmplifierP2D_Setup (Extractor Component for AmplifierP2D)

Symbol

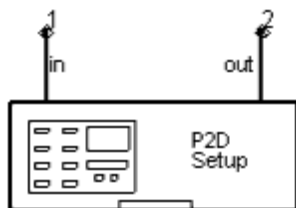

Available in ADS

Parameters

Name	Description	Unit	Default
Filename	Name of P2D file to be generated by extractor	None	p2dfile.p2d
Order	Order for Harmonic Balance simulation inside extractor; must be an integer greater than 0	None	10
Freq_Start	Start value for sweep of large-signal frequencies; must be a positive real	GHz	1.0

Advanced Design System 2008

	number		
Freq_Stop	Stop value for sweep of large-signal frequencies; must be a positive real number	GHz	2.0
Freq_Step †	Interval for linear sweep of large-signal frequencies; must be a positive real number	GHz	0.1
Pin_Start	Start value for sweep of large-signal input power; must be a real number	dBm	-10.0
Pin_Stop	Stop value for sweep of large-signal input power; must be a real number	dBm	15.0
Pin_Step †	Interval for linear sweep of large-signal input power; must be a positive real number	dB	5.0
SSFreq_Start ††	Start value for sweep of small-signal frequencies; must be a positive real number if specified		
SSFreq_Stop ††	Stop value for sweep of small-signal frequencies; must be a positive real number if specified		
SSFreq_Step †, ††	Interval for linear sweep of small-signal frequencies; must be a positive real number if specified		
<p>† Only linear sweeps using intervals of Freq_Step, Pin_Step, SSFreq_Step are permitted frequency and power extractions using the AmplifierP2D_extractor. †† Small-signal frequency settings, if left unspecified, will default to large-signal frequency specifications. The default behavior of this component is to enforce SSFreq_Start <= Freq_Start, SSFreq_Stop >= Freq_Stop and SSFreq_Step <= Freq_Step. Violations of this will result in internal correction with warning messages being reported to the simulator log window. Refer to note 4 for modifying this default behavior.</p>			

Notes/Equations

1. AmplifierP2D_Setup is a data file extractor component used to create multi-dimensional behavioral profiles of a

circuit level amplifier in the P2D format. The use of this component is highlighted in the design CKT_P2D_extraction.dsn of the example project AmpP2D_prj.

2. AmplifierP2D_Setup can be pushed into for a view of the implementation. If necessary, the component can be copied and modified to suit individual needs.
3. AmplifierP2D_Setup performs a linear swept input frequency over linear swept input power P2D (Harmonic Balance) simulation of a circuit-level amplifier and generates a P2D file for subsequent use by the data-based system model AmplifierP2D. The Freq_ and Pin_ parameters regulate the large-signal frequency and input power sweeps, respectively.
4. The small-signal frequency sweep can be specified independently of the large- signal frequency sweep using SSFreq_ parameters. When unspecified, these values internally default to large-signal values. When specified in violation of the rule that $SSFreq_Start \leq Freq_Start$, $SSFreq_Stop \geq Freq_Stop$ and $SSFreq_Step \leq Freq_Step$, this rule is imposed internally during simulation and warning messages appear in the simulator log window. This ensures the small-signal frequency sweep spans the large-signal frequency sweep and is at least as finely grained. This is the coarsest granularity for reliable modeling using the AmplifierP2D data model.
5. In order for AmplifierP2D to produce an accurate model of the circuit-level amplifier characterized via AmplifierP2D_Setup, the Order parameter for AmplifierP2D_Setup must be large enough to prevent aliasing of higher-order frequency components. Because the AmplifierP2D data model reads and operates primarily on its assigned fundamental frequency, it is important to provide an accurate estimate of the fundamental response at the circuit level amplifier output. Therefore, it is important to use a large order of harmonics in AmplifierP2D_Setup to reconstruct the fundamental accurately during data modeling. The recommended value is 5 for mildly non-linear circuits and 11-15 for highly non-linear circuits.
6. For information regarding the P2D data format, refer to the "P2D Format" section in the Circuit Simulation manual. Multi-dimensional P2D files may be generated by simply placing a chain of ParamSweep controllers above the AmplifierP2D_Setup instance and assigning the lowest sweep to have `SimInstance[1]="Xi1.HB"` where "Xi" is the instance name of the P2D extractor and HB1 is the default name of the P2D controller within its subcircuit.

AmplifierS2D (S2D File Amplifier, Polynomial Model for Nonlinearity)

Symbols:

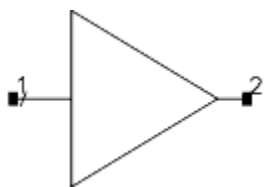

Available in ADS

Advanced Design System 2008

Parameters

Name	Description	Units	Default
S2DFile †	Filename for S2D data; enumerated as: S2D filename, File Based	None	s2dfile.s2d
SSFreq	Small signal frequency for interpolating S-parameters; enumerated as: auto, freq, _freq1, _freq2, _freq3	None	auto ††
InterpMode	Interpolation mode; enumerated as: Linear, Cubic Spline, Cubic, Value Lookup, , Value	None	Linear
InterpDom	Interpolation geometry; enumerated as: Data Based, Rectangular, Polar, DB	None	Data Based
GCFreq †††	Reference frequency for gain compression; must be a positive real number if specified		
VarName ‡	Name of 1st multi-dimensional variable; use if present in S2D file	None	None
VarValue ‡	Value of 1st multi-dimensional variable; use real or integer values only	Integer	None
iVarN ‡	Name of Nth multi-dimensional variables $N=\{2,\dots,N\}$; use if present in S2D file	None	None
iValN ‡	Value of Nth multi-dimensional variables $N=\{2,\dots,N\}$; use real or integer values only	Integer	None
ImpNoncausalLength ††	Non-causal function impulse response order	Integer	None
ImpMode ††	Convolution mode	Integer	None
ImpMaxFreq ††	Maximum frequency to which device is evaluated		

ImpDeltaFreq ##	Sample spacing in frequency	Integer	
ImpMaxOrder ##	Maximum allowed impulse response order	Integer	None
ImpWindow ##	Smoothing window	None	None
ImpRelTol ##	Relative impulse response truncation factor	None	None
ImpAbsTol †	Absolute impulse response truncation factor	Integer	None

† The "S2D Filename" option allows the entry of an S2D file directly. The "File Based" option enables the use of a DataAccessComponent (DAC) for reading in non-S2D file based data.

Implies "_freq1" for non-DC part of HB/CE/LSSP simulations. It implies "freq" for all other simulations. For multitone simulations setting SSFreq=_freq1 explicitly gives better results. In general "_freqX" allows the specification of any one of the X tones in an X-tone Harmonic Balance simulation, e.g. selecting SSFreq=_freq2 sets the small-signal frequency of interest to be the second tone of a 2+ tone HB simulation.

+++ If manually specified, this frequency must explicitly exist in the S2D file. No interpolation or extrapolation is done along frequency axis for estimating compression characteristics.

‡ If multi-dimensional VAR statements are present in the S2DFile, then these variables are required to be listed in iVarN as indicated in note 8] and corresponding values assigned to them using the iValN parameter. Note that VarName and VarValue serve as iVar1 and iVal1 respectively because of historical reasons.

These parameters are also used as specifications for the Amplifier and Amplifier2 components.

Range of Usage

S2D gain compression valid parameter ranges:

GCOMP3: $IP3 > 1DBC + 10.6$

GCOMP4: $IP3 > PS + 8.6$

GCOMP5: $PS > 1DBC + 3$

GCOMP6: $PS > 1DBC + 3, IP3 > 1DBC + 10.6$

Notes/Equations

1. AmplifierS2D is a data-based behavioral model that can represent fundamental tone(s), odd-order harmonics and odd-order intermodulation products of a circuit level amplifier. This model accepts S2D data profiles which can be generated using the AmplifierS2D_Setup component as shown in the design CKT_S2D_extraction.dsn in

the example project AmpS2D_prj . Various examples of the use of AmplifierS2D are also provided in this project.

2. An S2D file, named * .s2d , contains small-signal 2-port S-parameter data with optional noise parameters. In addition, it contains small-signal S-parameter data blocks, noise data blocks, and one of seven possible gain compression blocks {GCOMP1, ... , GCOMP7}. For information regarding the small- or large-signal S-parameter *.s2d data format, refer to the "S2D Format" section in the Circuit Simulation manual. The AmplifierS2D model only uses data related to amplifier modeling; it ignores frequency translation data that may be contained in a generic S2D file. The referenced S2D file should reside in the data subdirectory of the current project. The AmplifierS2D_Setup extractor model can be used to automatically generate S2D files.
3. The AmplifierS2D model blocks DC. For CE simulations, baseband signals are blocked.
4. For small signal simulations such as AC and S-parameter analyses, AmplifierS2D uses only the small signal ACDATA section of the S2D file. For small signal simulations SSFreq is effectively set to freq internally regardless of user defined enumeration. The GCFreq parameter has no effect on small signal simulations and may be left unassigned.

For large signal simulations, SSFreq may be defined using any of the five possible enumerations with the following effects:

- SSFreq = auto implies first HB/Envelope tone. This implies that the reference value for small signal S-parameters is fixed at the 2- port values for _freq1 regardless of the operational compression frequency GCFreq . This is the desirable setting for single tone HB/Envelope simulations.
- SSFreq = freq implies that the amplifier will be sensitive to small signal values based on individual input tones. This setting is desirable for multi-tone HB / Envelope analyses.
- SSFreq = _freqN, N={1,2,3}, provides a special provision allowing you to select the small signal value at the first, second, or third HB/Envelope tone on file as the reference for all incoming tones in a generic HB simulation.

 Note Leaving the default value of SSFreq=auto enables the AmplifierS2D instance to function adequately and conveniently for small signal SP/AC as well as single tone HB/Envelope simulations. For multi-tone large signal simulations, SSFreq should be set to freq to allow small signal frequency sensitivity.

5. For large-signal frequency analysis such as those based on Harmonic Balance, the small-signal S-parameters are used in conjunction with gain compression information in the GCOMPx block. Only odd-order harmonics are modeled during such large-signal simulations because information about even-order harmonics cannot be derived from the GCOMPx specification.
6. If gain compression information is presented in the GCOMP7 format at multiple frequencies, the AmplifierS2D GCFreq parameter must be assigned to one of the explicitly defined large-signal frequencies of the * .s2d file. The data model does not interpolate across large-signal frequencies so any violation of this requirement will result in termination of the simulation. This model resolves conflicts between user-assigned GCFreq values and large-signal frequency points in GCOMP7-based S2D files as shown in [Using GCFreq to Resolve GCOMP7 Frequency Conflicts](#).

Using GCFreq to Resolve GCOMP7 Frequency Conflicts

Number of GCOMP7 blocks	Large signal frequencies (s2dfreq) specified in S2D file?	GCFreq specified on AmplifierS2D?	GCFreq = one s2dfreq?	Simulation Result. Compression data used at ...
0	N/A	any	N/A	N/A

1	no	no	N/A	simulation frequency
		yes	N/A	GCFreq
	yes	no	N/A	s2dfreq
		yes	no	N/A. Simulation terminated with error message.
		yes	GCFreq = s2dfreq	
> 1	no	no	N/A	simulation frequency
		yes	N/A	GCFreq. Use first available power sweep from GCOMP7
	yes	no	N/A	N/A. Simulation terminated with error message.
		yes	no	N/A. Simulation terminated with error message.
		yes	GCFreq = s2dfreq	

7. For good performance using AmplifierS2D, include multiple GCOMP7 blocks at closely-spaced frequencies.
8. AmplifierS2D can access multi-dimensional S2D files as shown in BEH_S2D_HB_1tone.dsn of the example project AmpS2D_prj. Previous versions of this component required a DataAccessComponent (DAC) for accessing multi-dimensional data. A DAC is no longer necessary to access S2D data from a single file. Please note that multiple S2D files cannot be fed to the same AmplifierS2D component in the course of a single simulation. When S2D data is available in multiple files, consolidate the S2D data into one file and use this master file as the input to AmplifierS2D. Relevant sections of this new file can now be conveniently accessed using the VarName, VarValue and iVar2, iVal2 through iVar10 and iVal10 parameters of the component. Automatic multi-dimensional S2D file generation is facilitated by using the AmplifierS2D_Setup component.
9. The S21 values expressed in the GCOMP7 block are not absolute values of S21 at the various input power PIN levels. They are differential values in dB domain between power-swept S-parameters at the frequency of the GCOMP7 block and the small-signal S-parameters at the same frequency in the ACDATA block of the *.s2d file. The formats in which ACDATA and GCOMP7 data are represented in the same file may differ and may be in any of the forms DB / MA / RI. When calculating GCOMP7 values manually, exercise care to convert absolute values of both large- and small-signal S-parameters to the dB domain before subtracting the small-signal S-parameters from the large-signal S-parameters to obtain the numeric values in the GCOMP7 section.
10. AmplifierS2D is implemented using the SML Amplifier model. However, the gain compression information available via an S2D file is limited to the forward transmission characteristic defined by S21. If an application requires the knowledge and use of all four 2-port S-parameter variations but not the use of harmonics, consider using the AmplifierP2D model. If even-order harmonics must be modeled but sweeps of frequency are not required, consider using the AmpH1H2 model instead.

AmplifierS2D_Setup (Extractor Component for AmplifierS2D)

Symbol

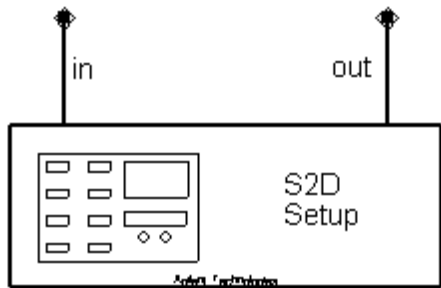

Available in ADS

Parameters

Name	Description	Units	Default
Filename	Name of P2D file to be generated by extractor	None	s2dfile.s2d
Order	Order for Harmonic Balance simulation inside extractor; must be an integer greater than 0	None	10
Freq_Start	Start value for sweep of large-signal frequencies; must be a positive real number	GHz	1.0
Freq_Stop	Stop value for sweep of large-signal frequencies; must be a positive real number	GHz	2.0

Freq_Step †	Interval for linear sweep of large-signal frequencies; must be a positive real number	GHz	0.1
Pin_Start	Start value for sweep of large-signal input power; must be a real number	dBm	-10.0
Pin_Stop	Stop value for sweep of large-signal input power; must be a real number	dBm	15.0
Pin_Step †	Interval for linear sweep of large-signal input power; must be a positive real number	dB	5.0
SSFreq_Start ††	Start value for sweep of small-signal frequencies; must be a positive real number if specified		
SSFreq_Stop ††	Stop value for sweep of small-signal frequencies; must be a positive real number if specified		
SSFreq_Step †, ††	Interval for linear sweep of small-signal frequencies; must be a positive real number if specified		

† Only linear sweeps using intervals of Freq_Step, Pin_Step, SSFreq_Step are permitted frequency and power extractions using the AmplifierP2D_extractor. †† Small-signal frequency settings, if left unspecified, will default to large-signal frequency specifications. The default behavior of this component is to enforce SSFreq_Start <= Freq_Start, SSFreq_Stop >= Freq_Stop and SSFreq_Step <= Freq_Step. Violations of this will result in internal correction with warning messages being reported to the simulator log window. Refer to note 4 for information about modifying this default behavior.

Notes/Equations

1. AmplifierS2D_Setup is a data file extractor component used to create multi-dimensional behavioral profiles of a circuit level amplifier in the S2D GCOMP7 format. The use of this component is highlighted in the design CKT_S2D_extraction.dsn of the example project AmpS2D_prj.
2. AmplifierS2D_Setup can be pushed into for a view of the implementation. If necessary, the component can be copied and modified to suit individual needs.
3. AmplifierS2D_Setup performs a linear swept input frequency over linear swept input power P2D (Harmonic Balance) simulation of a circuit-level amplifier and generates an S2D file for subsequent use by the data-based

system model AmplifierP2D. The Freq_ and Pin_ parameters regulate the large-signal frequency and input power sweeps, respectively. The power sweep is registered in the GCOMP7 format.

4. The small-signal frequency sweep can be specified independently of the large-signal frequency sweep using SSFreq_ parameters. When unspecified, these values internally default to large-signal values. When specified in violation of the rule that $SSFreq_Start \leq Freq_Start$, $SSFreq_Stop \geq Freq_Stop$ and $SSFreq_Step \leq Freq_Step$, this rule is imposed internally during simulation and warning messages appear in the simulator log window. This ensures the small-signal frequency sweep spans the large-signal frequency sweep and is at least as finely grained. This is the coarsest granularity for reliable modeling using the AmplifierS2D data model.
5. In order for AmplifierS2D to produce an accurate model of the circuit-level amplifier characterized via AmplifierS2D_Setup, the Order parameter for AmplifierS2D_Setup must be large enough to prevent aliasing of higher-order frequency components. Because the AmplifierS2D data model reads and operates primarily on its assigned fundamental frequency, and uses this frequency to create odd-order harmonics at the output, it is important to provide an accurate estimate of the fundamental response at the circuit level amplifier output. Therefore, it is important to use a large order of harmonics in AmplifierS2D_Setup to reconstruct the fundamental accurately during data modeling. The recommended value is 5 for mildly non-linear circuits and 11-15 for highly non-linear circuits.
6. For information regarding the S2D data format, refer to the "S2D Format" section in the Circuit Simulation manual. Multi-dimensional S2D files may be generated by simply placing a chain of ParamSweep controllers above the AmplifierS2D_Setup instance and assigning the lowest sweep to have `SimInstance[1]="Xi.HB1"` where " Xi " is the instance name of the S2D extractor and HB1 is the default name of the P2D controller within its subcircuit.

AmpLoadPull (SDD Load-Pull Amplifier)

Symbol

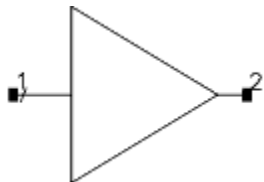

Available in ADS

Parameters

Name	Description	Units	Default
Dataset †	Name of dataset containing load-pull data for this amplifier model	None	dataset.ds
† File-based data is also supported via use of the DataAccessComponent			

Notes/Equations

1. For amplifier designers, the AmpLoadPull and LoadPullSetup components address the issue of output match in one or more frequency bands. This is often investigated via load-pull contours indicating the load impedances, which, when presented to the output of an amplifier with a given source impedance and power, cause a certain power to be delivered to the load. The LoadPullSetup component extracts a dataset, given ranges and steps for input power, output reflection coefficient magnitude and output reflection coefficient angle. AmpLoadPull uses this dataset and allows fast behavioral amplifier simulations for all input power and output reflection coefficient values in the specified ranges.
2. This amplifier model uses the load-pull ADS dataset generated by the LoadPullSetup component. This behavioral profile can be referenced using the Dataset parameter of the AmpLoadPull component.
3. AmpLoadPull is useful in modeling nonlinear amplifiers with or without input/output matching networks. This model can be used in all types of simulations.
4. When using this model in other simulations, ensure the input power and the load value are within the range of the original data.
5. The use of this device and its extractor component is highlighted in the example project AmpLoadPull_prj.
6. This model does not generate harmonics, and its performance is not affected by the source or load impedances presented to it at the harmonic frequencies.

Balun3Port (Balun, 3-port)

Symbol

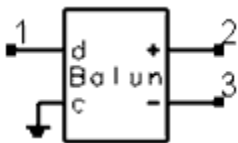

Available in ADS

Parameters

None

Notes/Equations

- Balun3Port realizes the ideal transformation between a balanced differential-mode signal and unbalanced, single-ended signals. It can be useful to connect a source to a differentially fed circuit, although it does ignore common-mode effects.
- Balun3Port realizes the voltage and current transformations given by:

$$v_d = v_+ - v_-$$

$$i_+ = i_- = -i_d$$
 where
 - v_d / i_d = the differential mode voltage/current at pin d
 - v_+ / i_+ = the single line voltage/current at pin +
 - v_- / i_- = the single line voltage/current at pin -
 See P.R. Gray and R.G. Meyer, "Analysis and Design of Analog Integrated Circuits", Third Edition, John Wiley & Sons, NY, 1993, equations 3.91 & 3.92.
 The minus signs in the current definitions are due to the standard definition of currents directed into the Balun3Port component.
- An equivalent functionality can be realized with a Balun4Port that has the common-mode pin grounded. However, the Balun3Port provides better convergence properties.
- Balun3Port is bi-directional. When fed at the differential-mode pin, it realizes the transformations:

$$v_+ = -v_- = (v_d)/2$$

$$i_+ = -i_- = -i_d$$
- Examples of using Balun3Port to convert between (unbalanced) ADS sources and balanced circuits can be found in the ADS examples directory; access these examples from the ADS Main window > File > Example Project .
 - RFIC > MixerDiffMode_prj demonstrates the use of Balun4Port to present differential-mode sources (as well as common mode biases) to the RF and LO inputs. It also shows the use of Balun3Port to single-ended (differential-mode) IF output, which is needed to properly calculate the noise figure.
 - BehavioralModels > DifferentialModels_prj demonstrates the use of Balun3Port and Balun4Port in conjunction with single-ended System-Data Models in order to create a data-based behavioral model of a differentially fed mixer.

Balun4Port (Balun, 4-port)

Symbol

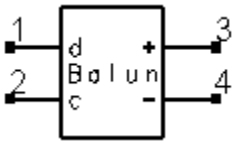

Available in ADS

Parameters

None

Notes/Equations

1. Balun4Port realizes the ideal transformation between balanced (differential- and common-mode) signals and unbalanced (single-ended) signals. It can be used to connect sources to a differentially fed circuit, particularly when modeling common-mode effects are important.
2. Balun4Port realizes voltage and current transformations given by:

$$v_d = v_+ - v_-$$

$$v_c = (v_+ + v_-)/2$$

$$i_d = -(i_+ - i_-)/2$$

$$i_c = -(i_+ + i_-)$$
 where
 - v_d / i_d = differential mode voltage/current at pin d
 - v_c / i_c = common mode voltage/current at pin c
 - v_+ / i_+ = single line voltage/current at pin +
 - v_- / i_- = single line voltage/current at pin -
 See P.R. Gray and R.G. Meyer, "Analysis and Design of Analog Integrated Circuits", Third Edition, John Wiley & Sons, NY, 1993, equations 3.91 and 3.92.
 The minus signs in the current definitions are due to the standard definition of currents directed into the Balun4Port component.
3. Balun4Port is bi-directional. It converts common/differential-mode signals into two single-ended signals, as well as converting two single-ended signals into common/differential mode signals.
4. If common-mode effects are not desired, Balun3Port provides an equivalent, but numerically more robust, result as grounding the common-mode pin of Balun4Port.
5. Examples of using Balun4Port to convert between (unbalanced) ADS sources and balanced circuits can be found in the ADS examples directory; access these examples from the ADS Main window > File > Example Project .
 - RFIC > MixerDiffMode_prj demonstrates the use of Balun4Port to present differential-mode sources (as well as common mode biases) to the RF and LO inputs. It also shows the use of Balun3Port to single-ended (differential-mode) IF output, which is needed to properly calculate the noise figure.
 - BehavioralModels > DifferentialModels_prj demonstrates the use of Balun3Port and Balun4Port in conjunction with single-ended System-Data Models in order to create a data-based behavioral model of a

differentially fed mixer.

IQ_Demod_Data (IQ Demodulator Behavioral Model)

Symbol

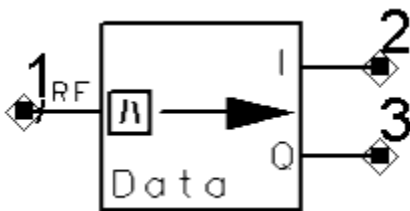

Available in ADS

Parameters

Name	Description	Units	Default
Dataset	Name of dataset generated by IQ_Demod_Setup	None	dataset.ds
Freq	Carrier Frequency	GHz	1.0

Notes/Equations

1. IQ_Demod_Data is a data-based system model of a circuit-level I/Q demodulator. The circuit-level demodulator is characterized by a dataset generated by the system component IQ_Demod_Setup. The use of this component is highlighted in the example project IQ_Demod_prj.
2. The demodulation behaviors are extracted for a single carrier frequency. Only the demodulation distortions are characterized, so it is possible to set the frequency parameter in IQ_Demod_Data to differ from the value set in IQ_Demod_Setup. The demodulation will occur at the frequency set in IQ_Demod_Data. The extracted distortions to the baseband signal as it passes through IQ_Demod_Data will be applied at this frequency. IQ_Demod_Data does not model any dispersion in these distortions across the baseband bandwidth.
3. IQ_Demod_Data is designed for Circuit Envelope system verification where various filters typically eliminate

unwanted frequency components. Therefore, IQ_Demod_Data makes no attempt to model harmonic components. The signals generated on the I and Q output ports are purely baseband signals. IQ_Demod_Data does not generate any frequency components at any carrier frequency.

4. In order for IQ_Demod_Data to produce an accurate model of the circuit-level demodulator characterized via IQ_Demod_Setup, the IQ_Demod_Setup Order parameter must be large enough to prevent aliasing of higher-order frequency components. For mildly non-linear circuits, an Order of about 5 should suffice, while an Order in the range of 10-15 is recommended for highly non-linear circuits. Providing this criterion is met, the Order parameter for the simulation controller can be very low when using IQ_Demod_Data in a Circuit Envelope simulation. Typically, an Order of around 3 should suffice for accurate demodulation modeling. Note, however, that accurate modeling of other components of the complete system may necessitate a larger value for this parameter.
5. For a circuit-level demodulator, the impedances presented by the input and output pins will generally be a complicated function of all state variables within the demodulator. For the IQ_Demod_Data, a certain simplification is necessary as no information about the environment in which the demodulator will later reside is known at the time of extraction. The input impedance at the RF input pin is extracted at the RF carrier frequency specified in IQ_Demod_Setup, and is a function of the input power. The impedances at the I and Q output pins are extracted at DC, and are modeled as constant impedances.
6. The extrapolation properties of IQ_Demod_Data above Pin_Stop are very poor. When using IQ_Demod_Data, ensure that the RF input signal does not exceed the Pin_Stop value set in IQ_Demod_Setup when the model was extracted. Extrapolation to signal levels below the Pin_Start value set in IQ_Demod_Setup will generally be good as long as the Pin_Start value lies within the linear operating range of the demodulator.
7. IQ_Demod_Data does not model noise.

IQ_Demod_Setup (IQ Demodulator Setup)

Symbol

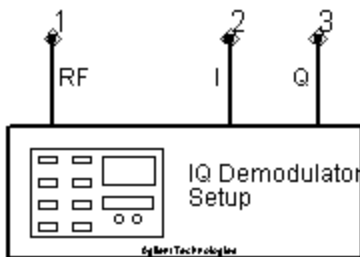

Available in ADS

Parameters

Name	Description	Units	Default
Freq	Modulation carrier frequency; must be a non-negative real number	GHz	1.0
Order	Order for Harmonic Balance analysis; must be a positive integer greater than 0	None	10
Pin_Start †	Start value of input power sweep for harmonic balance analysis; must be a real number	dBm	-40
Pin_Stop †	Stop value for input power sweep for harmonic balance analysis; must be a real number	dBm	10
Pin_Step †	Interval for input power sweep during harmonic balance analysis; must be a real number	dB	2
† All power values are referenced to a 50 Ohm system. Pin_Stop \geq the following values: $10 + 20 \times \log_{10}(v_{max})$ where v_{max} is the maximum peak voltage magnitude of the modulated signal. $P_{max,z} + 10 \times \log_{10}(z/50)$ where $P_{max,z}$, is the maximum modulated signal power in dBm for a z Ohm system.			

Notes/Equations

1. IQ_Demod_Setup performs a swept Harmonic Balance simulation of a circuit-level I/Q demodulator and generates a dataset for subsequent use by the data-based system model IQ_Demod_Data. The use of this component is highlighted in the example project IQ_Demod_prj.
2. In order for IQ_Demod_Data to produce an accurate model of the circuit-level demodulator characterized by IQ_Demod_Setup, the Order parameter for IQ_Demod_Setup must be large enough to prevent aliasing of higher-order frequency components. For mildly non-linear circuits, an Order of approximately 5 should suffice, while an Order in the range of 10-15 is recommended for highly non-linear circuits.
3. The demodulation behaviors are extracted for a single carrier frequency and over the range of modulated signal power specified by Pin_Start and Pin_Stop . These power values are specified in dBm with respect to a 50 Ohm system. For an accurate IQ_Demod_Data behavioral model, Pin_Stop must be set at least as large as the expected maximum modulated signal power level. Refer to the Parameters table footnotes for conversion if working in other than a 50-Ohm system.
4. Push into IQ_Demod_Setup in a Schematic window for a view of the swept Harmonic Balance simulation controllers. This component can be copied and modified to suit individual needs; typically, this would entail

changing the Harmonic Balance controller HB1 to achieve more efficient simulations. For more information, refer to the Harmonic Balance Simulation manual.

5. The extracted ADS dataset is assigned the name of the extraction design by default.

IQ_Mod_Data (IQ Modulator Behavioral Model)

Symbol

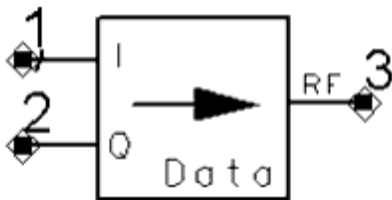

Available in ADS

Parameters

Name	Description	Units	Default
Dataset	Name of dataset generated by IQ_Mod_Setup	None	dataset.ds
Freq	Carrier Frequency	GHz	1.0

Notes/Equations

1. IQ_Mod_Data is a data-based system model of a circuit-level I/Q modulator. The circuit-level modulator is characterized by a dataset generated by the system component IQ_Mod_Setup. The use of this component is highlighted in the example project IQ_Mod_prj.
2. The modulation behaviors are extracted for a single carrier frequency. Only the modulation distortions are characterized, so it is possible to set the frequency parameter in IQ_Mod_Data to differ from the value set in IQ_Mod_Setup. The modulation will occur at the frequency set in IQ_Mod_Data. The extracted distortions to the baseband signal as it passes through IQ_Mod_Data will be applied at this frequency. IQ_Mod_Data does not

model any dispersion in these distortions across the baseband bandwidth.

3. IQ_Mod_Data is designed for Circuit Envelope system verification where various filters typically eliminate unwanted frequency components. Therefore, IQ_Demod_Data makes no attempt to model harmonic components. The signal generated on RF output port is only a baseband signal modulated onto the carrier frequency. IQ_Mod_Data does not generate any frequency components at DC or at any harmonic of the carrier frequency.
4. In order for IQ_Mod_Data to produce an accurate model of the circuit-level demodulator characterized via IQ_Mod_Setup, the Order parameter for IQ_Mod_Setup must be large enough to prevent aliasing of higher-order frequency components. For mildly non-linear circuits, an Order of approximately 5 should suffice, while an Order in the range of 10-15 is recommended for highly non-linear circuits. Providing this criterion is met, the Order parameter for the simulation controller can be very low when using IQ_Mod_Data in a Circuit Envelope simulation. Typically, an Order of approximately 3 should suffice for accurate demodulation modeling. Note, however, that accurate modeling of other components of the complete system may necessitate a larger value for this parameter.
5. For a circuit-level modulator, the impedances presented by the input and output pins will generally be a complicated function of all state variables within the modulator. For the IQ_Mod_Data, a certain simplification is necessary as no information about the environment in which the modulator will later reside is known at the time of extraction. Specifically, IQ_Mod_Data presents a constant inward-looking impedance at the input and output pins. The input impedances at the baseband input pins are extracted at DC, while the impedance at the RF output pin is extracted at the RF carrier frequency specified in IQ_Mod_Setup.
6. The extrapolation properties of IQ_Mod_Data above Pin_Stop are very poor. When using IQ_Mod_Data, please ensure that the input baseband signal does not exceed the Pin_Stop value set in IQ_Mod_Setup when the model was extracted. Note that the Pin_Stop value is in reference to the complex baseband signal, which is typically a factor of $\sqrt{2}$, or 3 dB, larger than the power of the signal at either individual input pin. Extrapolation to signal levels below the Pin_Start value set in IQ_Mod_Setup will generally be good as long as the Pin_Start value lies within the linear operating range of the modulator.
7. IQ_Mod_Data does not model noise.

IQ_Mod_Setup (IQ Modulator Setup)

Symbol

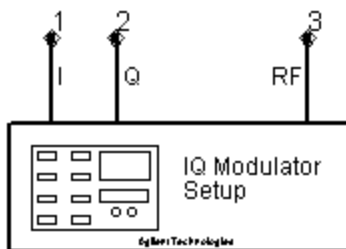

Available in ADS

Parameters

Name	Description	Units	Default
Freq	Modulation carrier frequency; must be a non-negative real number	GHz	1.0
Order	Order for Harmonic Balance analysis; must be a positive integer greater than 0	None	10
Pin_Start †	Start value of input power sweep for harmonic balance analysis; must be a real number	dBm	-40
Pin_Stop †	Stop value for input power sweep for harmonic balance analysis; must be a real number	dBm	10
Pin_Step †	Interval for input power sweep during harmonic balance analysis; must be a real number	dB	2

† All power values are referenced to a 50-Ohm system. $Pin_Stop \geq$ the following values: $10 + 20 \times \log_{10}(v_{max})$ where v_{max} is the maximum peak voltage magnitude of the modulated signal $\sqrt{(|V_i|^2 + |V_q|^2)}$. $P_{max,z} + 10 \times \log_{10}(z/50)$ where $P_{max,z}$ is the maximum modulated signal power in dBm for a z Ohm system.

Notes/Equations

1. IQ_Mod_Setup performs a swept Harmonic Balance simulation of a circuit-level I/Q modulator and generates a dataset for subsequent use by the data-based system model IQ_Mod_Data. The use of this component is highlighted in the example project IQ_Mod_prj .
2. In order for IQ_Mod_Data to produce an accurate model of the circuit-level demodulator characterized by IQ_Mod_Setup, the Order parameter for IQ_Mod_Setup must be large enough to prevent aliasing of higher-order frequency components. For mildly non-linear circuits, an Order of approximately 5 should suffice, while an Order in the range of 10-15 is recommended for highly non-linear circuits.
3. The modulation behaviors are extracted for a single carrier frequency and over the range of modulation signal power specified by Pin_Start and Pin_Stop . These power values are specified in dBm with respect to a 50-Ohm system. For an accurate IQ_Mod_Data behavioral model, Pin_Stop must be set at least as large as the expected

maximum modulated signal power level. Refer to the Parameters table footnotes for conversion if working in other than a 50-Ohm system.

4. Push into IQ_Mod_Setup in a Schematic window for a view of the swept Harmonic Balance simulation controllers. This component can be copied and modified to suit individual needs; typically, this would entail changing the Harmonic Balance controller HB1 to achieve more efficient simulations. For more information, refer to the Harmonic Balance Simulation manual.
5. The extracted ADS dataset is assigned the name of the extraction design by default.

LoadPullSetup (Load Pull Setup)

Symbol

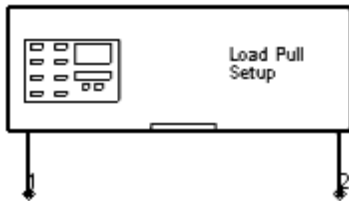

Available in ADS

Parameters

Name	Description	Units	Default
Freq	Frequency of extraction; must be a non-negative real number	GHz	1.0
Order	Order for Harmonic Balance simulation inside extractor; must be an integer greater than 0	None	10
Pin_Start	Start value for sweep of large-signal input power; must be a real number	dBm	-50

Pin_Stop	Stop value for sweep of large-signal input power; must be a real number	dBm	-20
Pin_Step	Interval for linear sweep of large-signal input power; must be a positive real number	dB	10
GamAng_Start	Start value for angle of output reflection coefficient; must be a real number	deg	-180
GamAng_Stop	Stop value for angle of output reflection coefficient; must be a real number	deg	180
GamAng_Step †	Interval for angle of output reflection coefficient; must be a real number	deg	20
GamMag_Start	Start value for magnitude of output reflection coefficient; must be a non-negative real number	None	0.1
GamMag_Stop	Stop value for magnitude of output reflection coefficient; must be a non-negative real number	None	0.9
GamMag_Step †	Interval for magnitude of output reflection coefficient; must be a non-negative real number	None	0.1
† Only linear sweeps using intervals of GamAng_Step, GamMag_Step are permitted using LoadAmpPull.			

Notes/Equations

- For amplifier designers, the AmpLoadPull and LoadPullSetup components address the issue of output match in one or more frequency bands. This is often investigated via load-pull contours indicating the load impedances that, when presented to the output of an amplifier with a given source impedance and power, cause a certain power to be delivered to the load. The LoadPullSetup component extracts an ADS dataset, given ranges and steps for input power, output reflection coefficient magnitude and output reflection coefficient angle. AmpLoadPull uses this dataset and allows fast behavioral amplifier simulations for all input power and output reflection coefficient values in the specified ranges. The use of this component is highlighted in the example project AmpLoadPull_prj.

2. Although the behavioral data collected via LoadPullSetup is found using Harmonic Balance simulations, the subsequent behavioral amplifier simulations are not restricted to Harmonic Balance. In fact, the behavioral amplifier is assumed to be used for subsequent system verification (BER, ACPR etc. for Tx, Rx) within a Circuit Envelope framework. In such applications, various filters typically eliminate unwanted DC and harmonic components. Therefore, the load-pull suite was not designed to predict such components. This means that
 - for a 1-tone Harmonic Balance simulation at frequency f , only the frequency component at f (fundamental) is retained. All others will be invalid or zero as they are assumed to be filtered later.
 - for a 2-tone Harmonic Balance simulation at frequencies f_1 and f_2 (practically very close), only the frequency components at f_1 and f_2 (fundamentals) and those at $2 \times f_1 - f_2$ and $2 \times f_2 - f_1$ (intermodulation) are retained as these will be very close and cannot be assumed to be filtered. All others will be invalid or zero as they are assumed to be filtered later.
3. LoadPullSetup can be pushed into for a view of the implementation. If necessary, the component can be copied and modified to suit individual needs.
4. The extracted ADS dataset is assigned the name of the extraction design by default.

MixerHBdata (2-Tone HB Mixer)

Symbol

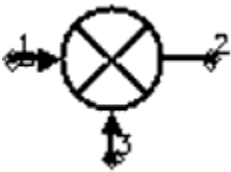

Available in ADS

Parameters

Name	Description	Units	Default
Dataset	Name of dataset for 2-tone harmonic balance mixer generated by MixerHBsetup	None	dataset.ds
RFindexExpr †	RF tone mixing index defined in the MixerHBsetup component	None	Mix(2)

Advanced Design System 2008

	at the time of dataset extraction; typically set to "Mix(2)"		
LOindexExpr †	LO tone mixing index defined in the MixerHBsetup component at the time of dataset extraction; typically set to "Mix(1)"	None	Mix(1)
IFwaveExpr †	IF wave variable defined in the MixerHBsetup component at the time of dataset extraction; typically set to "b2"	None	b2
IMdata ††	Intermodulation data flag: can be -1 or 1 only	None	-1
ConvGain †††	Conversion gain multiplier from RF port (Port 1) to IF port (Port 2)	None	dbpolar(0,0)
SP11 †††	RF port reflection coefficient	None	polar(0,0)
SP12 †††	IF port to RF port leakage coefficient	None	polar(0,0)
SP13 †††	LO port to RF port leakage coefficient	None	polar(0,0)
SP21 †††, ‡	RF port to IF port transmission/leakage coefficient	None	polar(0,0)
SP22 †††	IF port reflection coefficient	None	polar(0,180)
SP23 †††, ‡	LO port to IF port transmission/leakage coefficient	None	polar(0,0)
SP31 †††	RF port to LO port leakage coefficient	None	polar(0,0)
SP32 †††	IF port to LO port leakage coefficient	None	polar(0,0)
SP33 †††	LO port reflection coefficient	None	0
NF	Input double side band noise figure	dB	None

Advanced Design System 2008

NFmin	Minimum double sideband noise figure at Sopt	dB	None
Sopt †††	Optimum Source Reflection for Minimum Noise Figure, use $x+j*y$, $\text{polar}(x,y)$, $\text{dbpolar}(x,y)$ for complex value	None	None
Rn	Equivalent noise resistance; must be a non-negative real number		
Z1	Reference impedance for RF port		
Z2	Reference impedance for IF port		
Z3	Reference impedance for LO port		
P_RFnom ††	Power incident at the RF port; must be manually synchronized with source signal value at this port	dBm	-50
P_LOnom ††	Power incident at the LO port; must be manually synchronized with source signal value at this port	dBm	-5
M_RF ††	Number of RF harmonics to be considered from dataset	None	4
N_LO ††	Number of LO harmonics to be considered from dataset	None	4

† Typically not edited by user. Should be synchronized with expressions registered in dataset created using MixerHBsetup.

† † Set to -1 for lower sideband or 1 for upper sideband. Refer to note 5 for details.

† † † These parameters can be reported in any of the following complex number formats: $x + j*y$, $\text{polar}(x,y)$, $\text{dbpolar}(x,y)$, $\text{vswrpolar}(x,y)$

‡ Transmission/leakage implies that the value of this parameter is used as an additive supplement to gain expressions between RF->IF and LO->IF ports.

‡‡ Refer to note 7 for details.

Notes/Equations

1. MixerHBdata is a data-based system model of a circuit-level mixer. The dataset used by MixerHBdata is generated from the circuit-level mixer by the behavioral extractor component MixerHBsetup (available in the System-Data Models palette). Ports 1, 2 and 3 on MixerHBdata correspond to the RF, IF and LO ports of MixerHBsetup.
2. The extraction process using MixerHBsetup is done at fixed user-supplied RF and LO power levels. MixerHBdata performs linear interpolation along either power axes if the data model-based verification process is done at a different RF or LO power level. Therefore, it is recommended that the data model be used either in a known linear region of operation or cautiously within a narrow input power range if it is necessary to replicate non-linear operation.
3. MixerHBdata can be used in Harmonic Balance, Circuit Envelope, and Transient simulations.
4. MixerHBdata is currently configured to produce IF output with zero phase regardless of the IF output phase represented in the MixerHBsetup extracted dataset.
5. A dataset extracted using the MixerHBsetup component contains both upper and lower sideband harmonics and intermodulation products. By formal definition the upper sideband contains frequencies above the higher of the two mixing frequencies. For example, in a typical RFIC receiver, the center frequency is the RFFreq because LOfreq < RFFreq. In the MixerHBdata component the IMdata parameter is used to prompt the use of only one of these two bands for deriving an internal polynomial model for frequency response. Once this model has been constructed, it is used to represent behavior of both sidebands in the MixerHBdata simulation output.
6. If a 2-tone Harmonic Balance simulation is to be performed on a MixerHBdata component using Freq[1]=LOfreq and Freq[2]=RFFreq in the simulator component, then setting IMdata=-1 selects the lower sideband frequencies and IMdata=1 selects the upper sideband frequencies from the dataset. The harmonics and intermodulation products are defined as $|m \times RFFreq - n \times LOfreq|$ in the lower sideband and $|m \times RFFreq + n \times LOfreq|$ in the upper sideband, where m and n are integers whose absolute values are bounded by $_M_RF_$ and $_N_LO_$ (the maximum harmonic order parameters of the MixerHBdata component).
7. By the convention that $-M_RF \leq m \leq M_RF$ and $-N_LO \leq n \leq N_LO$, and the assumption that M_RF and N_LO are of comparable magnitudes, the difference frequencies $|m \times RFFreq - n \times LOfreq|$ are guaranteed to be lower than RFFreq and the summed frequencies $|m \times RFFreq + n \times LOfreq|$ are guaranteed to be higher than RFFreq. Thus, the IMdata parameter helps in sideband selection and should be assigned values of -1 or 1 only. For proper modeling $_M_RF_$ and $_N_LO_$ of the MixerHBdata component should be set to the value of RForder and LOorder settings of the MixerHBsetup that was used to extract the behavioral dataset.
8. The use of this component is highlighted in the example project MixerHBdata_prj.

MixerHBsetup (2-Tone HB Mixer Setup)

Symbol

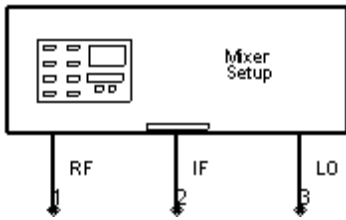

Available in ADS

Parameters

Name	Description	Units	Default
RFfreq	RF frequency. Denotes incoming message signal whether it is intended for up or down conversion; must be a non-negative real number	GHz	1
LOfreq	LO frequency. Denotes frequency of local oscillator or carrier frequency; must be a non-negative real number	GHz	1.1
RFpwr	Power incident at the RF port; must be manually synchronized with source signal value at this port	dBm	-20
LOpwr	Power incident at the LO port; must be manually synchronized with source signal value at this port	dBm	0
RForder	Number of RF harmonics allowed to participating in mixing; must be a positive integer greater than 0	None	10
LOorder	Number of LO harmonics allowed to participating in mixing; must be a positive integer greater than 0	None	10

Notes/Equations

1. MixerHBsetup extracts the behavior of a circuit-level mixer using a Harmonic Balance simulation. The extracted dataset can be subsequently used by the corresponding data-based system model MixerHBdata. Ports RF, IF and LO ports of the MixerHBsetup component correspond to the ports 1, 2 and 3 on the MixerHBdata component.
2. MixerHBsetup can be pushed into for a view of the extractor implementation including access to the built-in Harmonic Balance simulator component. Note that equations and variables of the extractor subcircuit are referenced by name from parameters of the MixerHBdata component. Any user-initiated changes made to a specific instance of MixerHBsetup must be reflected in a complementary instance of MixerHBdata for correct dataset indexing for behavioral modeling.
3. The use of this component is highlighted in the example project MixerHBdata_prj .
4. The extracted ADS dataset is assigned the name of the extraction design by default.

MixerIMT (Obsolete Intermodulation Table Mixer)

Symbols:

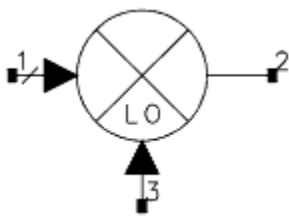

Available in ADS

Parameters

Name	Description	Units	Default
SS_SideBand	Produce UPPER or LOWER sideband at output port for linear analysis.	None	UPPER
ConvGain †	Conversion gain multiplier from RF port (Port 1) to IF port (Port 2).	None	dbpolar(0,0)
SP11 †	RF port reflection	None	polar(0,0)

Advanced Design System 2008

	coefficient.		
SP22 †	IF port reflection coefficient.	None	polar(0,180)
SP33 †	LO port reflection coefficient.	None	0
NF	Input double side band noise figure; must be a non-negative real number.	dB	None
NFmin	Minimum double sideband noise figure at Sopt; must be a positive real number.	dB	None
Sopt †	Optimum source reflection for minimum noise figure; must have magnitude less than 1.0.		
Rn	Equivalent noise resistance; must be a non-negative real number.	Ohm	
R1	Reference impedance for RF port; must be a non-negative real number.	Ohm	
R2	Reference impedance for IF port; must be a non-negative real number.	Ohm	
R3	Reference impedance for LO port; must be a non-negative real number.	Ohm	
InThresh	Voltage threshold for signal input at RF port; must be a positive real number.	V	
LoThresh	Voltage threshold for signal input at LO port; must be a positive real number.	V	
IMT_File	File containing intermodulation table. Accepted formats MDIF: IMT, P2D, S2D.		imtfile.imt
† These parameters can be reported in any of the following complex number formats: $x + j*y$, polar(x,y), dbpolar(x,y), vswrpolar(x,y)			

Notes/Equations

1. This component is included for the convenience of customers who have existing designs with the MixerIMT model. New instances can be accessed by typing MixerIMT into the Component History field in the Schematic window, pressing Enter, and moving your cursor to the drawing area to place it. For new designs, this component should be used only if MixIMT_Data does not provide necessary functionality.
2. MixerIMT does not function in Transient simulations; MixerIMT blocks baseband signals in Circuit Envelope simulations; MixerIMT does not produce intermodulation among RF input tones (refer to [note 9](#)). Replace MixerIMT with MixerIMT2 for these functions.
3. The default value of S12=0 to avoid creating cyclic interdependencies between the RF and IF ports.
4. If no IMT file is referenced, the output (IF) signal is the product of the input RF and LO spectral tones only.
5. If NFmin , Sopt , and Rn are used to characterize noise, the following criteria must be met for a realistic model:

$$\frac{Rn}{Zo} \geq \frac{To(Fmin - 1)|1 + Sopt|^2 (1 - |S_{11}|^2)}{T^4 |1 - Sopt S_{11}|^2}$$

Rn will be reset to a value that meets this criteria if it does not satisfy this condition.

6. Use the function polar(mag,ang), or dbpolar(dB,ang), or VSWRpolar(VSWR, ang) to convert these specifications into a complex number.
7. For an S-parameter or a noise figure sinusoidal ripple, use the function ripple (mag, intercept, period, variable); for example ripple(0-1, 0-1, 10 MHz, Freq).
Example: S21=dbpolar(10+ripple(),0.)
8. This model blocks dc.
9. MixerIMT accepts only O-type IMT files where only single RF on single LO mixing can be specified with implicit assumption about reference RF and LO frequencies. These files are inherently single side banded descriptions of mixer behavior and do not contain IF phase information. For details on various IMT file formats see [Working with Data Files](#) > IMT Format. From such a file, MixerIMT produces intermodulation products at frequencies

$$|m \times LO \setminus +/- n \times Signal|$$

where

$$-M \# m \# M \text{ and } -N \# n \# N$$

Also, M and N are the orders for LO and RF signal frequencies set in the Harmonic Balance or Circuit Envelope simulation controllers.

If there are multiple frequencies at the RF and LO ports, there will be a superposition of the RF-LO intermodulation tones. For example, given the frequencies LO 1 and LO 2 at the LO port, and Signal 1 and Signal 2 at the RF port, there will be intermodulation products at the frequencies:

$$|m \times LO1 +/- n \times Signal1|, |m \times LO1 +/- n \times Signal2|,$$

$$|m \times LO2 +/- n \times Signal1|, |m \times LO2 +/- n \times Signal2|$$

where

$$-M_{RF} \leq m \leq M_{RF} \text{ and } -N_{LO} \leq n \leq N_{LO}$$

There will be no products at $|LO 1 +/- LO 2|$, $|Signal 1 +/- Signal 2|$ or any other RF or LO self-modulation products.

MixerIMT2 (Intermodulation Table Mixer)

Symbols:

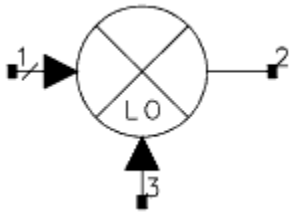

Available in ADS

Parameters

Name	Description	Units	Default
ConvGain †	Conversion gain multiplier from RF port (Port 1) to IF port (Port 2)	None	dbpolar(0,0)
SP11 †	RF port reflection coefficient	None	polar(0,0)
SP12 †	IF port to RF port leakage coefficient	None	polar(0,0)
SP13 †	LO port to RF port leakage coefficient	None	polar(0,0)
SP21 †	RF port to IF port transmission/leakage †† coefficient	None	polar(0,0)
SP22 †	IF port reflection coefficient	None	polar(0,180)
SP23 †	LO port to IF port transmission/leakage †† coefficient	None	polar(0,0)
SP31 †	RF port to LO port leakage	None	polar(0,0)

Advanced Design System 2008

	coefficient		
SP32 †	IF port to LO port leakage coefficient	None	polar(0,0)
SP33 †	LO port reflection coefficient	None	0
NF	Input double side band noise figure; must be a non-negative real number	dB	None
NFmin	Minimum double sideband noise figure at Sopt; must be a positive real number	dB	None
Sopt †	Optimum Source Reflection for Minimum Noise Figure, use $x + j \times y$, polar(x,y), dbpolar(x,y) for complex value	None	None
Rn	Equivalent noise resistance; must be a non-negative real number		
R1	Reference impedance for RF port; must be a non-negative real number		
R2	Reference impedance for IF port; must be a non-negative real number		
R3	Reference impedance for LO port; must be a non-negative real number		
M_RF †††	IMT order for RF port	None	15
N_LO †††	IMT order for LO port	None	15
IMTValueType	IMT value type: enumerated as {dB, dBm}	None	dB
IMT_File	File containing intermodulation table; accepted formats MDIF: IMT, P2D, S2D	None	imtfile.imt

† These parameters can be reported in any of the following complex number formats: $x + j \times y$, polar(x,y), dbpolar(x,y), vswrpolar(x,y)

++ Transmission/leakage implies that the value of this parameter is used as an additive supplement to gain expressions between RF->IF and LO->IF ports.

+++ Must be set to a value less than or equal to the number of harmonics represented in the IMT table. The limit on the number of rows and columns in an IMT table is 15.

Notes/Equations

1. For new designs, this component should be used only if MixIMT_Data does not provide necessary functionality.
2. To use NFmin , Sopt , and Rn to characterize noise, the following condition must be satisfied for a realistic model:

$$\frac{Rn}{Zo} \geq \frac{To(Fmin - 1)|1 + Sopt|^2}{T^4} \frac{(1 - |S_{11}|^2)}{|1 - Sopt S_{11}|^2}$$

If the noise parameters attempt to describe a system that requires negative noise (due to Rn being too small), the negative part of the noise will be set to 0 and a warning message will be issued.

3. Use the function polar(mag,ang), or dbpolar(dB,ang), or vswrpolar(VSWR,ang) to convert these specifications into a complex number.
4. For an S-parameter or a noise figure sinusoidal ripple, use the function ripple (mag, intercept, period, variable); for example ripple(0-1, 0-1, 10 MHz, Freq).
Example: S21=dbpolar(10+ripple(),0.)
5. MixerIMT2 accepts only O-type IMT files where only single RF on single LO mixing can be specified with implicit assumption about reference RF and LO frequencies. These files are inherently single side banded descriptions of mixer behavior and do not contain IF phase information. For details on various IMT file formats see [Working with Data Files](#) > IMT Format.
6. When supplied a signal at frequency Freq_Signal at the RF port and a local oscillator frequency Freq_LO at the LO port, MixerIMT2 produces intermodulation products at all frequencies

$$|m \times \text{Freq_LO} \pm n \times \text{Freq_Signal}|$$

where

$$-M_RF \leq m \leq M_RF \text{ and } -N_LO \leq n \leq N_LO$$

The simulation controller may be set to compute fewer frequency components than shown in the above equation. As a general rule, the values of _M_RF_ and _N_LO_ should be set to the order(s) of RF and LO tones on the simulator component and these values must be less than or equal to the number of rows and columns of the IMT table. The largest IMT table supported by this component is of size 16 x 16.

If there are multiple frequencies at the RF and LO ports, there will be a superposition of the RF-LO intermodulation tones. For example, given the frequencies LO 1 and LO 2 at the LO port, and Signal 1 and Signal 2 at the RF port, there will be intermodulation products at the frequencies:

$$|m \times \text{Freq_LO1} \pm n \times \text{Freq_Signal1}|,$$

$$|m \times \text{Freq_LO1} \pm n \times \text{Freq_Signal2}|,$$

$$|m \times \text{Freq_LO2} \pm n \times \text{Freq_Signal1}|,$$

$$|m \times \text{Freq_LO2} \pm n \times \text{Freq_Signal2}|$$

where

$$-M_RF \leq m \leq M_RF \text{ and } -N_LO \leq n \leq N_LO$$

Note that there will be no products at | LO 1 +/- LO 2|, | Signal 1 +/- Signal 2| and other RF or LO self-modulation products at the output of the mixer.

7. MixerIMT2 can be used in all simulations except for Frequency Converting AC analysis.
8. MixerIMT2 leakage terms are specified in two separate ways: the IMT file entries, and the SPij parameters. For example, LO to IF leakage is given by the (M=1, N=0) term in the IMT file as well as the SP23 parameter. When both specifications are given, the total leakage is given by the complex sum of the two specifications. It is generally advisable to leave SP23=SP13=0; in this case, the LO to IF and the RF to IF leakages are specified by the IMT file.

MixIMT_Data (Multi-RF Intermodulation Table Mixer Data Model)

Symbol

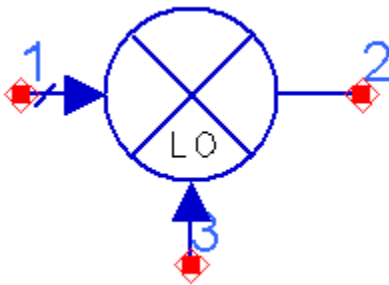

Available in ADS

Parameters

Name	Description	Units	Default
Filename	Name of IMT file to be read		"imtfile.imt"
RFharms[r] †	Number of harmonics of r-th RF input involved in mixing	None	1, r=1
RFfreq[r] †	Fundamental frequency of r-th RF tone	Hz	1.1 GHz, r=1
LOharms	Number of LO harmonics involved in mixing	None	2
LOfreq	Fundamental frequency of	Hz	1.0 GHz

	LO tone		
ZRF	Impedance of RF port	Ohm	polar(50,0)
ZIF	Impedance of IF port	Ohm	polar(50,0)
ZLO	Impedance of LO port	Ohm	polar(50,0)
ConvGain	Voltage conversion gain from RF to IF port	None	dbpolar(0,0)
RFRreflection ††	Wave variable reflection at RF port (S11)	None	polar(0,0)
IFtoRFL leakage ††	Wave variable leakage from IF to RF port (S12)	None	polar(0,0)
LOtoRFL leakage ††	Wave variable leakage from LO to RF port (S13)	None	polar(0,0)
RFtoIF leakage ††	Wave variable leakage from RF to IF port (S21)	None	polar(0,0)
IFreflection ††	Wave variable reflection at IF port (S22)	None	polar(0,0)
LOtoIF leakage ††	Wave variable leakage from LO to IF port (S23)	None	polar(0,0)
RFtoLO leakage ††	Wave variable leakage from RF to LO port (S31)	None	polar(0,0)
IFtoLO leakage ††	Wave variable leakage from IF to LO port (S32)	None	polar(0,0)
LOreflection ††	Wave variable reflection at LO port (S33)	None	polar(0,0)

† Add or remove elements of repeated parameters from dialog box. Ensure that identical number of harmonics and frequencies are specified at all times. †† Reflection and leakage parameters apply to entire spectra present at relevant ports, although RF and LO ports are internally frequency sensitive. See note 6.

Notes/Equations

1. MixIMT_Data is a behavioral mixer component that relies on IMT files. When supplied with an IMT file in O, A or B formats, it emulates mixer behavior by sensing power levels at specified frequencies on the RF and LO ports and reproducing the IF spectrum described in the data file at the output port. Based on the use of the RFFreq[] parameter, it is capable of sensing multiple unrelated fundamental tones at the RF input and generating intermodulation products as specified by multi-tone spurs on file. It senses only the LOfreq tone at the LO input and uses it for determining mixing products.
2. The basic behavior described above can be further modified by specifying non-default voltage conversion gain and port leakage/reflection values. See [Working with Data Files](#) > IMT Format for more information.
3. MixIMT_Data operates on each type of IMT file as follows:

When supplied with an O-type (single-RF, single side banded data with no phase information) file, it generates identical upper and lower side band behavior for any mixing product. When supplying this type of IMT file, the user should ensure that the instance is made sensitive to only the one RF tone of interest. Note that these IMT files do not contain any frequency information. Thus the spur behavior described on file can be reproduced at any RFFreq and LOfreq of interest.

When supplied with an A-type (single-RF, double side banded data with phase information) file, it generates distinct upper and lower side band behaviors as recorded on file. When supplying this type of IMT file, the user should ensure that the instance is made sensitive to only the one RF tone of interest. Since A-type IMT files contain actual values of frequencies and powers, if the RFFreq[1] or LOfreq specified on the behavioral instance does not match the file values, then frequency and power domain interpolation is done to predict a mathematically supportable behavior.

When supplied with a B-type (multi-RF, double side banded data with phase information) file, it generates distinct upper and lower side band behaviors as recorded on file. When supplying this type of IMT file, the user should ensure that the instance is made sensitive to as many RF tones as are present on file. Since B-type IMT files contain actual values of RF frequencies, deviation of the RFFreq[r] from the behavioral instance of file values is not tolerated. Deviation of sensed RF power is allowed. Deviations of LO frequency/power and RF power at established frequencies are responded to by frequency and power domain interpolation as explained in [Working with Data Files](#) > IMT Format.

4. IMT matrices up to $((2 * \text{RFharms}[1] + 1) * \dots * (2 * \text{RFharms}[r] + 1)) \times (\text{LOharms} + 1)$ can be supported by this data model if a table is available on file. Although there is no theoretical upper limit on the number of harmonic indices that can be specified on the data model, the user should establish a cut-off on the number of IF spurs to improve the performance of the underlying harmonic balance simulation. Using the equation for matrix size defined above, it can be verified that a simple three-tone RF input, such as used for adjacent channel power rejection (ACPR) tests, mixed at $\text{RFharm}[] = \{3,2,2\}$ with $\text{LOharm} = 5$ will generate a 175×5 IMT matrix. Lowering the spur precision by 1 on each RF tone will produce a more manageable 45×5 IMT matrix.
5. To understand the use model for this data model see example designs: BehavioralModels > MixIMT_prj > BEH_IMT_*.dsn. Also see related extraction components [MixIMTA_Setup \(Single-RF Intermodulation Table Extractor\)](#) and [MixIMTB_Setup \(Multi-RF Intermodulation Table Extractor\)](#).
6. The internal topology of MixIMT_Data is dynamically generated during simulation. It is possible to trade off the number of spurs generated by the model against simulation performance. Compare resource consumption of example designs BEH_IMT_1R2R_2L.dsn and BEH_IMT_1R1R_2L.dsn from the example project in Note #5. Both designs contain behavioral mixers which read the same data file. However, in the second case the desired degree of distortion is reduced on the second RF tone, resulting in faster simulation without sacrificing accuracy of any desired intermodulation product.
7. The MixIMT_Data model is based on an FDD which responds to exact frequencies of interest supplied on the model instance. When designing a mixer where colliding tones exist at the output spectrum, offset the frequency of one of the input tones by a negligible amount to ensure proper simulation. For example when signal frequency is $\text{RFFreq}[1] = 2.0$ GHz and image frequency is $\text{RFFreq}[2] = 1.4$ GHz, with $\text{LOfreq} = 1.7$ GHz, colliding tones are expected at the difference frequency of 300 MHz. Set $\text{RFFreq}[2] = 1.4$ GHz + $1e-3$ Hz on the data model, the source, as well as the simulator if applicable. See design BEH_IMT_1R2R_2L.dsn in example project BehavioralModels > MixIMT_prj.
8. Applying conversion gain to a system level IMT mixer model is a means of altering the part of the IF spectrum at the IF port that is influenced by RF signal power, without affecting other tones or any other signals at any other ports. Given signal magnitude (in dBm) of RFdBm and phase RFdeg at the RF input, a conversion gain of value dbpolar (CGdB, CGdg) ensures that the internal RF magnitude (in dBm) is altered to $\text{RFdBm} + \text{CGdB}$ and internal RF phase to $\text{RFdeg} + \text{CGdg}$ prior to the mixing process without any impact on the external RF pin. The internal RF magnitude (in dBm) and phase is then used to generate the IF spectrum after appropriate scaling with respect to nominal RF power in the IM table. See design BEH_IMT_2R_4L_ConvGain.dsn in example project BehavioralModels > MixIMT_prj.

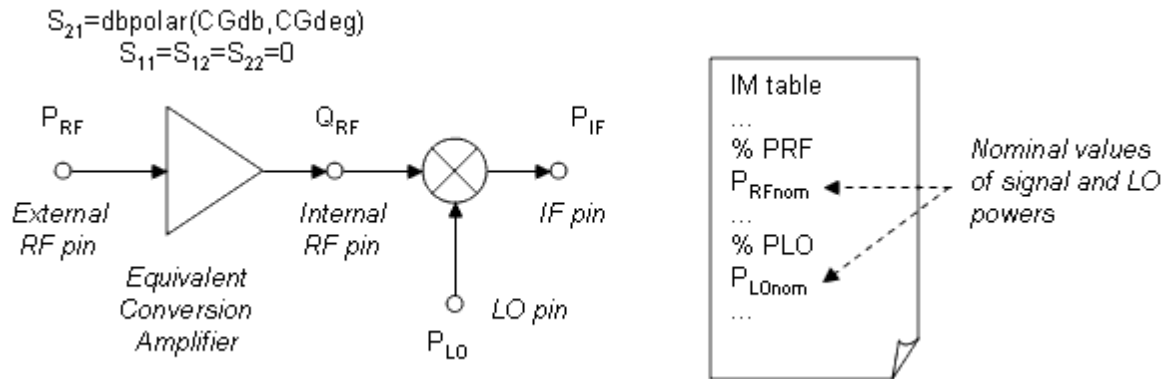

$$Q_{RF} = P_{RF} + dbpolar(CGdb,CGdeg)$$

Estimation of the change in the IF spur at $nLO \times mRF$ due to the supplied signal and conversion gain is computed as ΔP_{IF} such that:

$$dB(\Delta P_{IF} \{n_{LO}, m_{RF}\}) = |m_{RF}| * (P_{RF} + CGdb - P_{RFnom}) + |n_{LO}| * (P_{LO} - P_{LOnom})$$

$$phase(\Delta P_{IF} \{n_{LO}, m_{RF}\}) = m_{RF} * (CGdeg)$$

i Note If there are phase shifts in signals applied at external RF or LO ports, they will impact the phase of the IF spurs in addition to the shifts introduced by the conversion gain parameter.

9. MixIMT_Data accepts all IMT values as representative of absolute magnitude (in dBm) (and phases when applicable) of IF spurs. Therefore, when trying to replace a MixerIMT2 model which was in use in the relative magnitude (in dBm) or dB mode, the corresponding IMT table should be manually converted into a DBM style table. The simplest way to achieve this is to manually edit all IF spurs by adding the amount of the baseline magnitude (in dBm). There are two conventions for baseline power: one being the value of RF signal magnitude (in dBm) at RF input and the other being an expected IF fundamental magnitude (in dBm) at IF port. To address the former convention, the RF signal value is always included in an IMT file and could be applied as an additive to all spurs. If the latter convention is desired, then the absolute value of IF fundamental should be determined and applied to the Mix(1,1) data point in the table. All other spurs will need to be upgraded by the same amount.

MixIMTA_Setup (Single-RF Intermodulation Table Extractor)

Symbol

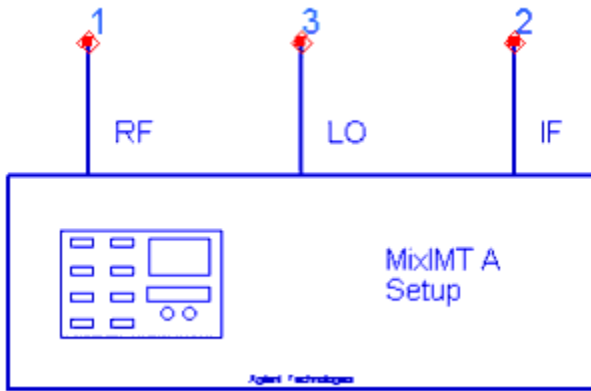

Available in ADS

Parameters

Name	Description	Units	Default
Filename	Name of IMT file to be generated		"imtfile.imt"
RFharms	Number of RF harmonics involved in mixing	None	2
LOharms	Number of LO harmonics involved in mixing	None	2
LOpowr_Start	Nominal or lowest power of LO signal generated	dBm	-10
LOpowr_Stop †	Highest power of LO signal generated (if swept)	dBm	
LOpowr_Step †	Increment in LO signal power (if swept)	dB	
RFpowr_Start	Nominal or lowest power of RF signal generated	dBm	-50
RFpowr_Stop †	Highest power of RF signal generated (if swept)	dBm	
RFpowr_Step †	Increment in RF signal power (if swept)	dB	

LOfreq_Start	Nominal or lowest frequency of LO signal generated	Hz	1.0 GHz
LOfreq_Stop †	Highest frequency of LO signal generated (if swept)	Hz	
LOfreq_Step †	Increment in LO signal frequency (if swept)	Hz	
RFfreq_Start	Nominal or lowest frequency of RF signal generated	Hz	1.1 GHz
RFfreq_Stop †	Highest frequency of RF signal generated (if swept)	Hz	
RFfreq_Step †	Increment in RF signal frequency (if swept)	Hz	
† Values may be specified simultaneously in *_Stop and *_Step parameters, to sweep a corresponding variable. If both are left unspecified, only single point extraction occurs using the nominal value of the *_Start parameter.			

Notes/Equations

1. MixIMTA_Setup is an intermodulation table generating component. When linked to a three pin mixer subcircuit, it is capable of stimulating the RF and LO inputs of the mixer using single-tone sinusoidal RF and LO signals at specified frequencies/powers, while capturing the IF output of the mixer to an intermodulation table (IMT) of specified size. It is possible to capture multiple IM tables to the same data file by sweeping RF and LO signal powers/frequencies.
2. A-type (single RF tone) IMT files contain double side banded complex IF voltage values (dBm,deg), in matrices sized $(2 * RFharms + 1) \times (LOharms + 1)$, where RFharms and LOharms number of harmonics participate in the mixing process. Details of file format are described in [Working with Data Files](#) > IMT Format.
3. Examine the sub-circuit of the extractor to see how the underlying harmonic balance simulation is set-up to achieve mixing. Although there is no theoretical upper limit on the number of harmonic indices that can be specified on this extractor, the user should establish a cut-off on the number of IF spurs to improve the performance of the underlying harmonic balance simulation.
4. To understand the use model for this extractor see example design: BehavioralModels > MixIMT_prj > CKT_IMTA_extraction.dsn. Also see related component [MixIMTB_Setup \(Multi-RF Intermodulation Table Extractor\)](#).

MixIMTB_Setup (Multi-RF Intermodulation Table Extractor)

Symbol

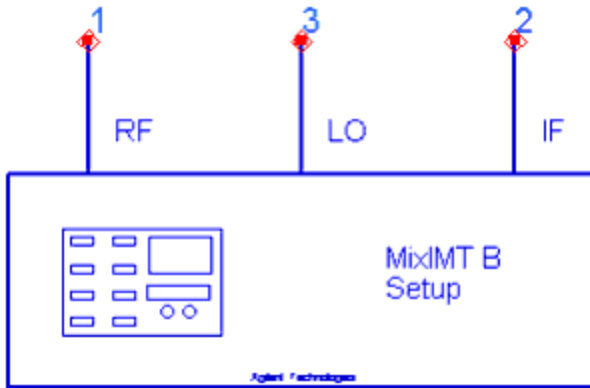

Available in ADS

Parameters

Name	Description	Units	Default
Filename	Name of IMT file to be generated		"imtfile.imt"
RFharms[r] † †	Number of harmonics of the r-th RF input involved in mixing	None	1, r=1
RFfreq[r] † †	Fundamental frequency of r-th RF tone	Hz	1.1 GHz, r=1
RFpowr[r] † †	Power of r-th RF tone	dBm	-50, r=1
LOharms	Number of LO harmonics involved in mixing	None	2
LOfreq_Start	Nominal or lowest frequency of LO signal generated	Hz	1.0 GHz
LOfreq_Stop † †	Highest frequency of LO signal generated (if swept)	Hz	
LOfreq_Step † †	Increment in LO signal frequency (if swept)	Hz	
LOpowr_Start	Nominal or lowest power of	dBm	-10

	LO signal generated		
LOpowr_Stop ††	Highest power of LO signal generated (if swept)	dBm	
LOpowr_Step ††	Increment in LO signal power (if swept)	dB	
<p>† Add or remove elements of repeated parameters from dialog box. Ensure that identical number of harmonics, frequencies and powers are specified at all times. †† Values may be specified simultaneously in *_Stop and *_Step parameters, to sweep a corresponding variable. If both are left unspecified, only single point extraction occurs using the nominal value of the *_Start parameter</p>			

Notes/Equations

- MixIMTB_Setup is an intermodulation table generating component. When linked to a three pin mixer subcircuit, it is capable of stimulating the RF and LO inputs of the mixer using multi-tone sinusoidal RF and LO signals at specified frequencies/powers, while capturing the IF output of the mixer to an intermodulation table (IMT) of specified size. It is possible to capture multiple IM tables to the same data file by sweeping LO signal powers/frequencies.
- B-type (multi-RF tone) IMT files contain double side banded complex IF voltage values (dBm,deg), in matrices sized $[(2 * RFharms[1] + 1) * \dots * (2 * RFharms[r] + 1)] \times (LOharms + 1)$ where RFharms various RF tones and LOharms number of harmonics participate in the mixing process. Details of file format are described in [Working with Data Files](#) > IMT Format.
- Although there is no theoretical upper limit on the number of harmonic indices that can be specified on this extractor, the user should establish a cut-off on the number of IF spurs to improve the performance of the underlying harmonic balance simulation. Using the equation for matrix size defined above, it can be verified that a simple three-tone RF input, such as used for adjacent channel power rejection (ACPR) tests, mixed at $RFharm[] = \{3,2,2\}$ with $LOharm = 5$ will generate a 175×5 IMT matrix. Lowering the spur precision by 1 on each RF tone will produce a more manageable 45×5 IMT matrix.
- To understand the use model for this extractor see example design: BehavioralModels > MixIMT_prj > CKT_IMTA_extraction.dsn. Also see related component [MixIMTA_Setup \(Single-RF Intermodulation Table Extractor\)](#).
- The internal topology of MixIMTB_Setup is generated dynamically during simulation. There is no viewable sub-circuit of this component. To understand the principle of IM table generation, see how the power sources and harmonic balance controller are set up for [MixIMTA_Setup \(Single-RF Intermodulation Table Extractor\)](#), which is more simple.

VCA_Data (Voltage Controlled Amplifier)

Symbol

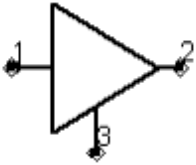

Available in ADS

Parameters

Name	Description	Units	Default
Dataset	Name of dataset generated by VCA_Setup model	None	dataset.ds
InstrumentID	ID of VCA_Setup extractor used to generate dataset	None	X1
iVarN †	Name of Nth multi-dimensional variables $N=\{1,\dots,N\}$; use if present in P2D file	None	None
iValN †	Value of Nth multi-dimensional variables $N=\{1,\dots,N\}$; use real or integer values only	None	None

† If multi-dimensional variables are present in the Dataset, then these variables are required to be listed in iVarN as indicated in note 11 and corresponding values assigned to them using the iValN parameter. Multidimensional VCA datasets are generated using parametric sweeps over the VCA_Setup component.

Notes/Equations

1. VCA_Data is a data-based system model of a circuit-level VCA. The circuit level VCA is characterized by a dataset generated by the system component VCA_Setup. The use of this component is highlighted in the example project VCA_prj.
2. VCA_Data is the most advanced data-based system amplifier. If no special circumstances make AmplifierS2D, AmplifierP2D, AmpH1H2 or AmpLoadPull superior to VCA_Data, the latter model should be used for data-based system modeling of amplifiers. Since the VCA_Data does not have provisions for explicit control of frequency,

order of harmonics or bias voltage at the instance level, it is advised that behavioral simulation and extraction simulation environments be closely matched for reliable modeling.

3. VCA_Setup and VCA_Data work equally well for amplifiers with or without a control voltage. For amplifiers without a control voltage, the control pin should be grounded.
4. VCA_Data is designed for Harmonic Balance or Circuit Envelope system verification (ACPR, BER, etc.) where various filters typically eliminate unwanted frequency components. Therefore, VCA_Data makes no attempt to model harmonic components. This means that for a 1-tone Harmonic Balance simulation at frequency f , only the frequency component at f (fundamental) is retained. All others will be invalid or zero as they are assumed to be filtered later.
For a 2-tone Harmonic Balance simulation at frequencies f_1 and f_2 (practically very close), only the frequency components at f_1 and f_2 (fundamentals) and those at $2 \times f_1 - f_2$ and $2 \times f_2 - f_1$ (intermodulation) are retained. These frequency components are very close and filtering cannot be guaranteed. All other frequency components are invalid or zero, it is assumed that they will be filtered later. Similarly, for a Circuit Envelope simulation, narrowband modulated components around the carrier(s) are retained. All others are invalid or zero, it is assumed they will be filtered later.
VCA_Data will also run in Transient but this is not a recommended simulation controller. Since VCA_Setup is based on Harmonic Balance analysis, the dataset created by VCA_Setup contains steady-state information only. Transient analysis can only predict the correct steady-state response. This likely to result in an incorrect transient response.
5. In order for VCA_Data to produce an accurate model of the circuit-level VCA characterized via VCA_Setup, the Order parameter for VCA_Setup must be large enough to prevent aliasing of higher-order frequency components. For mildly non-linear circuits, an Order of approximately 5 should suffice while a range of 10-15 is recommended for highly non-linear circuits. Provided this criterion is met, the Order parameter for the simulation controller can be very low when using VCA_Data in a Harmonic Balance or Circuit Envelope simulation. Typically, an Order of approximately 3 should suffice for accurate VCA modeling. However, accurate modeling of the other components in the complete system may necessitate the need for a larger value for this parameter.
6. For a circuit-level VCA, the impedances presented by the input, output and control pins are usually highly complicated functions of all state variables within the circuit of which the VCA is part. For a data-based VCA, a simplification is necessary because no information about the environment in which the VCA will be placed is known at the time of extraction. Specifically, VCA_Data presents an input power and control voltage dependent impedance at the input, output and control pins, with the input and control impedances assuming an open-circuit output pin. The input and output impedances are voltage-to-current ratios at RF while the control impedance is a voltage-to-current ratio at DC.
7. Assuming proper sampling, the interpolation properties of VCA_Data are generally good, but occasionally break down near the limits of the ranges to which input power and control voltage were constrained when generating the dataset using VCA_Setup. To safe-guard against such a breakdown, the upper and lower limits of these ranges can be extended about 6 dB in input power and 1 V in control voltage.
8. The extrapolation properties of VCA_Data are very poor. When using VCA_Data, please ensure that input power and control voltage are within the ranges to which input power and control voltage were constrained when generating the dataset using VCA_Setup.
9. VCA_Data does not model noise.
10. VCA_Setup and VCA_Data can be used for simulating an amplifier with an arbitrary swept control parameter, for example, a temperature. Simply convert a 2-pin amplifier dependent on a given parameter, in this case Par , to a 3-pin amplifier with the third pin connected to a grounded DC voltage source whose strength equals Par . By sweeping the control voltage of VCA_Setup in the desired parameter range for Par and subsequently connecting the control pin of VCA_Data to a grounded DC voltage source, Par values in the appropriate range can be selected by setting the strength of this voltage source properly.
11. The response of VCA_Data can be user-selected from a body of a multi-dimensional VCA dataset by specifying the names and values of such variables in the $iVarN$ and $iValN$ parameters prior to behavioral simulation. Details of multi-dimensional VCA dataset generation are discussed in [Notes/Equations](#) in the VCA_Setup component

documentation. If a given multi-dimensional VCA dataset contains "V" variables in the form of external sweeps above the Vcontrol sweep, then the names of these variables need to be assigned to an iVarN parameter of the VCA_Data instance. Although the ordering of these names can be arbitrary relative to the order in the P2D file, the existence and ordering of values in the iVal1 through iValV parameters should always correspond to those in iVar1 through iVarV. If a multi-dimensional variable contained in the VCA dataset is not specified in the iVarN of a VCA_Data instance reading that file, then the simulation will be terminated due to insufficient data for multi-dimensional data indexing. Only real and integer values of multidimensional iVarN are supported.

12. A number of new features have been added to enhance the performance of VCA_Data in the ADS2004A release. Please note that the ADS2004A version of VCA_Data is compatible only with datasets generated by the ADS2004A version of VCA_Setup. If a VCA dataset generated by an earlier version of the extractor model is applied to a new version of the data model, an error message is generated asking the user to re-perform the extraction process prior to behavioral modeling.

VCA_Setup (Voltage Controlled Amplifier Setup)

Symbol

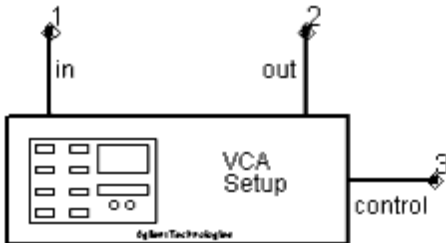

Available in ADS

Parameters

Name	Description	Units	Default
Freq	Fundamental frequency; must be a non-negative real number	GHz	1.0
Order	Order for Harmonic Balance simulation inside extractor; must be an integer greater	None	10

	than 0		
Pin_Start	Start value for sweep of large-signal input power; must be a real number	dBm	-50.0
Pin_Stop	Stop value for sweep of large-signal input power; must be a real number	dBm	20.0
Pin_Step	Interval for linear sweep of large-signal input power; must be a positive real number	dB	10.0
Vcontrol_Start	Start value for sweep of control voltage; must be a real number	V	0.0
Vcontrol_Stop	Stop value for sweep of control voltage; must be a real number	V	1.0
Vcontrol_Step	Interval for linear sweep of control voltage; must be a real number	V	0.1

Notes/Equations

1. VCA_Setup performs a swept control voltage and swept input power simulation of a circuit-level VCA and generates a dataset for subsequent use by the data-based system model VCA_Data. The use of this component is highlighted in the example project VCA_prj .
2. VCA_Setup and VCA_Data work equally well for amplifiers with or without a control voltage. For amplifiers without a control voltage, the control pin should be grounded.
3. In order for VCA_Data to produce an accurate model of the circuit-level VCA characterized via VCA_Setup, the Order parameter for VCA_Setup must be large enough to prevent aliasing of higher-order frequency components. For mildly non-linear circuits, an Order of approximately 5 is sufficient while an Order in the range 10-15 is recommended for highly non-linear circuits.
4. Push into VCA_Setup in a Schematic window for a view of the swept Harmonic Balance simulation controllers. This component can be copied and modified to suit individual needs; typically, this would entail changing the Harmonic Balance controller HB1 to achieve more efficient simulations. For more information, refer to the [Harmonic Balance Simulation](#) manual.
5. When simulating an existing ADS2002 design containing a VCA_Setup instance in the current version of ADS, you must substitute a newer version of VCA_Setup. Failure to do this will result in the generation of warning messages and corruption of the extracted dataset.
6. The extracted ADS dataset is assigned the name of the extraction design by default.
7. It is possible to generate arbitrary multi-dimensional VCA datasets using a VCA_Setup component by applying a chain of ParamSweep controllers in the extraction level design and assigning the SimInstance[1] value of the inner-most sweep to be "Xi.Vcontrol" where "Xi" is the instance name of the VCA_Setup component in use.

Advanced Design System 2008

Vcontrol is a default uppermost sweep inside the extractor subcircuit, hence this assignment bridges the gap between the minimum viable parameters necessary for voltage controlled amplifier modeling and those necessary to adapt such a model for your own application needs. Refer to the example design CKT_VCA_extraction.dsn for an understanding of the multi-dimensional extraction process. The datasets generated by ADS2003C and prior versions of VCA_Setup are significantly different from that generated by the ADS2004A and subsequent versions. To learn how to access the customized multi-dimensional VCA dataset refer to [VCA Data \(Voltage Controlled Amplifier\)](#).