



Agilent Technologies

ADS 2008
January 2008
WiMax Connected Solutions

Advanced Design System 2008

© Agilent Technologies, Inc. 2000-2008

395 Page Mill Road, Palo Alto, CA 94304 U.S.A.

No part of this manual may be reproduced in any form or by any means (including electronic storage and retrieval or translation into a foreign language) without prior agreement and written consent from Agilent Technologies, Inc. as governed by United States and international copyright laws.

Acknowledgments

Mentor Graphics is a trademark of Mentor Graphics Corporation in the U.S. and other countries. Microsoft®, Windows®, MS Windows®, Windows NT®, and MS-DOS® are U.S. registered trademarks of Microsoft Corporation. Pentium® is a U.S. registered trademark of Intel Corporation. PostScript® and Acrobat® are trademarks of Adobe Systems Incorporated. UNIX® is a registered trademark of the Open Group. Java™ is a U.S. trademark of Sun Microsystems, Inc. SystemC® is a registered trademark of Open SystemC Initiative, Inc. in the United States and other countries and is used with permission. MATLAB® is a U.S. registered trademark of The Math Works, Inc.. HSIM2 source code, and all copyrights, trade secrets or other intellectual property rights in and to the source code in its entirety, is owned by Hiroshima University and STARC.

Errata The ADS product may contain references to "HP" or "HPEESOF" such as in file names and directory names. The business entity formerly known as "HP EEsof" is now part of Agilent Technologies and is known as "Agilent EEsof". To avoid broken functionality and to maintain backward compatibility for our customers, we did not change all the names and labels that contain "HP" or "HPEESOF" references.

Warranty The material contained in this document is provided "as is", and is subject to being changed, without notice, in future editions. Further, to the maximum extent permitted by applicable law, Agilent disclaims all warranties, either express or implied, with regard to this manual and any information contained herein, including but not limited to the implied warranties of merchantability and fitness for a particular purpose. Agilent shall not be liable for errors or for incidental or consequential damages in connection with the furnishing, use, or performance of this document or of any information contained herein. Should Agilent and the user have a separate written agreement with warranty terms covering the material in this document that conflict with these terms, the warranty terms in the separate agreement shall control.

Technology Licenses The hardware and/or software described in this document are furnished under a license and may be used or copied only in accordance with the terms of such license. Portions of this product include the SystemC software licensed under Open Source terms, which are available for download at <http://systemc.org/>. This software is redistributed by Agilent. The Contributors of the SystemC software provide this software "as is" and offer no warranty of any kind, express or implied, including without limitation warranties or conditions or title and non-infringement, and implied warranties or conditions merchantability and fitness for a particular purpose. Contributors shall not be liable for any damages of any kind including without limitation direct, indirect, special, incidental and consequential damages, such as lost profits. Any provisions that differ from this disclaimer are offered by Agilent only.

Restricted Rights Legend If software is for use in the performance of a U.S. Government prime contract or subcontract, Software is delivered and licensed as "Commercial computer software" as defined in DFAR 252.227-7014 (June 1995), or as a "commercial item" as defined in FAR 2.101(a) or as "Restricted computer software" as defined in FAR 52.227-19 (June 1987) or any equivalent agency regulation or contract clause. Use, duplication or disclosure of Software is subject to Agilent Technologies' standard commercial license terms, and non-DOD Departments and Agencies of the U.S. Government will receive no greater than Restricted Rights as defined in FAR 52.227-19(c)(1-2) (June 1987). U.S. Government users will receive no greater than Limited Rights as defined in FAR 52.227-14 (June 1987) or DFAR 252.227-7015 (b)(2) (November 1995), as applicable in any technical data.

Contents

- About WiMax Connected Solutions
- - Hardware and Software Requirements
 - Test System Setup
 - - VSA Hardware Setup
 - - VSA Software Configuration Using set File
 - WiMax OFDM Downlink Test
 - -
 - WiMax OFDM Downlink Test Top-Level Design
 - Signal Generation
 - WiMax_OFDM_DL1_to_ESG Schematic
 - WiMax OFDM DL with Long Preamble, FCH, and Data Channels
 - ADS to ESGc Link Setup
 - Waveforms, Power, and CCDF Measurements
 - WiMax_OFDM_DL1_Wav Schematic
 - Spectrum Measurements
 - WiMax_OFDM_DL1_Spec Schematic
 - EVM Measurements
 - WiMax_OFDM_DL1_EVM Schematic
 - Test Settings
 - Test Results
 - WiMax Waveforms, CCDF, and Average Power Measurements
 - WiMax OFDM Downlink Measurement
 - WiMax OFDM Downlink Signal EVM Measurements
 - WiMax OFDM Uplink Test
 - -
 - WiMax OFDM Uplink Test Top-Level Design
 - Signal Generation
 - WiMax_OFDM_UL_to_ESG Schematic
 - WiMax OFDM UL with Short Preamble and Data Channel
 - ADS to ESGc Link Setup
 - Waveforms, Power, and CCDF Measurements
 - WiMax_OFDM_UL_Wav Schematic
 - Spectrum Measurements
 - WiMax_OFDM_UL_Spec Schematic
 - EVM Measurements
 - WiMax_OFDM_UL1_EVM Schematic
 - Test Settings
 - Test Results
 - WiMax Uplink Waveforms, CCDF and Average Power Measurements
 - WiMax OFDM UL Measurement
 - WiMax OFDM UL Signal EVM Measurements
 - Limitations
 - References

About WiMax Connected Solutions

Advanced Design System 2008

Design examples working with Agilent instruments have been created in ADS for testing Worldwide Interoperability for Microwave Access (WiMax) OFDM systems based on the IEEE 802.16-2004 standard.

The designs focus on WiMax OFDM transmission system test. They are a baseline system verification tool for WiMax OFDM designers to evaluate their components, sub-systems, and systems from ADS simulation results; evaluations include waveform, power, CCDF, spectrum, and RCE (EVM) performances.

These designs use ADS Numeric Advanced Comm components, Connection Manager components, and other basic ADS components.

The WiMax connected solutions project demonstrates that ADS enables customers to control signal definition and measurement selection:

- Signal Generation Control Framed signal waveforms for both WiMax OFDM FDD downlink and uplink including preambles, FCH signal header, and data field.
- Signal Measurement Selection Waveforms, spectrum, power, CCDF, and EVM.

Access the designs in ADS from the Main window: File > Examples > Connected_Solutions > WiMax_OFDM_TX_CS_prj.

ADS integrates all test instruments with all software tools as a WiMax test system. After test system setup, one click will execute the WiMax DUT test simulation. Results are automatically loaded to a predefined Data Display window.

Hardware and Software Requirements

- ADS version 2005 or later version on your PC (Win2000, XP)



Note

To run complex designs of WiMax systems, more than 1Gbytes RAM is required.

- Advanced Design System version 2005 or later version. Verify that the Numeric Advanced Comm library and Connection Manager options are included.
- Agilent E4438C Signal Generator (Fireware Revision C.02.20 or higher) with 100 MHz clock rate and 6 GHz carrier frequency.
- Agilent 89641 A Vector Signal Analyzer with 6 GHz carrier for testing 2-6 GHz bands or Agilent 89640A with 2.7 GHz carrier frequency for testing 2-2.7 bands.
- Agilent 89600 software version 5.0 or higher with GPIB and/or LAN interface component model.

Set up the IO library using VISA layer for communicating to instruments.

For more information about Agilent ESG Series of Digital and Analog RF Signal Generator and options, please visit

<http://www.agilent.com/find/ESG>

For more information about Agilent 89600 Series Vector Signal Analyzer and options, please visit

<http://www.agilent.com/find/89600>

Test System Setup

The WiMax test system in ADS will integrate and control the ESG/PSG and VSA/PSA to form the WiMax integrated test system. Test results will be collected and presented with user-friendly displays in ADS.



To set up the test system:

1. Connect ADS to ESGc (or PSG) by LAN or GPIB. The ESGc output is connected to the DUT by an RF cable.
2. The DUT output is connected to Ch1 of VSA (or PSA) by an RF cable.
3. The DUT uses a power supply set up according to the DUT requirements.
4. The VSA output connects the PC through VXI using an IEEE-1394 card. Before testing, verify the VSA hardware connection (see the following figure). Start the VSA software, then select Utilities > Hardware and check settings in the Select Hardware dialog box for VSA hardware; IEEE-1394, RF tuner, and Input module must be marked.

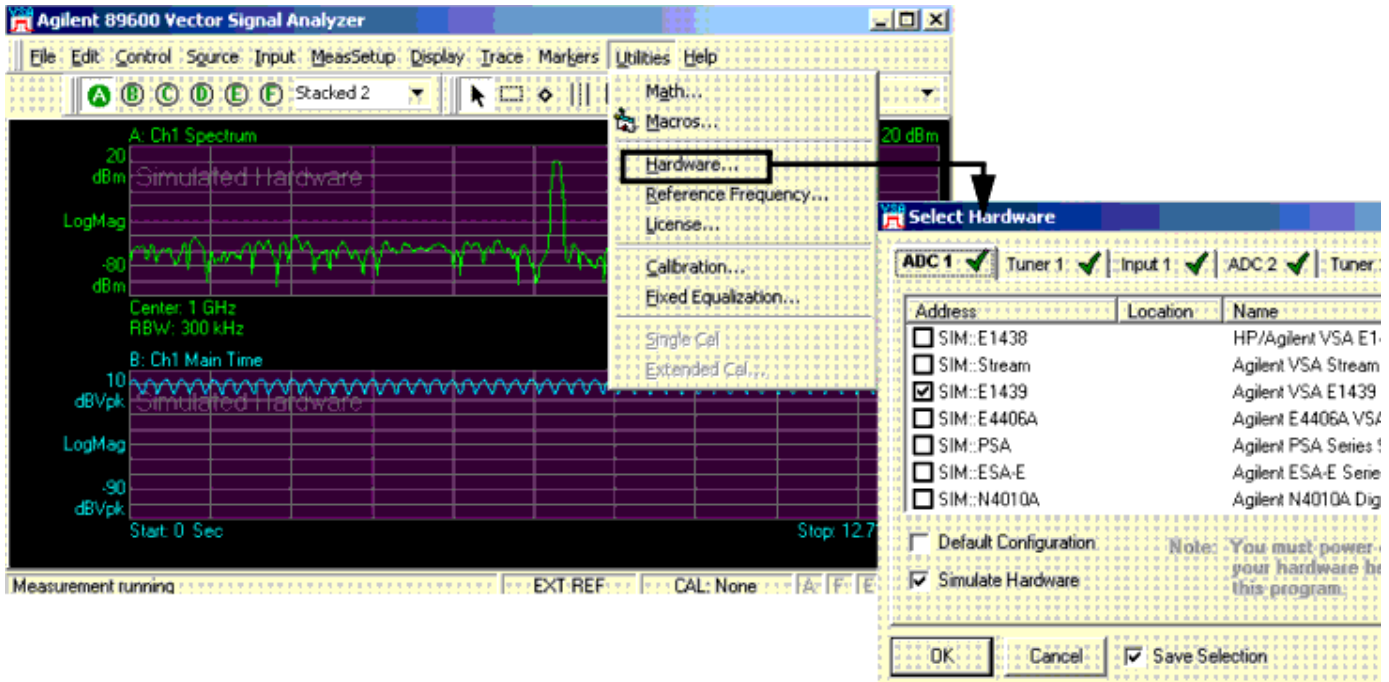

VSA Hardware Setup

- VSA software can be configured using a set file. After configuring the VSA software for measuring WiMax OFDM signals, VSA settings can be saved to a set file by choosing File > Save > Save Setup, and saving the set file as xxx.set in the WiMax_OFDM_TX_CS_prj\data directory.

A number of set files have been stored in the data directory for various power levels, carriers, and signal bandwidths. In WiMax_dl_test.dsn, a default set file wimax_dl_0.set has been loaded for the WiMax DL test. To load other set files for different test cases, choose File > Recall > Recall Setup, select a set file in WiMax_OFDM_TX_CS_prj\data directory.

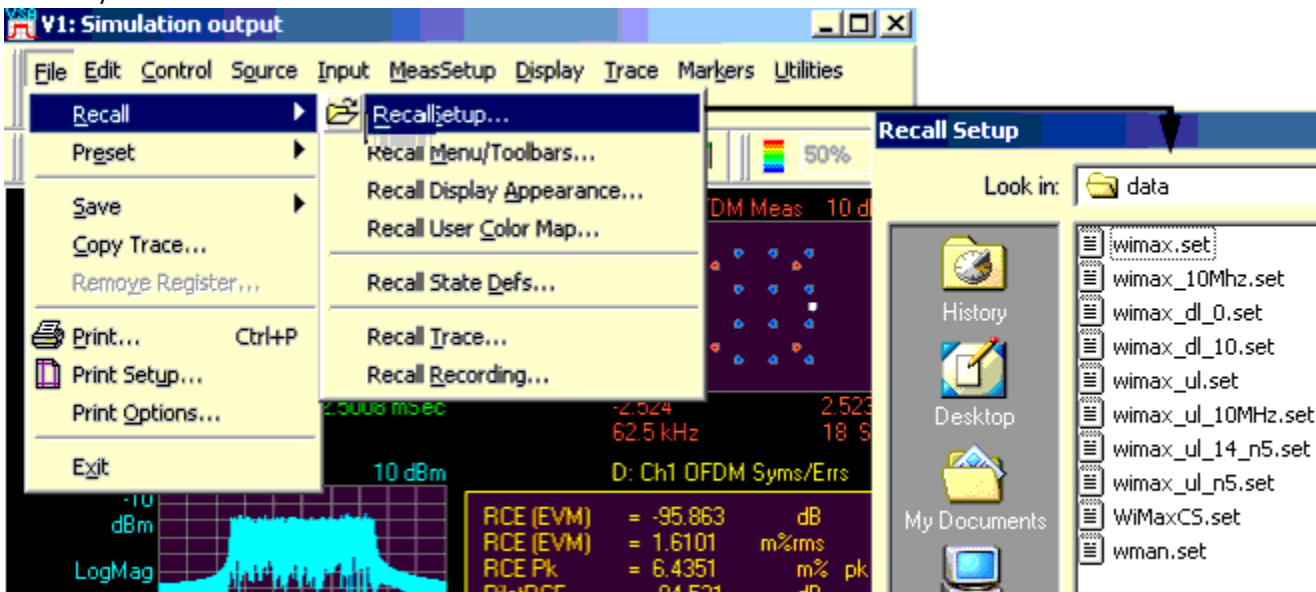

- To use the VSA-ADS link to capture waveforms from VSA then send to ADS, an ADS VSA_89600_Source component is used in all designs to capture WiMax signals from the DUT output. Default parameter settings are based on the example design and a set file. To re-configure the VSA_89600_Source:
 - From the Schematic window, double click the VSA_89600_Source to access the dialog box.
 - From the dialog box, modify VSA_89600_Source parameter settings as required.
 - Click OK to save any changes.

Note
When any parameter settings are changed, the waveform display in the VSA software must be verified and the set file must be saved.

WiMax OFDM Downlink Test

The OFDM downlink top-level design wimax_dl_test.dsn is shown in the following figure.

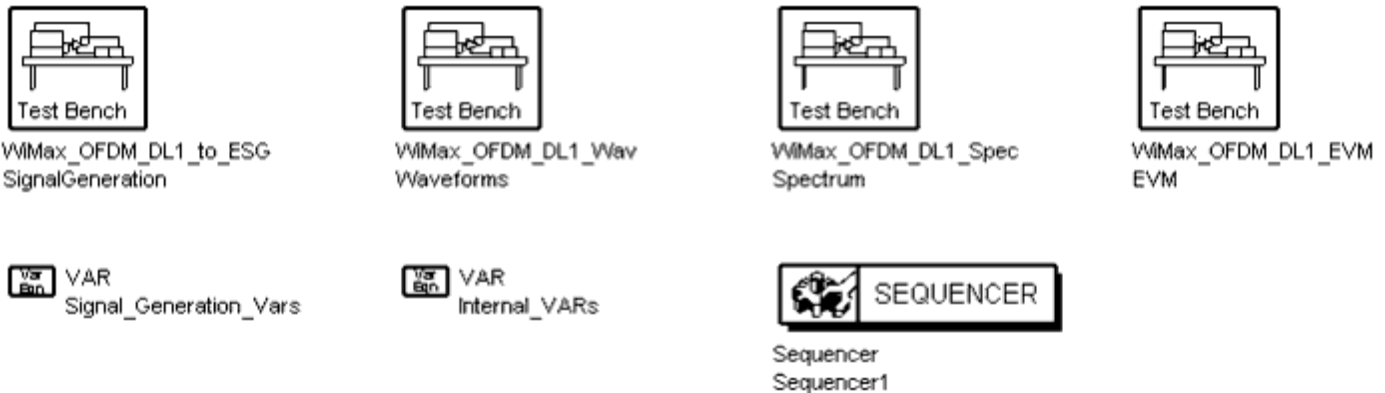

WiMax OFDM Downlink Test Top-Level Design

Four subnet models in this top-level design correspond to four simulation designs (each design is described in subsequent sections):

- WiMax_OFDM_DL1_to_ESG for signal generation
- WiMax_OFDM_DL1_Wav for waveform tests including CCDF and power
- WiMax_OFDM_DL1_Spec for spectrum tests
- WiMax_OFDM_DL1_EVM for EVM tests

The Sequencer controller is used to force signal generation, then testing of waveforms, power, CCDF, spectrum, and

Advanced Design System 2008

EVM, respectively. If the user wants to perform only one (or two) measurements, the unwanted measurement(s) can be deactivated; WiMax_OFDM_DL1_to_ESG and the wanted measurement(s) will remain activated.

Key signal generation parameters for the test signal can be set by the user in the VAR Signal_Generation_Vars block. These parameters include:

- FSource for specifying the RF carrier frequency.
- SourcePower for the source output power in dBm or W.
- Bandwidth for specifying system bandwidth. Based on IEEE 802.16-2004 standard these bandwidths are supported: 1.25 MHz, 1.5 MHz, 1.75 MHz, 2.5 MHz, 2.75 MHz, 3 MHz, 3.5 MHz, 5 MHz, 5.5 MHz, 6 MHz, 7MHz, 10 MHz, 11 MHz, 12 MHz, 15 MHz, 14 MHz, 15 MHz, 20 MHz, 24 MHz and 28 MHz.
- Rate_ID specifies the data modulation and channel coding types. The following table lists Rate_ID parameters of 802.16d associated with coding rate per modulation. For example for Rate_ID=3, modulation type is specified as 16-QAM and the overall coding rate is 1/2.
- DataLength sets the number of data bytes in a burst. There are 8 bits per byte.
- OversamplingOption sets the oversampling ratio of 802.16d RF signal source. Options from 0 to 4 result in oversampling ratio 1, 2, 4, 8, 16 where oversampling ratio = 2^{OversamplingOption}. Other OversamplingOption values are not supported.
If OversamplingOption < 0, then set OversamplingOption=0.
If OversamplingOption >4, then set OversamplingOption=4.
If the oversampling ratio = 2² = 4 and the simulation RF bandwidth is larger than the system bandwidth by a factor of 4 (e.g. for Bandwidth=20 MHz, the simulation RF bandwidth = 20 MHz × 4 = 80 MHz).
The FFT size is determined by OversamplingOption. FFTsize=256 × 2^{OversamplingOption}. When OversamplingOption=0, 1,2,3,4, the FFTsize=256, 512, 1024, 2048, and 4096.
- IdleInterval specifies the idle interval between two consecutive bursts when generating an 802.16d signal source.
- GuardInterval sets the cyclic prefix in an OFDM symbol. The value range of GuardInterval is [0.0,1.0]. The cyclic prefix is a fractional ratio of the IFFT length. 802.16d defines GuardInterval=1/32,1/16,1/8,1/4 of the useful OFDM symbol time.

Rate_ID	Modulation RS-CC Rate
0	BPSK 1/2
1	QPSK 1/2
2	QPSK 3/4
3	16-QAM 1/2
4	16-QAM 3/4
5	64-QAM 2/3
6	64-QAM 3/4
7-15	(not used)

Signal Generation

The schematic for WiMax_OFDM_DL1_to_ESG SignalGeneration is shown in the following figure. This design includes a

WiMax OFDM downlink signal source WMAN_16dRF to generate the test signal.

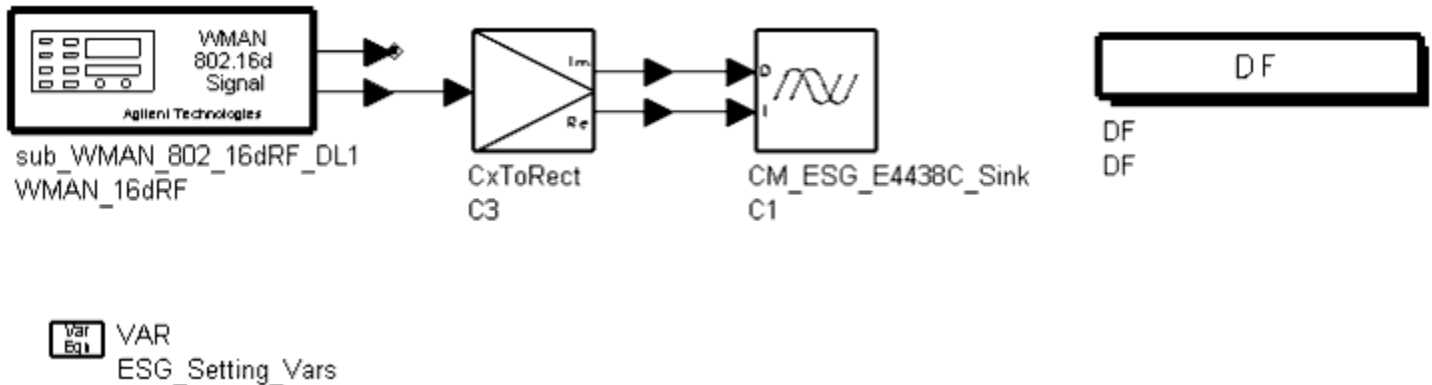

WiMax_OFDM_DL1_to_ESG Schematic

The schematic for signal source WMAN_16dRF is shown in the following figure. In this design, the downlink signal starts with the long preamble that is used for synchronization. The long preamble includes two OFDM symbols: a 4x64 sequence and a 2x128 sequence. The long preamble is followed by an FCH burst with one OFDM symbol. The FCH contains DL_Frame_Prefix to specify burst profile. WiMax data follows the FCH. In the data field, only one data type is specified for ease of comparing the tested RCE results to the standard RCE, which is defined by IEEE 802.16-2004 under the condition of only one burst type for each Rate_ID.

CM_ESG_4438C_Sink is used to download the WiMax signal to ESGc.

To set up ESGc through the connection manager (see [ADS to ESGc Link Setup](#)):

1. From the Schematic window, double click the CM_ESG_4438C_Sink component to access the parameter dialog box. Set parameters in the dialog box as necessary; ESGc settings will then be based on these values.
2. In the parameter dialog box choose Select Instrument. Locate the ESGc instrument in the instrument dialog box and click OK. ADS will be connected to the ESGc.

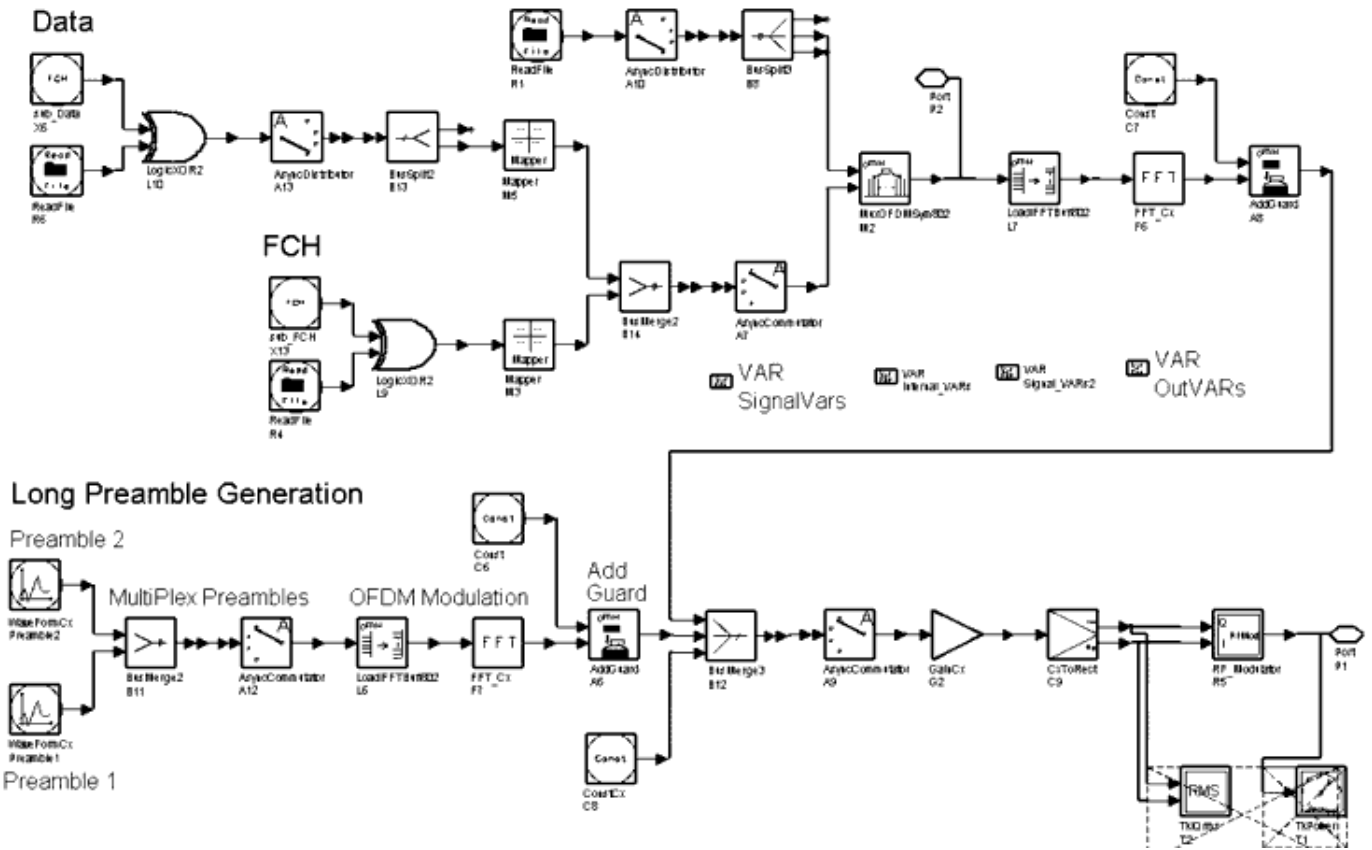

WiMax OFDM DL with Long Preamble, FCH, and Data Channels

Push into Info to read local information

WIMAX 802.16-2004 Design Information

WMax_Esg_Info

W

ESG_Setting_Var
 NumOfSubFrames=10
 StopNumberOfSubFrames=5

Agilent ESG Vector Signal Generators:2

CM_ESG_E4438C_Sink

Instance Name [name{<start:stop>}]
 C1

Select Parameter

Instrument=1[GPIB0:20:INSTR1]loc
 Start=0
 Stop=Stop
 Frequency=2400 MHz
 Amplitude=5
 ARBRef=Internal
 ARBRefFreq=10e6 Hz
 IQModFilter=through
 SampleCk=64 MHz
 FileName=\'WMaxDL\'
 DownloadMode=download_to_VAR
 AutoScale=YFS

Instrument Identifier
 STR[localhost]4790

Select Instrument

Remote Instrument Explorer - port 47

Server localhost:4790 Refresh

VISA Resource Instrument ID
 ASRL1:INSTR
 ASRL4:INSTR
 GPIB0:20:INSTR

Waveforms, Power, and CCDF Measurements

The schematic for WiMax_OFDM_DL1_Wav to measure WiMax signal waveforms, power, and CCDF is shown in WiMax_OFDM_DL1_Wav Schematic.

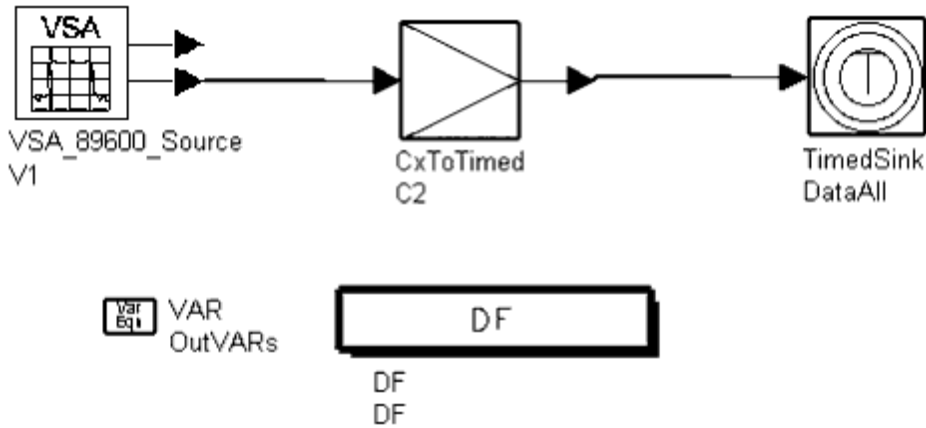

WiMax_OFDM_DL1_Wav Schematic

VSA_89600_Source is used for capturing the WiMax signal from the DUT output. (To configure this source, double click on VSA_89600_Source in the Schematic window for access to the dialog box.) CxToTimed converts the captured complex signal to a timed signal.

TimedSink is used for measuring the timed waveforms.

The VAR OutVARs block is used in the design to enable signal parameters in the Data Display window; these parameters are specified by the user in the SignalGenerationVars block in the top-level design.

Spectrum Measurements

The schematic for WiMax_OFDM_DL1_Spec to measure WiMax signal spectrum is shown in WiMax_OFDM_DL1_Spec Schematic.

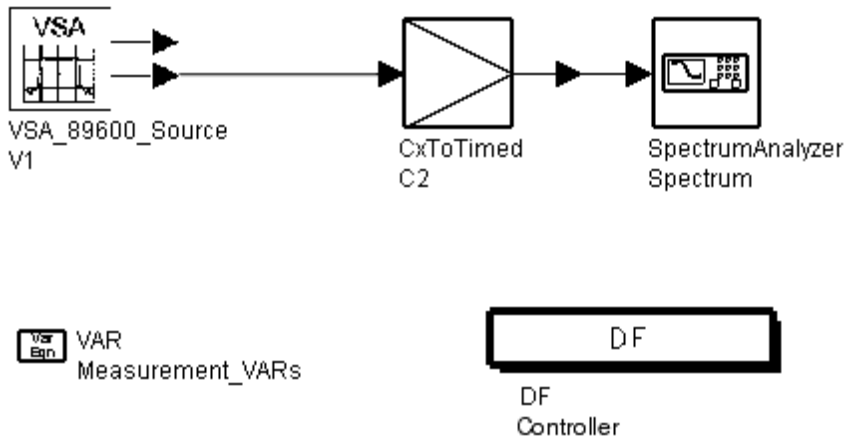

WiMax_OFDM_DL1_Spec Schematic

VSA_89600_Source is used for capturing the WiMax signal from the DUT output. (To configure this source, double click on VSA_89600_Source in the Schematic window for access to the dialog box.) CxToTimed converts the captured complex signal to a timed signal. SpectrumAnalyzer is then used for measuring the spectrum.

EVM Measurements

The schematic for WiMax_OFDM_DL1_EVM to measure WiMax EVM is shown in WiMax_OFDM_DL1_EVM Schematic.

This design measures the WiMax signal relative constellation error (RCE), which is the same as error vector magnitude (EVM) in dB.

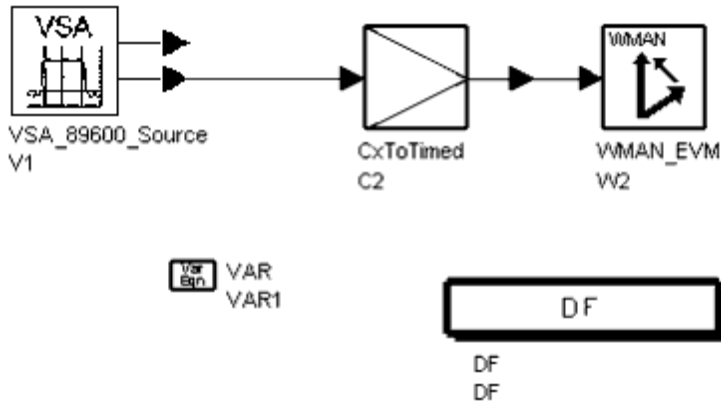

WiMax_OFDM_DL1_EVM Schematic

VSA_89600_Source is used for capturing the WiMax signal from the DUT output. (To configure this source, double click on VSA_89600_Source in the Schematic window for access to the dialog box.) CxToTimed converts the captured

complex signal to a timed signal.

WMAN_EVM is used for measuring the WiMax downlink EVM.

Test Settings

Agilent Demo PA ATF 501P8 with 10 dB gain is used as the DUT. Default test parameter settings are listed here.

- FSource: 2.4 GHz
- SourceR: 50 Ohm
- Source Power: 1 dBm
- Bandwidth: 28 MHz
- Rate_ID: 3
16-QAM, coded block size 48, uncoded block size 96, overall coding rate 1/2
- Data Length: 256
- FFT size: 512
- DL Frame Time: 100 us
- Guard Interval: 1/4
- Idle Interval: 100 us
- Data Sub Carriers: 200
- Pilot Carriers: 8
- Measured Frames: 2

Test Results

After simulation, test results will be automatically saved and displayed by predefined dds files.

WiMax Waveforms, CCDF, and Average Power Measurements shows the waveforms (top, left to right) for Preamble1 (4x64 sequence), Preamble2 (2x128 sequence), Signal Header, and Data as displayed in the Data Display window.

To correctly measure the CCDF and average power, two markers are used to specify the measured range. In general, for these two measurements the user needs to adjust the marker for the non-zero region of a signal burst. Marker m1 also provides information about the test signal delay; delay information is also used for displaying the waveform properly in the top waveform.

Test signal parameters are listed for the user's reference.

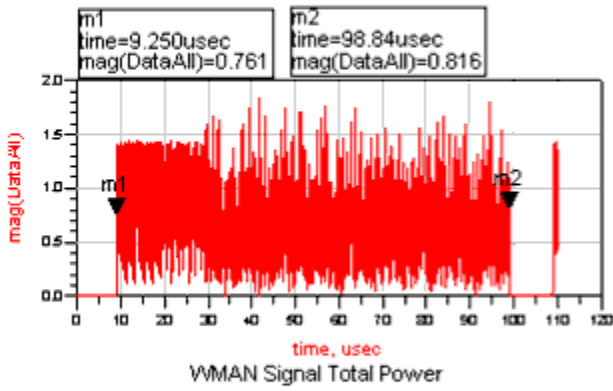
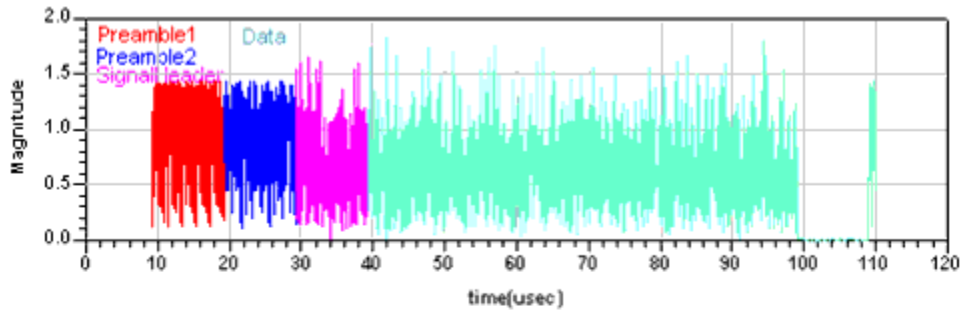

RF_Power_dBm	8.039430
--------------	----------

Note: Use Markers, m1, m2 select a section of data for measuring CCDF and total Power

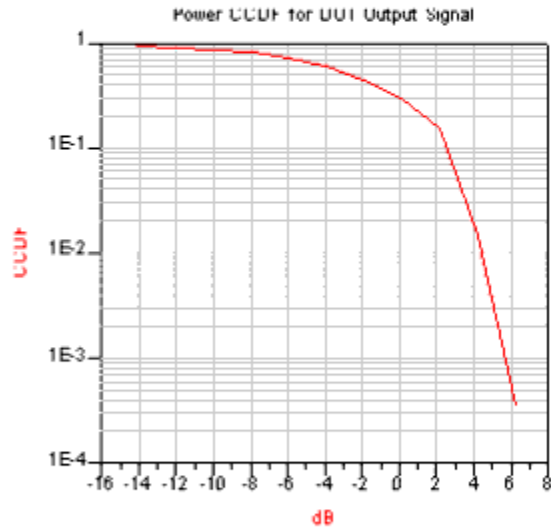

WIMAN OFDM DL Signal Source Parameters

RateID	RF_F Source/TMHz	Source_Power_dBm	RF_Bandwidth/TMHz	...SymbolTime/Tusec	FrameTime/Tmsec
3.000	2400.000	1.000	28.000	10.000	0.100

WiMax Waveforms, CCDF, and Average Power Measurements

WiMax OFDM Downlink Measurement shows the spectrum as displayed in the Data Display window. Test signal parameters including source carrier, signal bandwidth, and signal power are listed. The spectrum measured matches the user specifications: carrier is 2.4 GHz and Bandwidth is 28 MHz.

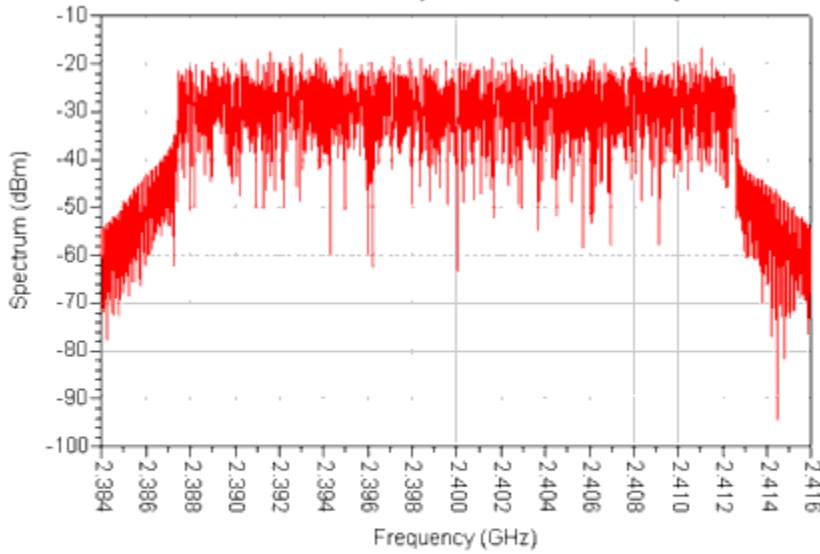

WiMax OFDM DL Signal Source Parameters

RateID	RF_FSource/1MHz	RF_Power_dBm	RF_Bandwidth/1MHz	..._SymbolTime/1usec	FrameTime/1msec
3.000	2400.000	8.039	28.000	10.000	0.100

WiMax OFDM Downlink Measurement

The EVM measurement is very important. WiMax OFDM Downlink Signal EVM Measurements shows the results from the Data Display window. The IEEE 802.16-2004 specification for RCE is listed. The RCE test result is reported with respect to the corresponding standard value. (Failed or Passed are reported based on the comparison.) The table reports different types of EVM values.

Burst Type	BPSK-1/2	QPSK-1/2	QPSK-3/4	16_QAM-1/2	16_QAM-3/4	64-QAM-2/3	64-QAM-3/4
RCE (dB)	-13.0	-16.0	-18.5	-21.5	-25.0	-28.5	-31.0

RCE Standard in dB

-21.500

Test result for RCE in dB

-40.948

Test is **Passed**

RCE (%), Pick RCE, Pilot RCE and Frequency Error (Hz)

Index	RCErms_percent	RCEpk_percent	PilotRCE_dB	FrequencyError_Hz
0	0.897	2.583	-41.225	14.321

WiMax OFDM Downlink Signal EVM Measurements

WiMax OFDM Uplink Test

The OFDM uplink connected solutions top-level design wimax_ul_test.dsn is shown in WiMax OFDM Uplink Test Top-Level Design.

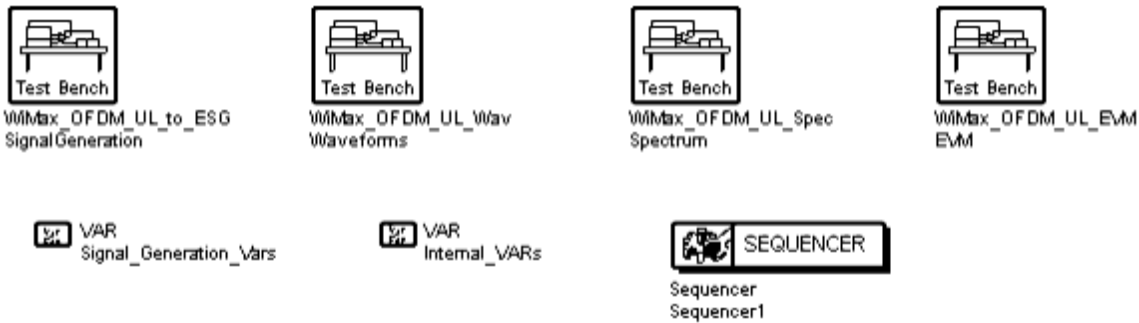

WiMax OFDM Uplink Test Top-Level Design

Four subnet models in this top-level design correspond to four simulation designs (each design is described in subsequent sections):

- WiMax_OFDM_UL_to_ESG.dsn for signal generation
- WiMax_OFDM_UL_Wav.dsn for waveform tests including CCDF and power
- WiMax_OFDM_UL_Spec.dsn for spectrum tests
- WiMax_OFDM_UL_EVM.dsn for EVM tests

The Sequencer controller is used to force signal generation, then testing of waveforms, power, CCDF, spectrum, and EVM, respectively. If the user wants to perform only one (or two) measurements, the unwanted measurement(s) can be deactivated; WiMax_OFDM_UL_to_ESG and the wanted measurement(s) will remain activated.

Key signal generation parameters for the test signal can be set by the user in the VAR Signal_Generation_Vars block. These parameters include:

- FSource for specifying the RF carrier frequency.
- SourcePower for the source output power in dBm or W.
- Bandwidth for specifying system bandwidth. Based on IEEE 802.16-2004 standard these bandwidths are supported: 1.25 MHz, 1.5 MHz, 1.75 MHz, 2.5 MHz, 2.75 MHz, 3 MHz, 3.5 MHz, 5 MHz, 5.5 MHz, 6 MHz, 7MHz, 10 MHz, 11 MHz, 12 MHz, 15 MHz, 14 MHz, 15 MHz, 20 MHz, 24 MHz, and 28 MHz.
- Rate_ID specifies the data modulation and channel coding types. [OFDM Rate ID Encodings](#) lists Rate_ID parameters of 802.16d associated with coding rate per modulation. For example for Rate_ID=3, modulation type is specified as 16-QAM and the overall coding rate is 1/2.
- DataLength sets the number of data bytes in a burst. There are 8 bits per byte.
- OversamplingOption sets the oversampling ratio of 802.16d RF signal source. Options from 0 to 4 result in oversampling ratio 1, 2, 4, 8, 16 where oversampling ratio = 2^{OversamplingOption}. Other OversamplingOption values are not supported.

If OversamplingOption < 0, then set OversamplingOption=0.

If OversamplingOption >4, then set OversamplingOption=4.

If the oversampling ratio = 2 2 = 4 and the simulation RF bandwidth is larger than the system bandwidth by a factor of 4 (e.g. for Bandwidth=20 MHz, the simulation RF bandwidth = 20 MHz × 4 = 80 MHz).

The FFT size is determined by OversamplingOption. FFTsize=256 × 2OversamplingOption. When OversamplingOption=0, 1,2,3,4, the FFTsize=256, 512, 1024, 2048, and 4096.

- IdleInterval specifies the idle interval between two consecutive bursts when generating an 802.16d signal source.
- GuardInterval sets the cyclic prefix in an OFDM symbol. The value range of GuardInterval is [0.0,1.0]. The cyclic prefix is a fractional ratio of the IFFT length. 802.16d defines GuardInterval=1/32,1/16,1/8,1/4 of the useful OFDM symbol time.

Rate_ID	Modulation RS-CC Rate
0	BPSK1/2
1	QPSK 1/2
2	QPSK 3/4
3	16-QAM 1/2
4	16-QAM 3/4
5	64-QAM 2/3
6	64-QAM 3/4
7-15	(not used)

Signal Generation

The schematic for WiMax_OFDM_UL_to_ESG SignalGeneration is shown in WiMax_OFDM_UL_to_ESG Schematic. This design includes a WiMax OFDM uplink signal source WMAN_16dRF to generate the test signal.

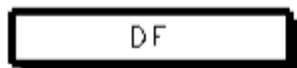
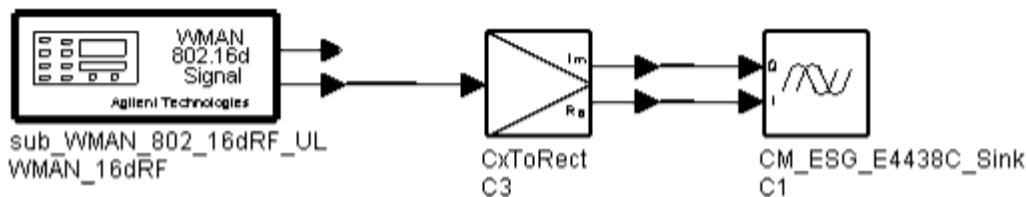

DF
DF

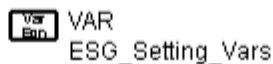

The schematic for signal source WMAN_16dRF is shown in [WiMax OFDM UL with Short Preamble and Data Channel](#). In this design, the downlink signal starts with short preamble that is used for synchronization. The short preamble includes one OFDM symbol that is a 2x128 sequence. The short preamble is followed by WiMax data.

In the data field, only one data type of bursts is specified for ease of comparing the tested RCE results to the standard RCE, which is defined by the IEEE 802.16-2004 under the condition of only one burst type for each Rate_ID.

CM_ESG_4438C_Sink is used to download the WiMax signal to ESGc.

To set up ESGc through the connection manager (see [ADS to ESGc Link Setup](#)):

1. From the Schematic window, double click the CM_ESG_4438C_Sink component to access the parameter dialog box. Set parameters in the dialog box as necessary; ESGc settings will then be based on these values.
2. In the parameter dialog box click Select Instrument. Locate the ESGc instrument in the instrument dialog box and click OK. ADS will be connected to the ESGc.

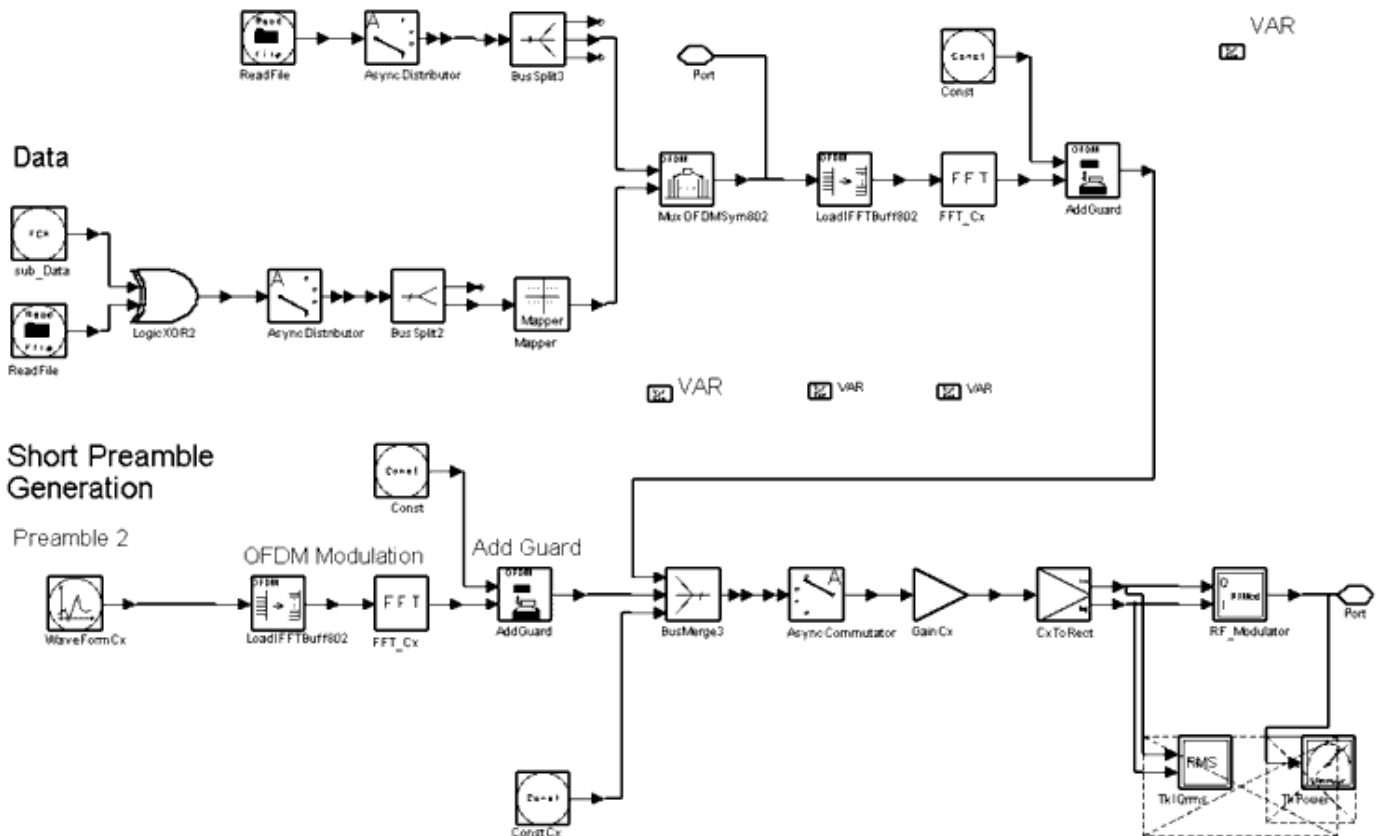

WiMax OFDM UL with Short Preamble and Data Channel

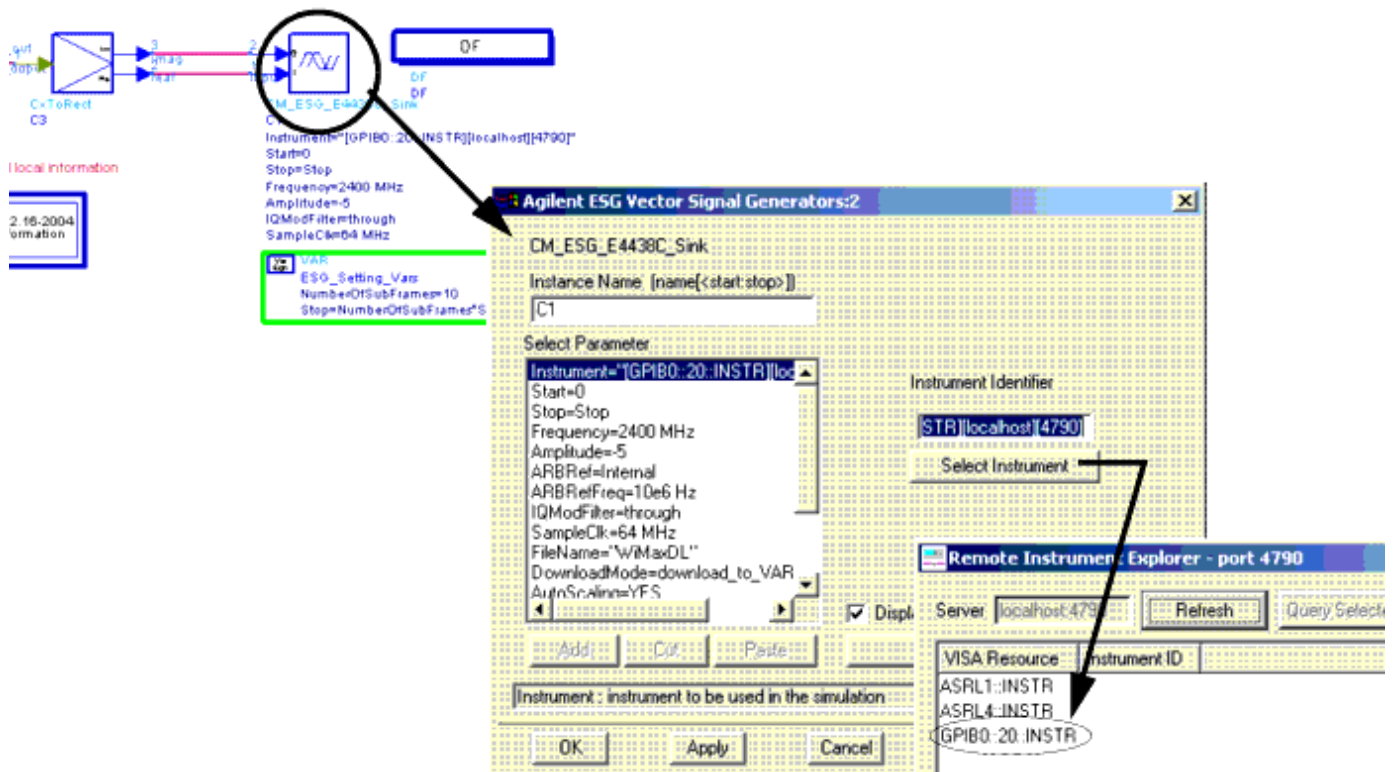

ADS to ESGc Link Setup

Waveforms, Power, and CCDF Measurements

The schematic for WiMax_OFDM_UL_Wav to measure WiMax signal waveforms is shown in WiMax_OFDM_UL_Wav Schematic.

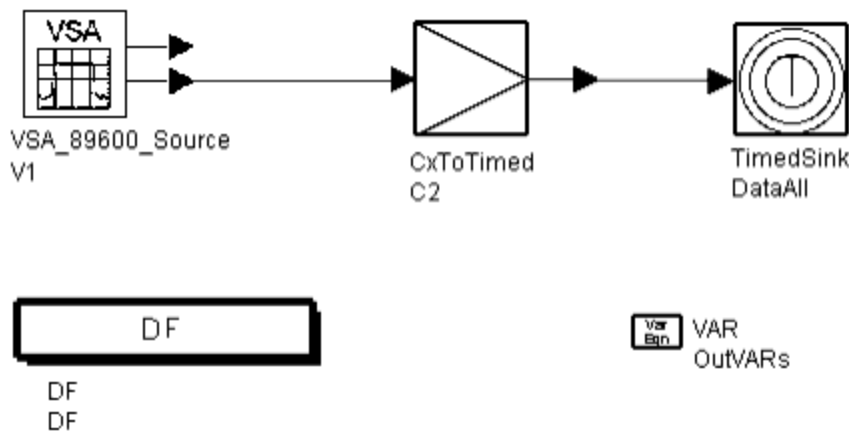

WiMax_OFDM_UL_Wav Schematic

VSA_89600_Source is used for capturing the WiMax signal from the DUT output. (To configure this source, double click on VSA_89600_Source in the Schematic window for access to the dialog box.) CxToTimed converts the captured complex signal to a timed signal.

TimedSink is used to collect data for measuring the waveforms, power, and CCDF.

The OutVARs block is used in the design to enable signal parameters shown in the Data Display window; these parameters are specified by the user in the Signal_Generation_Var block in the top-level design.

Spectrum Measurements

The schematic for WiMax_OFDM_UL_Spec to measure WiMax signal spectrum is shown in WiMax_OFDM_UL_Spec Schematic.

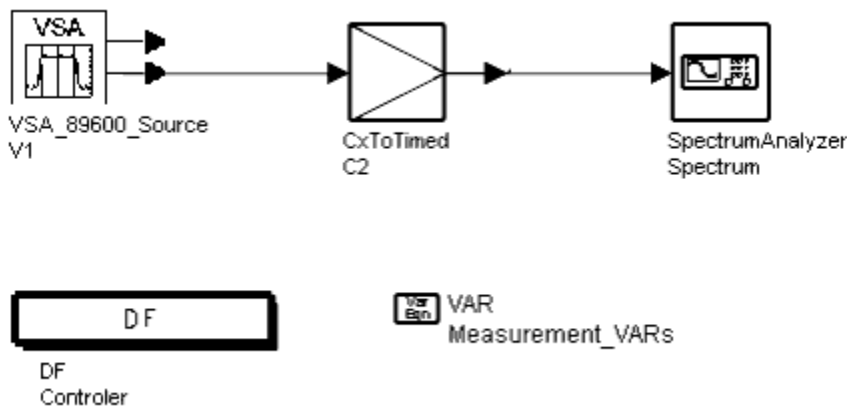

WiMax_OFDM_UL_Spec Schematic

VSA_89600_Source is used for capturing the WiMax signal from the DUT output. (To configure this source, double click on VSA_89600_Source in the Schematic window for access to the dialog box.) CxToTimed converts the captured complex signal to a timed signal. SpectrumAnalyzer is used for measuring the spectrum.

EVM Measurements

The schematic for WiMax_OFDM_UL1_EVM is shown in WiMax_OFDM_UL1_EVM Schematic.

This design measures WiMax signal relative constellation error (RCE), which is the same as error vector magnitude (EVM) in dB.

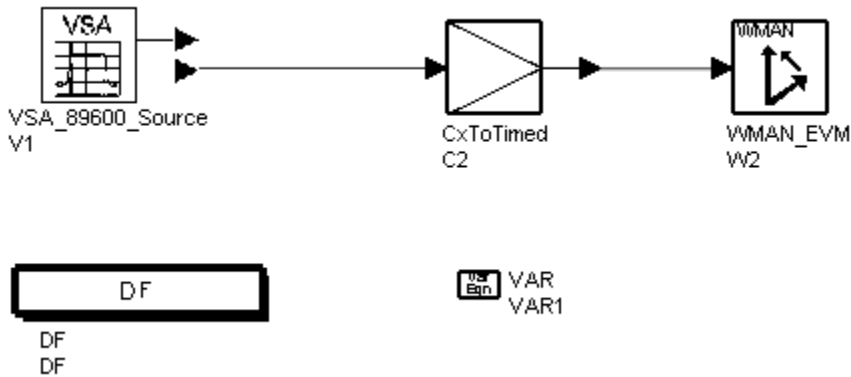

WiMax_OFDM_UL1_EVM Schematic

VSA_89600_Source is used for capturing the WiMax signal from the DUT output. (To configure this source, double click on VSA_89600_Source in the Schematic window for access to the dialog box.) CxToTimed converts the captured complex signal to a timed signal.

WMAN_EVM is used for measuring the WiMax EVM.

Test Settings

An Agilent Demo MGA amplifier with 15 dB gain is used as the DUT. Default test parameter settings are:

- FSource: 2.4 GHz
- SourceR: 50 Ohm
- Source Power: -20 dBm
- Bandwidth: 28 MHz
- Rate_ID: 3
16-QAM, coded block size 48, uncoded block size 96, overall coding rate 1/2
- Data Length: 256
- FFT size: 512
- DL Frame Time: 100 us
- Guard Interval: 1/4
- Idle Interval: 100 us
- Data Sub Carriers: 200
- Pilot Carriers: 8
- Measured Frames: 2

Test Results

After simulation, test results will be automatically saved and displayed by predefined dds files. [WiMax Uplink Waveforms, CCDF and Average Power Measurements](#) shows the waveforms for the Preamble (2x128) sequence and Data as displayed in the Data Display window.

To correctly measure the CCDF and average power, two markers are used to specify the measured range. In general, for these two measurements the user needs to adjust the marker for the framed data in non-zero region of the signal burst. Marker m1 also provides information about the test signal delay; delay information is also used for displaying the waveform properly in the top waveform.

Test signal parameters are listed for the user's reference.

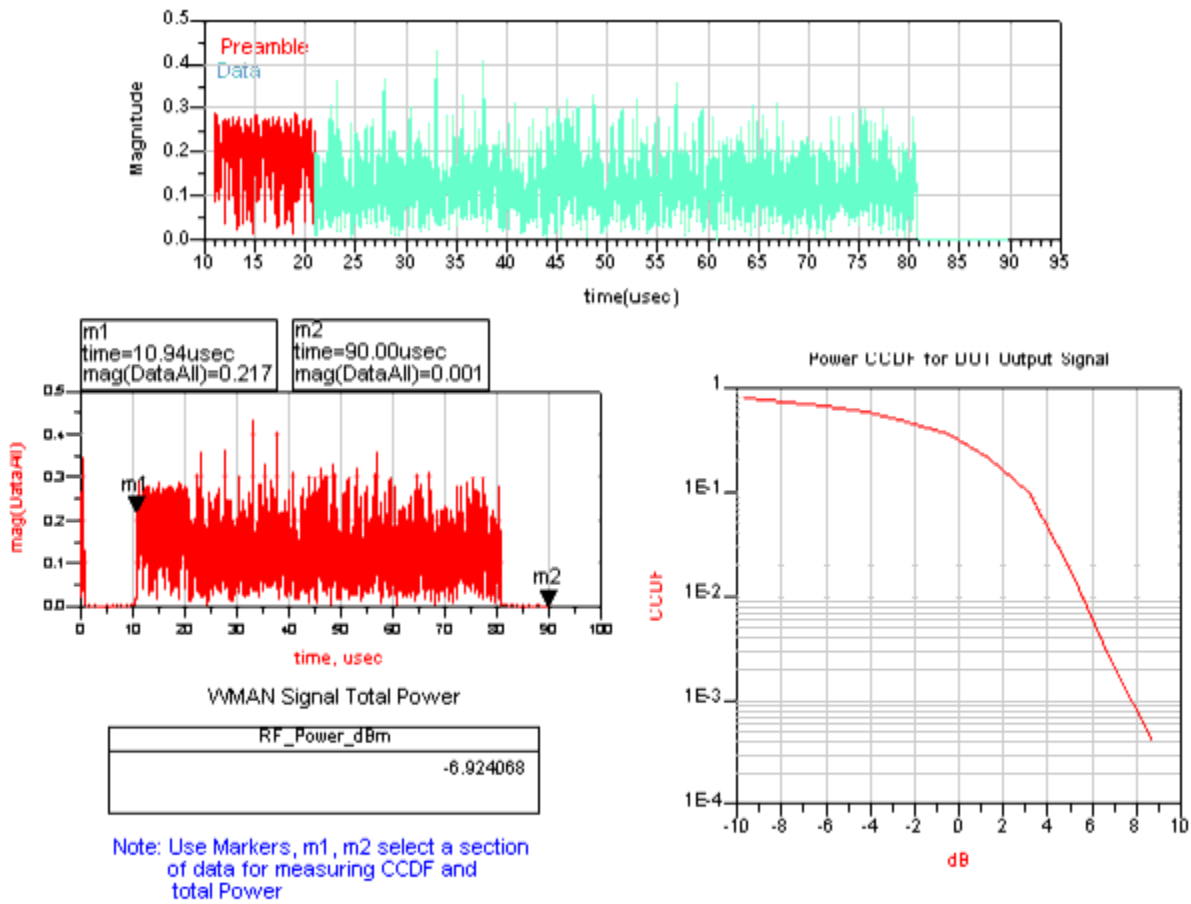

Note: Use Markers, m1, m2 select a section of data for measuring CCDF and total Power

WiMax OFDM DL Signal Source Parameters

RateID	RF_FSource/1MHz	Source_Power_dBm	RF_Bandwidth/1MHz	...SymbolTime/1usec	Frame time/1msec
3.000	2400.000	-20.000	28.000	10.000	0.090

WiMax OFDM UL Measurement shows the spectrum as displayed in a Data Display window. Test signal parameters including source carrier, signal bandwidth, signal power are listed. The spectrum measured matches the specifications: carrier is 2.4 GHz and bandwidth is 28 MHz.

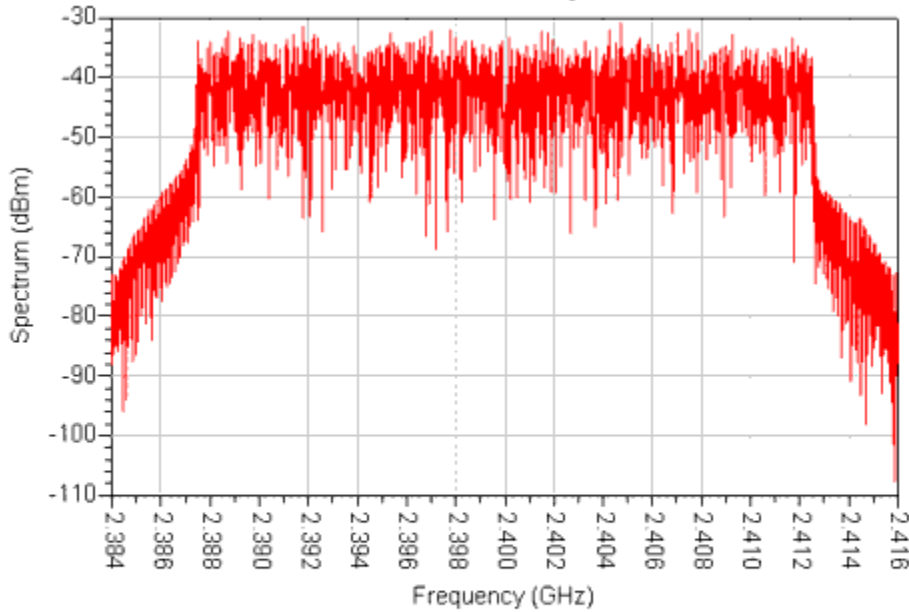

WiMax OFDM UL Signal Source Parameters

RateID	RF_FSource/1MHz	RF_Power_dBm	RF_Bandwidth/1MHz	SymbolTime/1usec	FrameTime/1msec
3.000	2400.000	-6.924	28.000	10.000	0.090

WiMax OFDM UL Measurement

RCE (EVM) measurements are very important for WiMax system test. WiMax OFDM UL Signal EVM Measurements shows the results from the Data Display window. The IEEE 802.16-2004 specification on the RCE is listed. The RCE test result is reported with respect to the corresponding standard value. (Failed or Passed are reported based on the comparison.) The table reports different types of EVM values.

Burst Type	BPSK-1/2	QPSK-1/2	QPSK-3/4	16_QAM-1/2	16_QAM-3/4	64-QAM-2/3	64-QAM-3/4
RCE (dB)	-13.0	-16.0	-18.5	-21.5	-25.0	-28.5	-31.0

RCE Standard in dB

-21.500

Test result for RCE in dB

-43.892

Test is Passed

RCE (%), Pick RCE, Pilot RCE and Frequency Error (Hz)

Index	RCErms_percent	RCEpk_percent	PilotRCE_dB	FrequencyError_Hz
0	0.639	1.905	-43.376	3568.789

Limitations

The WiMax connected solutions project has the following limitations:

- WiMax OFDM FDD is based on IEEE 802.16-2004. WiMax OFDMA features are not included.
- Transmission testing is provided; receiver testing is not provided.
- The DUT must be an RF component with RF signals for both input and output.

References

1. IEEE Standard for Metropolitan Area Networks IEEE P802.16-2004, Oct, 2004.