



**Agilent Technologies**

ADS 2008  
January 2008  
Bluetooth DesignGuide

# Advanced Design System 2008

© Agilent Technologies, Inc. 2000-2008

395 Page Mill Road, Palo Alto, CA 94304 U.S.A.

No part of this manual may be reproduced in any form or by any means (including electronic storage and retrieval or translation into a foreign language) without prior agreement and written consent from Agilent Technologies, Inc. as governed by United States and international copyright laws.

## Acknowledgments

Mentor Graphics is a trademark of Mentor Graphics Corporation in the U.S. and other countries. Microsoft®, Windows®, MS Windows®, Windows NT®, and MS-DOS® are U.S. registered trademarks of Microsoft Corporation. Pentium® is a U.S. registered trademark of Intel Corporation. PostScript® and Acrobat® are trademarks of Adobe Systems Incorporated. UNIX® is a registered trademark of the Open Group. Java™ is a U.S. trademark of Sun Microsystems, Inc. SystemC® is a registered trademark of Open SystemC Initiative, Inc. in the United States and other countries and is used with permission. MATLAB® is a U.S. registered trademark of The Math Works, Inc.. HiSIM2 source code, and all copyrights, trade secrets or other intellectual property rights in and to the source code in its entirety, is owned by Hiroshima University and STARC.

**Errata** The ADS product may contain references to "HP" or "HPEESOF" such as in file names and directory names. The business entity formerly known as "HP EEsof" is now part of Agilent Technologies and is known as "Agilent EEsof". To avoid broken functionality and to maintain backward compatibility for our customers, we did not change all the names and labels that contain "HP" or "HPEESOF" references.

**Warranty** The material contained in this document is provided "as is", and is subject to being changed, without notice, in future editions. Further, to the maximum extent permitted by applicable law, Agilent disclaims all warranties, either express or implied, with regard to this manual and any information contained herein, including but not limited to the implied warranties of merchantability and fitness for a particular purpose. Agilent shall not be liable for errors or for incidental or consequential damages in connection with the furnishing, use, or performance of this document or of any information contained herein. Should Agilent and the user have a separate written agreement with warranty terms covering the material in this document that conflict with these terms, the warranty terms in the separate agreement shall control.

**Technology Licenses** The hardware and/or software described in this document are furnished under a license and may be used or copied only in accordance with the terms of such license. Portions of this product include the SystemC software licensed under Open Source terms, which are available for download at <http://systemc.org/>. This software is redistributed by Agilent. The Contributors of the SystemC software provide this software "as is" and offer no warranty of any kind, express or implied, including without limitation warranties or conditions or title and non-infringement, and implied warranties or conditions merchantability and fitness for a particular purpose. Contributors shall not be liable for any damages of any kind including without limitation direct, indirect, special, incidental and consequential damages, such as lost profits. Any provisions that differ from this disclaimer are offered by Agilent only.

**Restricted Rights Legend** If software is for use in the performance of a U.S. Government prime contract or subcontract, Software is delivered and licensed as "Commercial computer software" as defined in DFAR 252.227-7014 (June 1995), or as a "commercial item" as defined in FAR 2.101(a) or as "Restricted computer software" as defined in FAR 52.227-19 (June 1987) or any equivalent agency regulation or contract clause. Use, duplication or disclosure of Software is subject to Agilent Technologies' standard commercial license terms, and non-DOD Departments and Agencies of the U.S. Government will receive no greater than Restricted Rights as defined in FAR 52.227-19(c)(1-2) (June 1987). U.S. Government users will receive no greater than Limited Rights as defined in FAR 52.227-14 (June 1987) or DFAR 252.227-7015 (b)(2) (November 1995), as applicable in any technical data.

## Contents

- Bluetooth DesignGuide QuickStart
- - Using DesignGuides
    - Accessing Documentation
    - The Bluetooth DesignGuide Menu
  - Displaying Simulation Data
    - Interactive Simulations
- Bluetooth DesignGuide Reference
- - Developing or Integrating a Bluetooth Solution
  - Basic System Test Benches
    - Ideal Transmit-Receive EYE Diagram (TEST\_EYE.dsn)
    - Transmit Spectrum (TEST\_TX\_SPECTRUM.dsn)
  - VCO/PLL (Phase Locked Loop) Investigations
    - VCO Response to Frequency Step (TEST\_PLL\_TR)
  - Component/Subnetwork Evaluations
    - Channel Filter Impulse Response (TEST\_FILTER\_IMPULSE.dsn)
    - Channel Filter Swept Response (TEST\_FILTER\_COMPLEX.dsn)
    - FM Demodulator Selection (TEST\_LOWIF\_FMDEMOM)
  - Multipath Propagation Test Benches
    - Multipath Impulse Response (TEST\_MULTIPATH\_IMPULSE)
    - BER/Outage w/MPath, Noise, No Chan. Filter (TEST\_MULTIPATH\_BER\_NOFILT)
  - System Compliance Tests
  - Medium Rate Radio 1.0 Improvements Test Benches
    - Ideal Pi/4-DQPSK Modem with EVM and BER (pi4DPQSK\_Modem\_Ideal)
    - Medium Rate 2 Mbps Sensitivity and BER Test Bench (TEST\_MR2\_RECEIVER\_SENSIVITY)
    - Ideal 8-DPSK Modem with EVM and BER (8DPSK\_Modem\_Ideal)
    - Medium Rate 3 Mbps Sensitivity and BER Test Bench (TEST\_MR3\_RECEIVER\_SENSITIVITY)
  - Bluetooth Interference by 802.11 WLAN Signals
    - Bluetooth\_with\_80211b\_Interference
    - Bluetooth\_with\_80211g\_Interference
  - Test Benches and Subnetworks
    - Basic System Test Benches
      - Component/Subnetwork Evaluations
      - VCO/PLL (Phase Locked Loop) Investigations
      - Multipath Propagation Test Benches
      - System Compliance Tests
      - Bluetooth with 802.11 Interference Test Benches
    - Subnetworks

## Bluetooth DesignGuide QuickStart

The Bluetooth DesignGuide QuickStart provides an introduction to the content and use of the Bluetooth DesignGuide. To learn more, refer to [Bluetooth DesignGuide Reference](#).

The Bluetooth DesignGuide application package for the Agilent Advanced Design System (ADS), contains various system test benches and reference designs (e.g., an optimal low-IF receiver) for the RF portion of the Bluetooth physical layer. It allows for the investigation of system performance from simple EYE diagrams, to BER (bit error rate) when impairments such as AWGN, VCO phase noise, multipath, and/or co-channel, adjacent-channel, intermodulation and pulsed-RF interference are present. In many cases, the receivers EYE diagram can be observed in real time during simulation while adjusting the level of the signal or interferer via an interactive slider.

The DesignGuide also addresses some phase-lock-loop (PLL) and voltage-controlled oscillation (VCO) design issues and can help you select the best demodulator for your receiver.

### Using DesignGuides

All DesignGuides can be accessed in the Schematic window using either the cascading menus or dialog boxes. Your preferred method can be configured in the Advanced Design System Main window. Select the DesignGuide menu.

 **Note**  
This document describes access through the cascading menu preference. If you are running the program through the selection dialog box method, the appearance and interface will be slightly different.

The commands in this menu are as follows:

DesignGuide Studio Documentation > Developer Studio Documentation This is only available if you installed the DesignGuide Developer Studio. Selecting this brings up the DesignGuide Developer Studio documentation. You can also access this documentation by selecting Help > Topics and Index > DesignGuides > DesignGuide Developer Studio from any ADS program window.

DesignGuide Developer Studio > Start DesignGuide Studio This is only available if you installed the DesignGuide Developer Studio. Selecting it launches the initial Developer Studio dialog box.

Add DesignGuide brings up a directory browser in which you can add a DesignGuide to your installation. This is primarily used with DesignGuides that are custom-built using Developer Studio.

List/Remove DesignGuide brings up a list of your installed DesignGuides. To remove a Design Guide, select any you wish to uninstall and choose the Remove button.

Preferences brings up a dialog box that allows you to:

- Disable the DesignGuide menu commands (except Preferences) in the Main window. By unchecking this box, the complete DesignGuide menu and all of its commands will be removed in the Schematic and Layout windows.
- Select the interface method you prefer (cascading menus or dialog boxes).

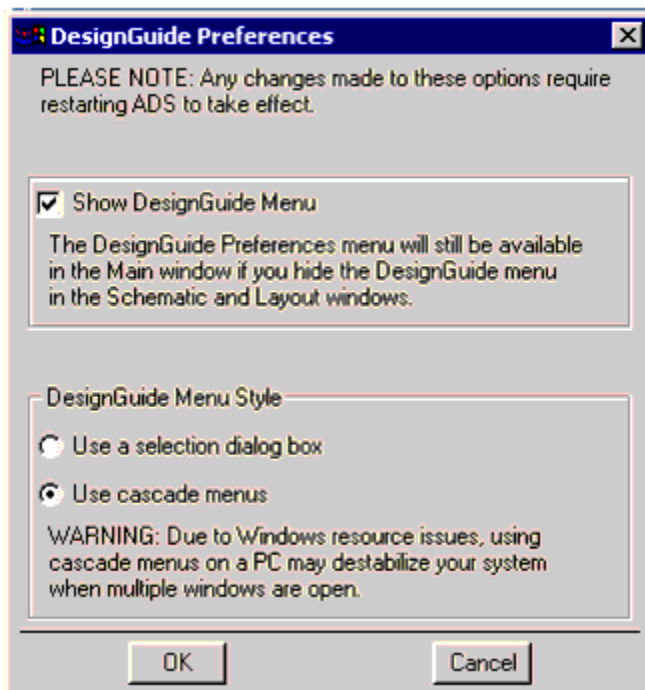

You must close and restart the program for preference changes to take effect.

**Note**  
On PC systems, Windows resource issues can limit the use of cascading menus, opening multiple windows could destabilize your system. In these situations using the dialog box menu is recommended.

## Accessing Documentation

To access the documentation for the DesignGuide, select either of the following:

- DesignGuide > Bluetooth > Bluetooth DesignGuide Documentation (from ADS Schematic window)
- Help > Topics and Index > DesignGuides > Bluetooth (from any ADS program window)

## The Bluetooth DesignGuide Menu

The Bluetooth DesignGuide menu, located in the Schematic or Layout window under DesignGuide, provides convenient access to test benches, subnetworks and data displays. It may be installed as a standalone, or along with other DesignGuides.

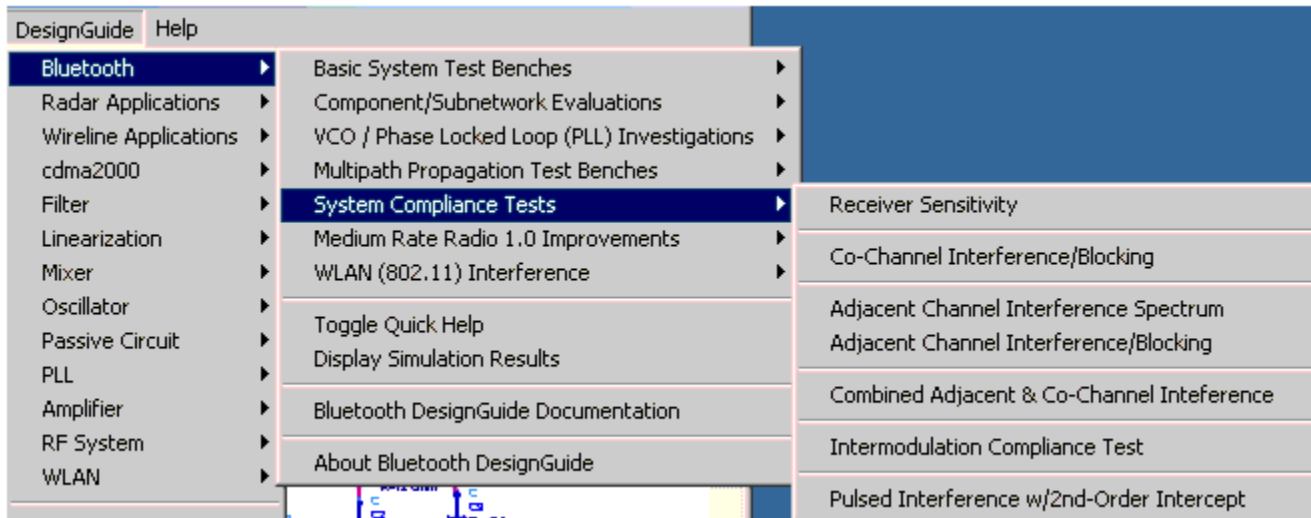

The contents of the Bluetooth DesignGuide menu are divided into several categories:

- Basic System Test Benches. These test benches provide tutorial simulations using the Bluetooth RF segment and allow you to evaluate filtering options for the transmitter.
- Component/Subnetwork Evaluations . These simulations are designed to help you understand and validate many of the built-in subnetworks used in the system test benches.
- VCO/Phase-Locked-Loop (PLL) Investigations. These are simulations of phase-lock-looped topologies address timing and noise issues.
- Multipath Propagation Test Benches. These simulations include multipath models for investigating system performance under non-ideal indoor propagation conditions.
- System Compliance Tests. These system test benches are designed to evaluate sensitivity and blocking performance.
- Medium Rate Radio 1.0 Improvements. These simulations include two modulation formats for proposed enhancements to Bluetooth radios that allow them to operate at higher data rates.
- WLAN (802.11) Interference. An 802.11 signal source is combined with a Bluetooth radio to allow investigations of WLAN interference effects on Bluetooth performance.

For each category, moving the cursor to the right will open a menu displaying the available items. Each selection (except those beginning with Display) will open a top-level test bench schematic and in many cases, a data display. The selections beginning with Display open additional data displays, after the test bench listed above it has opened. You can also access help, BlueTooth DesignGuide documentation and an About... box from this menu.

## Displaying Simulation Data

Some test benches have real-time Tk displays that open each time a simulation is performed. Other test benches automatically open one or more Data Display windows when selected. In several instances, for example a test bench that is capable of BER calculations, additional data displays are available. When a Data Display having the same name as the design has been closed, it can be re-accessed by selecting the Display Simulation Results option listed on the menu, once the test bench has opened.

## Interactive Simulations

Some simulations using Tk displays have interactive sliders that allow a parameter to be adjusted during the simulation. To run a non-interactive simulation where output data is only collected by sinks, (i.e., time-domain or spectrum measurements), all Tk items must be de-activated. The TkPowerControl, TkPowerControl2 or TkPowerControl\_ForRFOffset subnetwork must also be de-activated and bypassed with a wire because it contains an interactive slider.

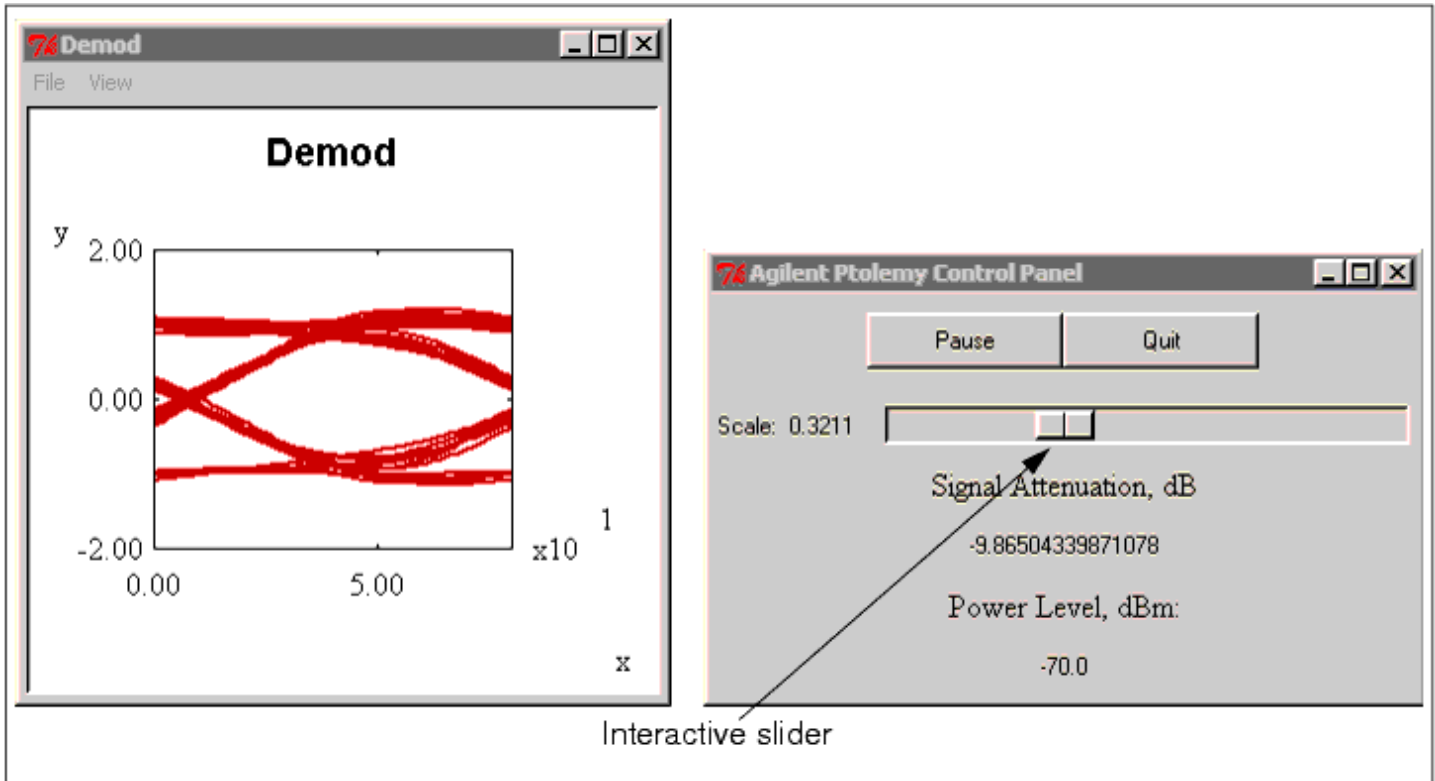

## Bluetooth DesignGuide Reference

This section contains application guidelines for using the test benches provided with the Bluetooth DesignGuide, including:

- Basic System Test Benches
- Component/Subnetwork Evaluations
- VCO/PLL (Phase Locked Loop) Investigations
- Multipath Propagation Test Benches
- System Compliance Tests
- Medium Rate Radio 1.0 Improvements
- WLAN (802.11) Interference

For a complete listing of test benches and subnetworks, refer to the section [Test Benches and Subnetworks](#).

**Note**  
This document assumes a basic understanding of ADS operations. To learn more, refer to the ADS Schematic Capture and Layout manual. For access to the complete set of ADS online documentation, select Help > Topics and Index from any ADS program window.

## Developing or Integrating a Bluetooth Solution

The DesignGuide provides tools for developing or integrating a Bluetooth solution:

- Designing a Bluetooth solution - The DesignGuide supplies a reference receiver design that can be evaluated by comparing the measurements of your RF hardware and simulations of that RF hardware in an ADS model. Other tools target specific components of the Bluetooth physical layer. You should review the Basic System Test Benches, followed by the Component/Subnetwork Evaluations (emphasizing filter selection) before you begin. The VCO/PLL segment is useful if you are designing a synthesized source or need to optimize an existing design for good time-domain performance and phase noise characteristics. Test Benches supporting the newly proposed modulation formats for medium-rate operation are included. The System Compliance Tests focus on determining sensitivity and evaluating performance in the presence of interferers.
- Integrating a Bluetooth solution - For integration into a product, such as another wireless device, handset or any environment with other RF emitters, the DesignGuide provides simulation-based tools for evaluating system performance under various conditions. Before you begin, you should review the Basic System Test Benches, followed by the System Compliance Tests. The Multipath Propagation Test Benches model various indoor propagation conditions allowing you to observe their effect on system performance. The WLAN 802.11 Interference test bench ( requires the WLAN Design Library ) enables you to observe the effect of WLAN 802.11a and 802.11g interference on Bluetooth performance. Selected test benches are described in the following sections. For a complete list of available test benches refer to [Test Benches and Subnetworks](#).

## Basic System Test Benches

The basic system test benches provide an introduction to the Bluetooth RF interface. This section describes some of the main components and subnetworks in the DesignGuide.

Ideal Transmit-Receive EYE Diagram (TEST\_EYE.dsn)

Ideal Transmit-Receive EYE Diagram (TEST\_EYE.dsn)

This simulation is used to observe the EYE diagram created from the combined effects of a transmitter and the complete receiver. The system is built with the most basic components. SHAPED\_DATA produces Gaussian-filtered MSK data according to the Bluetooth specification and an optional Preamble, which consists of the 10101010 sequence, can be included by setting Preamble > 1.

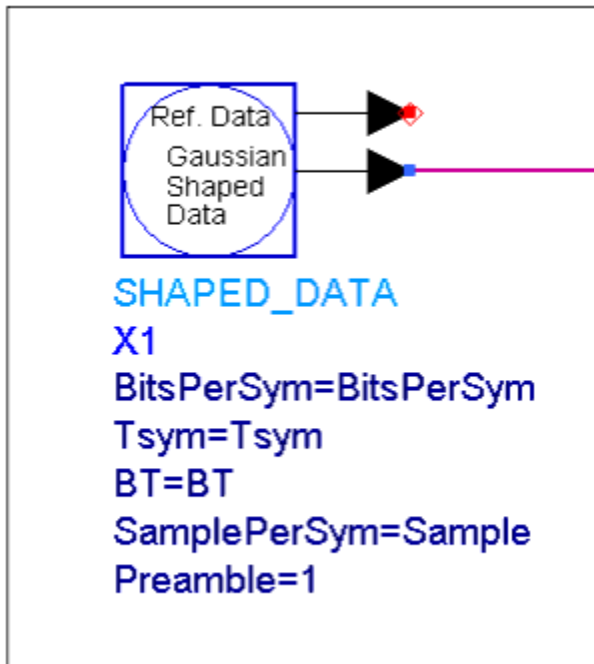

The SHAPED\_DATA output is input into an ideal ADS FM modulator component. The TkPowerControl allows the signal level to be adjusted using an interactive slider. AWGN\_CHANNEL adds thermal noise equal to -174 dBm/Hz to the signal.

**Note**  
SHAPED\_DATA, TkPowerControl and AWGN\_CHANNEL are all subnetworks created for the Bluetooth DesignGuide. AddNDensity, a component available in recent releases of ADS, provides similar functionality to AWGN\_CHANNEL but also allows the noise spectral density, in dBm/Hz, to be specified.

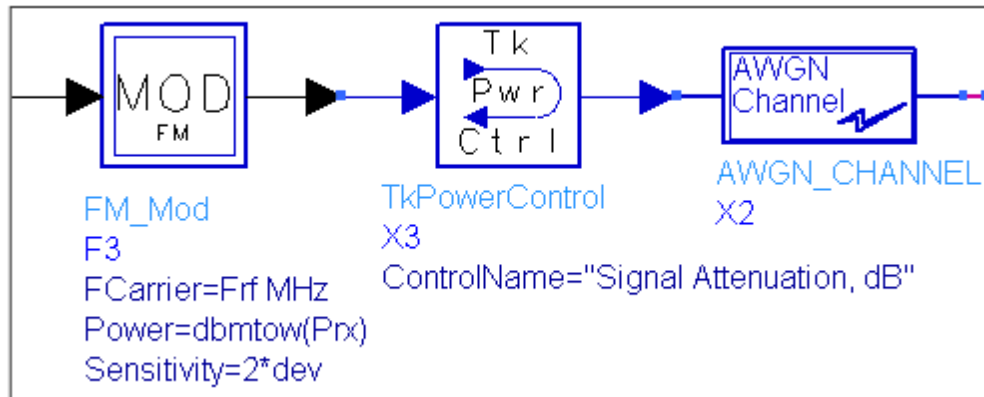

The signal is bandpass-filtered and ideally demodulated.

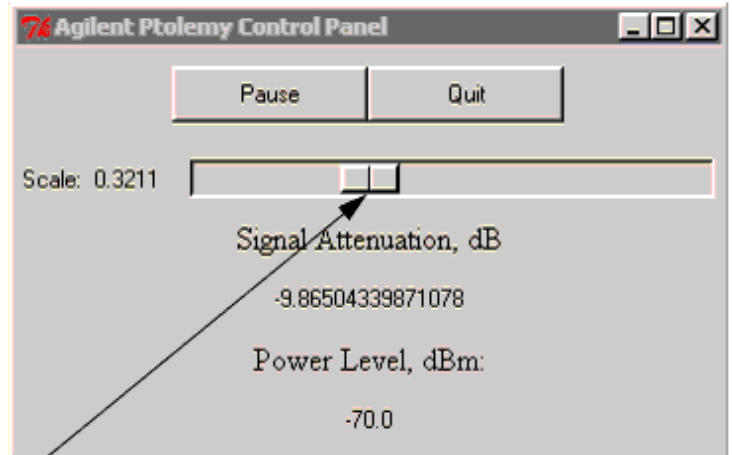
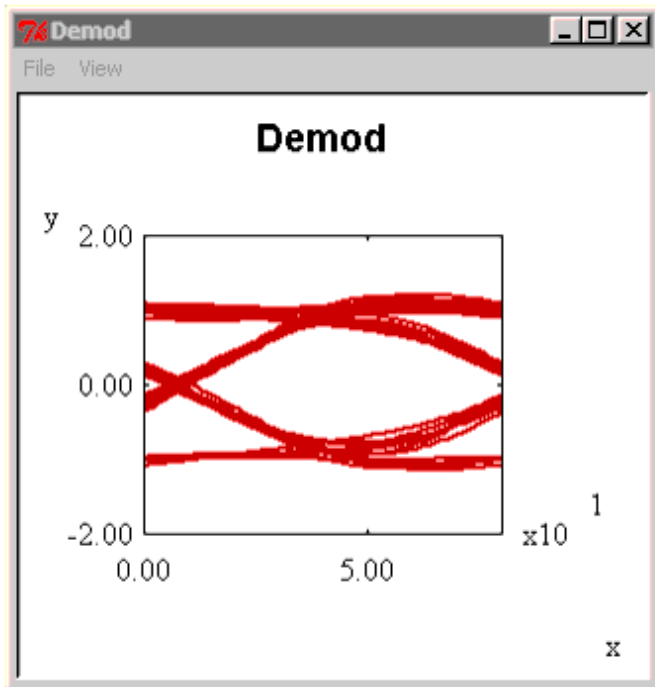
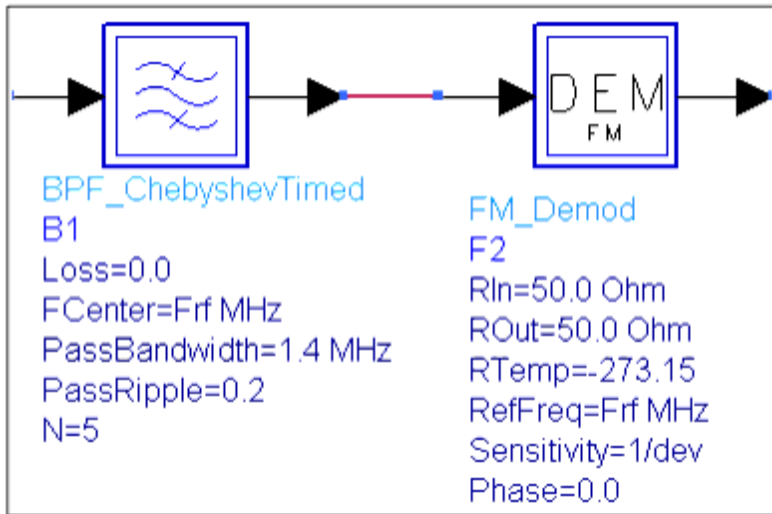

Interactive slider

After scaling and conversion to floating-point, the EYE diagram is displayed on a TkPlot.

Transmit Spectrum (TEST\_TX\_SPECTRUM.dsn)

This test bench illustrates some of the filtering options for the Bluetooth transmitter. When the 8-bit FIR filter is used, images of the spectrum are seen at intervals related to the sampling rate. Note that because these images are below the phase noise sidebands they are adequately filtered out.

Additional analysis of the FIR filter can be found by selecting Component/Subnetwork Evaluations > Transmit Filter (Gaussian FIR) .

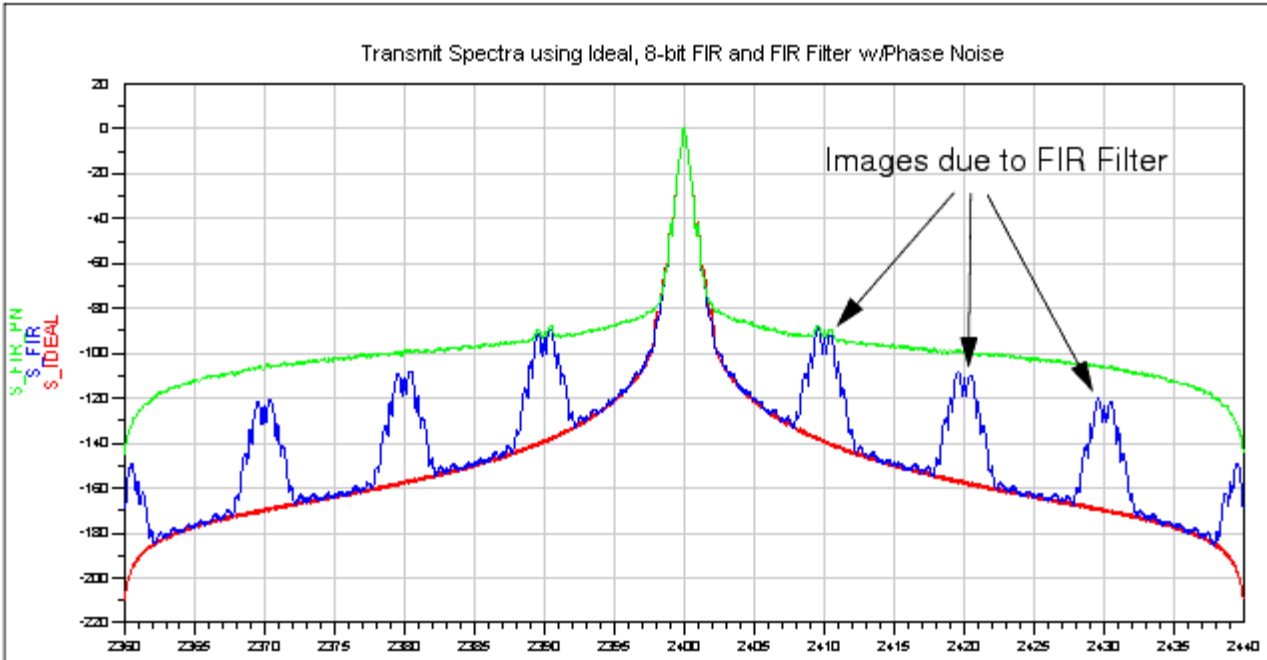

## VCO/PLL (Phase Locked Loop) Investigations

These test benches provide a set of tools that assist in the design and optimization of signal sources for a Bluetooth implementation. These basic tools address key performance requirements. For the full PLL design flow, the ADS PLL DesignGuide is available.

### VCO Response to Frequency Step (TEST\_PLL\_TR)

This test bench demonstrates the Bluetooth Fractional-N Synthesizer transient response to an 80-MHz step. The VCO frequency is 2.4 GHz and the reference frequency is 1 MHz. The output frequency is  $F_{vco}+N$  or 2.48 GHz. The loop bandwidth,  $f_n$ , is 5 kHz.

This design, is simulated under the Transient controller using the VCO\_DivideByN and PhaseFreqDet components. The PFD output is coupled to the RC loop filter using the voltage controlled current source (VCCS). The source frequency must settle to within +/- 20PPM in 200  $\mu$ . To understand how to optimize the loop filter, select VCO Parameter Optimization.

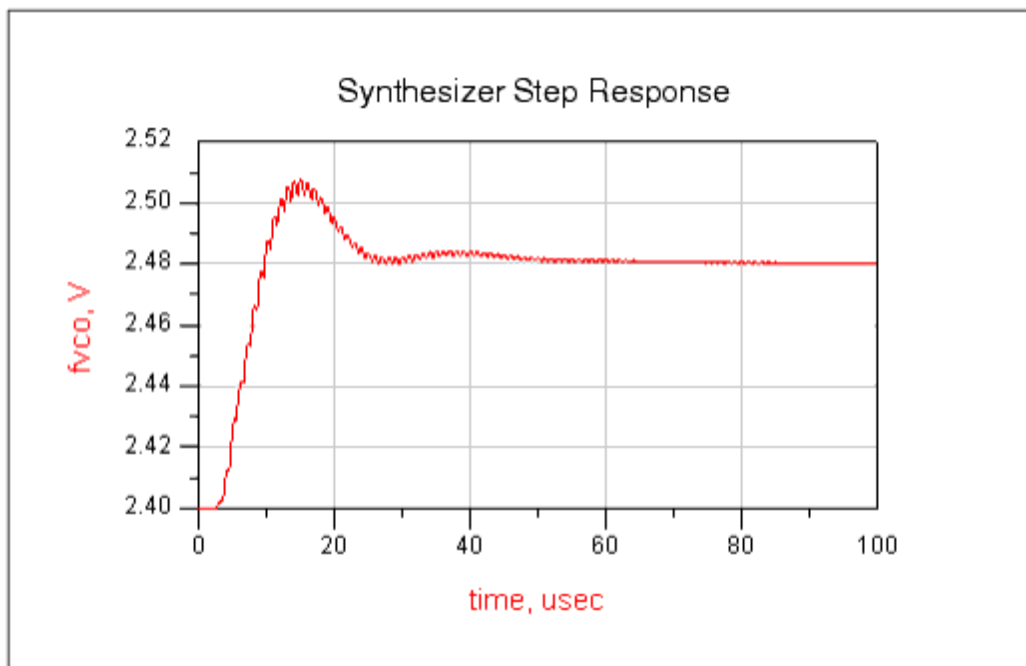
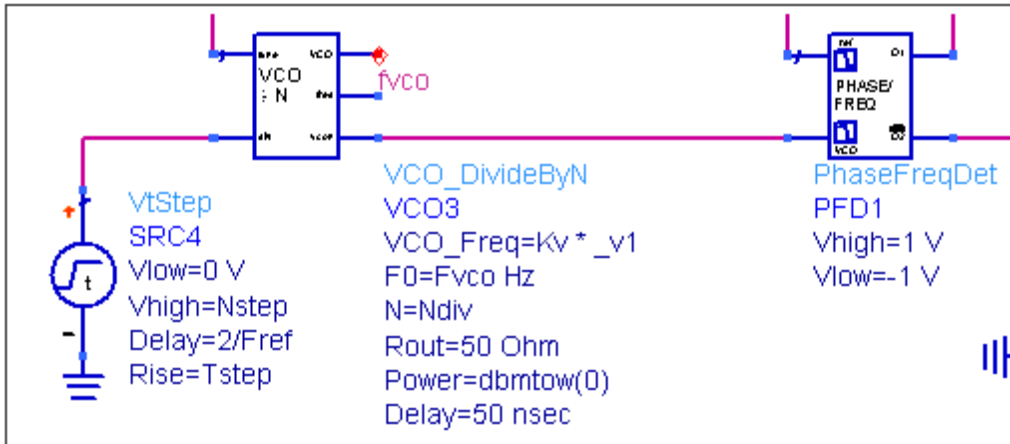

## Component/Subnetwork Evaluations

Following are details on designs demonstrating component/subnetwork evaluations.

### Channel Filter Impulse Response (TEST\_FILTER\_IMPULSE.dsn)

This test bench evaluates the impulse response of the Bessel filter used for pulse shaping in the Bluetooth receiver. ADS has two simulation modes: Analog/RF and DSP. This test bench compares the impulse responses of the circuit (A/RF) and timed (DSP) models, which can be very similar. The A/RF model has an advantage in that its group delay

at the edge of the passband can be controlled. Using it in a DSP design requires Transient cosimulation, which can be slower.

### Channel Filter Swept Response (TEST\_FILTER\_COMPLEX.dsn)

This test bench sweeps the complex receiver filter model used in the DesignGuide (FILTER\_CHEB\_COMPLEX). Open Data Display TEST\_FILTER\_COMPLEX. Note that QAM\_Demod is set for a gain imbalance of 0.5 dB and a phase imbalance of 3 degrees. The data display compares the swept RF response to the balanced condition.

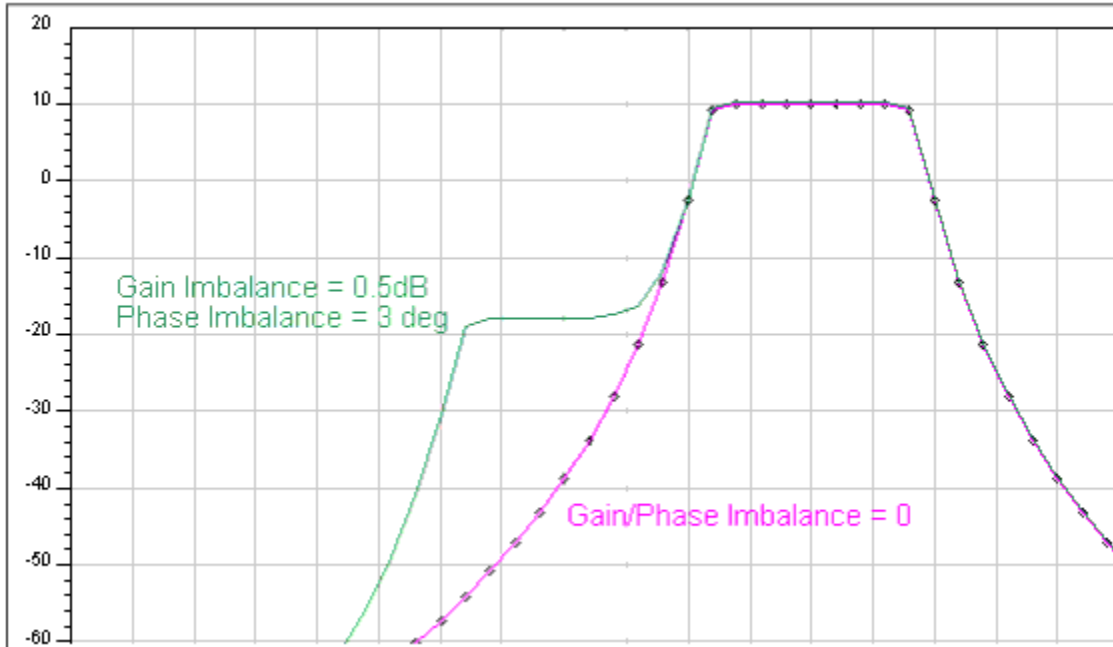

### FM Demodulator Selection (TEST\_LOWIF\_FMDEMODO)

An EYE diagram display allows observation of the relative performance of various demodulators. Due to the different output levels and the amount of residual DC for each demodulator, select View > View ALL on the Demod\_TEST TkPlot to see the EYE diagram.

Demodulator selection is important when designing a Bluetooth solution because receiver performance is often dependent upon the demodulator's performance. The DesignGuide provides a choice of several demodulators.

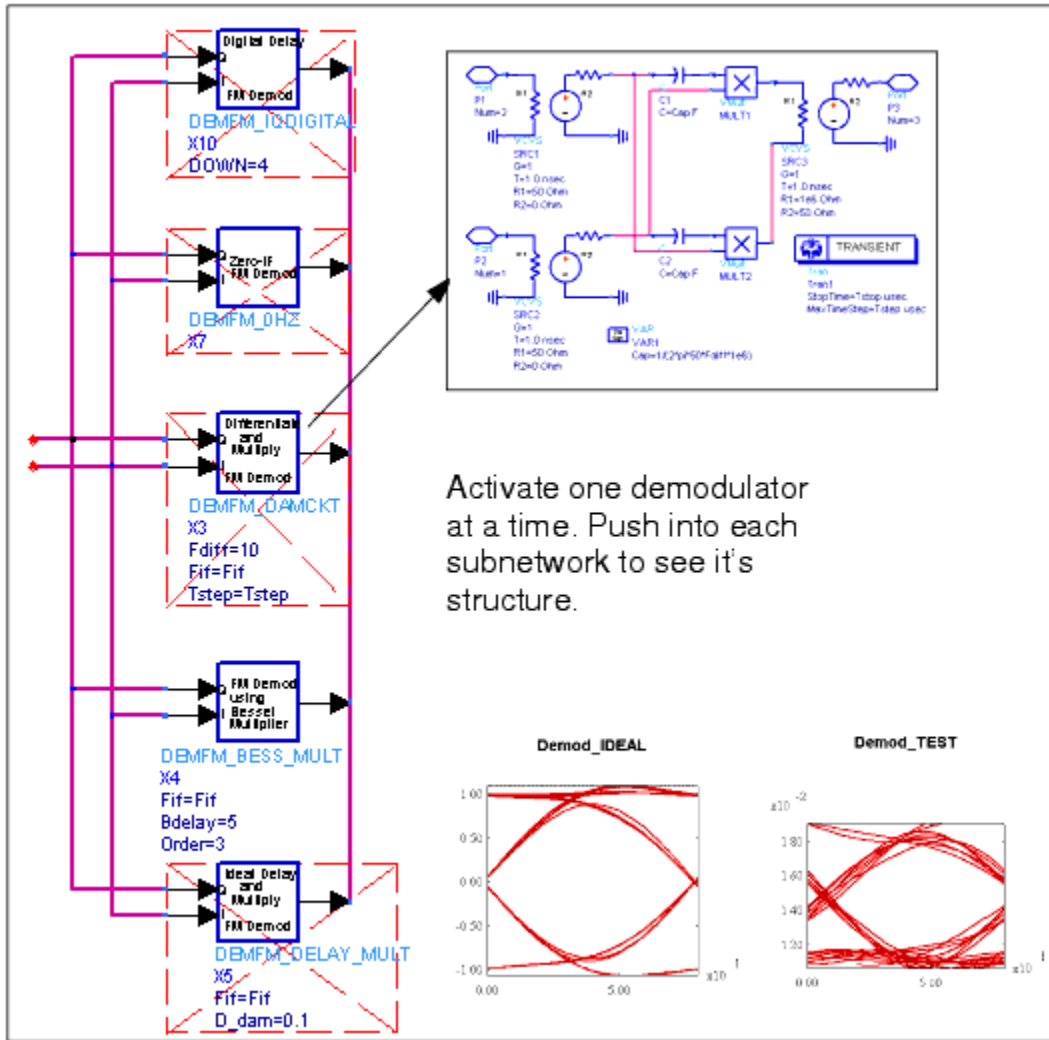

For descriptions of each demodulator refer to [Subnetworks](#). In the proceeding illustration DEMFM\_BESS\_MULT, a delay and multiply polyphase FM demodulator, is notable for its exceptional performance when compared to other demodulators. An additional test bench, available under FM Demod Selection w/Channel Filter uses a single complex Chebyshev channel filter in the receiver, instead of the highpass/Chebyshev/limiter/Bessel signal path used in TEST\_LOWIF\_FMDMOD. Using this test bench puts additional requirements on the demodulator in exchange for a simpler signal path.

## Multipath Propagation Test Benches

Following are summaries of test benches used for multipath propagation.

### Multipath Impulse Response (TEST\_MULTIPATH\_IMPULSE)

This test bench evaluates the MULTIPATH\_EXPONENTIAL model using an impulse input. The delay spread profile is shown in the associated data display. Due to the use of a moving average over 512 symbols, the data display will require several minutes to open (approximately 2 minutes for a Pentium III at 650 MHz under Windows NT). Select Display Impulse Response after the schematic is displayed to show the data display window.

**Note**  
The multipath subnetwork requires a large memory space due to its complexity. Performance will be reduced on systems having less than 256 MB of RAM.

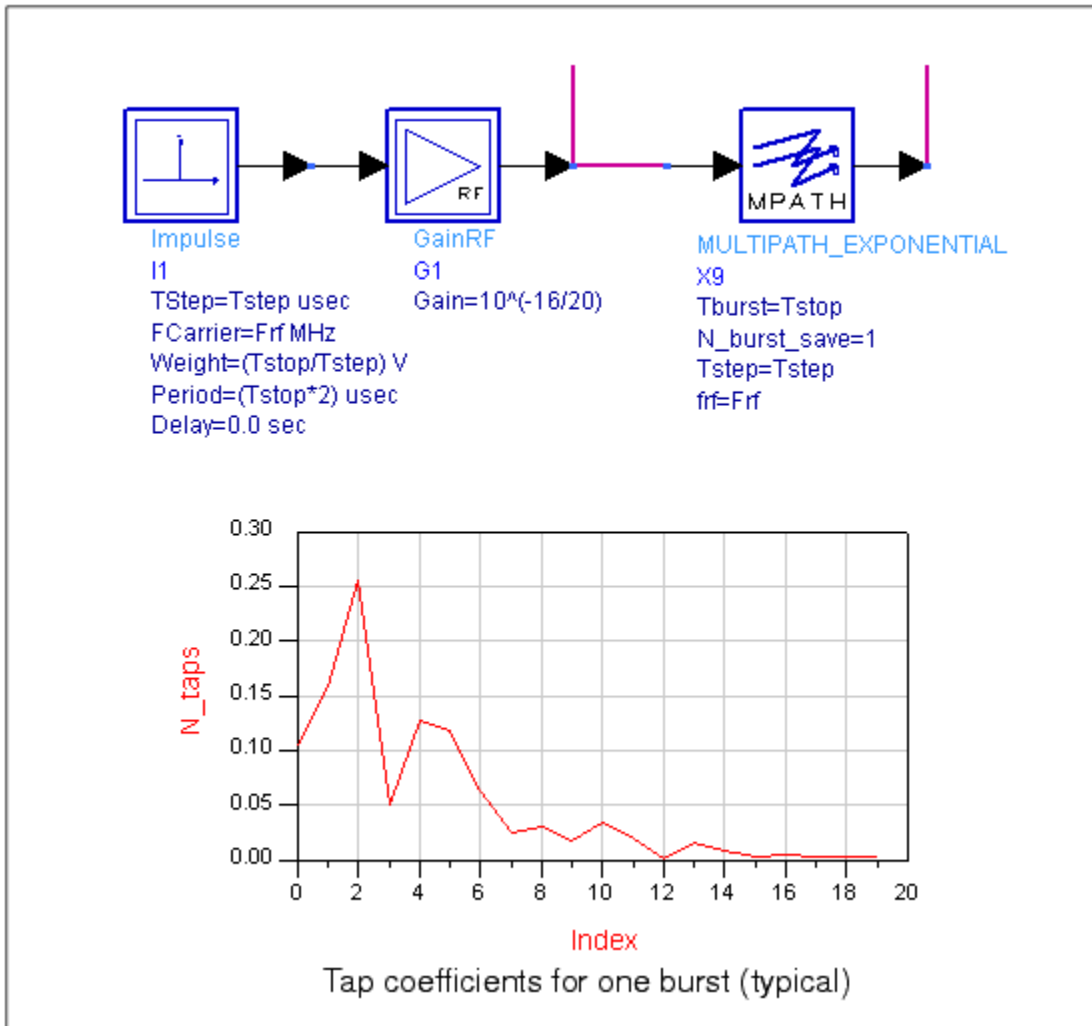

The MULTIPATH\_EXPONENTIAL model implements an exponential power decay multi-path channel model that is widely used for indoor propagation. The mean excess delay and the tap delay can be specified in microseconds. Each tap coefficient has a Rayleigh power distribution, and a uniform phase distribution. For a specified value of time Tburst, the channel snapshot is kept fixed. For the next Tburst duration, a new channel snapshot is taken. The tap coefficients for each snapshot, the corresponding values of the RMS delay spread and the mean excess delay are all available. TK plots for these measurements can also be enabled.

The tap coefficients are calculated by:

$$r = \exp(-\text{Delay\_Tap}/\text{Mean\_Delay})$$

$$a_0 = 1/\text{Mean\_Delay}, a_1 = r*a_0, a_2 = r*a_1, \dots, a_n = r*a_{(n-1)}$$

BER/Outage w/MPath, Noise, No Chan. Filter (TEST\_MULTIPATH\_BER\_NOFILT)

This test bench calculates the BER without a channel filter, but includes multipath. It will usually exhibit ideal BER because the C/N is large (the transmit power is 0 dBm and no noise is included). The mean delay is larger than for the other multipath test benches, being set to 0.2  $\mu$ , and the tap delay is 0.05  $\mu$ . To observe channel outage, activate SweepSeed to vary the random seed value used by the Data Flow simulator. A channel with BER > 0.1% is considered to have caused a failed burst transmission. The simulation time is approximately 120 seconds (with PARAMETER SWEEP deactivated), for 250 bits using a Pentium III at 650 MHz under Windows NT with 256 MB RAM.

**Note**  
Simulation time will increase significantly if less than 256 MB of RAM are available.

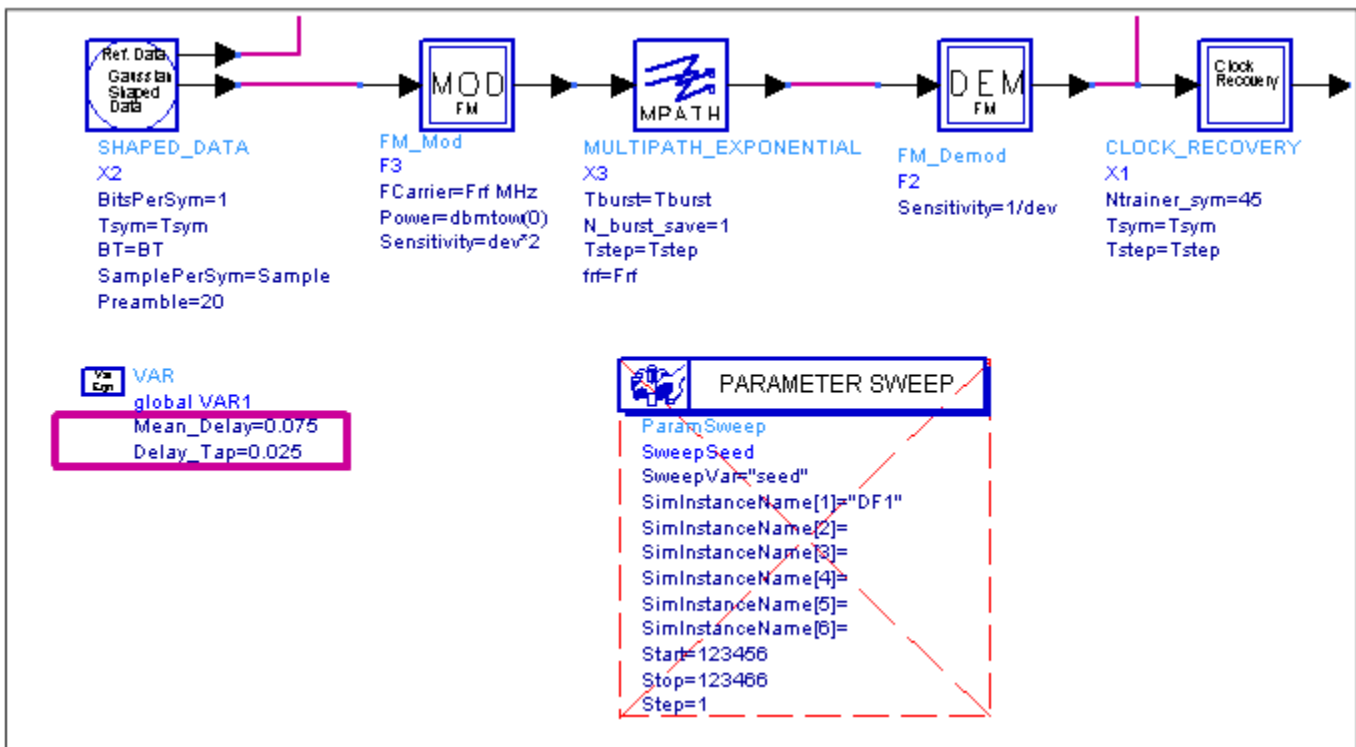

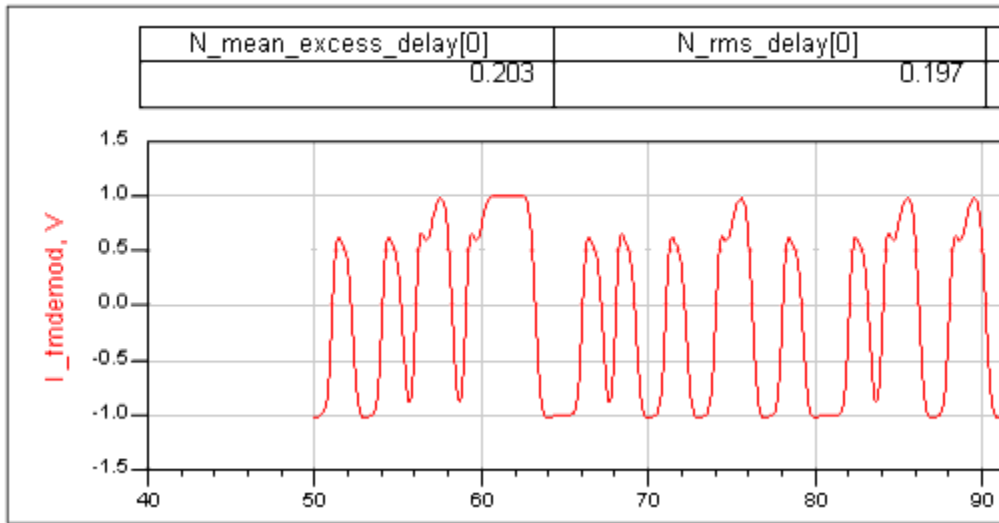

The preceding figure shows a portion of the output display for multipath (0.2  $\mu$  delay setting) with no channel filter at the output of the ideal FM demodulator. The Clock Recovery action accepts this distorted input and re-syncs the data. You may wish to vary this test bench by substituting other non-ideal demodulators, such as the subnetworks provided with the DesignGuide and observe their performance under multipath conditions.

## System Compliance Tests

Interferer Type	Interferer level P[dBc]	Wanted signal level, P[dB]>reference sensitivity
Co-Channel interference, C/I	11 dB	10
Adjacent (1 MHz) interference, C/I	0 dB	10

Each test bench sets up a starting condition according to [Interference Performance Requirements](#). Conditions other than these can also easily be specified; for example, the adjacent interferer offset can be set to 1, 2, 3 or more MHz away from the wanted signal. An interactive slider provides for attenuating the interfering signal while observing the EYE diagram. For BER tests, the interactive slider is not used, and the appropriate components are de-activated as described on the test bench.

The system compliance tests available are:

- Combined Co-Channel/Adjacent Channel test
- Intermodulation test
- Pulsed Interferer with 2nd-order Intercept (IP2) Test Bench.

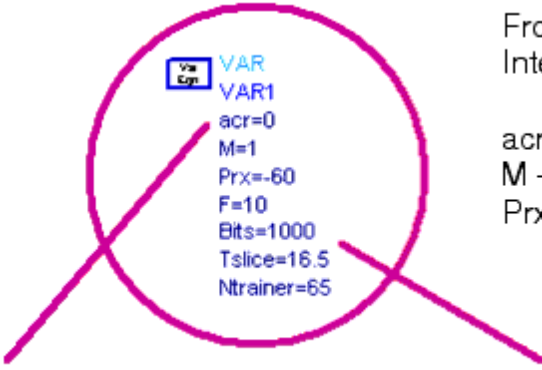

```

VAR
VAR1
acr=0
M=1
Prx=-60
F=10
Bits=1000
Tslice=16.5
Ntrainer=65
                    
```

From the Adjacent Channel Interference/Blocking Test Bench:

acr – sets the interferer's relative power  
M – sets the frequency offset in MHz  
Prx – sets the wanted signal's power

**Test EYE - Adjacent Interferer**

File View

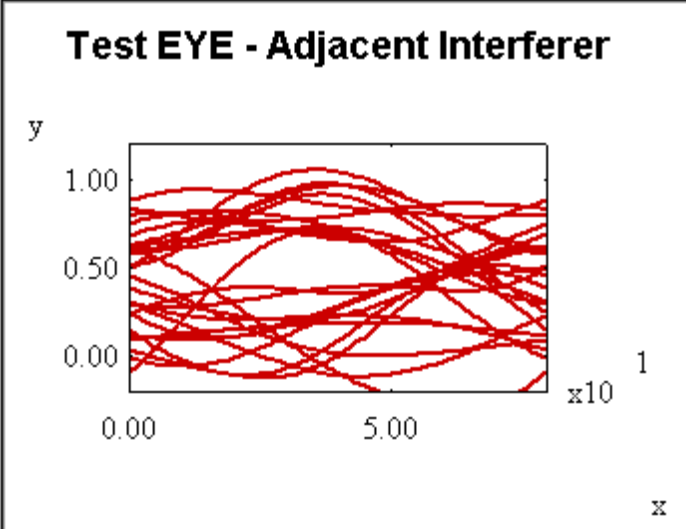

**Agilent Ptolemy Control Panel**

Pause Quit

Power Level, dBm:  
-60.0

Interferer Relative Power, dBm:  
0.0

Interferer Separation, MHz  
1.0

Scale: 1.0

ADJ Interferer

The preceding graphics show the EYE diagram and Control Panel for the Adjacent Channel Interference Test Bench. Moving the slider to the left attenuates the interferer level.

## Medium Rate Radio 1.0 Improvements Test Benches

At the time of publication (Version 2.1.1 of this DesignGuide), proposals have been made to support higher data rates within the framework of the Bluetooth 1.0/1.1 Specification. Test benches which simulate the two modulation formats under consideration, Pi/4-DQPSK and 8-DPSK, for 2 and 3 Mbps respectively, are included.

**Note**  
Parameters have been set using the best information available but you are encouraged to obtain the latest Specifications from the Bluetooth SIG.

## Ideal Pi/4-DQPSK Modem with EVM and BER (pi4DPQSK\_Modem\_Ideal)

This test bench models an ideal 2 Mbps radio with a variable-length GFSK preamble. Measurements of the modulated signal, such as spectrum mask and EVM are available. In addition, BER may be determined using a variety of methods. The default configuration will produce the dataset for the display pi4DQPSK\_Modem\_Ideal\_Mask.dds, which includes Spectrum Mask, Trajectory, Input/Output Data, BER (short Monte Carlo estimate), RMS EVM and Peak EVM.

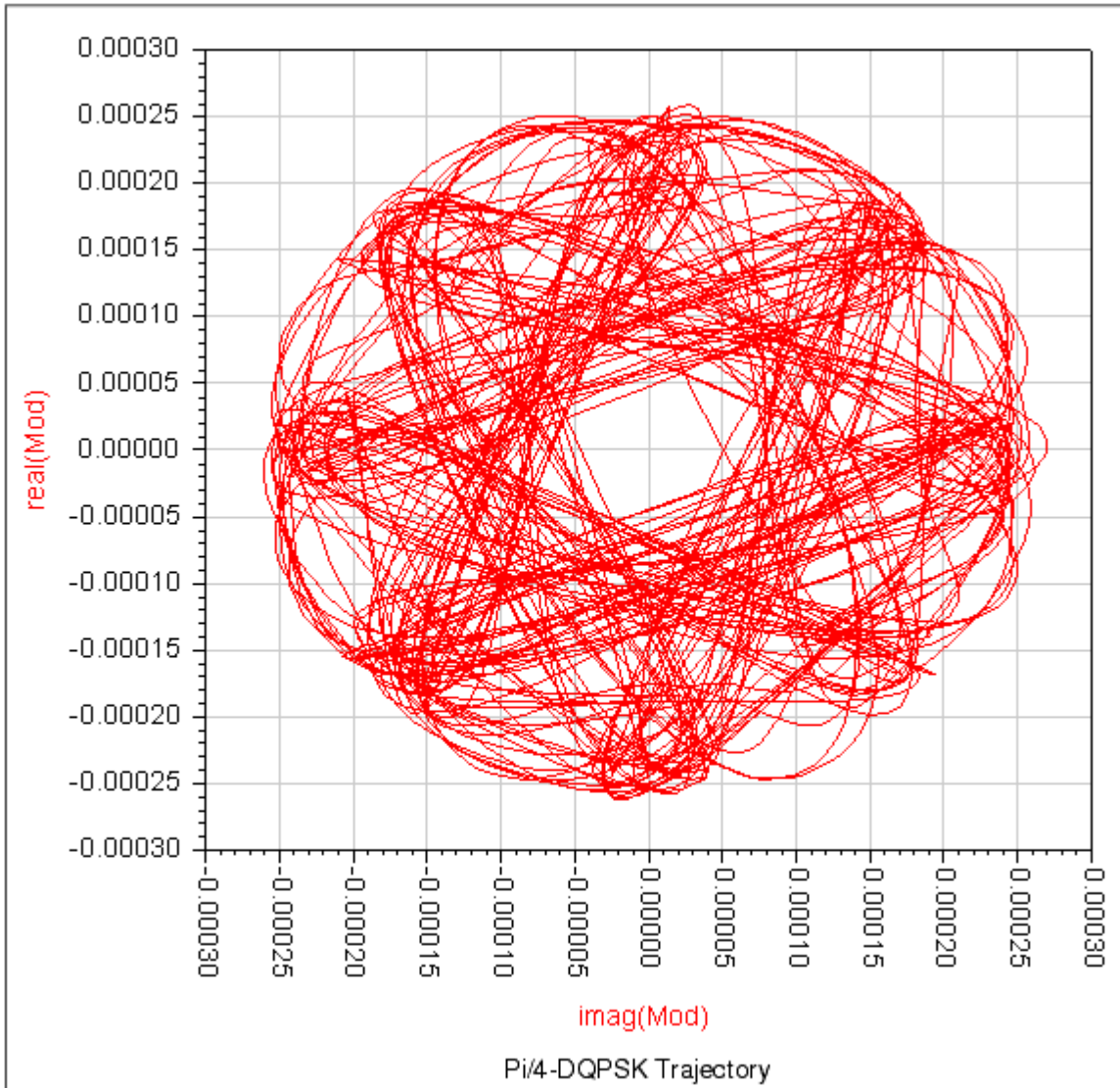

Some modulation formats, including Pi/4-DQPSK, are compatible with BER estimation using sampling reduction methods such as Importance Sampling. ADS provides this via the berIS component. Such methods reduce the BER simulation time by several orders of magnitude. However, certain guidelines must be followed. In particular, noise sources internal to the simulation should be set to 0, except for AddNDensity, which should be set to -174 dBm/Hz. The Receiver noise figure, determined by the variable F, should be set to 0. The berIS component will internally sweep  $E_s/N_0$  during the simulation, providing the noise model. The simulation runs until the Relative Variance, EstVar, is met.

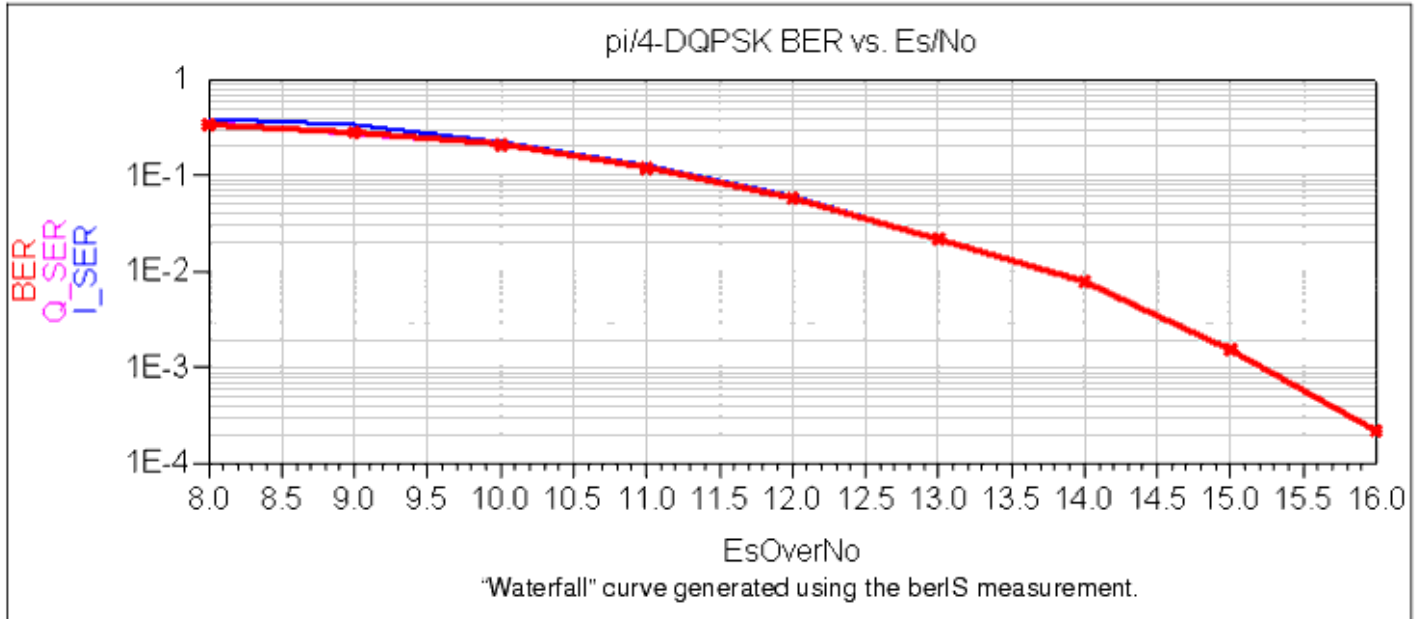

When using berIS the symbol error rate (SER) for the I and Q symbols are found individually. They are combined during post-processing using the following Data Display expressions. (Refer to the berIS documentation for more information.)

```
Eqn BitsPerSym=2
Eqn PEI=I_SER/BitsPerSym
Eqn PEQ=Q_SER/BitsPerSym
Eqn BER=PEI[::] + PEQ[::] - (PEI[::]*PEQ[::])
```

Medium Rate 2 Mbps Sensitivity and BER Test Bench (TEST\_MR2\_RECEIVER\_SENSIVITY)

This test bench implements the 2 Mbps mode using interactive control to view EYE diagrams, output data and a real-time BER estimate as the received power is varied via a slider. The BER\_TK subnetwork updates every 500 samples; the first value will be at 500-Tsave, (e.g., for Tsave =100), the display will update at 400, 900, 1400, et cetera. It may also be configured for BER using Importance Sampling. The transmitter and receiver are inside subnetworks, rather than at the top level design. A berMC measurement is also provided, for determining BER vs. a swept parameter other than Es/No, such as Prx.

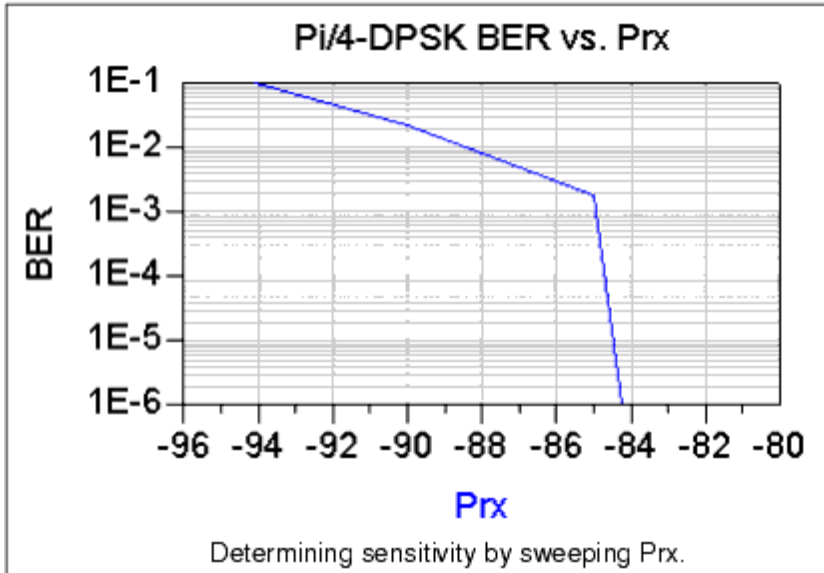

#### Ideal 8-DPSK Modem with EVM and BER (8DPSK\_Modem\_Ideal)

For 3 Mbps operation, 8-state Differential Phase Shift Keying (8-DPSK) has been proposed. This test bench provides an ideal modem with measurements for Spectrum Mask, EVM and BER. The radio has a variable-length GFSK preamble, implemented using an RF switch component to disconnect the GFSK source and connect the 8-DPSK source when the preamble is ended.

The 8-DPSK modem can be described as follows: Pseudo-random data in binary NRZ (non return to zero format, +/-1V) from the timed Data component are differentially encoded using the BinaryCoder component. The SymbolConverter maps the data to 8-level Pulse Amplitude Modulated (PAM) symbols; there are 3 bits per symbol. Before the symbols can be phase modulated onto a carrier, scaling and offset must be applied. The phase modulator has a sensitivity of 360 degrees/volt. To properly map the 8 symbol levels to the correct phase-keying states, the input should be between -0.375 V and 0.500 V. The GainRF component scales the NRZ data by  $2/0.875 = 0.4375$ . The DCShift offsets the signal by  $0.5/8 = +0.0625$  V.

Root raised-cosine pulse shaping has also been proposed. In the next two illustrations 8-DPSK IQ trajectory is first shown without any filtering in the transmitter and then with filtering applied. For practical rectangular pulse modems, equalization of  $f/\sin(f)$  is also applied.

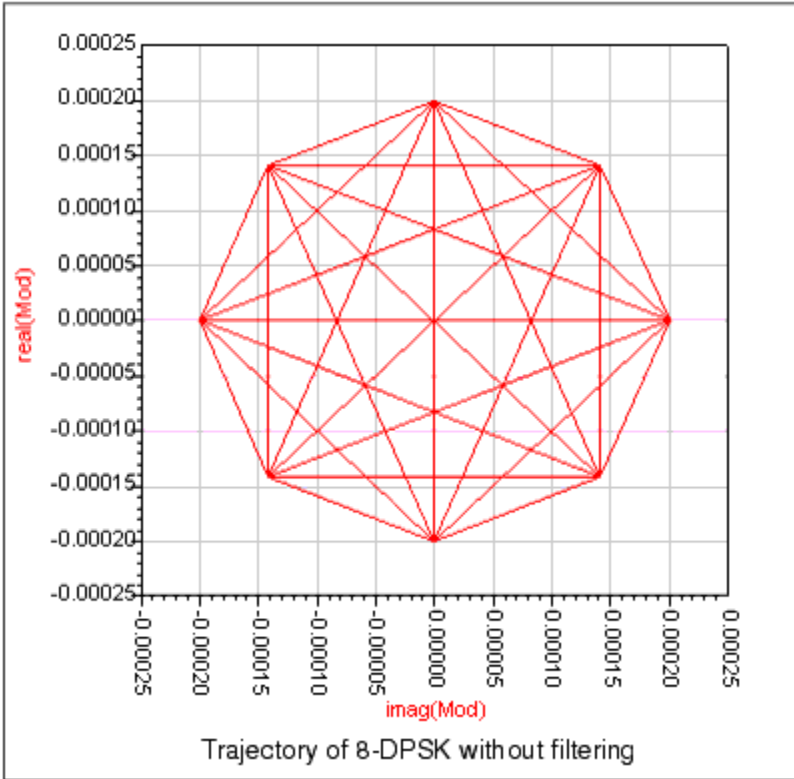

Raised-cosine filtering limits transitions to the unit circle. For a roll-off factor of 0.4 (proposed), the trajectory appears thus:

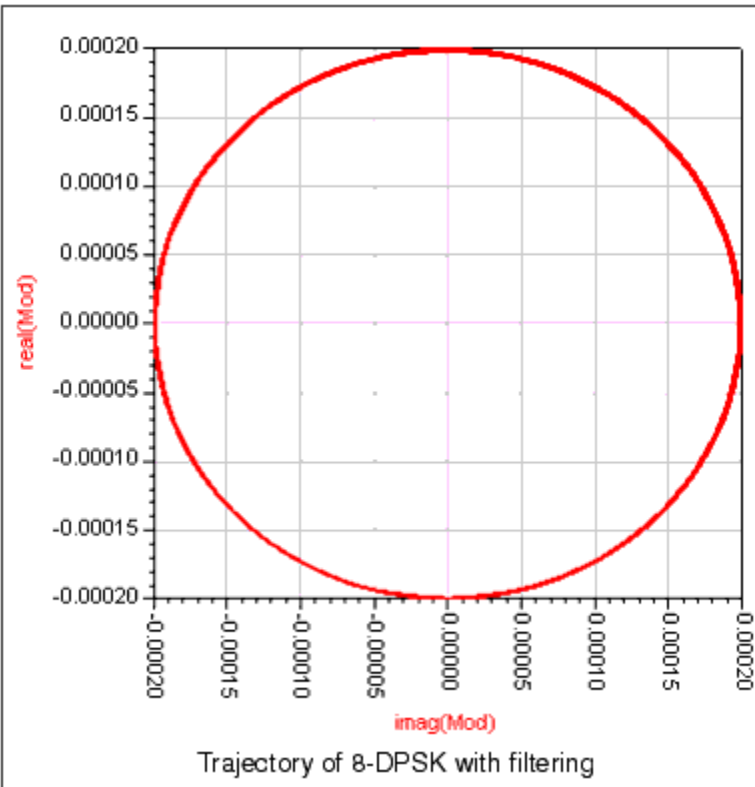

AddNDensity provides the channel noise model. The receiver uses clock recovery and hard decision decoding. The

received signal is split to the clock recovery structure and to the quadrature demodulator. Following ideal demodulation of the I and Q parts of the signal, root raised cosine filters are applied. The clock recovery uses the GFSK preamble (alternating 101010.... pattern) to extract the clock, which is used to clock the I and Q SampleAndHold components. The Quantizer2D forces the sampled points to the nearest points on the 8-PSK constellation. This signal is applied to the PM\_Demod. The PM\_Demod output is inversely scaled and applied to a SymbolConverter set for PAM8 input and NRZ output. The BinaryCoder performs differential decoding to fully recover the output data.

Measurement taps are provided to send input and output data, encoded input and output symbols, spectrum and trajectory data to the dataset. The display 8PSK\_Modem\_Ideal\_Mask shows all of these signals. Of particular interest is the recovered clock signal, on display page 2, and the encoded input and output symbols overlaid.

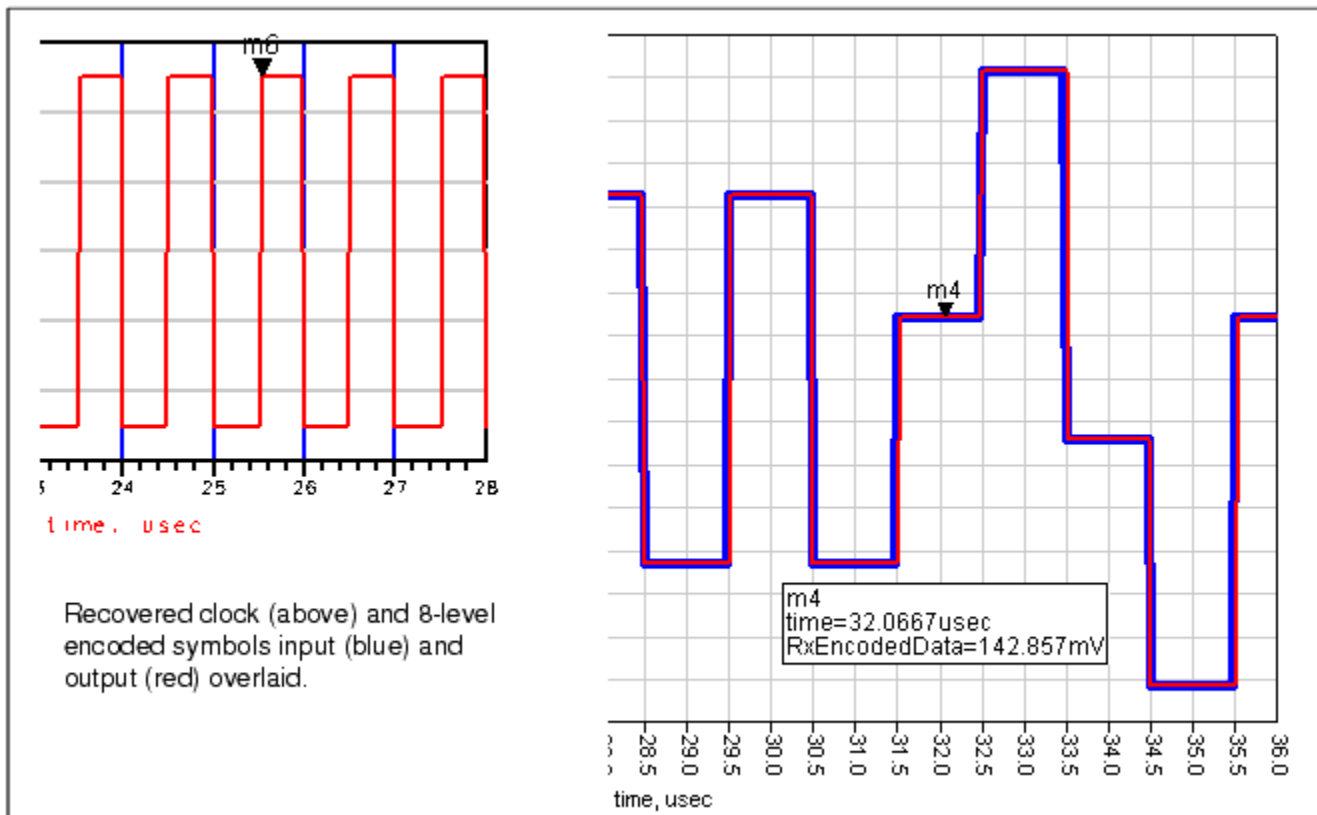

EVM and BER measurements are provided. BER is performed using the berMC component. Sampling reduction methods (such as Importance Sampling ) are not applicable to constant-envelope modulation such as 8-DPSK. The berMC component will now control the simulation until EstRelVariance is achieved. It is not necessary to determine in advance how many samples are required for an accurate BER estimate. This is different from other test benches in the Bluetooth DesignGuide which have a "Numbits" variable to set the BER simulation length as a function of a swept parameter.

Of particular interest is the relation between the filter roll-off factor (variable BT) and error performance. It can be shown that a roll-off of 0.4 is not sufficient for acceptable performance; BT should be 0.60 or larger for best performance.

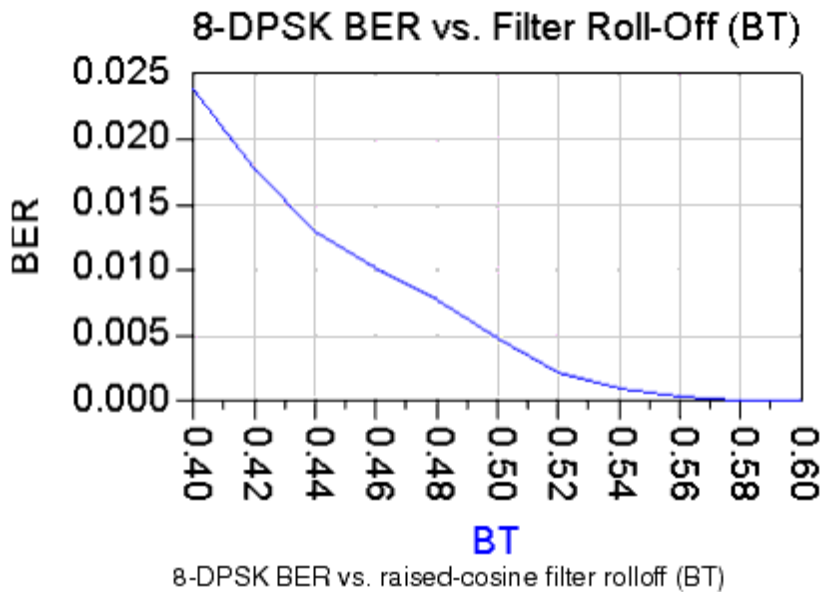

#### Medium Rate 3 Mbps Sensitivity and BER Test Bench (TEST\_MR3\_RECEIVER\_SENSITIVITY)

This test bench implements the 3Mbps mode using interactive control to view EYE diagrams, output data and a real-time BER estimate as the received power is varied via a slider. The BER\_TK subnetwork updates every 500 samples; the first value will be at 500-Tsave, (e.g., for Tsave =100), the display will update at 400, 900, 1400, et cetera. The transmitter and receiver are inside subnetworks, rather than at the top level design. A berMC measurement is also provided, for determining BER vs. a swept parameter such as Prx or Eb/No.

For BER vs. Eb/No, the AddNDensity component is set via an expression to the correct noise density for each sweep point, using:

$$\text{NoiseDensity} = \text{Prx} - 10 * \log(\text{DataRate}) - \text{EbNo}$$

where Prx is the signal power, DataRate is in bits/sec and Eb/No is in dB.

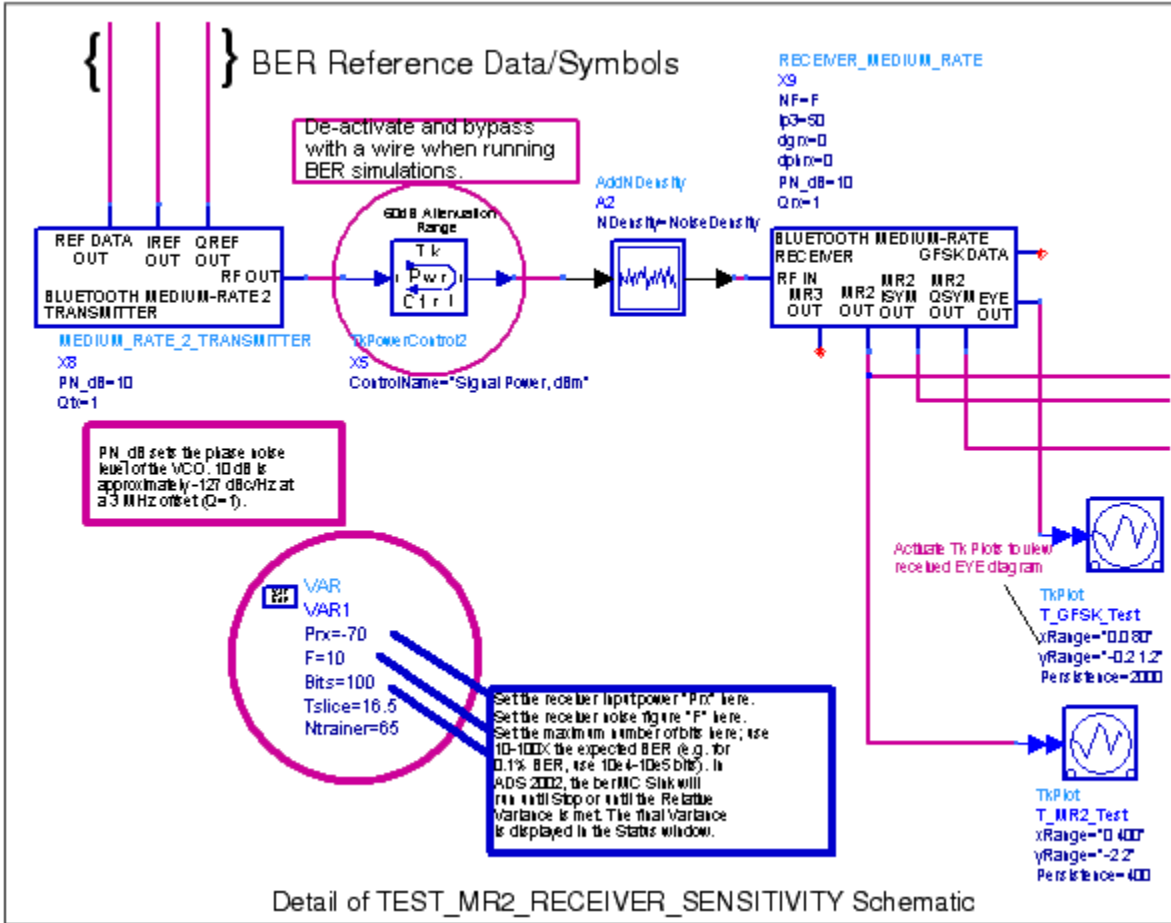

In the following graph,  $E_b/N_0$  is swept for 3 simulations at various values of BT. The 3 datasets are combined into one plot.

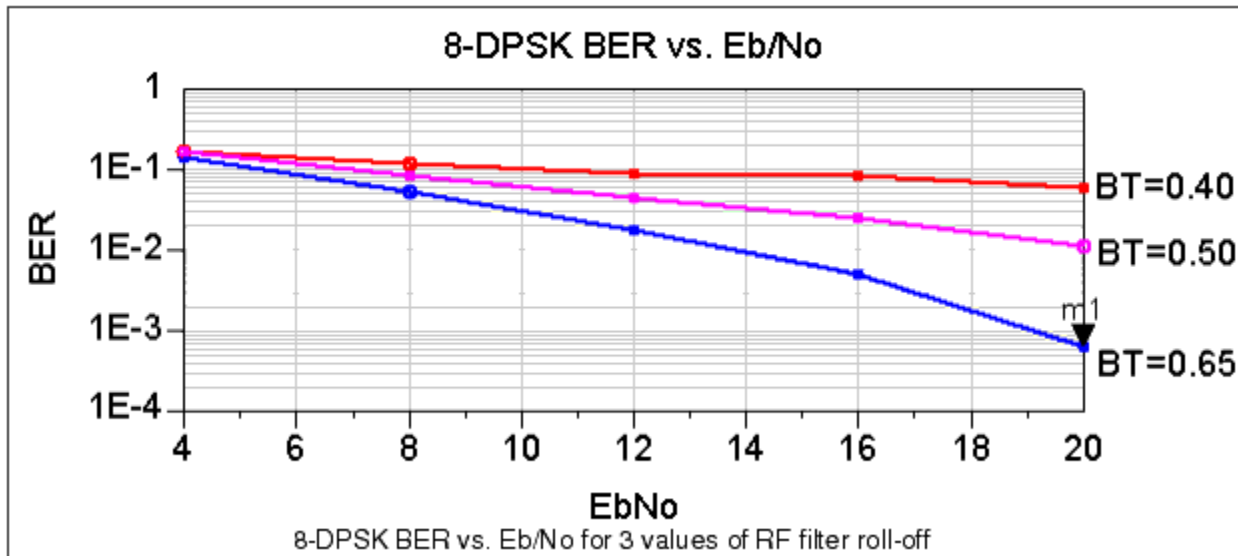

## Bluetooth Interference by 802.11 WLAN Signals

WLAN systems share the same 2.4 GHz band as Bluetooth. At present, the 802.11b system is operational in many regions, using direct-sequence spread-spectrum (DSSS) modulation. A new mode based upon the 802.11a specification, which uses OFDM (Orthogonal Frequency Division Multiplexing) in the 5 GHz band, has been proposed for use in the 2.4 GHz band and named 802.11g. Therefore, it is of interest to be able to investigate the effects of both of these signals on Bluetooth performance. Two test benches are provided for this purpose. However, band-limited noise may be used as an approximate interference source and has been provided as an alternative.

**Note**  
The 802.11b and 802.11a signal sources require the 5-GHz WLAN Design Library.

### Bluetooth\_with\_80211b\_Interference

This test bench provides an interactive slider that varies the power of the interferer as an EYE diagram is presented. Measurement items using the Agilent 89600 Vector Signal Analyzer (available only on PC platforms) are also provided along with setup files; these allow for demodulation and analysis of the Bluetooth and/or 802.11b signals in the interactive mode. Spectrum and BER measurements are also provided.

**Note**  
Simulation time will increase significantly if less than 256 MB of RAM are available.

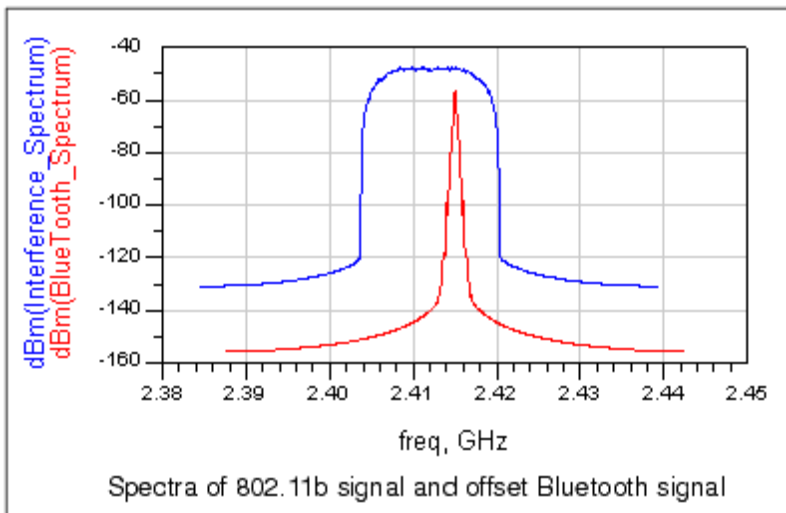

### Bluetooth\_with\_80211g\_Interference

This test bench provides an interactive slider that varies the power of the interferer as an EYE diagram is presented. Measurement items using the Agilent 89600 Vector Signal Analyzer (available only on PC platforms) are also provided along with setup files; these allow for demodulation and analysis of the Bluetooth and/or 802.11g signals in the

interactive mode. Spectrum and BER measurements are also provided.

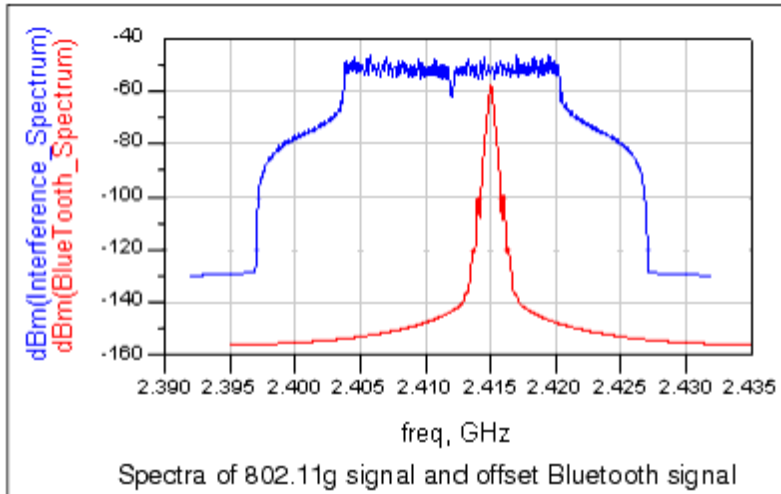

## Test Benches and Subnetworks

Following are details on the available test benches and subnetworks.

### Basic System Test Benches

**TEST\_TX\_SPECTRUM.dsn** The spectrum of the transmitter can be simulated here. The effects of phase noise and Gaussian filter quantization can be observed and compared to the allowed spectral template for various standards.

**TEST\_EYE.dsn** This is a quick simulation to observe the eye diagram with the combined effects of the transmitter and the complete receiver.

**TEST\_TX\_RX\_EYE.dsn** The eye diagram corresponding to the detailed-model (full transmitter and lowIF-receiver with phase noise and filters) end-to-end link can be simulated in this design.

### Component/Subnetwork Evaluations

**SHAPED\_DATA.dsn** This design models a 2 or 4 level Gaussian filtered data source. It includes an initial 2 level training sequence. Only the 2 level mode is applicable to Bluetooth.

**SLICER.dsn** This design extracts the average level of a de-modulated analog signal and uses this level as the slicing reference to a comparator input. The incoming analog signal is sliced into digital bits by the comparator. The slicer behavior is depicted in the display SLICER.

**TEST\_CHANNEL\_FILTER.dsn** The combined behavior of the highpass DC notch filters and the complex channel filter is

simulated in this design.

TEST\_FILTER\_COMPLEX.dsn Complex channel filter behavior is simulated in this design.

TEST\_FILTER\_COMPLEX\_TIME.dsn The time domain response of the complex channel filter is simulated in this design.

TEST\_FILTER\_IMPULSE.dsn The impulse response of circuit level and system level lowpass Bessel filters are compared in this simulation. These lowpass Bessel filters were used in the design of the bandpass complex Bessel filter. The system level model of the filter was preferred to speed the simulation; however, it needed an impulse response that was identical to that of the circuit level filter model.

TEST\_GAUSSIAN\_FIR\_FILTER.dsn The Gaussian filter is implemented digitally as a 17-tap FIR filter with a 6-bit word length for each tap. The impulse response of the filter is simulated in this design. The impulse response is saved to a file. Data from this file is then used to define the tap coefficients of a FIR filter. The display TEST\_GAUSSIAN\_FIR\_FILTER shows the impulse response.

TEST\_LOWIF\_FILTER\_DEMOD.dsn This test bench is used for comparing and optimizing the combination of the channel filter along with various types of poly phase FM demodulators.

TEST\_LOWIF\_FMDEMOD.dsn Similar to the TEST\_LOWIF\_FILTER\_DEMOD.dsn test bench, this design investigates the effect of a polyphase harmonic suppression band pass filter at the output of the hard limiters.

TEST\_LOWIF\_RECEIVER.dsn Similar to the TEST\_LOWIF\_FILTER\_DEMOD.dsn test bench, with this design the entire receiver chain is investigated.

### VCO/PLL (Phase Locked Loop) Investigations

TEST\_PLL\_SS.dsn RF synthesizer reference frequency spurs that occur due to a charge pump mismatch can be observed in this harmonic balance steady state simulation.

TEST\_PLL\_TR.dsn The transient response of the RF synthesizer is simulated in this test bench.

TEST\_PLL\_TR\_linear.dsn This is the main test bench for optimizing the RF synthesizer parameters. The loop filter components are defined in terms of the parameters  $z$  (related to damping constant) and  $f_n$  (related to loop bandwidth). The various results are shown in displays beginning with TEST\_PLL\_TR\_linear.

### Multipath Propagation Test Benches

TEST\_MULTIPATH\_IMPULSE.dsn The impulse response of the multi-path channel is simulated in this design. The frequency response of the channel is obtained, with and without averaging done over any given modulation bandwidth, (e.g., 1 MHz for Bluetooth). The results are shown in the display TEST\_MULTIPATH\_IMPULSE. At frequencies where there is a large relative channel loss without averaging, one can expect severe intersymbol interference due to multi-path. It can also be seen that the correlation bandwidth is approximately the inverse of the

RMS delay spread.

TEST\_MULTIPATH\_POWER.dsn This design varies the channel snapshot, and measures the corresponding modulated signal average power at the output of the channel. The corresponding RMS delay spread values are also available. The display TEST\_MULTIPATH\_POWER\_200\_50\_seed shows the simulation results for a 200 nsec delay spread using tap spacing of 50 nsec. A large number of channel snapshots were taken for the simulation. The pdf and cdf distributions of the multi-path loss are also shown.

TEST\_MULTIPATH\_EYE.dsn This design shows the TK plot of the FM demodulated eye diagram under multi-path conditions. The corresponding multi-path tap coefficients and RMS delay spread values are also shown.

TEST\_MULTIPATH\_EXPONENTIAL.dsn This simulation shows the variations in both the mean power and the instantaneous modulated power for various channel snapshots, along with the corresponding delay spreads.

TEST\_MULTIPATH\_BER.dsn This simulation measures the BER for various channel snapshots. It is useful for computing the channel outage when the signal-to-noise ratio is large. See display TEST\_MULTIPATH\_BER for one particular channel snapshot. It shows the eye diagram, the channel snapshot, the recovered and transmitted bits, the BER, and the RMS delay spread. For channel outage simulations, only the BER should be enabled and the seed and/or frequency varied over a large number of points.

TEST\_MULTIPATH\_BER\_AWGN.dsn Similar to TEST\_MULTIPATH\_BER, it includes additive white Gaussian channel noise. The input signal power level to an ideal receiver (0 dB noise figure) can be set. It shows the BER for both channel noise and multi-path. For channel outage simulations, only the BER should be enabled, along with the channel power measurement if required. For an example, see display TEST\_MULTIPATH\_BER\_AWGN (100 nsec delay spread simulation for channel outage) in which the signal power was set 3 dB above the 1% sensitivity level (AWGN case without multi-path).

TEST\_MULTIPATH\_BER\_NOFILT.dsn Similar to TEST\_MULTIPATH\_BER, this design does not include a channel filter. It shows the ideal BER under large signal-to-noise conditions.

### System Compliance Tests

TEST\_RECEIVER\_ADJ.dsn The receiver adjacent channel rejection is simulated in this test bench. Notably, the rejection at alternate channel frequency, the image frequency, and the alternate channel-to-image frequency are simulated with this test.

TEST\_RECEIVER\_CCR.dsn The co-channel rejection of the receiver can be simulated with this test.

TEST\_RECEIVER\_TEST\_INTERMOD.dsn The effects of two-tone jammers due to third order receiver non-linearity and the reciprocal mixing of these jammers due to phase noise are simulated with this test.

TEST\_RECEIVER\_SENSITIVITY.dsn The receiver sensitivity in an additive white Gaussian noise channel at -174 dBm/Hz is simulated in this design.

## Advanced Design System 2008

TEST\_RECEIVER\_IP2.dsn The effect of out-of-band pulsed jammers on the receiver sensitivity is modeled in this design. The pulsed jammers produce pulsed DC offsets in the baseband quadrature signal paths. The relative power of the jammer and the co-channel rejection of the receiver are the variables that can be set in the top level simulation. Thus, the required IP2 is computed and used in the top level BER simulation.

TEST\_MR2\_RECEIVER\_SENSIVITY.dsn This test bench implements the 2 Mbps mode using interactive control to view EYE diagrams, output data and a real-time BER estimate as the received power is varied via a slider. It may also be configured for BER using Importance Sampling . The transmitter and receiver are inside subnetworks, rather than at the top level design. A berMC measurement is also provided, for determining BER vs. a swept parameter other than Es/No, such as Prx.

TEST\_MR3\_RECEIVER\_SENSIVITY.dsn This test bench implements the 3Mbps mode using interactive control to view EYE diagrams, output data and a real-time BER estimate as the received power is varied via a slider. The transmitter and receiver are inside subnetworks, rather than at the top level design. A berMC measurement is also provided, for determining BER vs. a swept parameter such as Prx or Eb/No.

### Bluetooth with 802.11 Interference Test Benches

Bluetooth\_with\_80211b\_Interference.dsn This test bench provides an interactive slider that varies the power of the interferer as an EYE diagram is presented. Measurement items using the Agilent 89600 Vector Signal Analyzer (available only on PC platforms) are also provided along with setup files; these allow for demodulation and analysis of the Bluetooth and/or DSSS 802.11b signals in the interactive mode. Spectrum and BER measurements are also provided.

Bluetooth\_with\_80211g\_Interference.dsn This test bench provides an interactive slider that varies the power of the interferer as an EYE diagram is presented. Measurement items using the Agilent 89600 Vector Signal Analyzer (available only on PC platforms) are also provided along with setup files; these allow for demodulation and analysis of the Bluetooth and/or OFDM 802.11g signals in the interactive mode. Spectrum and BER measurements are also provided.

### Subnetworks

AGC.dsn This block is used at the output of the MULTIPATH\_EXPONENTIAL block to set the mean output power to a fixed level, instead of letting it vary with each channel snapshot. It measures the mean power of the signal coming from the MULTIPATH\_EXPONENTIAL block in a small time window, then it adjusts the gain to set the mean power at the design level.

AWGN\_CHANNEL.dsn Models the thermal noise of an RF channel at -174 dBm/Hz.

 Note  
AddNDensity, a component available in recent releases of ADS, may be used in placed of AWGN\_CHANNEL. It allows the Noise Density to be directly specified in dBm/Hz.

## Advanced Design System 2008

BER\_TK.dsn Provides real-time calculation of Bit Error Rate by exclusive-OR comparison of two bit streams. Input data should be downsampled to 1 sample per bit. Requires top-level variables Tsave and bitRate.

BroadBandNoiseSource80211b.dsn Provides a filtered noise source that approximates the 802.11b signal; for use when the WLAN Design Library is not available, or when system resources prevent use of the 802.11b signal source.

BroadBandNoiseSource80211g.dsn Provides a filtered noise source that approximates the 802.11g signal; for use when the WLAN Design Library is not available.

CLOCK\_RECOVERY.dsn Used for bit-timing recovery and sampling of sliced data in the receiver. This subnetwork extracts the bit timing from an initial stream of data, and then freezes the recovered block phase after Ntrainer\_sym bits. It also samples the de-modulated bits at the middle point of each using the recovered clock.

DEMFM\_OHZ.dsn A zero-IF polyphase FM demodulator that includes a down converter from low-IF to zero-IF.

DEMFM\_BEES\_MULT.dsn A delay and multiply polyphase FM demodulator using a Bessel filter to implement the delay. This unique method provides exceptional performance when compared to the other demodulators.

DEMFM\_DAMCKT.dsn A differentiate and multiply polyphase FM demodulator at the Analog/RF circuit level.

DEMFM\_DELAY\_MULT.dsn A system level delay and multiply polyphase FM demodulator.

DEMFM\_IQDIGITAL.dsn A polyphase digital FM demodulator.

FILT\_HP\_50KHZ N1.dsn A first-order highpass filter generated from the DSP filter designer in ADS. It is used in RECEIVER.dsn to remove DC following down-conversion.

FILT\_LP\_N1.dsn A first-order lowpass filter.

FILTER\_BESSEL\_COMPLEX.dsn A polyphase bandpass filter with Bessel response.

FILTER\_BESSELckt.dsn A circuit level (Analog/RF) subnetwork used in FILTER\_BESSELckt\_COMPLEX.dsn.

FILTER\_BESSELckt\_COMPLEX.dsn A complex filter subnetwork used in DEMFM\_BEES\_MULT.dsn.

FILTER\_CHEB\_COMPLEX.dsn A complex filter subnetwork used as a channel filter in RECEIVER.dsn.

MEDIUM\_RATE\_2\_TRANSMITTER.dsn A 2Mbps transmitter using Pi/4-DQPSK modulation with a variable-length GFSK preamble.

MEDIUM\_RATE\_3\_TRANSMITTER.dsn A 3 Mbps transmitter using 8-DPSK modulation with a variable-length GFSK preamble.

## Advanced Design System 2008

MIXER\_COMPLEX.dsn A complex mixer used in the system-level implementation of polyphase bandpass filters.

MULTIPATH\_EXPONENTIAL.dsn This design implements an exponential power decay multi-path channel model that is widely used for indoor propagation. The mean excess delay and tap delay can be specified in microseconds. Each tap coefficient has a Rayleigh power distribution and a uniform phase distribution. For a specified value of time Tburst, the channel snapshot is kept fixed. For the next Tburst duration, a new channel snapshot is taken. The tap coefficients for each snapshot, the corresponding values of the RMS delay spread and the mean excess delay are all available. TK plots for these measurements can also be enabled.

MULT\_RF\_BB.dsn A subnetwork used in MULTIPATH\_EXPONENTIAL.

MULTIPATH\_TAP\_C.dsn A subnetwork used in MULTIPATH\_EXPONENTIAL to generate random noise and phase characteristics according to the exponential tap coefficients.

OSC\_PN.dsn A system-level RF oscillator with phase noise.

OSC\_PN\_FMMOD.dsn A baseband phase noise generator used as modulation input voltage to an FM modulator.

PLL\_TR\_linear.dsn Used in TEST\_PLL\_NOISE and TEST\_PLL\_TR\_linear.

POWER.dsn Output is a signal that has a value equal to the input signal power in dBm. It is useful in evaluating the effect of multi-path fading.

POWER\_GATED.dsn Time-gated version of POWER.dsn.

TRANSMITTER.dsn This transmitter is used in most test benches. It is constructed using SHAPED\_DATA and OSC\_PN\_FMMOD, plus an ideal FM modulator. Top-level parameters include the phase noise level and Q.

RECEIVER.dsn The Bluetooth receiver has a front-end low-noise amplifier that models the noise figure and the third-order intercept point. It is followed by a quadrature amplitude demodulator that includes the phase and gain imbalance. The local oscillator for this demodulator/down converter includes the phase noise. The output of the quadrature amplitude demodulator is a 1 MHz low IF complex signal comprising the in-phase and quadrature phase signals. These signals are highpass filtered to remove DC offsets due to local oscillator self mixing, and to remove time varying DC offsets as a result of second-order non-linearity effects on out of band pulsed jammers. After the highpass filters, there is a complex channel filter with quadrature inputs and outputs. This filter is centered at 1 MHz and has an asymmetric positive and negative frequency response. The quadrature outputs of the channel filter are hard limited and then demodulated by a complex FM demodulator. This FM demodulator can be implemented in several ways. The preferred solution is to have a complex Bessel filter that implements a delay, with the delay signals cross-multiplied with the input signals and then summed at the output. The combination of the complex channel filter and this Bessel filter have to be carefully designed to produce the minimum distortion of the de-modulated signal. The demodulator and signal have unwanted high-frequency components that are removed by the data filter. The data slicer then converts the demodulated analog signal into digital bits.

RECEIVER\_IP2.dsn The effect of out of band pulsed jammers on receiver sensitivity is modeled in the

## Advanced Design System 2008

RECEIVER\_IP2.dsn design, otherwise similar to RECEIVER.dsn. The pulsed jammers produce pulsed DC offsets in the baseband quadrature signal paths. The relative power of the jammer and the co-channel rejection of the receiver are variables that can be set in the TEST\_RECEIVER\_IP2.dsn top-level simulation. Based on this, the required IP2 is calculated and used in the top level BER simulation.

RECEIVER\_MEDIUM\_RATE.dsn A composite subnetwork which contains receivers for GFSK and both medium rate formats.

SHAPED\_DATA.dsn This subnetwork implements both 2 and 4 level pulse shaping for GFSK modulation. A {10101010.....} preamble, its length determined by the Preamble parameter defined in a VAR block in the top-level design, is inserted at the start of simulation.

 **Note**  
This component has been slightly modified in Version 2.1.1 in that a IntToFloat component has been inserted between the Bits and Trainer components. Under some conditions, ADS will report an error concerning signal types without this added component.

sub\_80211g\_Source.dsn Part of the 802.11g Signal Source

sub\_80211b\_5p5Mbps\_CCK\_Source.dsn Part of the 802.11b Signal Source

sub\_CRC\_Generator.dsn, sub\_DataCounter.dsn and sub\_ScrambleWithReset.dsn Used within

sub\_80211b\_5p5Mbps\_CCK\_Source.dsn