



Agilent Technologies

ADS 2008
January 2008
HSDPA Design Library

Advanced Design System 2008

© Agilent Technologies, Inc. 2000-2008

395 Page Mill Road, Palo Alto, CA 94304 U.S.A.

No part of this manual may be reproduced in any form or by any means (including electronic storage and retrieval or translation into a foreign language) without prior agreement and written consent from Agilent Technologies, Inc. as governed by United States and international copyright laws.

Acknowledgments

Mentor Graphics is a trademark of Mentor Graphics Corporation in the U.S. and other countries. Microsoft®, Windows®, MS Windows®, Windows NT®, and MS-DOS® are U.S. registered trademarks of Microsoft Corporation. Pentium® is a U.S. registered trademark of Intel Corporation. PostScript® and Acrobat® are trademarks of Adobe Systems Incorporated. UNIX® is a registered trademark of the Open Group. Java™ is a U.S. trademark of Sun Microsystems, Inc. SystemC® is a registered trademark of Open SystemC Initiative, Inc. in the United States and other countries and is used with permission. MATLAB® is a U.S. registered trademark of The Math Works, Inc.. HiSIM2 source code, and all copyrights, trade secrets or other intellectual property rights in and to the source code in its entirety, is owned by Hiroshima University and STARC.

Errata The ADS product may contain references to "HP" or "HPEESOF" such as in file names and directory names. The business entity formerly known as "HP EEsof" is now part of Agilent Technologies and is known as "Agilent EEsof". To avoid broken functionality and to maintain backward compatibility for our customers, we did not change all the names and labels that contain "HP" or "HPEESOF" references.

Warranty The material contained in this document is provided "as is", and is subject to being changed, without notice, in future editions. Further, to the maximum extent permitted by applicable law, Agilent disclaims all warranties, either express or implied, with regard to this manual and any information contained herein, including but not limited to the implied warranties of merchantability and fitness for a particular purpose. Agilent shall not be liable for errors or for incidental or consequential damages in connection with the furnishing, use, or performance of this document or of any information contained herein. Should Agilent and the user have a separate written agreement with warranty terms covering the material in this document that conflict with these terms, the warranty terms in the separate agreement shall control.

Technology Licenses The hardware and/or software described in this document are furnished under a license and may be used or copied only in accordance with the terms of such license. Portions of this product include the SystemC software licensed under Open Source terms, which are available for download at <http://systemc.org/>. This software is redistributed by Agilent. The Contributors of the SystemC software provide this software "as is" and offer no warranty of any kind, express or implied, including without limitation warranties or conditions or title and non-infringement, and implied warranties or conditions merchantability and fitness for a particular purpose. Contributors shall not be liable for any damages of any kind including without limitation direct, indirect, special, incidental and consequential damages, such as lost profits. Any provisions that differ from this disclaimer are offered by Agilent only.

Restricted Rights Legend If software is for use in the performance of a U.S. Government prime contract or subcontract, Software is delivered and licensed as "Commercial computer software" as defined in DFAR 252.227-7014 (June 1995), or as a "commercial item" as defined in FAR 2.101(a) or as "Restricted computer software" as defined in FAR 52.227-19 (June 1987) or any equivalent agency regulation or contract clause. Use, duplication or disclosure of Software is subject to Agilent Technologies' standard commercial license terms, and non-DOD Departments and Agencies of the U.S. Government will receive no greater than Restricted Rights as defined in FAR 52.227-19(c)(1-2) (June 1987). U.S. Government users will receive no greater than Limited Rights as defined in FAR 52.227-14 (June 1987) or DFAR 252.227-7015 (b)(2) (November 1995), as applicable in any technical data.

Contents

- About HSDPA Design Library
- - 3GPP Technical Specifications Supported
 - HSDPA Systems
 - - HSDPA Downlink Transceiver Physical Layer Block Diagram
 - HSDPA Component Libraries Overview
 - - Multiplexers & Coders Components
 - - Demultiplexers & Decoders Components
 - - Measurement Components
 - - Receiver Components
 - - Signal Source Components
 - Design Examples
 - Glossary of Terms
 - References
- HSDPA Components
- - HSDPA_Bits
 - - Symbol
 - - Parameters
 - - Pin Inputs
 - - Pin Outputs
 - - Notes/Equations
 - - References
 - HSDPA_BitScrambling
 - - Symbol
 - - Parameters
 - - Pin Inputs
 - - Pin Outputs
 - - Notes/Equations
 - - References
 - HSDPA_ChDecoder
 - - Symbol
 - - Parameters
 - - Pin Inputs
 - - Pin Outputs
 - - Notes/Equations
 - - References
 - HSDPA_ChEncoder
 - - Symbol
 - - Parameters
 - - Pin Inputs
 - - Pin Outputs
 - - Notes/Equations
 - - References
 - HSDPA_ChEstimate
 - - Symbol
 - - Parameters
 - - Pin Inputs

- Pin Outputs
- Notes/Equations
- References
- HSDPA_CodeBlkDeseg
 - - Symbol
 - Parameters
 - Pin Inputs
 - Pin Outputs
 - Notes/Equations
 - References
- HSDPA_CRCDecoder
 - - Symbol
 - Parameters
 - Pin Inputs
 - Pin Outputs
 - Notes/Equations
 - References
- HSDPA_CRCEncoder
 - - Symbol
 - Parameters
 - Pin Inputs
 - Pin Outputs
 - Notes/Equations
 - References
- HSDPA_Deinterleaver
 - - Symbol
 - Parameters
 - Pin Inputs
 - Pin Outputs
 - Notes/Equations
 - References
- HSDPA_Despread
 - - Symbol
 - Parameters
 - Pin Inputs
 - Pin Outputs
 - Notes/Equations
 - References
- HSDPA_DL_Rake
 - - Symbol
 - Parameters
 - Pin Inputs
 - Pin Outputs
 - Notes/Equations
 - HSDPA_DL_RakeReceiver Schematic
 - References
- HSDPA_DL_Receiver
 - - Symbol
 - Parameters
 - Pin Inputs

- Pin Outputs
- Notes/Equations
- - HSDPA_DL_Receiver Schematic
- References
- HSDPA_DL_ReceiverRF
- - Symbol
- Parameters
- Pin Inputs
- Pin Outputs
- Notes/Equations
- - HSDPA_DL_ReceiverRF Schematic
- References
- HSDPA_DL_Source
- - Symbol
- Parameters
- Pin Inputs
- Pin Outputs
- Notes/Equations
- - HSDPA_DL_Source Schematic
- - Downlink Physical Channels
- References
- HSDPA_DL_SourceRF
- - Symbol
- Parameters
- Pin Inputs
- Pin Outputs
- Notes/Equations
- - HSDPA_DL_SourceRF Schematic
- - Downlink Physical Channels
- References
- HSDPA_DownSample
- - Symbol
- Parameters
- Pin Inputs
- Pin Outputs
- Notes/Equations
- References
- HSDPA_EVM
- - Symbol
- Parameters
- Pin Inputs
- Notes/Equations
- - HSDPA_EVM Schematic
- References
- HSDPA_Interleaver
- - Symbol
- Parameters
- Pin Inputs
- Pin Outputs
- Notes/Equations

- References
- HSDPA_OCNS_Gain
 - - Symbol
 - Parameters
 - Pin Inputs
 - Pin Outputs
 - Notes/Equations
 - References
- HSDPA_PathSearch
 - - Symbol
 - Parameters
 - Pin Inputs
 - Pin Outputs
 - Notes/Equations
 - References
- HSDPA_PDSCH_1_4
 - - Symbol
 - Parameters
 - Pin Inputs
 - Pin Outputs
 - Notes/Equations
 - - HSDPA_PDSCH_1_4 Schematic
 - References
- HSDPA_PDSCH_Decoder
 - - Symbol
 - Parameters
 - Pin Inputs
 - Pin Outputs
 - Notes/Equations
 - - HSDPA_PDSCH_Decoder Schematic
 - References
- HSDPA_PDSCH_WithFEC
 - - Symbol
 - Parameters
 - Pin Inputs
 - Pin Outputs
 - Notes/Equations
 - - HSDPA_PDSCH_WithFEC Schematic
 - References
- HSDPA_PDSCH_WithoutFEC
 - - Symbol
 - Parameters
 - Pin Outputs
 - Notes/Equations
 - - HSDPA_PDSCH_WithoutFEC Schematic
 - References
- HSDPA_PhCH_Demap
 - - Symbol
 - Parameters
 - Pin Inputs

- Pin Outputs
- Notes/Equations
 - QPSK modulation mapping
 - 16QAM modulation mapping
- References
- HSDPA_PowerAdjust
 - - Symbol
 - Parameters
 - Pin Inputs
 - Pin Outputs
 - Notes/Equations
 - References
- HSDPA_RakeCombine
 - - Symbol
 - Parameters
 - Pin Inputs
 - Pin Outputs
 - Notes/Equations
 - References
- HSDPA_RateDematch
 - - Symbol
 - Parameters
 - Pin Inputs
 - Pin Outputs
 - Notes/Equations
 - References
- HSDPA_RateMatch
 - - Symbol
 - Parameters
 - Pin Inputs
 - Pin Outputs
 - Notes/Equations
 - References
- HSDPA_SCCH
 - - Symbol
 - Parameters
 - Pin Inputs
 - Pin Outputs
 - Notes/Equations
 - HSDPA_SCCH Schematic
 - Structure of the HS-SCCH (Ref: 3GPP TS 25.211 5.3.3.12)
 - Coding chain for HS-SCCH
 - References
- HSDPA_SCCH_1_4
 - - Symbol
 - Parameters
 - Pin Inputs
 - Pin Outputs
 - Notes/Equations
 - HSDPA_SCCH_1_4 Schematic

- Structure of the HS-SCCH (Ref: 3GPP TS 25.211 5.3.3.12)
 - Coding chain for HS-SCCH
- References
- HSDPA_SCCH_Decoder
 - - Symbol
 - Parameters
 - Pin Inputs
 - Pin Outputs
 - Notes/Equations
 - - HSDPA_SCCH_Decoder Schematic
 - References
- HSDPA_SCCH_DeRM
 - - Symbol
 - Pin Inputs
 - Pin Outputs
 - Notes/Equations
 - References
- HSDPA_SCCH_ParaCalc
 - - Symbol
 - Parameters
 - Pin Inputs
 - Pin Outputs
 - Notes/Equations
 - - Coding chain for HS-SCCH
 - References
- HSDPA_SCCH_RM
 - - Symbol
 - Pin Inputs
 - Pin Outputs
 - Notes/Equations
 - References
- HSDPA_SCH
 - - Symbol
 - Parameters
 - Pin Outputs
 - Notes/Equations
 - References
- HSDPA_Spread
 - - Symbol
 - Parameters
 - Pin Inputs
 - Pin Outputs
 - Notes/Equations
 - References
- HSDPA_STTD_Decoder
 - - Symbol
 - Parameters
 - Pin Inputs
 - Pin Outputs
 - Notes/Equations

- Constellation re-arrangement for 16QAM
 - References
- HSDPA_STTD_Encoder
 - - Symbol
 - Parameters
 - Pin Inputs
 - Pin Outputs
 - Notes/Equations
 - Generic block diagram of STTD encoder for QPSK
 - Constellation re-arrangement for 16QAM
 - Generic block diagram of STTD encoder for 16QAM
 - References
- HSDPA_Throughput
 - - Symbol
 - Parameters
 - Pin Inputs
 - Pin Outputs
 - Notes/Equations
 - References
- HSDPA Base Station Transmitter Design Examples
 - - VAR Parameters
 - Maximum Power Measurements
 - - Features
 - Description
 - BS_Tx_MaxPower.dsn Schematic
 - Simulation Results
 - Maximum Power Curve
 - Benchmark
 - Occupied Bandwidth Measurements
 - - Features
 - Description
 - BS_Tx_OccupiedBW.dsn Schematic
 - Simulation Results
 - Occupied Bandwidth Curve
 - Benchmark
 - Complementary Cumulative Distribution Function Measurements
 - - Features
 - Description
 - BS_Tx_CCDF.dsn Schematic
 - Simulation Results
 - Base Station Transmitter CCDF Curve
 - Benchmark
 - Transmitter Spectrum Emissions Measurements
 - - Feature
 - Description
 - BS_Tx_Spec_Emission.dsn Schematic
 - Notes
 - Simulation Results
 - Spectrum Emission Curves
 - Benchmark

Advanced Design System 2008

- Adjacent Channel Leakage Power Measurements in Frequency Domain
- - Features
- Description
 - - BS_Tx_ACLR.dsn Schematic
 - - 3GPPFDD_RF_ACLR Schematic
- Simulation Results
 - - Base Station Transmitter Spectrum and ACLR Performance
- Benchmark
- Transmitter EVM Measurements
- - Features
- Description
 - - BS_Tx_EVM.dsn Schematic
- Simulation Results
 - - EVM measurement
- Benchmark
- Transmitter Peak Code Domain Error Measurements
- - Features
- Description
 - - BS_Tx_Pk_Code_Error.dsn Schematic
 - - 3GPPFDD_RF_PCDE.dsn Schematic
- Simulation Results
 - - Peak Code Domain Error of Base Station Transmitter
- Benchmark
- Connection with 89600 VSA Software
- - Features
- Description
 - - BS_Tx_VSA.dsn Schematic
- Simulation Results
 - - 89600 VSA software results
- Benchmark
- References
- HSDPA User Equipment Receiver Design Examples
 - - References
 - HS-DSCH Demodulation Performance Measurement
 - - Features
 - Description
 - - UE_Rx_Demodulation_Hset1_PA3_QPSK.dsn Schematic
 - - UE_Rx_Demodulation_Hset2_PB3_16QAM.dsn Schematic
 - - UE_Rx_Demodulation_Hset3_VA30_16QAM.dsn Schematic
 - - UE_Rx_Demodulation_Hset4_PB3_QPSK.dsn Schematic
 - - UE_Rx_Demodulation_Hset5_VA120_QPSK.dsn Schematic
 - - UE_Rx_Demodulation_Hset6_PA3_16QAM.dsn Schematic
 - Simulation Results
 - - Throughput Results (R) for User Equipment Demodulation Performance Measurement (Fading) Hset1 under PA3 channel with QPSK modulation
 - - Throughput Results (R) for User Equipment Demodulation Performance Measurement (Fading) Hset2 under PB3 channel with 16QAM modulation
 - - Throughput Results (R) for User Equipment Demodulation Performance Measurement (Fading) Hset3 under VA30 channel with 16QAM modulation
 - - Throughput Results (R) for User Equipment Demodulation Performance Measurement (Fading)

- Hset4 under PB3 channel with QPSK modulation
- Throughput Results (R) for User Equipment Demodulation Performance Measurement (Fading)
- Hset5 under VA120 channel with QPSK modulation
- Throughput Results (R) for User Equipment Demodulation Performance Measurement (Fading)
- Hset6 under PA3 channel with 16QAM modulation
- Benchmark
- HS-SCCH Detection Performance Measurements
 - - Features
 - Description
 - - UE_Rx_HSSCCH_Detection_TS1_PA3.dsn Schematic
 - Simulation Results
 - - HSDPA HS-SCCH Detection Single Link Performance Measurements
 - Benchmark
- Maximum Input Level Throughput Measurements
 - - Features
 - Description
 - - UE_Rx_MaxLevel.dsn Schematic
 - Simulation Results
 - - HSDPA Maximum Input Level Measurement Result
 - Benchmark

About HSDPA Design Library

The HSDPA Wireless Library is designed for High Speed Downlink Packet Access (HSDPA), which is an enhancement to 3GPP downlink and defined in release 5 of 3GPP specification. This design library focuses on the physical layer aspects of HSDPA systems and is intended to be a baseline system for designers to get an idea of what nominal or ideal system performance would be. Evaluations can be made regarding degraded system performance due to system impairments that may include non-ideal component performance.

The transport channels and physical channels defined in previous versions of 3GPP specification s are also supported by HSDPA design library. But they are treated as the accessory channels because HSDPA design library focus on the modeling and test of channels defined in release 5, say HSDPA. The test for the scenario with only 3GPP FDD and without HSDPA can be implemented by 3GPP design library.

3GPP Technical Specifications Supported

3GPP committee updates 3GPP technical specifications every 3 months. Each of 3GPP specification is further classified by features: release '99 (Version 3.xx), release 4 (Version 4.xx), release 5 (Version 5.xx) and release 6 (Version 6.xx). Basically, the contents defined in lower version specifications typically duplicate the contents from release '99, release 4 and release 5 that are published simultaneously.

The HSDPA design library is compliant with 3GPP release 6 technical specifications published in 2006-03.

HSDPA design library also reuses some 3GPP design library models in the application level. The technical specifications of those models were published in 2002-03 for release '99 content. The version may be changed if 3GPP design library is updated.

HSDPA Systems

HSDPA offers peak downlink data rates up to 14 Mbps and increases the system capacity for downlink packet data. The increased data rates and improved capacity result in shorter delays for the end-users. This is particularly important for some multimedia applications such as interactive games. The high data rates also benefit streaming and web browsing applications. At the same time, HSDPA is backward-compatible with 3GPP FDD specification.

In the downlink, two new physical channels HS-PDSCH and HS-SCCH are defined for HSDPA; and in the uplink, one new physical channel HS-DPCCH is defined for HSDPA. HS-PDSCH carries downlink data from HS-DSCH, which is the transport channel defined for HSDPA; HS-SCCH carries downlink signalling; and HS-DPCCH carries uplink signalling.

The HSDPA Downlink transmitter and receiver structure block diagram for HS-PDSCH is shown below.

HSDPA Downlink Transceiver Physical Layer Block Diagram

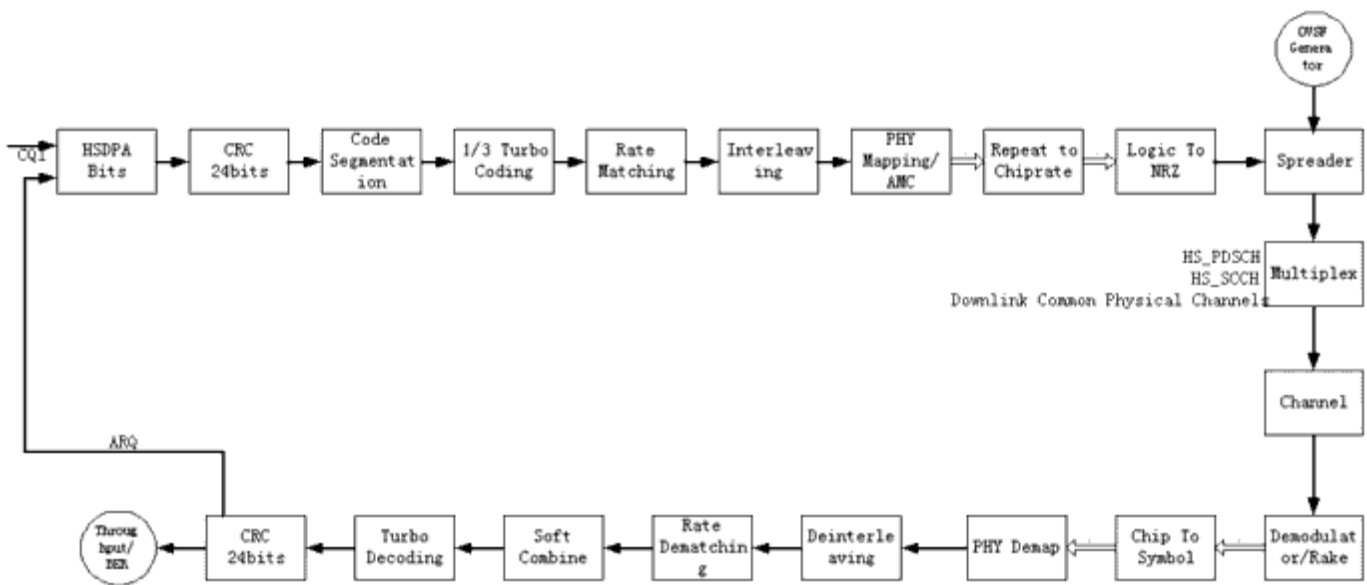

HSDPA Component Libraries Overview

Multiplexers & Coders Components

- CRC
- Bit scrambling
- Turbo coding for HS-DSCH
- Convolutional coding for HS-SCCH
- Rate matching
- Interleaving
- STTD encoding
- Physical channel mapping
- Spreading

Demultiplexers & Decoders Components

- Physical channel demapping
- STTD decoding
- Turbo decoding
- Deinterleaving
- CRC decoding

Measurement Components

- Throughput measurement
- EVM measurement

Receiver Components

- Rake receiver for HSDPA downlink
- Baseband receiver for HSDPA downlink
- RF receiver for HSDPA downlink

Signal Source Components

- Bit signal source with HARQ and AMC functionality

- HS-PDSCH signal source with FEC
- HS-PDSCH signal source without FEC
- HS-SCCH signal source
- HSDPA baseband signal source
- HSDPA RF signal source

Design Examples

The RF characteristics can be measured using the HSDPA design library. RF measurements for user equipment (UE) are defined in [Reference \[5\]](#); test methods are described in [Reference \[8\]](#). For base station (BS), the RF characteristics are defined in [Reference \[6\]](#); test methods are described in [Reference \[7\]](#).

The HSDPA_BS_Tx_prj project shows base station transmitter performance measurements. Designs for these measurements include:

- BS_Tx_ACLR.dsn
- BS_Tx_CCDF.dsn
- BS_Tx_EVM.dsn
- BS_Tx_MaxPower.dsn
- BS_Tx_OccupiedBW.dsn
- BS_Tx_Pk_Code_Error.dsn
- BS_Tx_Spec_Emission.dsn
- BS_Tx_VSA.dsn

The HSDPA_UE_Rx_prj project shows user equipment receiver performance. Designs for these measurements include:

- UE_Rx_Demodulation_Hset1_PA3_QPSK.dsn
- UE_Rx_Demodulation_Hset2_PB3_16QAM.dsn
- UE_Rx_Demodulation_Hset3_VA30_16QAM.dsn
- UE_Rx_Demodulation_Hset4_PB3_QPSK.dsn
- UE_Rx_Demodulation_Hset5_VA120_QPSK.dsn
- UE_Rx_Demodulation_Hset6_PA3_16QAM.dsn
- UE_Rx_HSSCCH_Detection_TS1_PA3.dsn
- UE_Rx_MaxLevel.dsn

Glossary of Terms

3GPP	third generation partnership project
ACLR	adjacent channel leakage power ratio
AWGN	additive white Gaussian noise

Advanced Design System 2008

CCDF	complementary cumulative distribution function
DCH	dedicated channel
DPDCH	dedicated physical data channel
HS-DSCH	high speed downlink shared channel
HS-PDSCH	high speed physical downlink shared channel
HS-SCCH	shared control channel for HS-DSCH
HS-DPCCH	dedicated physical control channel (uplink) for HS-DSCH
EVM	error vector magnitude
FDD	frequency division duplex
FEC	forward error correction
HSDPA	high speed downlink packet access
HSUPA	high speed uplink packet access
PA	power amplifier
PER	packet error rate
QPSK	quadrature phase shift keying
RF	radio frequency
RX	receive or receiver
TTI	transmission timing interval
TX	transmit or transmitter

References

1. 3GPP Technical Specification TS 25.211, "Physical channels and mapping of transport channels onto physical channels (FDD)," Version 6.7.0, Dec. 2005.
2. 3GPP Technical Specification TS 25.212, "Multiplexing and channel coding (FDD)," Version 6.7.0, Dec. 2005.
3. 3GPP Technical Specification TS 25.213, "Spreading and modulation (FDD)," Version 6.4.0, Sept. 2005.
4. 3GPP Technical Specification TS 25.214, "Physical layer procedures (FDD)," Version 6.7.1, Dec. 2005.
5. 3GPP Technical Specification TS 25.101, "UE Radio transmission and Reception (FDD)," Version 6.10.0, Dec. 2005.
6. 3GPP Technical Specification TS 25.104, "UTRA (BS) FDD: Radio transmission and Reception," Version 6.11.0, Dec. 2005.
7. 3GPP Technical Specification TS 25.141, "Base station conformance test," Version 6.12.0, Dec. 2005.
8. 3GPP Technical Specification TS 34.121, "Radio transmission and reception (FDD)," Version 6.3.0, Dec. 2005.

HSDPA Components

HSDPA_Bits

HSDPA information bit generator

Symbol

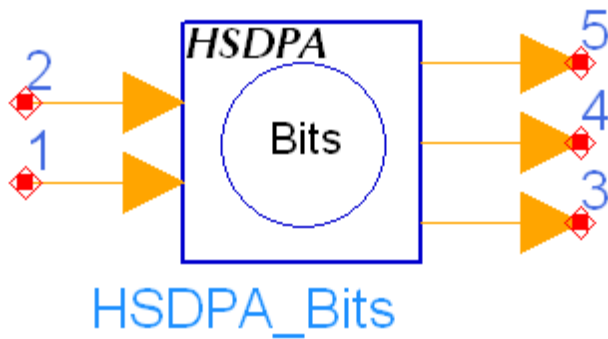

Description: HSDPA information bit generator

Library: HSDPA, Signal Sources

Class: SDFHSDPA_Bits

Parameters

Name	Description	Default	Type	Range
UE_Category	UE Category: Category_1, Category_2, Category_3, Category_4, Category_5, Category_6, Category_7, Category_8,	Category_1	enum	

Advanced Design System 2008

	Category_9, Category_10, Category_11, Category_12			
TransBlockSize	Transport block size	3202	int	[1, 25558]
NumHARQ	Number of HARQ processes	1	int	[1, 6]
RVSeq	Redundancy and constellation version coding sequence	{0, 2, 5, 6}	int array	[0, 7]
DataPattern	Source data pattern: Random, PN9, PN15, Repeat Bits	Random	enum	
RepeatBitValue	Repeating data value	0x0001	int	[0, 65535]
RepeatBitPeriod	Repeating data period	2	int	[1, 16]
TTIPattern	inter-TTI pattern	{1, 1, 1, 1, 1, 1}	int array	[0, 1]

Pin Inputs

Pin	Name	Description	Signal Type
1	CQI	channel quality indicator	int
2	ARQ	automatic repeat request	int

Pin Outputs

Pin	Name	Description	Signal Type
3	DataOut	data out	int
4	RV	redundancy version	int
5	nd	new data indicator	int

Notes/Equations

1. This model is used to generate information bits for HS-DSCH block by block, and also supports HARQ and AMC. Each firing, MaxTransBlockSize tokens are generated at pin Output, one token at pin RV and one token at pin nd, while one token is consumed at pin CQI or ARQ if either is connected. If pin CQI is connected, this model is in AMC (Adaptive Modulation and Coding) mode and if pin ARQ is connected, this model is in HARQ (Hybrid ARQ) mode. Note that pin CQI and ARQ are optional. If they are not connected, no token is consumed. But they cannot be connected simultaneously, which means this model does not support HARQ and AMC simultaneously. If pin

CQI is not connected, MaxTransBlockSize is equal to TransBlockSize and all the MaxTransBlockSize data bits are for HS-DSCH. If pin CQI is connected, MaxTransBlockSize is equal to the maximum transport block size the UE_Category supports, and the number of data bits for HS-DSCH is determined by the input CQI value according to Table 7 of 6A.2 in [Reference \[2\]](#). If the number is less than MaxTransBlockSize, 0s are padded.

2. The input value of CQI is in the range of 1 to 30. In AMC mode, there is no re-transmission, RV is always the first element of the RVSeq, and nd is always 1.
3. The input value of ARQ is in the range of 0 to 1. If the input of ARQ is 0, it means NACK and the correspondent packet are not received correctly. Otherwise, it means ACK and the correspondent packet are received correctly. If ACK is received, BS will transmit new packet within current HARQ process. If NACK is received, BS will re-transmit the packet. The maximum re-transmission number is determined by the size of RVSeq. if re-transmission number is larger than the size of RVSeq, then this packet will be discarded and a new packet will be transmitted. The delay for ARQ depends on NumHARQ and TTIPattern. User can set the value of NumHARQ and TTIPattern. For example, if the NumHARQ set to 4 and TTIPattern set to {1,0,0,1,0,0}, UE will get the ARQ signal of the first packet when it send the ninth packet.
The output of RV is the redundancy version of current packet. If it is a new packet, RV is the first element of RVSeq; If not, RV can be the second, third,...,last element of RVSeq incrementally.
4. For the DataPattern parameter:
 - if Random is selected, random bits are generated.
 - if PN9 is selected, a 511-bit pseudo-random test pattern is generated according to CCITT Recommendation O.153
 - if PN15 is selected, a 32767-bit pseudo-random test pattern is generated according to CCITT Recommendation O.151
 - if Repeat Bits is selected, the data pattern depends on RepeatBitValue and RepeatBitPeriod. The RepeatBitPeriod length of LSB of RepeatBitValue will be repeated and filled in the data packet.

References

1. 3GPP Technical Specification TS 25.211, "Physical channels and mapping of transport channels onto physical channels (FDD)," Version 6.7.0, Dec. 2005.
2. 3GPP Technical Specification TS 25.212, "Multiplexing and channel coding (FDD)," Version 6.7.0, Dec. 2005.
3. 3GPP Technical Specification TS 25.213, "Spreading and modulation (FDD)," Version 6.4.0, Sept. 2005.
4. 3GPP Technical Specification TS 25.214, "Physical layer procedures (FDD)," Version 6.7.1, Dec. 2005.
5. 3GPP Technical Specification TS 25.104, "UTRA (BS) FDD: Radio transmission and Reception," Version 6.11.0, Dec. 2005.
6. 3GPP Technical Specification TS 25.141, "Base station conformance test," Version 6.12.0, Dec. 2005.
7. CCITT, Recommendation O.151(10/92).
8. CCITT, Recommendation O.153(10/92).

HSDPA_BitScrambling

HSDPA bit scrambling

Symbol

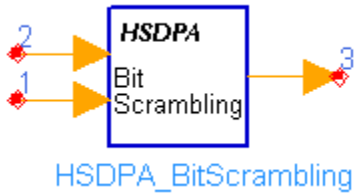

Description: Bit scrambler

Library: HSDPA, Multiplexers & Coders

Class: SDFHSDPA_BitScrambling

Derived From: HSDPA_DSCH_Base

Parameters

Name	Description	Default	Type	Range
UE_Category	: Category_1, Category_2, Category_3, Category_4, Category_5, Category_6, Category_7, Category_8, Category_9, Category_10, Category_11, Category_12	Category_1	enum	
TransBlockSize	Transport block size	3202	int	[1, max transport block size] †

† Refer to the [FDD E-DCH physical layer categories](#) in the [HSUPA Design Library](#) documentation.

Pin Inputs

Pin	Name	Description	Signal Type
1	CQI	channel quality indicator	int
2	DataIn	data in	int

Pin Ouputs

Pin	Name	Description	Signal Type
-----	------	-------------	-------------

3	DataOut	data out	int
---	---------	----------	-----

Notes/Equations

1. This model is used to implement bit scrambling on HS-DSCH defined in 4.5.1a in [1].
Each firing, Ndata DataOut tokens are generated while Ndata DataIn tokens consumed. If CQI pin is connected and has input tokens, $Ndata = N_TransBlockSize + 24$. N_TransBlockSize is the maximum transport block size, which the UE of specified category can support according to Table 7 of 6A.2 in [2]. If the CQI pin is unconnected, $Ndata = TransBlockSize + 24$, where TransBlockSize is a parameter of this model.
2. The TransBlockSize parameter determines the transport block size of HS-DSCH. The largest transport block size is 27,952 bits, which corresponds to the highest data rate of 13.976 Mb/s ($27,952 \text{ bits} / 2 \text{ ms} = 13.976 \text{ Mb/s}$). This data rate is obtained by using 16 QAM, an effective code rate of 0.9714, and 15 HS-PDSCHs.
3. The input pin CQI is optional. If connected, the input value of CQI should be in the range of 1 to 30.

References

1. 3GPP Technical Specification TS 25.212, "Multiplexing and channel coding (FDD)," Version 6.7.0, Dec. 2005.
2. 3GPP Technical Specification TS 25.214, "Physical layer procedures (FDD)," Version 6.7.1, Dec. 2005.

HSDPA_ChDecoder

HSDPA Channel Decoder

Symbol

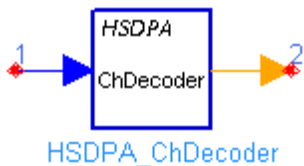

Description: Turbo decoder

Library: HSDPA, Demultiplexers & Decoders

Advanced Design System 2008

Class: SDFHSDPA_ChDecoder

Derived From: HSDPA_DSCH_Base

Parameters

Name	Description	Default	Type	Range
TransBlockSize	Transport block size	3202	int	[1, max transport block size] †
TC_Iteration	Turbo code decoder iteration number	4	int	[1, 10]
TC_Alfa	Alfa of lowpass filter	0.4	real	

† Refer to the [FDD E-DCH physical layer categories](#) in the [HSUPA Design Library](#) documentation.

Pin Inputs

Pin	Name	Description	Signal Type
1	DataIn	data in	real

Pin Outputs

Pin	Name	Description	Signal Type
2	DataOut	data out	int

Notes/Equations

- This model is used to implement channel decoding of one code block for HS-DSCH. Each firing, ($CodeBlockSize$) DataOut tokens are generated while ($3 \times CodeBlockSize + 12$) DataIn tokens consumed.
- The TransBlockSize parameter determines the transport block size of HS-DSCH. The largest transport block size is 27,952 bits, which corresponds to the highest data rate of 13.976 Mb/s (27,952 bits/2 ms = 13.976 Mb/s). This data rate is obtained by using 16 QAM, an effective code rate of 0.9714, and 15 HS-PDSCHs. The CodeBlockSize is calculated according to section 4.2.2.2 in [1], with $X_i = TransBlockSize$.
- The schematic of Turbo coder in 3GPP is a parallel concatenated convolutional code (PCCC). A iterative Turbo decoder using modified BAHL et al. algorithm [2][3] is used in this model. The iterative number can be set from 1 through 10 using parameter setting.

References

1. 3GPP Technical Specification TS 25.212, "Multiplexing and channel coding (FDD)," Version 6.7.0, Dec. 2005.
2. L.R. Bahl, J. Cocke, F. Jeinek and J. Raviv. "Optimal decoding of linear codes for minimizing symbol error rate." IEEE Trans. Inform. Theory, vol. IT-20. pp.248-287, March 1974.
3. C. Berrou and A. Glavieus. "Near optimum error correcting coding and decoding: turbo-codes", IEEE Trans. Comm., pp. 1261-1271, Oct. 1996.

HSDPA_ChEncoder

HSDPA channel encoder

Symbol

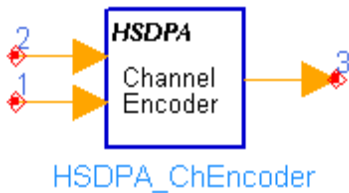

Description: Code block segmentation and turbo encoder

Library: HSDPA, Multiplexers & Coders

Class: SDFHSDPA_ChEncoder

Derived From: HSDPA_DSCH_Base

Parameters

Name	Description	Default	Type	Range
UE_Category	: Category_1, Category_2, Category_3, Category_4, Category_5, Category_6, Category_7, Category_8, Category_9, Category_10, Category_11, Category_12	Category_1	enum	
TransBlockSize	Transport block size	3202	int	[1, max transport block size] †

† Refer to the [FDD E-DCH physical layer categories](#) in the [HSUPA Design Library](#) documentation.

Pin Inputs

Pin	Name	Description	Signal Type
1	CQI	channel quality indicator	int
2	DataIn	data in	int

Pin Outputs

Pin	Name	Description	Signal Type
3	DataOut	data out	int

Notes/Equations

1. This model is used to implement code block segmentation and channel coding for HS-DSCH as defined in 4.5.3 in [1]. There will be a maximum of one transport block. The rate 1/3 turbo coding shall be used. Each firing, ($BlockNum \times BlockSize$) DataOut tokens are generated while ($N_{data} + 24$) DataIn tokens consumed. If CQI pin is connected and has input tokens, $Ndata=N_TransBlockSize$. $N_TransBlockSize$ is the maximum transport block size, which the UE of specific category can support according to Table 7 of 6A.2 in [2]. If CQI pin is unconnected, $Ndata=TransBlockSize$, where $TransBlockSize$ is a parameter of this model. The $BlockNum$ and $BlockSize$ are calculated according to section 4.2.2.2 in [1], with $X_i = N_{data}$.
2. The $TransBlockSize$ parameter determines the transport block size of HS-DSCH. The largest transport block size is 27,952 bits, which corresponds to the highest data rate of 13.976 Mb/s (27,952 bits/2 ms = 13.976 Mb/s). This data rate is obtained by using 16 QAM, an effective code rate of 0.9714, and 15 HS-PDSCHs.
3. The input pin CQI is optional. If connected, the input value of CQI should be in the range of 1 to 30.

References

1. 3GPP Technical Specification TS 25.212, "Multiplexing and channel coding (FDD)," Version 6.7.0, Dec. 2005.
2. 3GPP Technical Specification TS 25.214, "Physical layer procedures (FDD)," Version 6.7.1, Dec. 2005.

HSDPA_ChEstimate

Path Parameter Estimate Aided by Pilot Symbols

Symbol

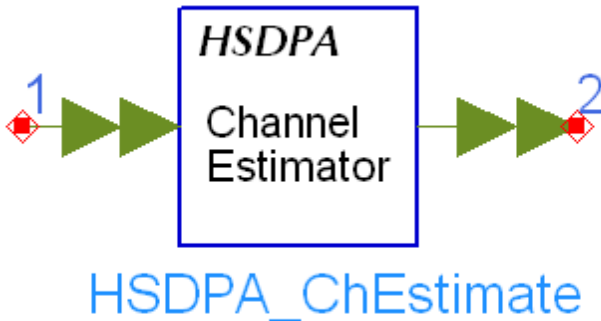

Description: Path parameter estimate aided by pilot symbols
 Library: HSDPA, Receiver
 Class: SDFHSDPA_ChEstimate
 Derived From: HSDPA_RakeBase

Parameters

Name	Description	Default	Sym	Type	Range
TXDiversity	transmit diversity in downlink: No_Diversity, STTD	No_Diversity		enum	
PathNum	number of paths or fingers of Rake	6	L	int	[1, 16]

Pin Inputs

Pin	Name	Description	Signal Type
1	SymCH1	despread signals of the first code channel in downlink,	multiple complex

Pin Outputs

Pin	Name	Description	Signal Type
2	CHEst	estimation of path parameter of current slot	multiple complex

	based on	
--	----------	--

Notes/Equations

1. This model is used to estimate path characteristics aided by pilot symbols of CPICH in downlink. Each firing, N tokens are consumed at SymCH per each port, and N tokens are produced at CHEst per each port, where N is the symbol number CPICH in downlink per TTI, and N is the symbol number of CPICH per TTI. The number of ports for SymCH and CHEst depends on the PathNum.

References

1. 3GPP Technical Specification TS25.211 V6.7.0, "Physical channels and mapping of transport channels onto physical channels (FDD)," Dec. 2005.
2. S.Tanaka, M.Sawahashi, and F.Adachi, "Pilot Symbol-Assisted Decision-Directed Coherent Adaptive Array Diversity for DS-CDMA Mobile Radio Reverse Link," Proc. Wireless'97, Canada, July 1997.
3. Y.Honda, K.Jamal, "Channel Estimation based on Time-Multiplexed Pilot Symbols," IEICE Technical Report RCS96-70, August 1996.

HSDPA_CodeBlkDeseg

Code block desegmentation

Symbol

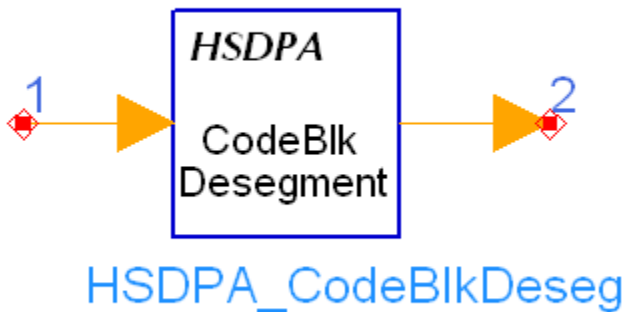

Advanced Design System 2008

Description: Code block desegmentation
Library: HSDPA, Demultiplexers & Decoders
Class: SDFHSDPA_CodeBlkDeseg
Derived From: HSDPA_DSCH_Base

Parameters

Name	Description	Default	Type	Range
TransBlockSize	Transport block size	3202	int	[1, max transport block size] †

† Refer to the [FDD E-DCH physical layer categories](#) in the [HSUPA Design Library](#) documentation.

Pin Inputs

Pin	Name	Description	Signal Type
1	DataIn	data in	int

Pin Outputs

Pin	Name	Description	Signal Type
2	DataOut	data out	int

Notes/Equations

1. This model is used to implement code block desegmentation.
Each firing, the tokens of all code blocks within one TTI are consumed at pin DataIn, while TransBlockSize + 24 tokens are generated at pin DataOut.
2. This model performs the inverse operation of code block segmentation to combine all transport blocks within one TTI.

References

1. 3GPP Technical Specification TS 25.212, "Multiplexing and channel coding (FDD)," Version 6.7.0, Dec. 2005.

HSDPA_CRCDecoder

HSDPA CRC decoder

Symbol

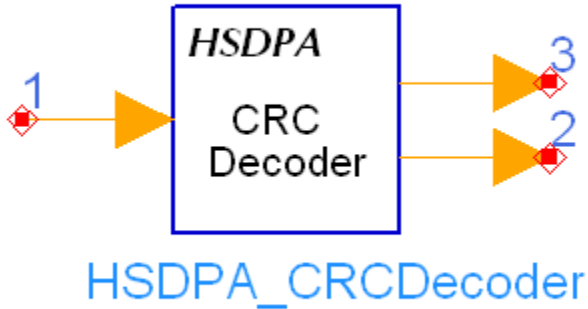

Description: CRC decoder
 Library: HSDPA, Demultiplexers & Decoders
 Class: SDFHSDPA_CRCDecoder
 Derived From: HSDPA_DSCH_Base

Parameters

Name	Description	Default	Type	Range
TransBlockSize	Transport block size	3202	int	[1, max transport block size] †
Polynomial	generator polynomial	0x1800063	int	[3, ∞)

† Refer to the [FDD E-DCH physical layer categories](#) in the [HSUPA Design Library](#) documentation.

Pin Inputs

Pin	Name	Description	Signal Type
1	DataIn	data in	int

Pin Outputs

Pin	Name	Description	Signal Type
-----	------	-------------	-------------

2	CRCOut	data out	int
3	DataOut	data out	int

Notes/Equations

1. This model is used to implement CRC check for each transport block in HS-DSCH. The calculation of the CRC parity bits is referenced in [Reference\[1\]](#).
Each firing, TransBlockSize DataOut tokens are generated while (TransBlockSize+24) DataIn tokens and 1 CRCOut token consumed.
2. The TransBlockSize parameter determines the transport block size of HS-DSCH. The largest transport block size is 27,952 bits, which corresponds to the highest data rate of 13.976 Mb/s (27,952 bits/2 ms = 13.976 Mb/s). This data rate is obtained by using 16 QAM, an effective code rate of 0.9714, and 15 HS-PDSCHs.
3. The cyclic generator polynomial for HS-DSCH is: $g_{CRC24}(D) = D^{24} + D^{23} + D^6 + D^5 + D + 1$, and the hex representation of polynomial is 0x1800063.

References

1. 3GPP Technical Specification TS 25.212, "Multiplexing and channel coding (FDD)," Version 6.7.0, Dec. 2005.

HSDPA_CRCEncoder

HSDPA CRC Encoder

Symbol

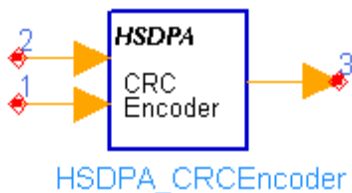

Description: Add CRC to each Transport Block
 Library: HSDPA, Multiplexers & Coders
 Class: SDFHSDPA_CRCEncoder
 Derived From: HSDPA_DSCH_Base

Parameters

Name	Description	Default	Type	Range
UE_Category	: Category_1, Category_2, Category_3, Category_4, Category_5, Category_6, Category_7, Category_8, Category_9, Category_10, Category_11, Category_12	Category_1	enum	
TransBlockSize	Transport block size	3202	int	[1, max transport block size] †
Polynomial	generator polynomial	0x1800063	int	[3, ∞)

† Refer to the [FDD E-DCH physical layer categories](#) in the [HSUPA Design Library](#) documentation.

Pin Inputs

Pin	Name	Description	Signal Type
1	CQI	channel quality indicator	int
2	DataIn	data in	int

Pin Outputs

Pin	Name	Description	Signal Type
3	DataOut	data out	int

Notes/Equations

1. This model is used to implement CRC attachment on HS-DSCH as defined in 4.5.1 in [1]. Each firing, (Ndata+24) DataOut tokens are generated while Ndata DataIn tokens consumed. If CQI pin is connected and has input tokens, Ndata=N_TransBlockSize. N_TransBlockSize is the maximum transport block size, which the UE of specific category can support according to Table 7 of 6A.2 in [2]. If CQI pin is unconnected, Ndata=TransBlockSize, where TransBlockSize is a parameter of this model.
2. The input pin CQI is optional. If connected, the input value of CQI should be in the range of 1 to 30.
3. The TransBlockSize parameter determines the transport block size of HS-DSCH. The largest transport block size is 27,952 bits, which corresponds to the highest data rate of 13.976 Mb/s (27,952 bits/2 ms = 13.976 Mb/s).

This data rate is obtained by using 16 QAM, an effective code rate of 0.9714, and 15 HS-PDSCHs.

4. The cyclic generator polynomial for HS-DSCH is: $g_{CRC24}(D) = D^{24} + D^{23} + D^6 + D^5 + D + 1$, and the hex representation of polynomial is 0x1800063.

References

1. 3GPP Technical Specification TS 25.212, "Multiplexing and channel coding (FDD)," Version 6.7.0, Dec. 2005.
2. 3GPP Technical Specification TS 25.214, "Physical layer procedures (FDD)," Version 6.7.1, Dec. 2005.

HSDPA_Deinterleaver

Interleaver

Symbol

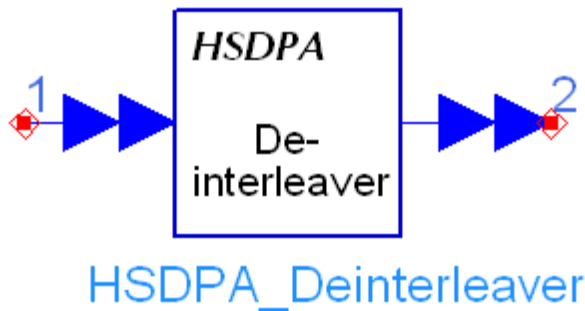

Description: Deinterleaver
 Library: HSDPA, Demultiplexers & Decoders
 Class: SDFHSDPA_Deinterleaver

Parameters

Name	Description	Default	Type
------	-------------	---------	------

Advanced Design System 2008

MS	Modulation scheme: _QPSK, _16QAM	_QPSK	enum
NumHSPDSCH	Number of HS_PDSCH	5	int

Pin Inputs

Pin	Name	Description	Signal Type
1	DataInM	data in	multiple real

Pin Outputs

Pin	Name	Description	Signal Type
2	DataOutM	data out	multiple real

Notes/Equations

- This model is used to implement deinterleaving on HS-DSCH. Each firing, 1920 tokens are consumed at each sub-port of pin DataInM, while 1920 tokens are generated at each sub-port of pin DataOutM.
- NumHSPDSCH specifies the number of HS-PDSCHs to be processed and each HS-PDSCH occupies one sub-port of pin DataInM and one sub-port of pin DataOutM. MS specifies the modulation scheme of each HS-PDSCH.
- Deinterleaving is the inverse operation of interleaving defined in 4.5.6 of [Reference \[1\]](#). The bits of each HS-PDSCH input to the deinterleaver at each firing are denoted by $u_{p,1}, u_{p,2}, u_{p,3}, \dots, u_{p,1920}$, wherein p is the index of HS-PDSCHs. The basic deinterleaver is a block deinterleaver of fixed size 960, which performs the inverse operation of basic interleaver described in 4.2.11 of [Reference \[1\]](#). For QPSK, the first 960 bits $u_{p,1}, u_{p,2}, u_{p,3}, \dots, u_{p,960}$ are processed by the basic deinterleaver, and the deinterleaved 960 bits are padded 960 0s as the output of corresponding sub-port of pin DataOutM at each firing. For 16QAM, two identical basic deinterleavers are used. $u_{p,1}, u_{p,2}, u_{p,3}, \dots, u_{p,1920}$ are divided two by two between the deinterleavers: bits $u_{p,k}, u_{p,k+1}$ go to the first basic deinterleaver and $u_{p,k+2}, u_{p,k+3}$ go to the second basic deinterleaver. Bits are collected two by two from the deinterleavers: $v_{p,k}, v_{p,k+1}$ are obtained from the first basic deinterleaver and $v_{p,k+2}, v_{p,k+3}$ are obtained from the second basic deinterleaver.

References

- 3GPP Technical Specification TS 25.212, "Multiplexing and channel coding (FDD)," Version 6.7.0, Dec. 2005.

HSDPA_Despread

De-Spread Chip Sequence of Code Channels

Symbol

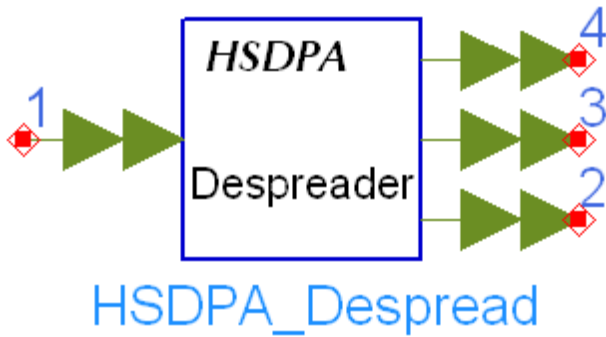

Description: De-spread chip sequence of code channels
 Library: HSDPA, Receiver
 Class: SDFHSDPA_Despread
 Derived From: HSDPA_RakeBase

Parameters

Name	Description	Default	Sym	Type	Range
PathNum	number of paths or fingers of Rake	6	L	int	[1, 16]
ScrambleCode	Index of scramble code	0		int	
NumHSPDSCH	number of HS-PDSCHs	5	M	int	[1, 16]
HS_PDSCH_CodeOffset	Spread code offset	1		int	

Pin Inputs

Advanced Design System 2008

Pin	Name	Description	Signal Type
1	ChpSeq	chip sequences of optimum multi-path	multiple complex

Pin Outputs

Pin	Name	Description	Signal Type
2	HSPDSCHSym	de-spread signals of all code channels of current slot	multiple complex
3	HSSCCHSym	de-spread signals HSSCCH Channel in downlink	multiple complex
4	PilotSym	de-spread signals of Common in downlink	multiple complex

Notes/Equations

- This model is used to despread the resolved multiple path signals from HSDPA_DownSample. Each firing, N tokens are consumed at ChipSeq per each port, where N is the number of chips per TTI. The port number of ChipSeq depends on PathNum. M tokens are produced at HSPDSCHSym per each port, where M is the number of symbols per TTI in all HS-PDSCHs. P tokens are produced at HSSCCHSym per each port, where P is the number of symbols per TTI in HS-SCCH. Q tokens are produced at PilotSym per each port, where Q is the number of symbols per TTI in CPICH. The port number of HSPDSCHSym, HSSCCHSym and PilotSym all depends on PathNum.
One TTI delay is inserted to spread code to keep the synchronization with ChipSeq.

References

- 3GPP Technical Specification TS25.211 V6.7.0, "Physical channels and mapping of transport channels onto physical channels (FDD)," Dec. 2005.
- 3GPP Technical Specification TS25.213 V6.4.0, "Spreading and modulation (FDD)," Sept. 2005.
- A. J. Viterbi, "CDMA: Principles of Spread Spectrum Communication," Wesley Publishing Company, 1995.

HSDPA_DL_Rake

Rake Receiver

Symbol

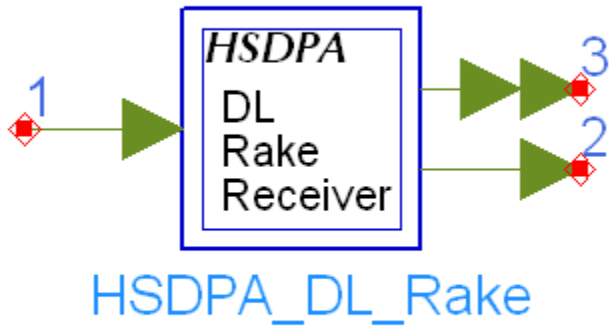

Description: Rake receiver
 Library: HSDPA, Receiver
 Class: SDFHSDPA_DL_Rake

Parameters

Name	Description	Default	Sym	Type	Range
TXDiversity	transmit diversity in downlink: No_Diversity, DL_STTD	No_Diversity		enum	
SampleRate	number of samples per chip	4	S	int	[1, 32]
PathNum	number of paths or fingers of Rake	6	L	int	[1, 16]
MaxDelay	maximum path delay in terms of chips	40	D	int	[PathNum, number of half chips of one slot]
ScrambleCode	Index of scramble code	0		int	
NumHSPDSCH	number of DPCHs	5	M	int	[1, 15]
HS_PDSCH_CodeOffset	spread code offset	1		int	

Advanced Design System 2008

Pin Inputs

Pin	Name	Description	Signal Type
1	SmpSig	received baseband complex envelope signal samples	complex

Pin Outputs

Pin	Name	Description	Signal Type
2	HS_SCCH	combined signals of the HS_SCCH	complex
3	HS_PDSCH	combined signals of the HS_PDSCH	multiple complex

Notes/Equations

- This subnetwork is used to implement coherent Rake receiver with maximal ratio combining (MRC) on multiple code channels. Each firing, $S \times T$ tokens are consumed at SmpSig, where T is the number of chips per TTI, S is the number of SamplesPerChip. $N1$ tokens are produced at HS-PDSCH, where $N1$ is the number of HS-PDSCH symbols per TTI. $N2$ tokens are produced at HS-SCCH, where $N2$ is the number of HS-SCCH symbols per TTI. The outputs at HS-PDSCH and HS-SCCH are delayed by one TTI because of Rake receiver signal processing.
- The schematic for this subnetwork is shown below.

HSDPA_DL_RakeReceiver Schematic



References

- 3GPP Technical Specification TS25.211 V6.7.0, "Physical channels and mapping of transport channels onto

physical channels (FDD)," Dec. 1999.

2. 3GPP Technical Specification TS25.213 V6.4.0,"Spreading and modulation (FDD)," Sept. 2005.

3. A. J. Viterbi, "CDMA: Principles of Spread Spectrum Communication," Wesley Publishing Company, 1995.

HSDPA_DL_Receiver

HSDPA downlink receiver

Symbol

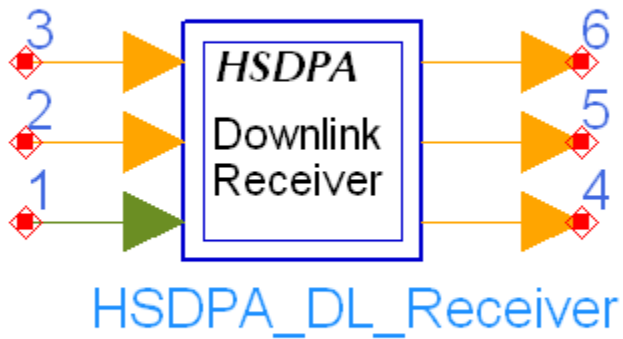

Description: HSDPA receiver

Library: HSDPA, Receiver

Class: SDFHSDPA_DL_Receiver

Parameters

Name	Description	Default	Type	Range
SamplesPerChip	number of samples per chip	4	int	[1, 32]
PathNum	number of paths or fingers of Rake	6	int	[1, 16]

Advanced Design System 2008

MaxDelaySample	maximum path delay in terms of chips	40	int	[PathNum, number of half chips of one slot]
HS_PDSCH_FRC	Fixed reference channel: H-Set_1, H-Set_2, H-Set_3, H-Set_4, H-Set_5, H-Set_6	H-Set_1	enum	
UEIdentity	UE identity (16 bits)	0xAAAA	int	[0, 66535]
SignalingSource	: SCCH, External	External	enum	
MS	Modulation scheme: _QPSK, _16QAM	_QPSK	enum	
HS_PDSCH_CodeOffset	Spread code offset	1	int	
TC_Iteration	Turbo code decoder iteration number	4	int	[1, 10]
TTIPattern	inter-TTI pattern	{1, 0, 0, 1, 0, 0}	int array	[0, 1]

Pin Inputs

Pin	Name	Description	Signal Type
1	inCHip	received baseband complex envelope signal samples	complex
2	RV	redundancy version	int
3	nd	new data indicator	int

Pin Outputs

Pin	Name	Description	Signal Type
4	SCCHCRC	SCCH CRC result	int
5	PDSCH	PDSCH dtat	int
6	PDSCHCRC	PDSCH CRC result	int

Notes/Equations

1. This subnetwork model is used to demodulate and decode HSDPA related downlink signals, i.e., HS-DSCH and HS-SCCH. The schematic for this subnetwork is shown below.

HSDPA_DL_Receiver Schematic

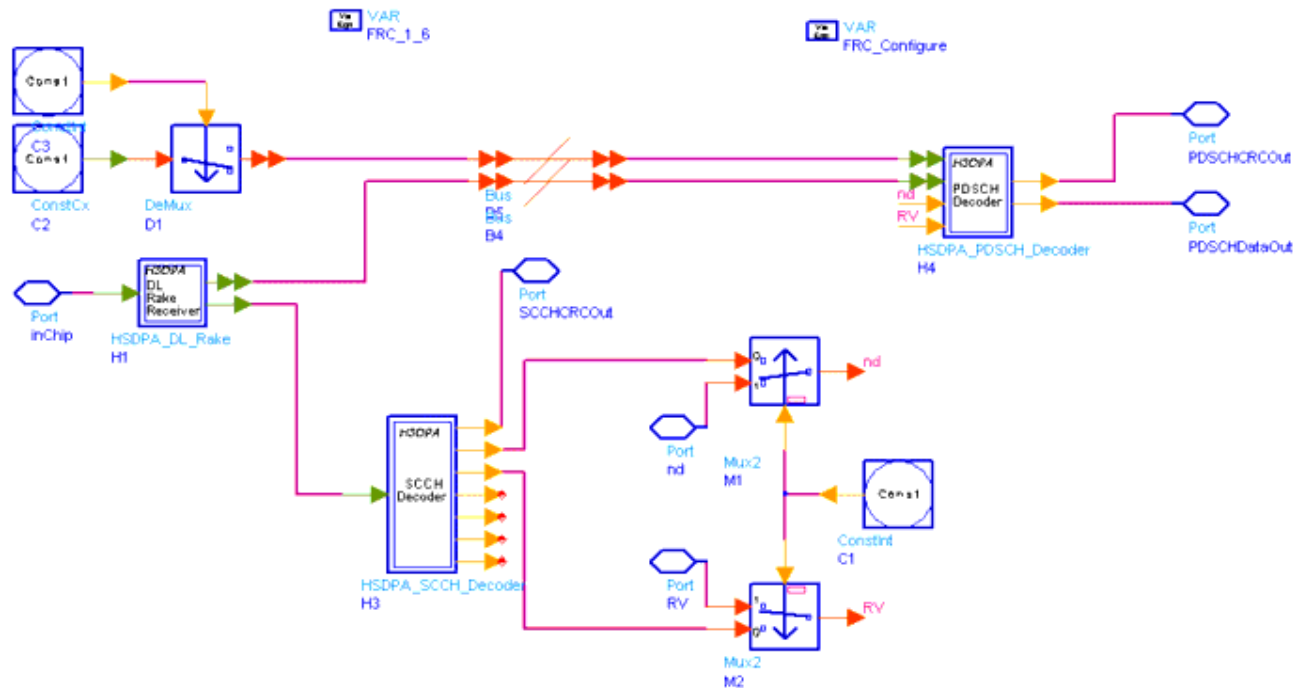

2. To despread and demodulate a CDMA signal, the channel information and path delay information must be determined. Errors in channel estimation and path search deteriorate the receiver performance.
3. The path searching is performed by correlating the received signals with the spreading code specified in a window whose size is set by MaxDelaySample. The correlations at different offsets are ranked; the top ones are assumed to be the offsets where the paths could occur.
4. All paths are combined assuming that all paths are useful for improving the decoding reliability. In some cases, paths with low SNR are actually harmful to the final SNR improvement. The user must set PathNum for better decoding performance in multipath conditions.
5. There is one slot delay associated with the decoded information.
6. For more information regarding the Rake receiver and different channel decoders, see [HSDPA DL Rake](#), [HSDPA PDSCH Decoder](#), and [HSDPA SCCH Decoder](#) respectively.

References

1. 3GPP Technical Specification TS 25.211, "Physical channels and mapping of transport channels onto physical channels (FDD)," Version 6.7.0, Dec. 2005.
2. 3GPP Technical Specification TS 25.212, "Multiplexing and channel coding (FDD)," Version 6.7.0, Dec. 2005.
3. 3GPP Technical Specification TS 25.213, "Spreading and modulation (FDD)," Version 6.4.0, Sept. 2005.

HSDPA_DL_ReceiverRF

HSDPA downlink RF receiver

Symbol

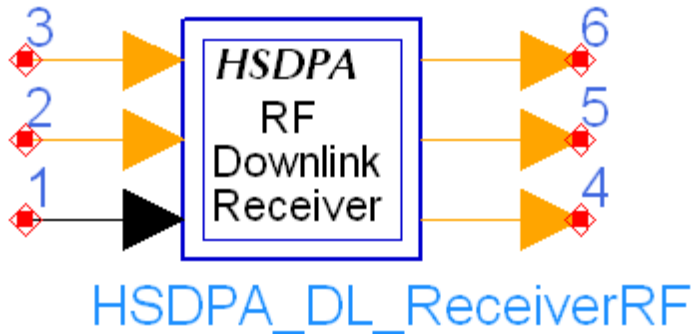

Description: HSDPA receiver

Library: HSDPA, Receiver

Class: TSDFHSDPA_DL_ReceiverRF

Parameters

Name	Description	Default	Unit	Type	Range
FCarrier	Carrier frequency	2140 MHz	Hz	real	(0, ∞)
RIn	Input resistance	50	Ohm	real	(0, ∞)
Phase	Reference phase in degrees	0.0	deg	real	($-\infty$, ∞)
RRC_FilterLength	RRC filter length (chips)	16		int	[2, 128]
ExcessBW	Excess bandwidth of raised cosine filters	0.22		real	(0.0, 1.0)
SamplesPerChip	number of samples per chip	4		int	[1, 32]
PathNum	number of paths or fingers of Rake	6		int	[1, 16]

Advanced Design System 2008

MaxDelaySample	maximum path delay in terms of chips	40		int	[PathNum, number of half chips of one slot]
HS_PDSCH_FRC	Fixed reference channel: H-Set_1, H-Set_2, H-Set_3, H-Set_4, H-Set_5, H-Set_6	H-Set_1		enum	
UEIdentity	UE identity (16 bits)	0xAAAA		int	[0, 66535]
SignalingSource	: SCCH, External	External		enum	
MS	Modulation scheme: _QPSK, _16QAM	_QPSK		enum	
HS_PDSCH_CodeOffset	Spread code offset	1		int	
TC_Iteration	Turbo code decoder iteration number	4		int	[1, 10]
TTIPattern	inter-TTI pattern	{1, 0, 0, 1, 0, 0}		int array	[0, 1]

Pin Inputs

Pin	Name	Description	Signal Type
1	RFin	input RF signal	timed
2	RV	redundancy version	int
3	nd	new data indicator	int

Pin Outputs

Pin	Name	Description	Signal Type
4	SCCHCRC	SCCH CRC result	int
5	PDSCH	PDSCH dtat	int
6	PDSCHCRC	PDSCH CRC result	int

Notes/Equations

1. This subnetwork model is used to demodulate and decode HSDPA related downlink RF signals, i.e., HS-DSCH and HS-SCCH. The schematic for this subnetwork is shown below.

HSDPA_DL_ReceiverRF Schematic

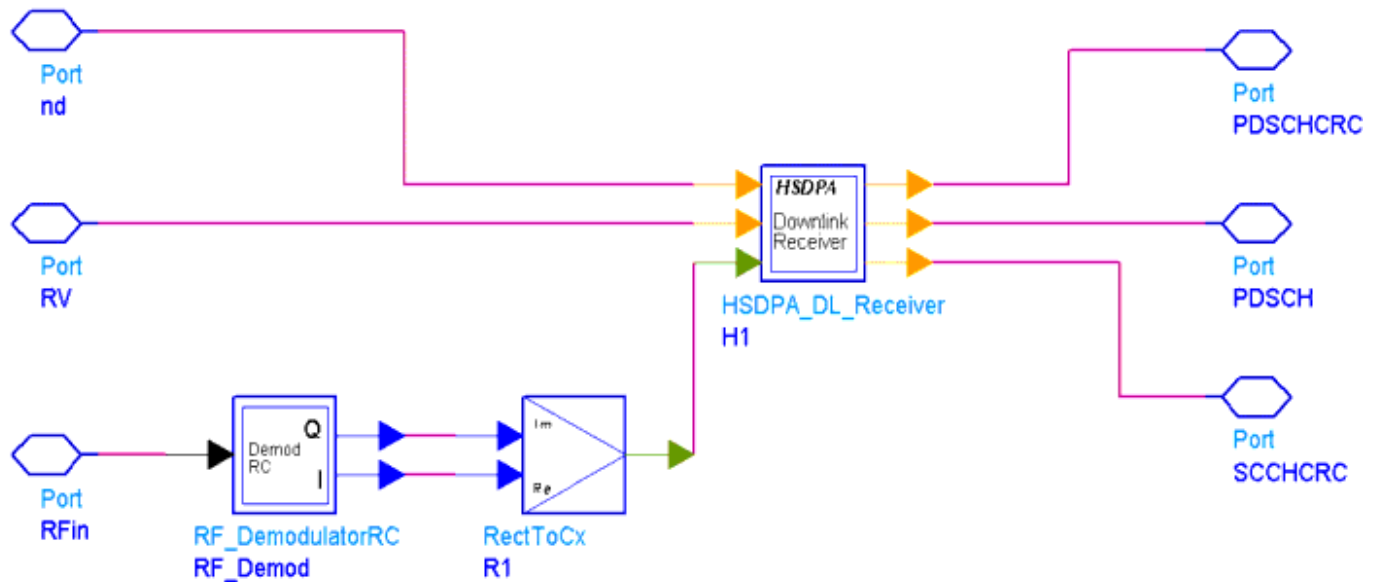

2. To despread and demodulate a CDMA signal, the channel information and path delay information must be determined. Errors in channel estimation and path search deteriorate the receiver performance.
3. The path searching is performed by correlating the received signals with the spreading code specified in a window whose size is set by MaxDelaySample. The correlations at different offsets are ranked; the top ones are assumed to be the offsets where the paths could occur.
4. All paths are combined assuming that all paths are useful for improving the decoding reliability. In some cases, paths with low SNR are actually harmful to the final SNR improvement. The user must set PathNum for better decoding performance in multipath conditions.
5. There is one slot delay associated with the decoded information.
6. For more information regarding the Rake receiver and different channel decoders, see [HSDPA_DL_Rake](#), [HSDPA_PDSCH_Decoder](#), and [HSDPA_SCCH_Decoder](#) respectively.

References

1. 3GPP Technical Specification TS 25.211, "Physical channels and mapping of transport channels onto physical channels (FDD)," Version 6.7.0, Dec. 2005.
2. 3GPP Technical Specification TS 25.212, "Multiplexing and channel coding (FDD)," Version 6.7.0, Dec. 2005.
3. 3GPP Technical Specification TS 25.213, "Spreading and modulation (FDD)," Version 6.4.0, Sept. 2005.

HSDPA_DL_Source

HSDPA downlink source

Symbol

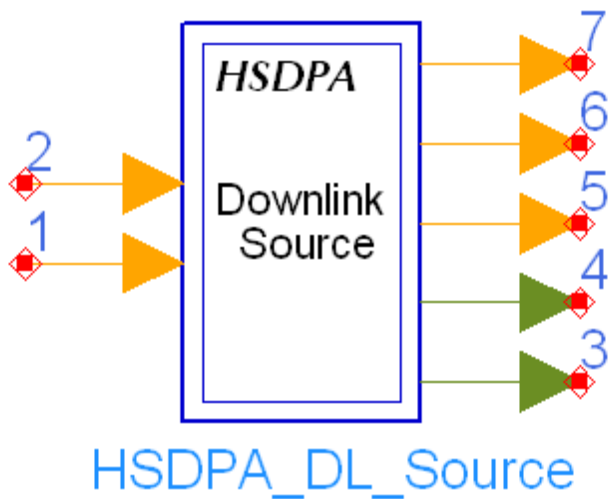

Description: HSDPA downlink source

Library: HSDPA, Signal Sources

Class: SDFHSDPA_DL_Source

Parameters

Name	Description	Default	Unit	Type	Range
OutputSTTD	Whether or not export STTD: NO, YES	NO		enum	
DPCH_Configured	Setting to YES if DPCH is configured, otherwise NO: NO, YES	NO		enum	
DPCH_EcToIor	DPCH power gain	-15	dB	real	$(-\infty, \infty)$

Advanced Design System 2008

	factor				
PCPICH_EcToIor	Primary CPICH power gain in dB	-10.0	dB	real	$(-\infty, \infty)$
PCCPCH_EcToIor	PCCPCH power gain in dB	-12	dB	real	$(-\infty, \infty)$
SCH_EcToIor	SCH power gain in dB	-15	dB	real	$(-\infty, \infty)$
PICH_EcToIor	PICH power gain in dB	-15	dB	real	$(-\infty, \infty)$
HS_SCCH_Configure	Whether or not SCCH 1 to 4 configured	{1, 0, 0, 0}		int array	
HS_SCCH_EcToIor	Power gain factor of HS-SCCH 1 to 4 in dB	{-10, -10, -10, -10}	dB	real array	
HS_PDSCH_Configure	Whether or not HS-PDSCH 1 to 4 configured	{1, 0, 0, 0}		int array	
HS_PDSCH_EcToIor	Power gain factor of HS-PDSCH 1 to 4 in dB	{-6, -6, -6, -6}	dB	real array	
HS_PDSCH_UE_Cate	UE category of HS-PDSCH 1 to 4	{0, 0, 0, 0}		int array	
HS_PDSCH_UEIdent	UE identity of HS-PDSCH 1 to 4	{0xAAAA, 0x12AA, 0x1AAA, 0x1FAA}		int array	[0, 66535]
HS_PDSCH_MS	Modulation scheme of HS-PDSCH 1 to 4	{0, 0, 0, 0}		int array	
HS_PDSCH_CodeOff	Spread code offset of HS-PDSCH 1 to 4	{1, 13, 14, 15}		int array	
HS_PDSCH_1_FRC	Fixed reference channel of HS-PDSCH 1: H-Set_1, H-Set_2, H-Set_3, H-Set_4, H-Set_5, H-Set_6	H-Set_1		enum	

Advanced Design System 2008

HS_PDSCH_1_RVSeq	RV coding sequence of of HS-PDSCH 1	{0, 2, 5, 6}		int array	
HS_PDSCH_1_DataPattern	Data pattern of HS-PDSCH 1: Random, PN9, PN15, Repeat Bits	Random		enum	
HS_PDSCH_1_RepeatingDataValue	Repeating data value of HS-PDSCH 1	0x0001		int	[0, 65535]
HS_PDSCH_1_RepeatingDataPeriod	Repeating data period of HS-PDSCH 1	2		int	[1, 16]
HS_PDSCH_1_TTIPattern	TTI pattern of HS-PDSCH 1	{1, 0, 0, 1, 0, 0}		int array	[0, 1]
HS_PDSCH_2_TTIPattern	TTI pattern of HS-PDSCH 2	{1, 0, 0, 1, 0, 0}		int array	[0, 1]
HS_PDSCH_3_TTIPattern	TTI pattern of HS-PDSCH 3	{1, 0, 0, 1, 0, 0}		int array	[0, 1]
HS_PDSCH_4_TTIPattern	TTI pattern of HS-PDSCH 4	{1, 0, 0, 1, 0, 0}		int array	[0, 1]
HS_PDSCH_2_NumberOfPhysicalChannels	Number of physical channels of HS-PDSCH 2	1		int	
HS_PDSCH_3_NumberOfPhysicalChannels	Number of physical channels of HS-PDSCH 3	1		int	
HS_PDSCH_4_NumberOfPhysicalChannels	Number of physical channels of HS-PDSCH 4	1		int	

Pin Inputs

Pin	Name	Description	Signal Type
1	CQI	channel quality indicator	int
2	ARQ	automatic repeat request	int

Pin Outputs

Pin	Name	Description	Signal Type
-----	------	-------------	-------------

Advanced Design System 2008

3	DataOut	data out	complex
4	STTDOut	data out	complex
5	RV	redundancy version	int
6	nd	new data indicator	int
7	BitDSCH	DSCH bit	int

Notes/Equations

1. This subnetwork model is used to simulate integrated HSDPA base station signal source.
The schematic for this subnetwork is shown below.

HSDPA_DL_Source Schematic

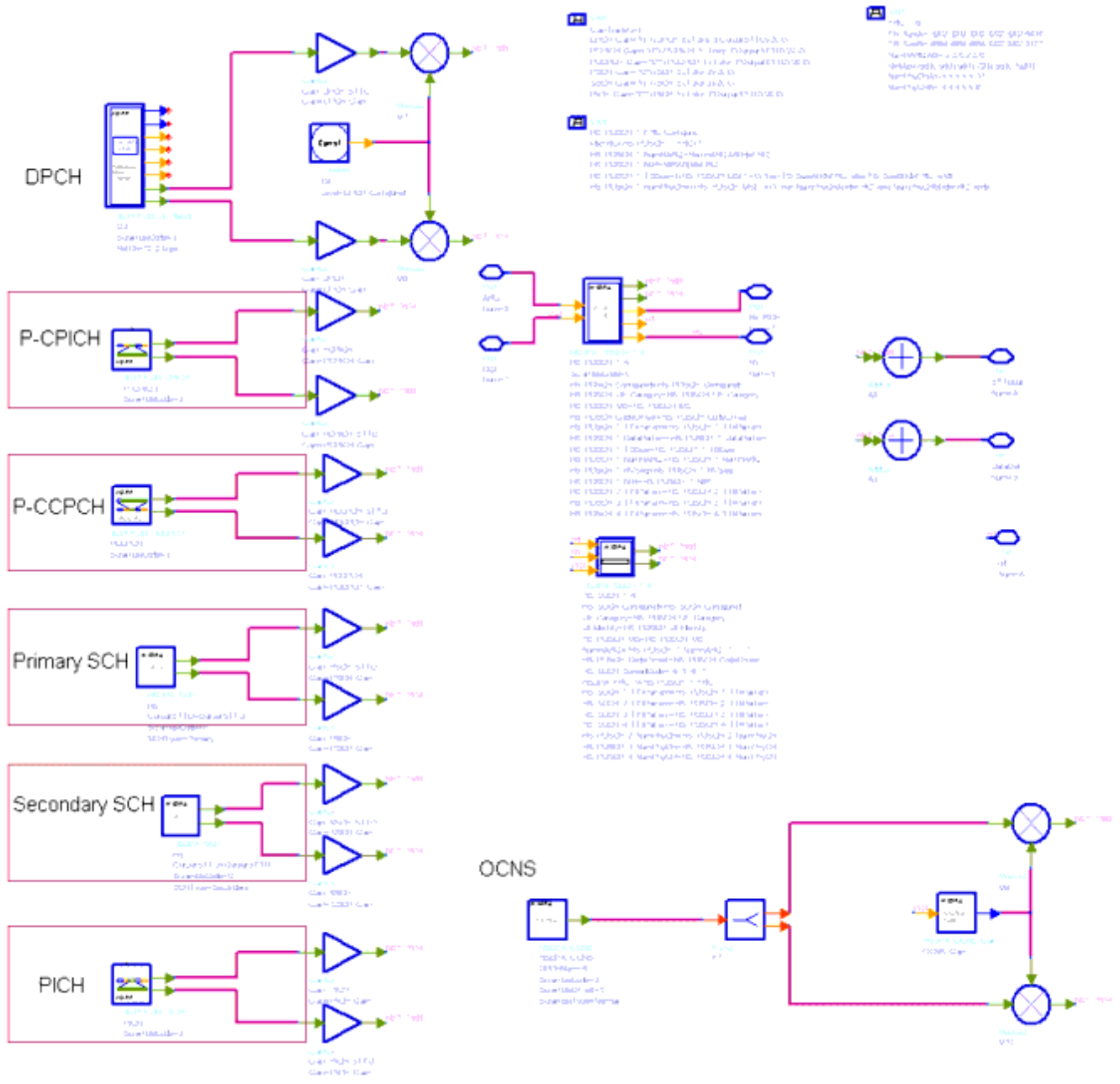

2. The physical channels integrated in this subnetwork model are listed in the table below.

Downlink Physical Channels	
Physical Channel	
P_CPICH	
S_CPICH	
PCPCH	

P_SCH
S_SCH
SCCPCH
PICH
DPCH
HS-PDSCH
HS-SCCH
OCNS

3. The HS-PDSCH is generated by the composite HSDPA_PDSCH_1_4 which can support one full coded and three uncoded HS-PDSCH sources.
4. The HS-SCCH is generated by the full coded HSDPA_SCCH_1_4 which can support four full coded HS-SCCH sources.
5. The DPCH is generated by the fully-coded 3GPPFDD_DL_RefCh signal source.
6. Four data patterns are supported: random, PN9, PN15, and repeated.
7. If data is from a user-defined file, the file name is defined by the respective UserFileName. The user can edit the file with any text editor. The separator between bits can be a space, comma, or any other separator. If the bit sequence is shorter than the output length, data will be output repeatedly.
8. The DPCH data rate can be set through RefCh. DPCH channelization code is set through DPCH_SpreadCode.
9. CPICH includes primary and secondary CPICH. Primary CPICH channelization code is fixed at C256,0. CPICH_SpreadCode is set on secondary CPICH, with a spread factor of 256.
10. The PICH spread factor is 256. PICH channelization code is set through PICH_SpreadCode.
11. The PCPCH channelization code is fixed at C256,1. The SCCPCH spread factor and spread channelization code are set through SCCPCH_SpreadFactor and SCCPCH_SpreadCode.
12. Relative gain factor of each channel can be set through the respective GainFactor parameters. They are multiplied to the output of each channel model. A channel can be disabled by setting its gain factor to 0.
13. It is suggested that the square of all the GainFactors add up to 1 to make sure the RMS value of output downlink signal is 1. However, it isn't so important for baseband signal. A normalized downlink source can be implemented by HSDPA_DL_SourceRF.
14. OCNS can be set through the OCNS_ChannelNum and six OCNS array parameters. The default OCNS channel is 16 and corresponding array parameters are 16 elements long. To change the OCNS channel number, the corresponding array parameters must be changed. For details regarding OCNS settings, refer to [HSDPA_OCNS_Gain](#).

References

1. 3GPP Technical Specification TS 25.211, "Physical channels and mapping of transport channels onto physical channels (FDD)," Version 6.7.0, Dec. 2005.
2. 3GPP Technical Specification TS 25.212, "Multiplexing and channel coding (FDD)," Version 6.7.0, Dec. 2005.
3. 3GPP Technical Specification TS 25.213, "Spreading and modulation (FDD)," Version 6.4.0, Sept. 2005.
4. 3GPP Technical Specification TS 25.214, "Physical layer procedures (FDD)," Version 6.7.1, Dec. 2005.

HSDPA_DL_SourceRF

HSDPA downlink RF signal source

Symbol

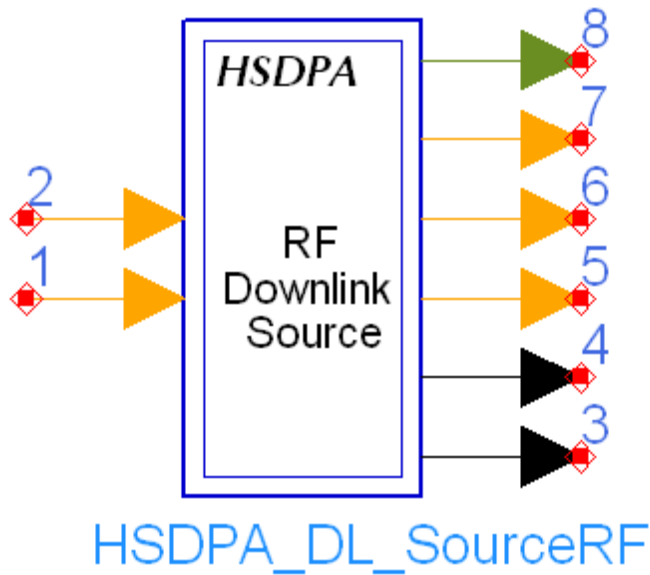

Description: HSDPA downlink RF signal source

Library: HSDPA, Signal Sources

Class: TSDFHSDPA_DL_SourceRF

Parameters

Name	Description	Default	Unit	Type	Range
ROut	Output resistance	DefaultROut	Ohm	real	(0, ∞)
FCarrier	Carrier frequency	2140 MHz	Hz	real	(0, ∞)
Power	RF output power	0.01	W	real	[0, ∞)
PhasePolarity	If set to Invert, Q channel signal is inverted: DL_Normal,	DL_Normal		enum	

Advanced Design System 2008

	DL_Invert				
GainImbalance	Gain imbalance, I to Q channel, in dB	0.0		real	$(-\infty, \infty)$
PhaseImbalance	Phase imbalance, I to Q channel, in degrees	0.0		real	$(-\infty, \infty)$
I_OriginOffset	I origin offset in percent with respect to output rms voltage	0.0		real	$(-\infty, \infty)$
Q_OriginOffset	Q origin offset in percent with respect to output rms voltage	0.0		real	$(-\infty, \infty)$
IQ_Rotation	IQ rotation in degrees	0.0		real	$(-\infty, \infty)$
NDensity	Additive noise density in dBm per Hz	-10000		real	$(-\infty, \infty)$
SamplesPerChip	Samples per chip	4		int	[2, 32]
ExcessBW	Excess bandwidth of raised cosine filters	0.22		real	(0.0, 1.0)
RRC_FilterLength	Length of raised cosine filters in number of symbols	16		int	[2, 128]
SourceType	Signal source type: HSDPA, TestModel1_16DPCHs, TestModel1_32DPCHs, TestModel1_64DPCHs, TestModel2, TestModel3_16DPCHs, TestModel3_32DPCHs, TestModel4, TestModel5_6DPCHs, TestModel5_14DPCHs, TestModel5_30DPCHs	HSDPA		enum	
OutputSTTD	Whether or not export STTD: NO, YES	NO		enum	

Advanced Design System 2008

DPCH_Configured	Setting to YES if DPCH is configured, otherwise NO: NO, YES	NO		enum	
DPCH_EcToIor	DPCH power gain factor	-15	dB	real	$(-\infty, \infty)$
PCPICH_EcToIor	Primary CPICH power gain in dB	-10.0	dB	real	$(-\infty, \infty)$
PCCPCH_EcToIor	PCCPCH power gain in dB	-12	dB	real	$(-\infty, \infty)$
SCH_EcToIor	SCH power gain in dB	-15	dB	real	$(-\infty, \infty)$
PICH_EcToIor	PICH power gain in dB	-15	dB	real	$(-\infty, \infty)$
HS_SCCH_Configured	Whether or not SCCH 1 to 4 configured	{1, 0, 0, 0}		int array	
HS_SCCH_EcToIor	Power gain factor of HS-SCCH 1 to 4 in dB	{-10, -10, -10, -10}	dB	real array	
HS_PDSCH_Configured	Whether or not HS-PDSCH 1 to 4 configured	{1, 0, 0, 0}		int array	
HS_PDSCH_EcToIor	Power gain factor of HS-PDSCH 1 to 4 in dB	{-6, -6, -6, -6}	dB	real array	
HS_PDSCH_UE_Category	UE category of HS-PDSCH 1 to 4	{1, 1, 1, 1}		int array	
HS_PDSCH_UE_Identity	UE identity of HS-PDSCH 1 to 4	{0xAAAA, 0x12AA, 0x1AAA, 0x1FAA}		int array	[0, 66535]
HS_PDSCH_MS	Modulation scheme of HS-PDSCH 1 to 4	{0, 0, 0, 0}		int array	
HS_PDSCH_CodeOffset	Spread code offset of HS-PDSCH 1 to 4	{1, 13, 14, 15}		int array	
HS_PDSCH_1_FRC	Fixed reference channel of HS-PDSCH 1:	H-Set_1		enum	

Advanced Design System 2008

	H-Set_1, H-Set_2, H-Set_3, H-Set_4, H-Set_5, H-Set_6				
HS_PDSCH_1_RVSeq	RV coding sequence of of HS-PDSCH 1	{0, 2, 5, 6}		int array	
HS_PDSCH_1_DataPattern	Pattern of HS-PDSCH 1: Random, PN9, PN15, Repeat Bits	Random		enum	
HS_PDSCH_1_RepetitionDataValue	Repeating data value of HS-PDSCH 1	0x0001		int	[0, 65535]
HS_PDSCH_1_RepetitionPeriod	Repeating data period of HS-PDSCH 1	2		int	[1, 16]
HS_PDSCH_1_TTIPattern	TTI pattern of HS-PDSCH 1	{1, 0, 0, 1, 0, 0}		int array	[0, 1]
HS_PDSCH_2_TTIPattern	TTI pattern of HS-PDSCH 2	{1, 0, 0, 1, 0, 0}		int array	[0, 1]
HS_PDSCH_3_TTIPattern	TTI pattern of HS-PDSCH 3	{1, 0, 0, 1, 0, 0}		int array	[0, 1]
HS_PDSCH_4_TTIPattern	TTI pattern of HS-PDSCH 4	{1, 0, 0, 1, 0, 0}		int array	[0, 1]
HS_PDSCH_2_NumberOfPhysicalChannels	Number of physical channels of HS-PDSCH 2	1		int	
HS_PDSCH_3_NumberOfPhysicalChannels	Number of physical channels of HS-PDSCH 3	1		int	
HS_PDSCH_4_NumberOfPhysicalChannels	Number of physical channels of HS-PDSCH 4	1		int	
TM_OutputMode	output mode of test model: Ramp, Stable	Ramp		enum	
TM4_EnableP_CPICT	Test Model 4 enable primary	YES		enum	

Advanced Design System 2008

	CPICH? NO, YES				
TM4_PCCPCH_SCH_Gain	Test Model 4 PCCPCH_SCH level setting	-6	dB	real	$(-\infty, \infty)$
TM4_P_CPICH_Gain	Test Model 4 P_CPICH level setting	-6	dB	real	$(-\infty, \infty)$

Pin Inputs

Pin	Name	Description	Signal Type
1	CQI	channel quality indicator	int
2	ARQ	automatic repeat request	int

Pin Outputs

Pin	Name	Description	Signal Type
3	RFout	output RF signal	timed
4	STTDOut	data out	timed
5	RV	redundancy version	int
6	nd	new data indicator	int
7	BitDSCH	DSCH bit	int
8	EVMRef	reference signal for EVM	complex

Notes/Equations

1. This subnetwork model is used to simulate integrated HSDPA base station RF signal source. The schematic for this subnetwork is shown below.

HSDPA_DL_SourceRF Schematic

PICH
DPCH
HS-PDSCH
HS-SCCH
OCNS

3. The HS-PDSCH is generated by the composite HSDPA_PDSCH_1_4 which can support one full coded and three uncoded HS-PDSCH source.
4. The HS-SCCH is generated by the full coded HSDPA_SCCH_1_4 which can support four full coded HS-SCCH source.
5. The DPCH is generated by the fully-coded 3GPPFDD_DL_RefCh signal source.
6. Four data patterns are supported: random, PN9, PN15, and repeated.
7. If data is from a user-defined file, the file name is defined by the respective UserFileName. The user can edit the file with any text editor. The separator between bits can be a space, comma, or any other separator. If the bit sequence is shorter than the output length, data will be output repeatedly.
8. The DPCH data rate can be set through RefCh. DPCH channelization code is set through DPCH_SpreadCode.
9. CPICH includes primary and secondary CPICH. Primary CPICH channelization code is fixed at C256,0. CPICH_SpreadCode is set on secondary CPICH, with a spread factor of 256.
10. The PICH spread factor is 256. PICH channelization code is set through PICH_SpreadCode.
11. The PCPCH channelization code is fixed at C256,1. The SCPCH spread factor and spread channelization code are set through SCPCH_SpreadFactor and SCPCH_SpreadCode.
12. The transmitter power is set by the parameter Power.
Relative power levels of each channel can then be set through the respective GainFactor parameters, in dB units. OCNS_GainFactor is calculated from other GainFactors. (Refer to Table C.6 in [Reference \[5\]](#)).
The GainFactors are converted into voltage values and multiplied to the output of each channel model. A channel can be disabled by setting its gain factor to a large minus value such as -300 dB.
13. OCNS can be set through the OCNS_ChannelNum and six OCNS array parameters. The default OCNS channel is 16 and corresponding array parameters are 16 elements long. To change the OCNS channel number, the corresponding array parameters must be changed. The output of OCNS must be normalized. For details regarding OCNS settings, see [HSDPA_OCNS_Gain](#).

References

1. 3GPP Technical Specification TS 25.211, "Physical channels and mapping of transport channels onto physical channels (FDD)," Version 6.7.0, Dec. 2005.
2. 3GPP Technical Specification TS 25.212, "Multiplexing and channel coding (FDD)," Version 6.7.0, Dec. 2005.
3. 3GPP Technical Specification TS 25.213, "Spreading and modulation (FDD)," Version 6.4.0, Sept. 2005.
4. 3GPP Technical Specification TS 25.214, "Physical layer procedures (FDD)," Version 6.7.1, Dec. 2005.
5. 3GPP Technical Specification TS 25.101, "UE Radio transmission and Reception (FDD)," Version 6.10.0, Dec. 2005.

HSDPA_DownSample

Extract Optimum Samples According to Path Delay Timing

Symbol

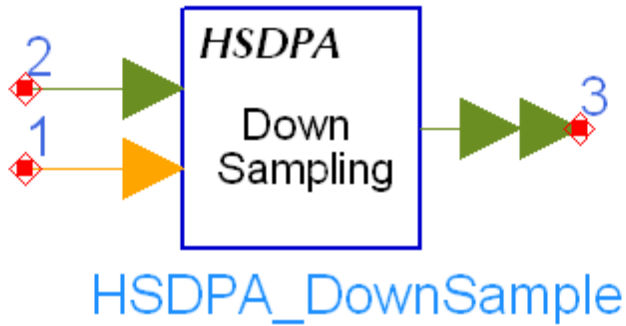

Description: Extract optimum samples according to path delay timing

Library: HSDPA, Receiver

Class: SDFHSDPA_DownSample

Derived From: HSDPA_RakeBase

Parameters

Name	Description	Default	Sym	Type	Range
SampleRate	number of samples per chip	4	S	int	[1, 32]
PathNum	number of paths or fingers of Rake	6	L	int	[1, 16]

Pin Inputs

Pin	Name	Description	Signal Type
1	Delays	path delays in terms of samples	int
2	SmpSig	received baseband complex envelope signal samples	complex

Pin Outputs

Pin	Name	Description	Signal Type
3	ChpSeq	extracted optimum chip sequence	multiple complex

Notes/Equations

1. This model is used to extract optimum samples using the path delay timing given by HSDPA_PathSearch. Each firing, $S \times N$ tokens are consumed at SmpSig, L tokens are consumed at Delays, N tokens are produced at ChipSeq per each port, where N is the number of chips per TTI, S is the SampleRate, and L is the number of path. The port number of ChipSeq depends on PathNum.

References

1. 3GPP Technical Specification TS25.211 V6.7.0, "Physical channels and mapping of transport channels onto physical channels (FDD)," Dec. 2005.
2. A. J. Viterbi, "CDMA: Principles of Spread Spectrum Communication," Wesley Publishing Company, 1995.

HSDPA_EVM

HSDPA EVM measurement

Symbol

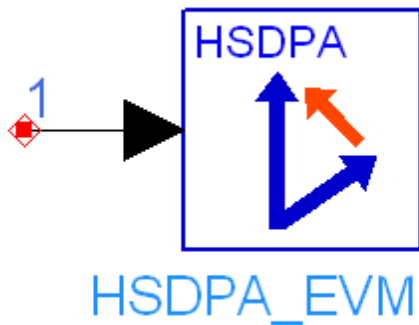

Description: HSDPA EVM measurement
 Library: HSDPA, Measurement
 Class: TSDF_HSDPA_EVM

Parameters

Name	Description	Default	Unit	Type	Range
RLoad	load resistance. DefaultRLoad will inherit from the DF controller.	DefaultRLoad	Ohm	real	(0, ∞)
RTemp	physical temperature, in degrees C, of load resistance. DefaultRTemp will inherit from the DF controller.	DefaultRTemp	Celsius	real	[-273.15, ∞)
FCarrier	carrier frequency	1.9 GHz	Hz	real	(0, ∞)
SymbolRate	symbol rate	3840000	Hz	real	
AnalysisCodeLevel	specifies the channel level that Channel EVM will be calculated for	2		int	[2, 9]
AnalysisCodeIndex	specifies the channel index that Channel EVM	0		int	[0, 2^AnalysisCodeLevel-1]

Advanced Design System 2008

	with be calculated for				
ScrambleCode	index of scramble code	0		int	[0, 511]
ScrambleOffset	scramble code offset	0		int	[0, 15]
ScrambleType	scramble code type: normal, right, left	normal		enum	
syncModeSelection	Sync mode selection: CPICH, SCH, CPICH2	SCH		enum	
TestModel	test model selection: NONE, MODEL_1_DPCH_16, MODEL_1_DPCH_32, MODEL_1_DPCH_64, MODEL_2, MODEL_3_DPCH_16, MODEL_3_DPCH_32, MODEL_4, MODEL_1_DPCH_16_SCCPCH, MODEL_1_DPCH_32_SCCPCH, MODEL_1_DPCH_64_SCCPCH, MODEL_2_SCCPCH, MODEL_3_DPCH_16_SCCPCH, MODEL_3_DPCH_32_SCCPCH, MODEL_4_PCICH, MODEL_5_HSPDSCH_2_DPCH_6, MODEL_5_HSPDSCH_4_DPCH_14, MODEL_5_HSPDSCH_8_DPCH_30	NONE		enum	
MirrorSpectrum	Mirror spectrum about carrier? NO, YES	NO		enum	
EVMIncludeIQOffsets	selection of calculating EVM pre-compensating for IQ origin offset: NO, YES	NO		enum	
SuppressSCH	suppress SCH for channel measurements: NO, YES	NO		enum	
EVMIncludingSCH	boolean if true	NO		enum	

Advanced Design System 2008

	will include the SCH bits when calculating composite EVM: NO, YES				
Start	start time for data recording. DefaultTimeStart will inherit from the DF Controller.	DefaultTimeStart	sec	real	[0, ∞)
ResultLength	result length in number of slots	15		int	[15, ∞)
MeasurementOffset	specifies the offset in number of slots from the start of the data record to analysis of channel EVM	0		int	[0, ∞)
MeasurementInterval	specifies how many slots that channel EVM will be calculated over	1		int	[1, ∞)
alpha	specify the alpha for 3GPP root raised cosine filtering.	0.22		real	[0, 1]

Pin Inputs

Pin	Name	Description	Signal Type
1	input	input signal	timed

Notes/Equations

1. This subnetwork model is used to measure EVM for 3GPP HSDPA transmitter as defined in [Reference \[1\]](#). Additionally, it can be used to measure EVM of a specific channel. The input signal must be a timed RF (complex envelope) signal. The schematic for this subnetwork is shown below.

HSDPA_EVM Schematic

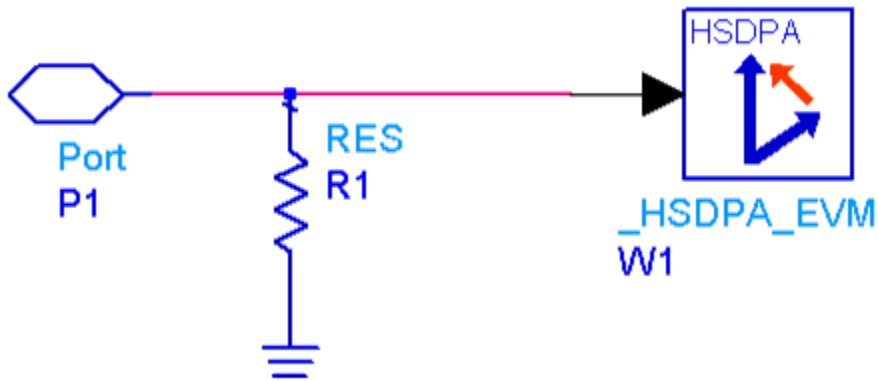

2. The Error Vector Magnitude is a measure of the difference between the reference waveform and the measured waveform. This difference is called the error vector. Both waveforms pass through a matched Root Raised Cosine filter with bandwidth 3.84 MHz and roll-off=0.22. Both waveforms are then further modified by selecting the frequency, absolute phase, absolute amplitude, and chip clock timing so as to minimize the error vector.
3. The Error Vector Magnitude shall not be worse than 17.5% when the base station is transmitting a composite signal using only QPSK modulation. The Error Vector Magnitude shall not be worse than 12.5% when the base station is transmitting a composite signal that includes 16QAM modulation.
4. The AnalysisCodeLevel parameter specifies the channel level that Channel EVM will be calculated for. The AnalysisCodeIndex parameter specifies the channel index that Channel EVM will be calculated for.
5. If ScrambleType is normal, the scramble code index is equal to ScrambleCode \times 16 + ScrambleOffset. If ScrambleType is right, the index is ScrambleCode \times 16 + ScrambleOffset + 16384. If ScrambleType is left, the index is ScrambleCode \times 16 + ScrambleOffset + 8192.
6. The syncModeSelection parameter specifies synchronization mode: CPICH, SCH or CPICH2.
7. The TestModel parameter is used to select the base station test models as defined in [Reference \[2\]](#). If TestModel is selected to be none, the transmitter outputs the user defined HSDPA downlink signal.
8. Starting at the time instant specified by the Start parameter, a signal segment of ResultLength slots is acquired. This signal segment is searched in order for a complete frame to be detected.
9. If the acquired signal segment does not contain 15 slots, the algorithm may fail to detect any frame and the analysis that follows will most likely produce incorrect results. Therefore, ResultLength must be longer than 15. If there is an unknown idle part at the beginning of the burst, then a TimedSink component can be used to plot the signal in the data display. By observing the magnitude of the signal's envelope versus time one can determine the duration of the burst and the idle interval. Making the Start parameter equals to the idle interval will facilitate the testing.
10. The MirrorSpectrum parameter can be used to mirror the spectrum (invert the Q envelope) at the output of the modulator. Depending on the configuration of the mixers in the upconverter, which typically follows a modulator, the signal at the upconverter's input may need to be mirrored. If such a configuration is used, then this parameter should be set to YES.
11. The EVMIncludeIQOffset parameter specifies whether to pre-compensate for IQ origin offset or not when calculating EVM.
12. The SuppressSCH parameter specifies whether to suppress SCH for channel EVM measurements or not.
13. The EVMIncludingSCH parameter specifies whether to suppress SCH for composite EVM measurements or not.
14. The MeasurementOffset parameter specifies the offset in number of slots from the start of the data record to analysis of channel EVM. The MeasurementInterval parameter specifies how many slots that channel EVM will be calculated over.
15. The alpha parameter specifies the alpha for 3GPP root raised cosine filtering and should be 0.22 in this testing.

References

1. 3GPP Technical Specification TS 25.104, "Base Station (BS) radio transmission and reception (FDD)," Version 6.11.0, Dec. 2005.
2. 3GPP Technical Specification TS 25.141, "Base station (BS) conformance testing (FDD)," V6.12.0, Dec. 2005.

HSDPA_Interleaver

Interleaver

Symbol



Description: Interleaver

Library: HSDPA, Multiplexers & Coders

Class: SDFHSDPA_Interleaver

Parameters

Name	Description	Default	Type
UE_Category	: Category_1, Category_2, Category_3, Category_4, Category_5, Category_6, Category_7, Category_8, Category_9, Category_10, Category_11, Category_12	Category_1	enum
MS	Modulation scheme: _QPSK, _16QAM	_QPSK	enum
NumHSPDSCH	Number of HS_PDSCH	5	int

Pin Inputs

Pin	Name	Description	Signal Type
-----	------	-------------	-------------

Advanced Design System 2008

1	CQI	channel quality indicator	int
2	DataIn	data in	int

Pin Outputs

Pin	Name	Description	Signal Type
3	DataOut	data out	int

Notes/Equations

- This model is used to implement interleaving on HS-DSCH defined in 4.5.6 of [Reference \[1\]](#). Each firing, $1920 \times \text{MaxNumHSPDSCH}$ tokens are consumed at pin DataIn, and 1 token is consumed at pin CQI if it is connected, while $1920 \times \text{MaxNumHSPDSCH}$ tokens are generated at pin DataOut. $1920 \times \text{MaxNumHSPDSCH}$ is the possible maximum data bits and MaxNumHSPDSCH is the possible maximum HS-PDSCHs within one TTI. If pin CQI is connected, MaxNumHSPDSCH equals to maximum HS-PDSCHs UE_Category supports. Otherwise, MaxNumHSPDSCH equals to NumHSPDSCH.
- If pin CQI is connected, modulation scheme and number of HS-PDSCHs practically used (EffectiveNumHSPDSCH) are determined by input CQI value and UE_Category according to Table 7 of 6A.2 in [Reference \[2\]](#). Otherwise, modulation schemes are determined by MS, and EffectiveNumHSPDSCH is equal to NumHSPDSCH.
- Although $1920 \times \text{MaxNumHSPDSCH}$ tokens are consumed at each firing, only the first EffectiveNumHSPDSCH HS-PDSCHs are occupied and 0s are padded for the other HS-PDSCHs. Each HS-PDSCH contains 1920 bits. If the modulation scheme is QPSK, only the first 960 bits are useful data bits, and the other 960 bits are 0s. If the modulation scheme is 16QAM, all 1920 bits are useful data bits.
- The bits input to the interleaver are denoted by $u_{p,1}, u_{p,2}, u_{p,3}, \dots, u_{p,1920}$, wherein p is the index of HS-PDSCHs. The basic interleaver is a block interleaver of fixed size 960, which is described in 4.2.11 of [Reference \[1\]](#). For QPSK, the useful data bits $u_{p,1}, u_{p,2}, u_{p,3}, \dots, u_{p,960}$ are interleaved by the basic interleaver, and the interleaved 960 bits are padded 960 0s as the output. For 16QAM, two identical basic interleavers are used. $u_{p,1}, u_{p,2}, u_{p,3}, \dots, u_{p,1920}$ are divided two by two between the interleavers: bits $u_{p,k}, u_{p,k+1}$ go to the first basic interleaver and $u_{p,k+2}, u_{p,k+3}$ go to the second basic interleaver. Bits are collected two by two from the interleavers: $v_{p,k}, v_{p,k+1}$ are obtained from the first basic interleaver and $v_{p,k+2}, v_{p,k+3}$ are obtained from the second basic interleaver.

References

- 3GPP Technical Specification TS 25.212, "Multiplexing and channel coding (FDD)," Version 6.7.0, Dec. 2005.
- 3GPP Technical Specification TS 25.214, "Physical layer procedures (FDD)," Version 6.7.1, Dec. 2005.

HSDPA_OCNS_Gain

HSDPA OCNS gain

Symbol

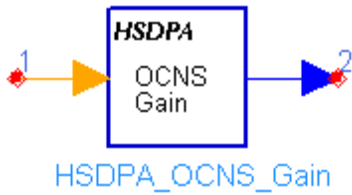

Description: HSDPA OCNS gain calculator
 Library: HSDPA, Multiplexers & Coders
 Class: SDFHSDPA_OCNS_Gain

Parameters

Name	Description	Default	Unit	Type	Range
OutputSTTD	Output STTD mode option: NO, YES	NO		enum	
HS_PDSCH_UE_Category	UE category	1 1 1 1		int array	
PCPICH_Power_EcToI	Primary CPICH power gain in dB	-10.0	dB	real	$(-\infty, \infty)$
PCCPCH_Power_EcToI	PCPCH power gain in dB	-12.0	dB	real	$(-\infty, \infty)$
SCH_Power_EcToI	SCH power gain in dB	-15.0	dB	real	$(-\infty, \infty)$
PICH_Power_EcToI	PICH power gain in dB	-15.0	dB	real	$(-\infty, \infty)$
DPCH_Configured	Setting to YES if DPCH is configured, otherwise NO: NO, YES	NO		enum	
DPCH_Power_EcToI	DPCH power gain in dB	-15.0	dB	real	$(-\infty, \infty)$
HS_SCCH_Configured	HS-SCCH configured flags	1 0 0 0		int array	

Advanced Design System 2008

HS_SCCH_EcToIor	HS-SCCH power gain in dB	-9 -9 -9 -9	dB	real array	
HS_PDSCH_Config	HS-PDSCH configured flags	1 0 0 0		int array	
HS_PDSCH_EcToIor	HS-PDSCH power gain in dB	-10 -10 -10 -10	dB	real array	
HS_PDSCH_1_TTIpattern	TTI pattern	1 1 1 1 1 1		int array	[0, 1]
HS_PDSCH_2_TTIpattern	TTI pattern	1 1 1 1 1 1		int array	[0, 1]
HS_PDSCH_3_TTIpattern	TTI pattern	1 1 1 1 1 1		int array	[0, 1]
HS_PDSCH_4_TTIpattern	TTI pattern	1 1 1 1 1 1		int array	[0, 1]

Pin Inputs

Pin	Name	Description	Signal Type
1	CQI	channel quality indicator	int

Pin Outputs

Pin	Name	Description	Signal Type
2	GainOut	Gain for OCNS group	real

Notes/Equations

1. This model is used to calculate OCNS gain so that total transmit power spectral density of Node B(Ior) adds to one. OCNS interference consists of six dedicated data channels as specified in table C.13 of [Reference \[3\]](#). Each firing, 7680 GainOut tokens are generated for one TTI.
2. The input pin CQI is optional. If connected, the input value of CQI should be in the range of 1 to 30. The CQI value is used to determine the reference power adjustment according to section 6A.2 of [Reference \[2\]](#).

References

1. 3GPP Technical Specification TS 25.212, "Multiplexing and channel coding (FDD)," Version 6.7.0, Dec. 2005.
2. 3GPP Technical Specification TS 25.214, "Physical layer procedures (FDD)," Version 6.7.1, Dec. 2005.
3. 3GPP Technical Specification TS 25.101, "User Equipment (UE) radio transmission and reception (FDD)," Version 6.10.0, Dec. 2005.

HSDPA_PathSearch

Multiple Path Timing Search

Symbol

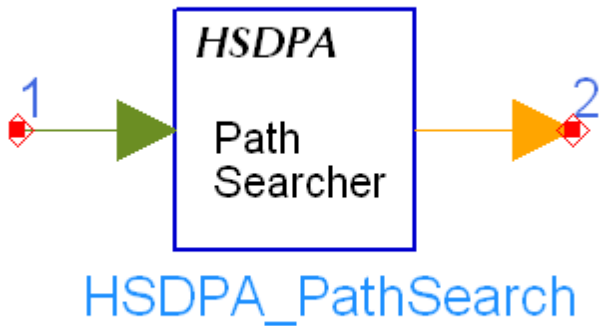

Description: Multiple path maximum power timing search

Library: HSDPA, Receiver

Class: SDFHSDPA_PathSearch

Derived From: HSDPA_RakeBase

Parameters

Name	Description	Default	Sym	Type	Range
TXDiversity	transmit diversity in downlink: No_Diversity, STTD	No_Diversity		enum	
SampleRate	number of samples per chip	4	S	int	[1, 32]
PathNum	number of paths or fingers of Rake	6	L	int	[1, 16]
MaxDelay	maximum path delay in terms of chips	40	D	int	[PathNum, number of half chips of one slot]

Advanced Design System 2008

ScrambleCode	Index of scramble code	0		int	
--------------	------------------------	---	--	-----	--

Pin Inputs

Pin	Name	Description	Signal Type
1	SmpSig	received baseband complex envelope signal samples	complex

Pin Outputs

Pin	Name	Description	Signal Type
2	Delays	searched timing of path delay in terms of samples	int

Notes/Equations

1. This model is used to search and determine the timing of multiple paths. Each path timing corresponds to one propagation path of radio.
Each firing, $S \times T$ tokens are consumed at SmpSig, where T is the number of chips per TTI and S is the number of SamplesPerChip. L tokens are produced at Delays, L is the number of PathNum. The output at Delays is delayed by one TTI because signals of multiple path may be overlapped on adjacent slots.

References

1. 3GPP Technical Specification TS25.211 V6.7.0, "Physical channels and mapping of transport channels onto physical channels (FDD)," Dec. 2005.
2. A. J. Viterbi, "CDMA: Principles of Spread Spectrum Communication," Wesley Publishing Company, 1995.
3. S.Fukumoto, M.Sawahashi, F.Adachi, "Matched Filter-Based RAKE Combiner for Wideband DS-CDMA Mobile Radio," IEICE Trans. Commun., Vol., E81-B, No.7, July 1998.

HSDPA_PDSCH_1_4

HSDPA HS-PDSCH Source

Symbol

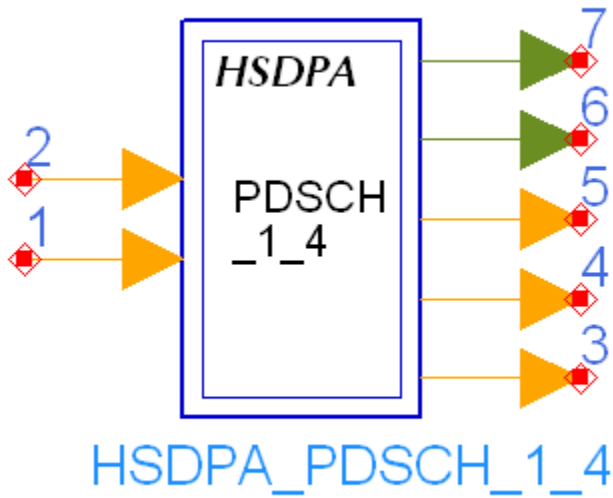

Description: HSDPA HS-PDSCH Source
 Library: HSDPA, Signal Sources
 Class: SDFHSDPA_PDSCH_1_4

Parameters

Name	Description	Default	Unit	Type	Range
ScrambleCode	Index of scramble code	0		int	
HS_PDSCH_Config	Whether or not HS-PDSCH 1 to 4 configured	{1, 1, 1, 1}		int array	
HS_PDSCH_EcToIcr	Power gain factor of of HS-PDSCH 1 to 4 in dB	{-10, -10, -10, -10}	dB	real array	
HS_PDSCH_UE_Cate	UE category of of HS-PDSCH 1 to 4	{1, 1, 1, 1}		int array	
HS_PDSCH_MS	Modulation scheme of HS-PDSCH 1 to 4	{0, 0, 0, 0}		int array	
HS_PDSCH_NumPhy	Number of physical channels HS PDSCH 1 to 4	{5, 1, 1, 1}		int array	
HS_PDSCH_CodeOff	HS-PDSCH offset	{1, 13, 14, 15}		int array	

Advanced Design System 2008

	spread code offset				
HS_PDSCH_1_TTI_Pattern	HS-PDSCH1 TTI pattern of HS-PDSCH 1	{1, 0, 0, 1, 0, 0}		int array	[0, 1]
HS_PDSCH_1_Data_Pattern	HS-PDSCH1 data pattern: Random_1, PN9_1, PN15_1, Repeat Bits_1	Random_1		enum	
HS_PDSCH_1_RepeatingBitValue	HS-PDSCH1 repeating bit value	0x0001		int	[0, 65535]
HS_PDSCH_1_RepeatingBitPeriod	HS-PDSCH1 repeating bit period	2		int	[1, 16]
HS_PDSCH_1_TransportBlockSize	HS-PDSCH1 transport block size	3202		int	[1, max transport block size]†
HS_PDSCH_1_NumberOfHARQProcesses	Number of HARQ processes of HS-PDSCH1	1		int	[1, 6]
HS_PDSCH_1_RVSequence	HS-PDSCH1 redundancy version coding sequence	{0, 2, 5, 6}		int array	[0, 7]
HS_PDSCH_1_NIR	HS-PDSCH1 Incremental Redundancy Register Buffer Size	9600		int	
HS_PDSCH_2_TTI_Pattern	HS-PDSCH2 TTI pattern of HS-PDSCH 2	{1, 0, 0, 1, 0, 0}		int array	[0, 1]
HS_PDSCH_2_Data_Pattern	HS-PDSCH2 data pattern: PN9_2, PN15_2, FIX4_2, _4_1_4_0_2, _8_1_8_0_2, _16_1_16_0_2, _32_1_32_0_2, _64_1_64_0_2	PN9_2		enum	
HS_PDSCH_3_TTI_Pattern	HS-PDSCH3 TTI pattern of HS-PDSCH 3	{1, 0, 0, 1, 0, 0}		int array	[0, 1]
HS_PDSCH_3_Data_Pattern	HS-PDSCH3 data pattern	PN9_3		enum	

Advanced Design System 2008

	pattern: PN9_3, PN15_3, FIX4_3, _4_1_4_0_3, _8_1_8_0_3, _16_1_16_0_3, _32_1_32_0_3, _64_1_64_0_3				
HS_PDSCH_4_TTI_Pattern	TTI pattern of HS-PDSCH 4	{1, 0, 0, 1, 0, 0}		int array	[0, 1]
HS_PDSCH_4_Data_Pattern	HS-PDSCH4 data pattern: PN9_4, PN15_4, FIX4_4, _4_1_4_0_4, _8_1_8_0_4, _16_1_16_0_4, _32_1_32_0_4, _64_1_64_0_4	PN9_4		enum	

† Refer to the [FDD E-DCH physical layer categories](#) in the [HSUPA Design Library](#) documentation.

Pin Inputs

Pin	Name	Description	Signal Type
1	CQI	channel quality indicator	int
2	ARQ	automatic repeat request	int

Pin Outputs

Pin	Name	Description	Signal Type
3	RV	redundancy version	int
4	nd	new data indicator	int
5	BitDSCH	DSCH bit	int
6	DataOut	data out	complex
7	STTDOut	data out	complex

Notes/Equations

1. This subnetwork model is used to simulate the integrated base station signal source. The schematic for this subnetwork is shown below.

HSDPA_PDSCH_1_4 Schematic

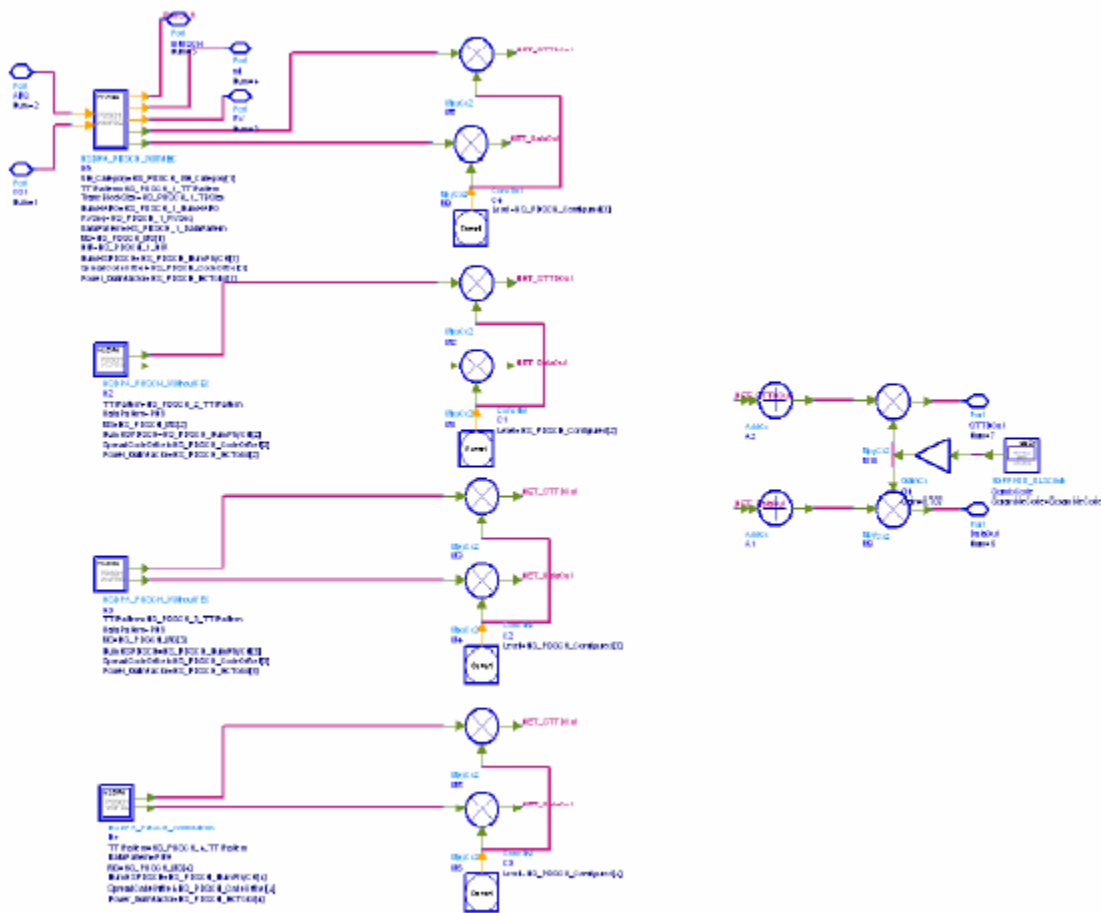

2. The HSDPA_PDSCH_1_4 is generated by one fully-coded [HSDPA_PDSCH_WithFEC](#) signal source and three [HSDPA_PDSCH_WithoutFEC](#) signal sources.

References

1. 3GPP Technical Specification TS 25.211, "Physical channels and mapping of transport channels onto physical channels (FDD)," Version 6.7.0, Dec. 2005.
2. 3GPP Technical Specification TS 25.212, "Multiplexing and channel coding (FDD)," Version 6.7.0, Dec. 2005.
3. 3GPP Technical Specification TS 25.213, "Spreading and modulation (FDD)," Version 6.4.0, Sept. 2005.
4. 3GPP Technical Specification TS 25.214, "Physical layer procedures (FDD)," Version 6.7.1, Dec. 2005.

HSDPA_PDSCH_Decoder

HS-PDSCH channel decoder

Symbol

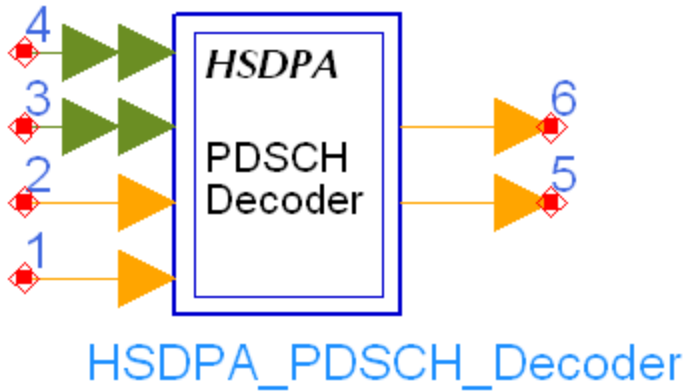

Library: HSDPA, Demultiplexers & Decoders
 Class: SDFHSDPA_PDSCH_Decoder

Parameters

Name	Description	Default	Type	Range
TransBlockSize	Transport block size	3202	int	[1, max transport block size] [†]
MS	Modulation scheme: _QPSK, _16QAM	_QPSK	enum	
NIR		9600	int	
TC_Iteration	Turbo code decoder iteration number	4	int	[1, 10]
NumHSPDSCH	Number of HS_PDSCH	5	int	
NumHARQ	Number of HARQ processes	1	int	[1, 6]
TTIPattern	inter-TTI pattern	{1, 1, 1, 1, 1, 1}	int array	[0, 1]

[†] Refer to the [FDD E-DCH physical layer categories](#) in the [HSUPA Design Library](#) documentation.

Pin Inputs

Pin	Name	Description	Signal Type
1	RV	redundancy version	int
2	nd	new data indicator	int
3	DataInM	data for physical channel(s)	multiple complex
4	STTDInM	data for physical channel(s)	multiple complex

Pin Outputs

Pin	Name	Description	Signal Type
5	DataOut	data out	int
6	CRCOOut	CRC out	int

Notes/Equations

1. This subnetwork model is used to fulfill the inverse process of "Coding for HS-DSCH", which is defined in [Reference \[2\]](#). The schematic for this subnetwork is shown below.

HSDPA_PDSCH_Decoder Schematic

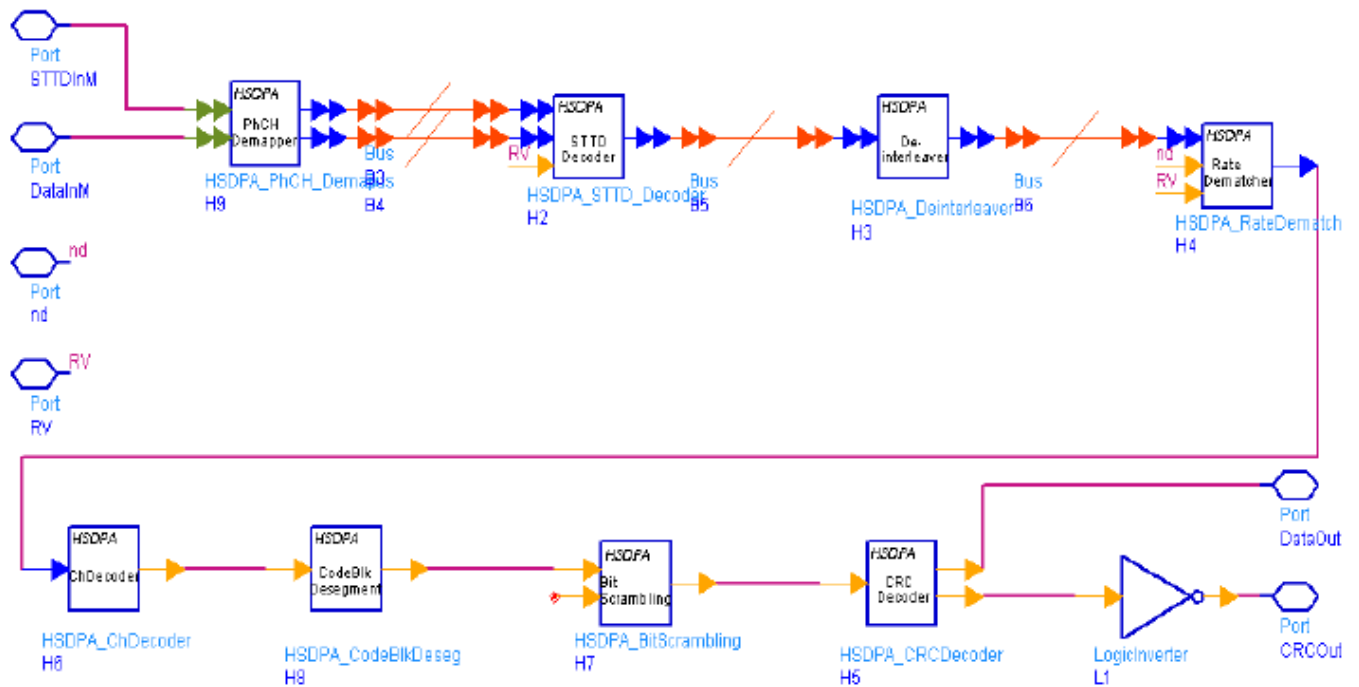

2. This subnetwork model completes the following operations:
 - Physical channel demapping

- STTD decoding
 - De-Interleaving
 - Rate de-matching
 - Channel decoding
 - Code block desegmentation
 - Bit de-scrambling
 - CRC de-attachment
3. For each received HS-DSCH transport block, error-detection is performed by checking the CRC. If there is no error, the pin CRCOut outputs 1 (otherwise outputs 0).

References

1. 3GPP Technical Specification TS 25.211, "Physical channels and mapping of transport channels onto physical channels (FDD)," Version 6.7.0, Dec. 2005.
2. 3GPP Technical Specification TS 25.212, "Multiplexing and channel coding (FDD)," Version 6.7.0, Dec. 2005.
3. 3GPP Technical Specification TS 25.213, "Spreading and modulation (FDD)," Version 6.4.0, Sept. 2005.

HSDPA_PDSCH_WithFEC

HSDPA downlink PDSCH With FEC

Symbol

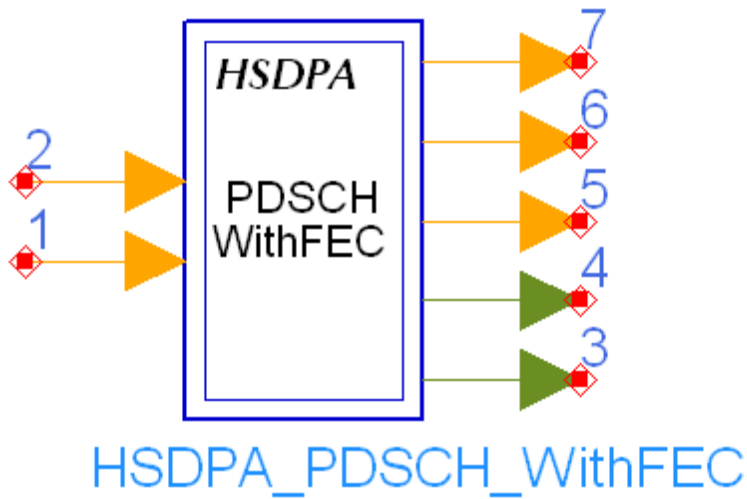

Description: HSDPA PDSCH with coding
 Library: HSDPA, Signal Sources
 Class: SDFHSDPA_PDSCH_WithFEC

Parameters

Name	Description	Default	Type	Range
UE_Category	: Category_1, Category_2, Category_3, Category_4, Category_5, Category_6, Category_7, Category_8, Category_9, Category_10, Category_11, Category_12	Category_1	enum	
TTIPattern	inter-TTI pattern	{1, 0, 1, 0, 1, 0}	int array	[0, 1]
TransBlockSize	Transport block size	3202	int	[1, max transport block size]†
NumHARQ	Number of HARQ processes	1	int	[1, 6]

Advanced Design System 2008

RVSeq	Redundancy and constellation version coding sequence	{0, 2, 5, 6}	int array	[0, 7]
DataPattern	Source data pattern: Random, PN9, PN15, Repeat Bits	Random	enum	
RepeatBitValue	Repeating data value	0x0001	int	[0, 65535]
RepeatBitPeriod	Repeating data period	2	int	[1, 16]
MS	Modulation scheme: _QPSK, _16QAM	_QPSK	enum	
NIR		9600	int	
NumHSPDSCH	number of physical channels	5	int	
SpreadCodeOffset	Spread code offset	1	int	
Power_GainFactor	Power gain factor	-10.0	real	

† Refer to the [FDD E-DCH physical layer categories](#) in the [HSUPA Design Library](#) documentation.

Pin Inputs

Pin	Name	Description	Signal Type
1	CQI	channel quality indicator	int
2	ARQ	automatic repeat request	int

Pin Outputs

Pin	Name	Description	Signal Type
3	DataOut	data out	complex
4	STTDOut	data out	complex
5	RV	redundancy version	int
6	nd	new data indicator	int
7	BitDSCH	DSCH bit	int

Notes/Equations

1. This subnetwork model is used to simulate a full coded HS-PDSCH signal source.

The schematic for this subnetwork is shown below.

HSDPA_PDSCH_WithFEC Schematic

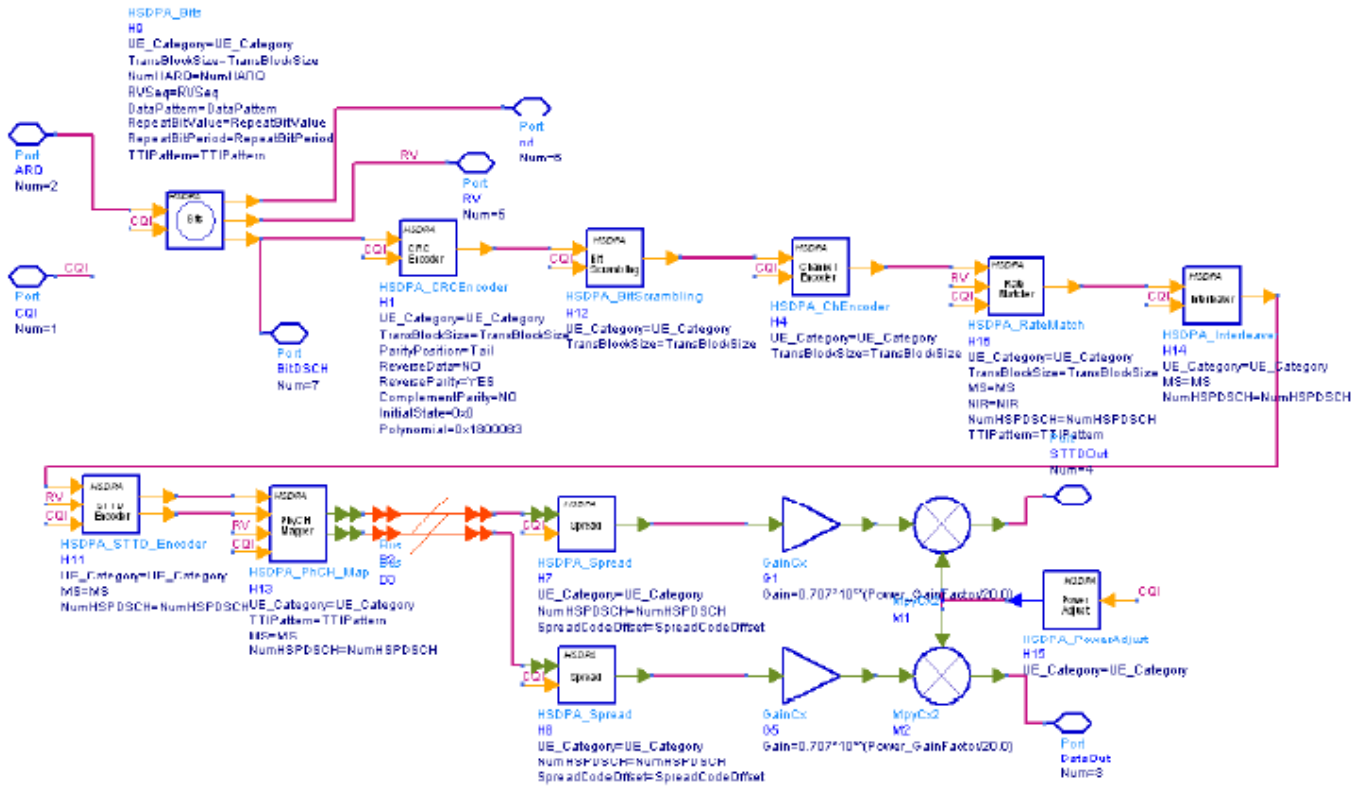

2. The HS_PDSCH_WithFEC generates one full coded HS-PDSCH signal source.
3. For more information about HS-PDSCH parameters, see [HSDPA_RateMatch](#).
4. For more information about HARQ function, see [HSDPA_Bits](#) and [HSDPA_RateMatch](#).
5. For more information about the models used in this subnetwork, see their respective documentation.

References

1. 3GPP Technical Specification TS 25.211, "Physical channels and mapping of transport channels onto physical channels (FDD)," Version 6.7.0, Dec. 2005.
2. 3GPP Technical Specification TS 25.212, "Multiplexing and channel coding (FDD)," Version 6.7.0, Dec. 2005.
3. 3GPP Technical Specification TS 25.213, "Spreading and modulation (FDD)," Version 6.4.0, Dec. 2005.
4. 3GPP Technical Specification TS 25.214, "Physical layer procedures (FDD)," Version 6.7.1, Dec. 2005.

HSDPA_PDSCH_WithoutFEC

HSDPA HS-PDSCH Without FEC

Symbol



HSDPA_PDSCH_WithoutFEC

Description: HSDPA PDSCH without coding

Library: HSDPA, Signal Sources

Class: SDFHSDPA_PDSCH_WithoutFEC

Parameters

Name	Description	Default	Type	Range
TTIPattern	inter-TTI pattern	{1, 0, 1, 0, 1, 0}	int array	[0, 1]
DataPattern	: PN9, PN15, FIX4, _4_1_4_0, _8_1_8_0, _16_1_16_0, _32_1_32_0, _64_1_64_0	PN9	enum	
MS	Modulation scheme: _QPSK, _16QAM	_QPSK	enum	
NumHSPDSCH	number of physical channels	1	int	
SpreadCodeOffset		13	int	
Power_GainFactor	Power gain factor	-10.0	real	

Pin Outputs

Pin	Name	Description	Signal Type
1	DataOut	data out	complex
2	STTDOut	data out	complex

Notes/Equations

1. This subnetwork model is used to simulate an uncoded HS-PDSCH signal source. The schematic for this subnetwork is shown below.

HSDPA_PDSCH_WithoutFEC Schematic

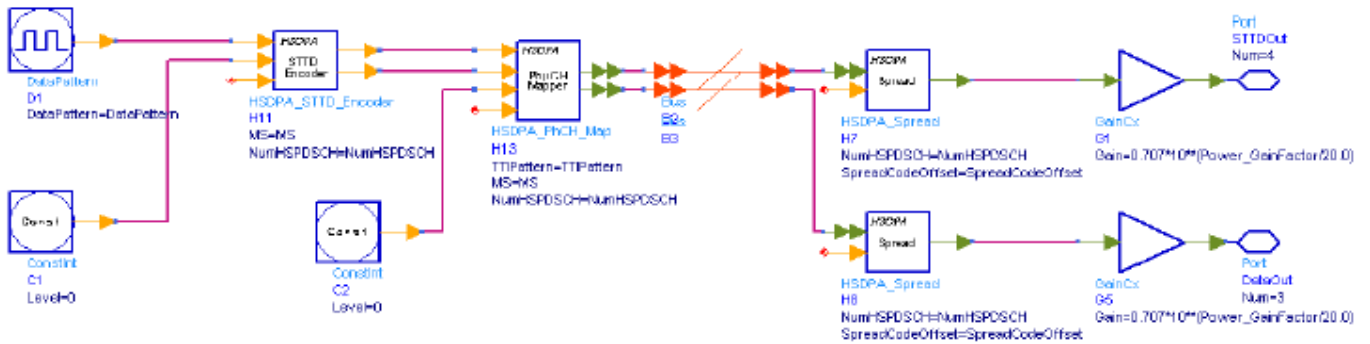

2. The HS_PDSCH_WithoutFEC generates an uncoded HS-PDSCH signal source.
3. For more information about the models used in this subnetwork, see their respective documentation.

References

1. 3GPP Technical Specification TS 25.211, "Physical channels and mapping of transport channels onto physical channels (FDD)," Version 6.7.0, Dec. 2005.
2. 3GPP Technical Specification TS 25.212, "Multiplexing and channel coding (FDD)," Version 6.7.0, Dec. 2005.
3. 3GPP Technical Specification TS 25.213, "Spreading and modulation (FDD)," Version 6.4.0, Sept. 2005.

HSDPA_PhCH_Demap

Physical channel demapper

Symbol

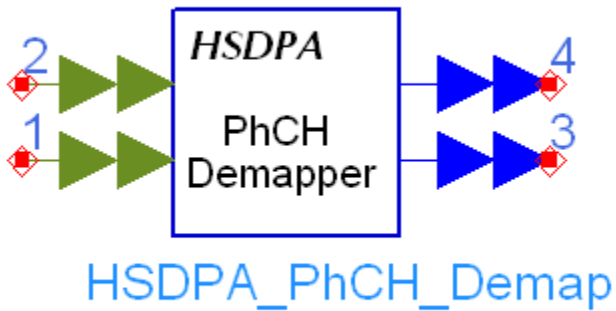

Description: Soft demapper

Library: HSDPA, Demultiplexers & Decoders

Class: SDFHSDPA_PhCH_Demap

Parameters

Name	Description	Default	Type
MS	Modulation scheme: _QPSK, _16QAM	_QPSK	enum
NumHSPDSCH	Number of HS_PDSCH	5	int

Pin Inputs

Pin	Name	Description	Signal Type
1	DataInM	data for physical channel(s)	multiple complex
2	STTDInM	data for physical channel(s)	multiple complex

Pin Outputs

Pin	Name	Description	Signal Type
3	DataOutM	soft-decision data for physical channel(s)	multiple real
4	STTDOutM	soft-decision STTD data for physical channel(s)	multiple real

Notes/Equations

1. This model is used to implement soft-decision modulation demapping of HS-PDSCH.
Each firing, 480 tokens are consumed at pin DataInM, and 480 tokens are consumed at pin STTDInM, while 1920 tokens are generated at pin DataOutM, and 1920 tokens are generated at pin STTDOutM for each HS-PDSCH.
2. The NumHSPDSCH parameter determines the number of HS-PDSCHs. Each HS-PDSCH contains 1920 bits. If the modulation scheme is QPSK, only the first 960 bits are useful data bits, and the other 960 bits are 0s. If the modulation scheme is 16QAM, all 1920 bits are useful data bits.
3. Assuming the received symbols have been normalized to the standard constellation as [QPSK modulation mapping](#) or [16QAM modulation mapping](#), the soft modulation demapping bits can be determined by the decision equations as follows, where I is the real part of product and Q is the imaginary part.
16QAM decision equations are:

$$b0 = I \times \sqrt{5}$$

$$b1 = Q \times \sqrt{5}$$

$$b2 = 2 - |b0|$$

$$b3 = 2 - |b1|$$

QPSK decision equations are:

$$b0 = I$$

$$b1 = Q$$

QPSK modulation mapping

input bit sequence	I branch	Q branch
00	1	1
01	1	-1
10	-1	1

Advanced Design System 2008

11	-1	-1
----	----	----

16QAM modulation mapping

input bit sequence	I branch	Q branch
0000	0.4472	0.4472
0001	0.4472	1.3416
0010	1.3416	0.4472
0011	1.3416	1.3416
0100	0.4472	-0.4472
0101	0.4472	-1.3416
0110	1.3416	-0.4472
0111	1.3416	-1.3416
1000	-0.4472	0.4472
1001	-0.4472	1.3416
1010	-1.3416	0.4472
1011	-1.3416	1.3416
1100	-0.4472	-0.4472
1101	-0.4472	-1.3416
1110	-1.3416	-0.4472
1111	-1.3416	-1.3416

4. The final soft bit informations b are output at pin DataOutM. The final STTD soft bit informations b are output at pin STTDOuM.

References

1. 3GPP Technical Specification TS 25.211, "Physical channels and mapping of transport channels onto physical channels (FDD)," Version 6.7.0, Dec. 2005.
2. 3GPP Technical Specification TS 25.212, "Multiplexing and channel coding (FDD)," Version 6.7.0, Dec. 2005.
3. 3GPP Technical Specification TS 25.213, "Spreading and modulation (FDD)," Version 6.4.0, Sept. 2005.

Unable to render {include} Couldn't find a page to include called: HSDPA PhCH Mapper

HSDPA_PowerAdjust

Power adjust

Symbol

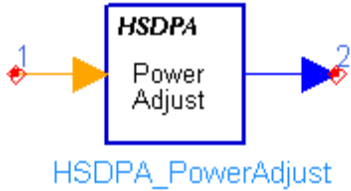

Description: Power adjust

Library: HSDPA, Multiplexers & Coders

Class: SDFHSDPA_PowerAdjust

Parameters

Name	Description	Default	Type
UE_Category	: Category_1, Category_2, Category_3, Category_4, Category_5, Category_6, Category_7, Category_8, Category_9, Category_10, Category_11, Category_12	Category_1	enum

Pin Inputs

Pin	Name	Description	Signal Type
1	CQI	channel quality indicator	int

Pin Outputs

Pin	Name	Description	Signal Type
2	DataOut	data out	real

Notes/Equations

1. This model is used to implement power adjustment.
Each firing, 1 token is consumed at pin CQI if it is connected, while 7680 tokens are generated at pin DataOut.

- If pin CQI is connected, power gain is determined by input CQI value and UE_Category according to Table 7 of 6A.2 in [Reference \[1\]](#). Otherwise, 1.0 is output.

References

- 3GPP Technical Specification TS 25.214, "Physical layer procedure (FDD)" Version 6.7.1, Dec. 2005.

HSDPA_RakeCombine

Combine Signals of Optimum Paths According to Path Estimation

Symbol

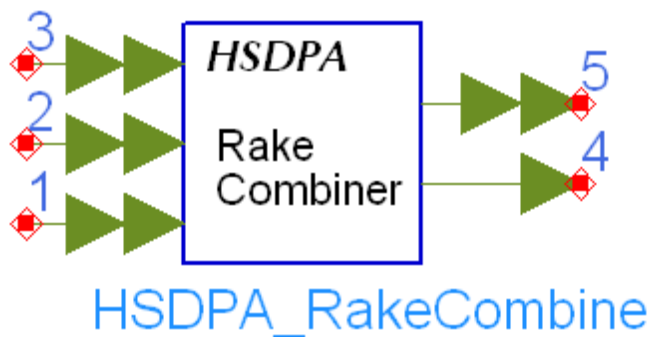

Description: Combine signals of optimum paths according to path estimation

Library: HSDPA, Receiver

Class: SDFHSDPA_RakeCombine

Derived From: HSDPA_RakeBase

Parameters

Name	Description	Default	Sym	Type	Range
TXDiversity	transmit diversity	No_Diversity		enum	

Advanced Design System 2008

	in downlink: No_Diversity, STTD				
PathNum	number of paths or fingers of Rake	6	L	int	[1, 16]
NumHSPDSCH	number of NumHSPDSCH	5	M	int	[1, 15]

Pin Inputs

Pin	Name	Description	Signal Type
1	HSPDSCHSym	de-spread signals of each path for all code channels	multiple complex
2	HSSCHSymI	de-spread signals of each path for all code channels	multiple complex
3	ChEst	path estimation of one slot based on DPCH or CPICH	multiple complex

Pin Outputs

Pin	Name	Description	Signal Type
4	HSSCCH	combined signals of all code channels	complex
5	HSPDSCH	combined signals of all code channels	multiple complex

Notes/Equations

- This model is used to fulfill maximal ratio combining.
Each firing, N tokens are consumed at ChEst per each port, M tokens are consumed at HSPDSCHSym per each port and P tokens are consumed at HSSCCHSym, where N is the number of symbols per TTI in downlink CPICH, M is the number of symbols per TTI in all HS-PDSCHs, P is the number of symbols per TTI in HS-SCCH. Q tokens are produced at HSPDSCH per each port, where Q is the number of symbols per TTI in one HS-PDSCH. P tokens are produced at HSSCCH, where P is the number of symbols per TTI in HS-SCCH. The number of ports at ChEst, HSPDSCHSym and HSSCCHSym depend on PathNum. The number of ports at HSPDSCH depends on the NumHSPDSCH.

References

1. 3GPP Technical Specification TS25.211 V6.7.0, "Physical channels and mapping of transport channels onto physical channels (FDD)," Dec. 2005.
2. S.Tanaka, M.Sawahashi, and F.Adachi, "Pilot Symbol-Assisted Decision-Directed Coherent Adaptive Array Diversity for DS-CDMA Mobile Radio Reverse Link," Proc. Wireless'97, Canada, July 1997.
3. A. J. Viterbi, "CDMA: Principles of Spread Spectrum Communication," Wesley Publishing Company, 1995.

HSDPA_RateDematch

HS-DSCH rate dematcher

Symbol

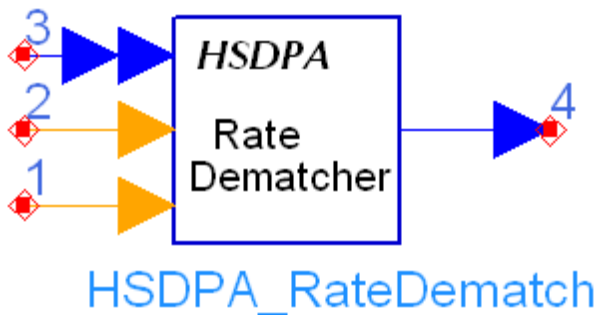

Description: HS_DSCH Rate matching
 Library: HSDPA, Demultiplexers & Decoders
 Class: SDFHSDPA_RateDematch
 Derived From: HSDPA_DSCH_Base

Parameters

Name	Description	Default	Type	Range
TransBlockSize	Transport block size	3202	int	[1, max transport block size]†
MS	Modulation scheme: _QPSK, _16QAM	_QPSK	enum	

Advanced Design System 2008

NIR		9600	int	
NumHSPDSCH	Number of HS_PDSCH	5	int	
NumHARQ	Number of HARQ processes	1	int	[1, 6]
TTIPattern	inter-TTI pattern	{1, 1, 1, 1, 1, 1}	int array	[0, 1]

† Refer to the [FDD E-DCH physical layer categories](#) in the [HSUPA Design Library](#) documentation.

Pin Inputs

Pin	Name	Description	Signal Type
1	RV	redundancy version	int
2	nd	new data indicator	int
3	DataIn	data in	multiple real

Pin Outputs

Pin	Name	Description	Signal Type
4	DataOut	data in	real

Notes/Equations

- This model is used to implement rate dematch for HSDPA downlink. Each firing, $((\text{TransBlockSize} + \text{number of padding bits}) * 3 + \text{code block number} * 12)$ Output tokens are generated while Ndata Input tokens are consumed. Determination of Ndata is described in 4.8.4.1 in [Reference \[2\]](#).
- This model implementation is the inverse operation of HSDPA_RateMatch. For more information, refer to [HSDPA_RateMatch](#).
- The received signal for each HARQ process are buffered in this model. If the input nd is 1 and TTIPattern is 1, current input data will be stored into the buffer of current HARQ process directly. If the input of nd is 0 and TTIPattern is 1, it means the received signal is a redundancy version and there is a previous version stored in the buffer of current HARQ process. Versions of received signal are combined and then stored into buffer of current HARQ process. The data in the buffer for current HARQ process are then fed into channel decoder(s).
- Since the soft combination described above depends on HARQ process and rate dematch is implemented TTI by TTI, the beginning of the first HARQ process must be known to the model. Generally, receiver may introduce some delays into data stream.

References

1. 3GPP Technical Specification TS 25.211, "Physical channels and mapping of transport channels onto physical channels (FDD)," Version 6.7.0, Dec. 2005.
2. 3GPP Technical Specification TS 25.212, "Multiplexing and channel coding (FDD)," Version 6.7.0, Dec. 2005.
3. 3GPP Technical Specification TS 25.213, "Spreading and modulation (FDD)," Version 6.4.0, Dec. 2005.

HSDPA_RateMatch

HS-DSCH rate matcher

Symbol

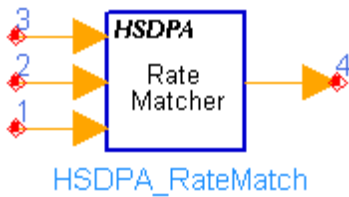

Description: HS_DSCH Rate matching
 Library: HSDPA, Multiplexers & Coders
 Class: SDFHSDPA_RateMatch
 Derived From: HSDPA_DSCH_Base

Parameters

Name	Description	Default	Type	Range
UE_Category	: Category_1, Category_2, Category_3, Category_4, Category_5, Category_6, Category_7, Category_8, Category_9, Category_10, Category_11, Category_12	Category_1	enum	
TransBlockSize	Transport block size	3202	int	[1, max transport block size]†

Advanced Design System 2008

MS	Modulation scheme: _QPSK, _16QAM	_QPSK	enum	
NIR		9600	int	
NumHSPDSCH	Number of HS_PDSCH	5	int	
TTIPattern	inter-TTI pattern	{1, 1, 1, 1, 1, 1}	int array	[0, 1]

† Refer to the [FDD E-DCH physical layer categories](#) in the [HSUPA Design Library](#) documentation.

Pin Inputs

Pin	Name	Description	Signal Type
1	CQI	channel quality indicator	int
2	RV	redundancy version	int
3	DataIn	data in	int

Pin Outputs

Pin	Name	Description	Signal Type
4	DataOut	data out	int

Notes/Equations

1. This model is used to implement rate match defined in 4.5.4 in [Reference \[2\]](#) for HSDPA downlink. Each firing, Ndata Output tokens are generated while $((\text{TransBlockSize} + \text{number of padding bits}) * 3 + \text{code block number} * 12)$ Input tokens consumed. Determination of Ndata and number of HS-PDSCH is described in 4.5.4.1 in [Reference \[2\]](#).
2. The process of bit separation, rate match with specific RV value and bit collection can be found in 4.5.4 in [Reference \[2\]](#).

References

1. 3GPP Technical Specification TS 25.211, "Physical channels and mapping of transport channels onto physical channels (FDD)," Version 6.7.0, Dec. 2005.
2. 3GPP Technical Specification TS 25.212, "Multiplexing and channel coding (FDD)," Version 6.7.0, Dec. 2005.
3. 3GPP Technical Specification TS 25.213, "Spreading and modulation (FDD)," Version 6.4.0, Dec. 2005.
4. 3GPP Technical Specification TS 25.214, "Physical layer procedures (FDD)," Version 6.7.1, Dec. 2005.

HSDPA_SCCH

HSDPA HS-SCCH channel

Symbol

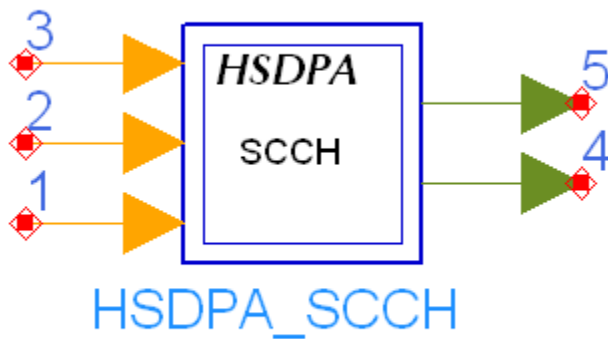

Description: HS-SCCH
 Library: HSDPA, Signal Sources
 Class: SDFHSDPA_SCCH

Parameters

Name	Description	Default	Unit	Type	Range
UE_Category	UE category	1		int	
UEIdentity	UE identity (16 bits)	0B1010101010101010		int	[0, 66535]
HSDPA_FRC	Fixed reference channel: H-Set 1, H-Set 2, H-Set 3, H-Set 4, H-Set 5, H-Set 6, UserDefined	H-Set 1		enum	
TTIPattern	inter-TTI pattern	1 0 0 1 0 0		int array	[0, 1]
MS	Modulation scheme: QPSK,	QPSK		enum	

Advanced Design System 2008

	_16QAM				
NumHARQ	Number of HARQ processes	1		int	[1, 6]
HS_PDSCH_CodeOffset	Spread code offset	1		int	
HSSCCH_EcToIor	HS-SCCH power gain in dB	-10.0	dB	real	$(-\infty, \infty)$
HSSCCH_SpreadCode	Spread code for HS-SCCH	4		int	[0, 127]
ScrambleCode	index of scramble code	0		int	[0, 511]
ScrambleOffset	scramble code offset	0		int	[0, 15]
ScrambleType	scramble code type: normal, right, left	normal		enum	
HS_PDSCH_NumCh	number of HS-PDSCH channels, valid when HSDPA_FRC = UserDefined	1		int	

Pin Inputs

Pin	Name	Description	Signal Type
1	CQI	channel quality indicator	int
2	Xrv	redundancy and constellation version (3 bits)	int
3	Xnd	new data indicator (1 bit)	int

Pin Outputs

Pin	Name	Description	Signal Type
4	Output	output	complex
5	STTD	space time transmit diversity output	complex

5. The physical channel structure of the HS-SCCH is illustrated below. The first slot carries critical information for HS-PDSCH reception, such as the channelization code set (7 bits) and the modulation scheme (1 bit). The second and third slots carry the HS-DSCH channel coding information, such as the transport block size (6 bits), HARQ information (3 bits), the redundancy and constellation version (3 bits), and the new data indicator (1 bit).

Structure of the HS-SCCH (Ref: 3GPP TS 25.211 5.3.3.12)

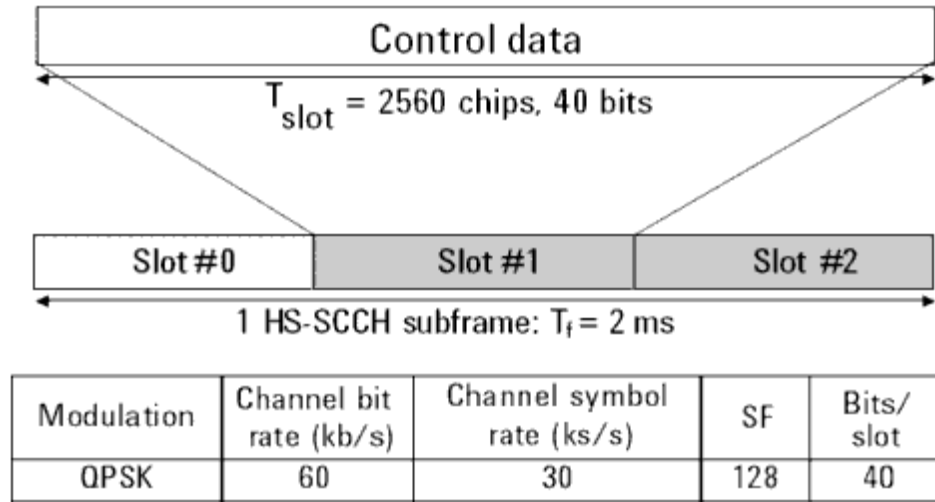

6. The overall coding chain for HS-SCCH is illustrated below. If the pin CQI is connected, then X_{ccs} , X_{tbs} and X_{ms} are calculated according to Table 7 of 6A.2 in [Reference \[2\]](#). If the pin CQI is unconnected, then X_{ccs} , X_{tbs} and X_{ms} are calculated according to the section A.7 of [Reference \[3\]](#). At the end of coding chain, the signal of each slot is spreaded and scrambled as defined in [Reference \[2\]](#), then output at pin output (non STTD). Pin STTD outputs the signal with STTD encoding.

Coding chain for HS-SCCH

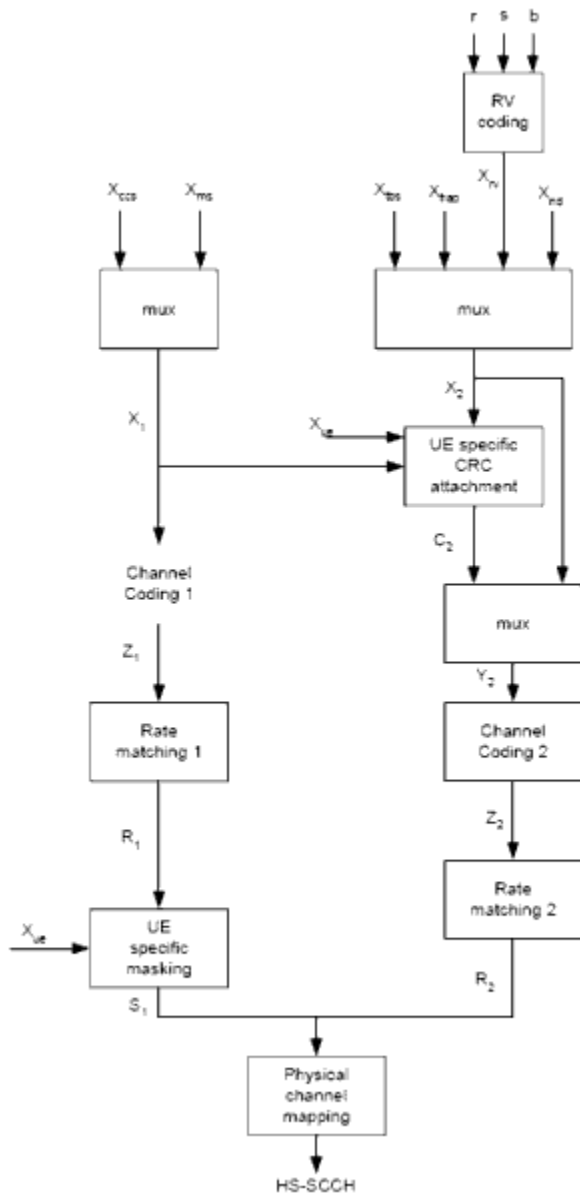

7. If ScrambleType is normal, the scramble code index for HS-SCCH is equal to $\text{ScrambleCode} \times 16 + \text{ScrambleOffset}$. If ScrambleType is right, the index is $\text{ScrambleCode} \times 16 + \text{ScrambleOffset} + 16384$. If ScrambleType is left, the index is $\text{ScrambleCode} \times 16 + \text{ScrambleOffset} + 8192$.

References

1. 3GPP Technical Specification TS 25.212, "Multiplexing and channel coding (FDD)," Version 6.7.0, Dec. 2005.
2. 3GPP Technical Specification TS 25.214, "Physical layer procedures (FDD)," Version 6.7.1, Dec. 2005.
3. 3GPP Technical Specification TS 25.101, "User Equipment (UE) radio transmission and reception (FDD)," Version

6.10.0, Dec. 2005.

HSDPA_SCCH_1_4

HSDPA HS-SCCH channels

Symbol

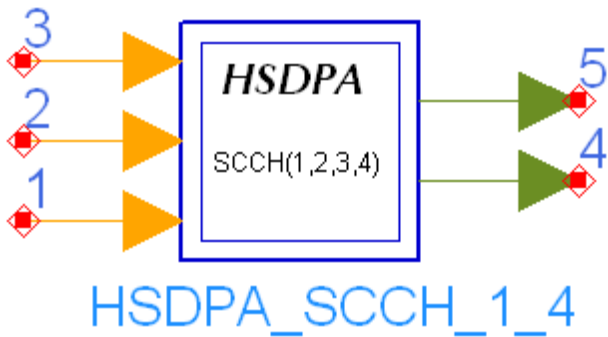

Description: HS-SCCH
 Library: HSDPA, Signal Sources
 Class: SDFHSDPA_SCCH_1_4

Parameters

Name	Description	Default	Unit	Type	Range
HS_SCCH_Configured		{1, 0, 0, 0}		int array	
UE_Category	UE category	{1, 1, 1, 1}		int array	
UEIdentity	UE identity (16 bits)	{0xAAAA, 0x12AA, 0x1AAA, 0x1FAA}		int array	[0, 66535]
HS_PDSCH_MS	Modulation scheme	{0, 0, 0, 0}		int array	
NumHARQ	Number of HARQ	{1, 1, 1, 1}		int array	[1, 6]

Advanced Design System 2008

	processes				
HS_PDSCH_CodeOffset	Spread code offset	{1, 13, 14, 15}		int array	
HS_SCCH_EcToIor	Power gain factor	{-9, -9, -9, -9}	dB	real array	
HS_SCCH_SpreadCode	Spread code for HS-SCCH	{4, 5, 6, 7}		int array	[0, 127]
HS_SCCH_ScrambleCode	Code of scramble code	{0, 0, 0, 0}		int array	[0, 511]
HS_SCCH_ScrambleCodeOffset	Scramble code offset	{0, 0, 0, 0}		int array	[0, 15]
HSDPA_FRC_1	Fixed reference channel: H-Set 1_1, H-Set 2_1, H-Set 3_1, H-Set 4_1, H-Set 5_1, H-Set 6_1, UserDefined_1	H-Set 1_1		enum	
HS_SCCH_1_TTIPattern	TTI pattern	{1, 0, 0, 1, 0, 0}		int array	[0, 1]
HS_SCCH_1_ScrambleCodeType	Scramble code type: normal_1, right_1, left_1	normal_1		enum	
HSDPA_FRC_2	Fixed reference channel: H-Set 1_2, H-Set 2_2, H-Set 3_2, H-Set 4_2, H-Set 5_2, H-Set 6_2, UserDefined_2	H-Set 1_2		enum	
HS_SCCH_2_TTIPattern	TTI pattern	{1, 0, 0, 1, 0, 0}		int array	[0, 1]
HS_SCCH_2_ScrambleCodeType	Scramble code type: normal_2, right_2, left_2	normal_2		enum	
HSDPA_FRC_3	Fixed reference channel: H-Set 1_3, H-Set 2_3, H-Set 3_3, H-Set 4_3, H-Set 5_3, H-Set 6_3, UserDefined_3	H-Set 1_3		enum	
HS_SCCH_3_TTIPattern	TTI pattern	{1, 0, 0, 1, 0, 0}		int array	[0, 1]
HS_SCCH_3_ScrambleCodeType	Scramble code type	normal_3		enum	

Advanced Design System 2008

	type: normal_3, right_3, left_3				
HSDPA_FRC_4	Fixed reference channel: H-Set 1_4, H-Set 2_4, H-Set 3_4, H-Set 4_4, H-Set 5_4, H-Set 6_4, UserDefined_4	H-Set 1_4		enum	
HS_SCCH_4_TTI	Pattern-TTI pattern	{1, 0, 0, 1, 0, 0}		int array	[0, 1]
HS_SCCH_4_ScramblingCode	Scrambling code type: normal_4, right_4, left_4	normal_4		enum	
HS_PDSCH_NumChannels	number of physical channels for HS-DSCHs, valid when the corresponding HSDPA_FRC = UserDefined	{1, 1, 1, 1}		int array	

Pin Inputs

Pin	Name	Description	Signal Type
1	CQI	channel quality indicator	int
2	Xrv	redundancy and constellation version (3 bits)	int
3	Xnd	new data indicator (1 bit)	int

Pin Outputs

Pin	Name	Description	Signal Type
4	Output	output	complex
5	STTD	space time transmit diversity output	complex

Notes/Equations

1. This subnetwork model is used to generate the baseband signal of up to four HS-SCCHs. The HS-SCCH carries signaling information related to the HS-DSCH transport channel transmission. The HS-SCCH bit rate is fixed at

60 Kb/s, but its code number can be configured. Each UE monitors up to four of these channels (known as the HS-SCCH set) simultaneously. The schematic for this subnetwork is shown below.

HSDPA_SCCH_1_4 Schematic

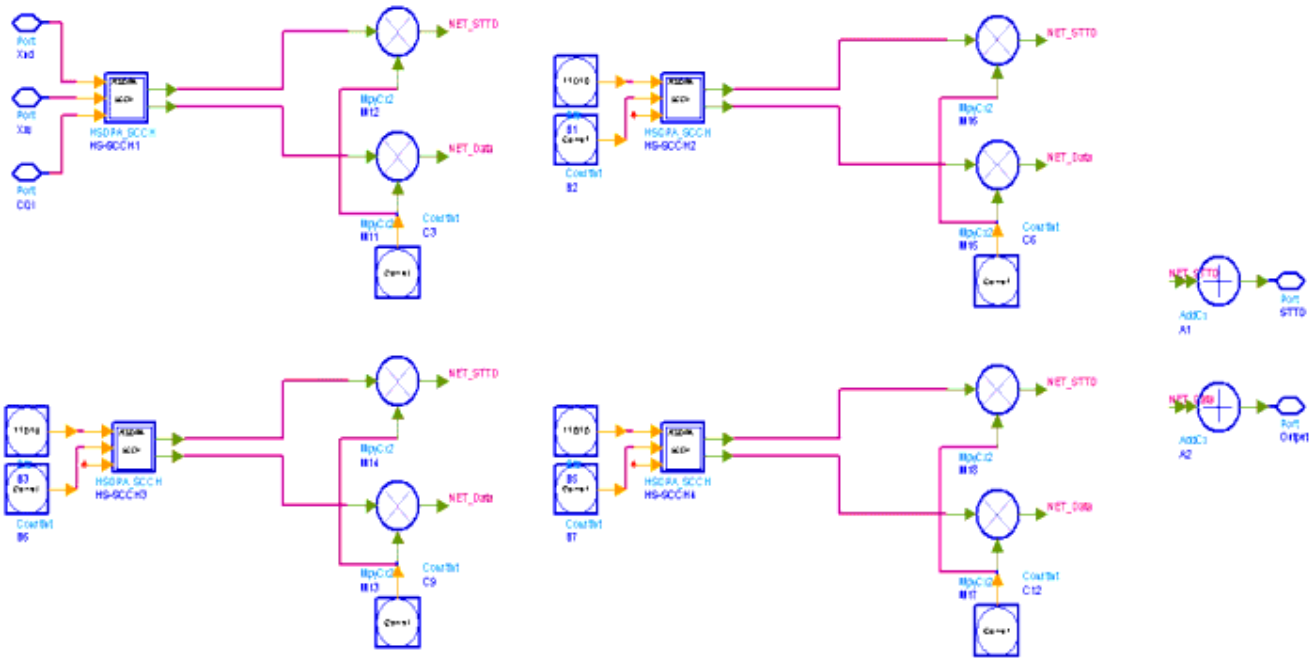

- The input pin CQI is optional. If connected, the input value of CQI should be in the range of 1 to 30. The pin Xrv inputs redundancy and constellation version indicator. The pin Xnd inputs new data indicator.
- The parameter HSDPA_FRC determines the fixed reference channel set for HSDPA tests. The fixed reference channel is defined in section A.7 [Reference \[3\]](#).
- This subnetwork model can output up to 4 HS-SCCHs. The parameter HS_SCCH_Configured determines the number of HS-SCCH channels. It is an int array type parameter. If HS_SCCH_Configured[i]=1, then the number i HS-SCCH channel is active, otherwise inactive (i is a integer number, can be 1, 2, 3 or 4).
- The parameter HS_PDSCH_NumCh is used to generate the HS-DSCH channel coding information in HS-SCCH. It is an int array type parameter. Its element is valid only when the corresponding HSDPA_FRC = UserDefined.
- The physical channel structure of the HS-SCCH is illustrated below. The first slot carries critical information for HS-PDSCH reception, such as the channelization code set (7 bits) and the modulation scheme (1 bit). The second and third slots carry the HS-DSCH channel coding information, such as the transport block size (6 bits), HARQ information (3 bits), the redundancy and constellation version (3 bits), and the new data indicator (1 bit).

Structure of the HS-SCCH (Ref: 3GPP TS 25.211 5.3.3.12)

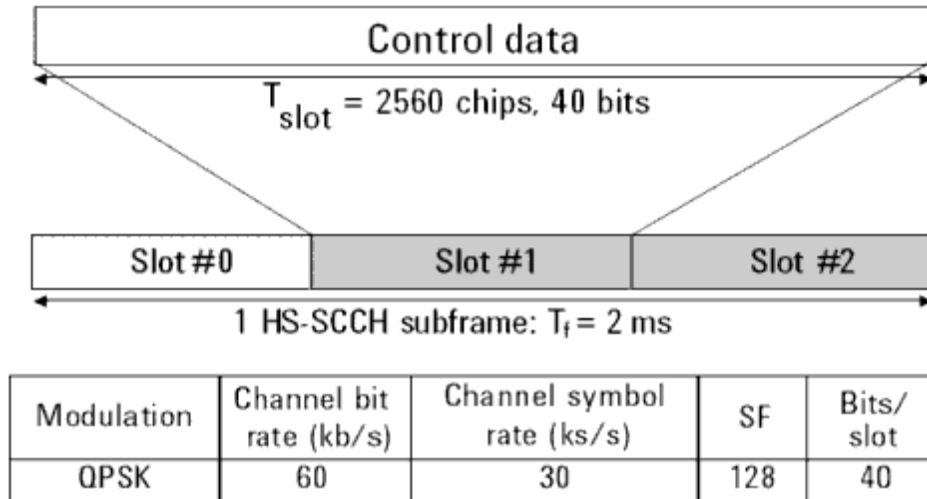

7. The HS-SCCH baseband signal is generated by subnetwork HSDPA_SCCH. The overall coding chain for HS-SCCH is illustrated below. If the pin CQI is connected, then X_{ccs}, X_{tbs} and X_{ms} are calculated according to Table 7 of 6A.2 in [Reference \[2\]](#). If the pin CQI is unconnected, then X_{ccs}, X_{tbs} and X_{ms} are calculated according to the section A.7 of [Reference \[3\]](#). At the end of coding chain, the signal of each slot is spreaded and scrambled as defined in [Reference \[2\]](#), then output at pin output (non STTD). Pin STTD outputs the signal with STTD encoding.

Coding chain for HS-SCCH

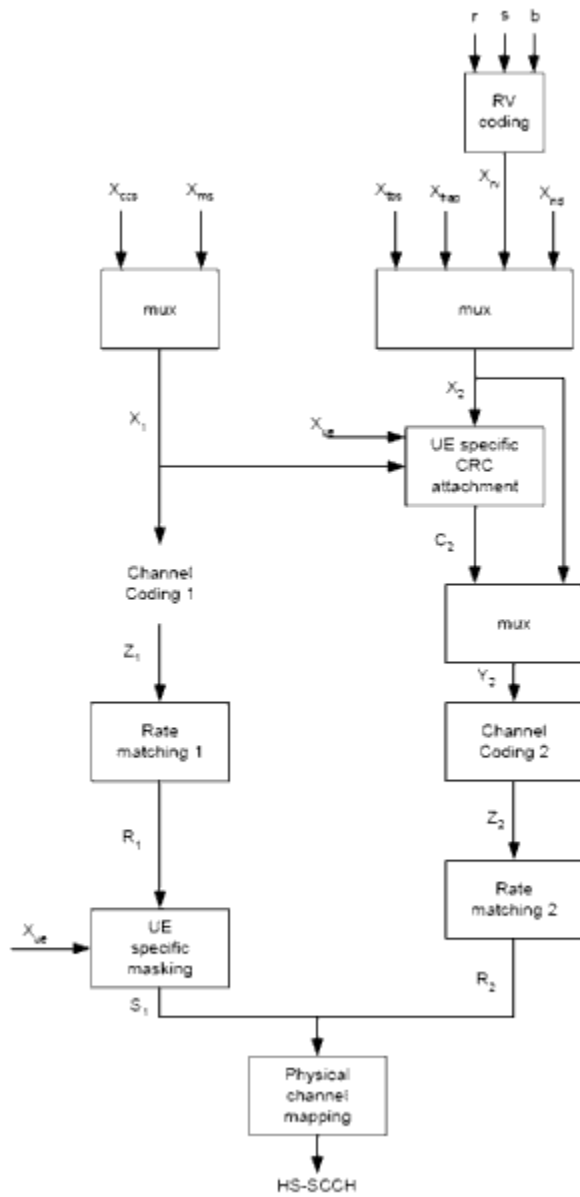

8. If ScrambleType is normal, the scramble code index for the corresponding HS-SCCH is equal to $\text{ScrambleCode} \times 16 + \text{ScrambleOffset}$. If ScrambleType is right, the index is $\text{ScrambleCode} \times 16 + \text{ScrambleOffset} + 16384$. If ScrambleType is left, the index is $\text{ScrambleCode} \times 16 + \text{ScrambleOffset} + 8192$.

References

1. 3GPP Technical Specification TS 25.212, "Multiplexing and channel coding (FDD)," Version 6.7.0, Dec. 2005.
2. 3GPP Technical Specification TS 25.214, "Physical layer procedures (FDD)," Version 6.7.1, Dec. 2005.
3. 3GPP Technical Specification TS 25.101, "User Equipment (UE) radio transmission and reception (FDD)," Version

6.10.0, Dec. 2005.

HSDPA_SCCH_Decoder

HSDPA HS-SCCH decoder

Symbol

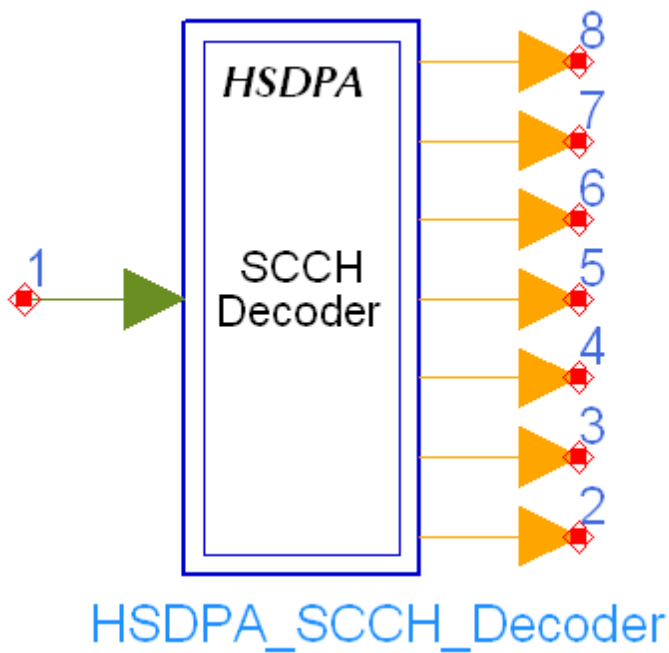

Description: HS-SCCH decoder
 Library: HSDPA, Demultiplexers & Decoders
 Class: SDFHSDPA_SCCH_Decoder

Parameters

Name	Description	Default	Type	Range
UEIdentity	UE identity (16 bits)	0xAAAA	int	[0, 66535]

Pin Inputs

Advanced Design System 2008

Pin	Name	Description	Signal Type
1	DataIn	SCCH input	complex

Pin Outputs

Pin	Name	Description	Signal Type
2	Xccs	channelization code set	int
3	Xms	modulation scheme	int
4	Xtbs	transport-block size information	int
5	Xhap	HARQ process information (3 bits)	int
6	Xrv	redundancy and constellation version (3 bits)	int
7	Xnd	new data indicator (1 bit)	int
8	SCCHCRC	SCCH CRC result	int

Notes/Equations

1. This subnetwork model is used to decode the baseband signal of HS-SCCH as defined in [Reference \[1\]](#). The schematic for this subnetwork is shown below.

HSDPA_SCCH_Decoder Schematic

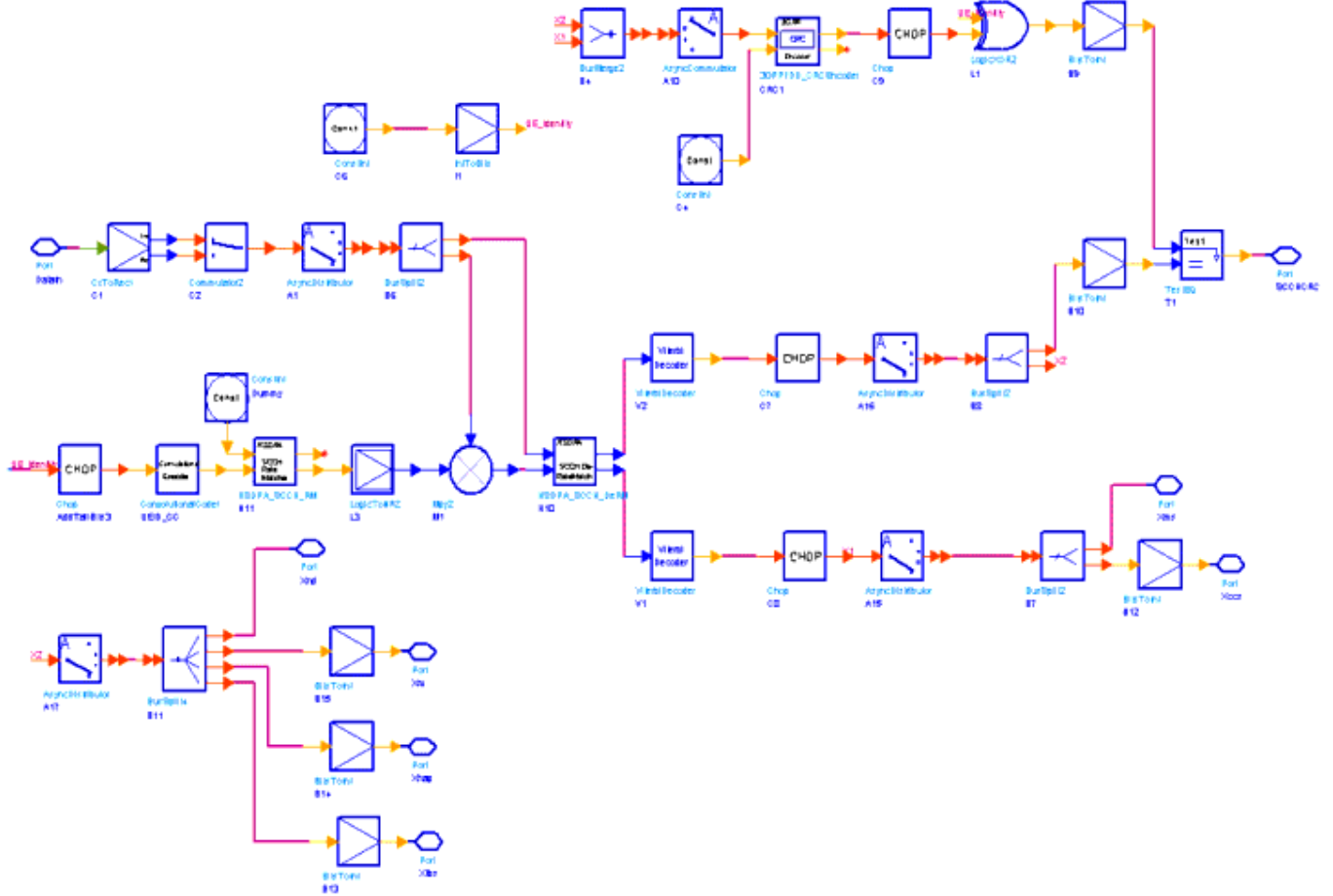

- For each received HS-SCCH sub-frame, error-detection is performed by checking the CRC. If there is no error, the pin SCCHCRC outputs 1 (otherwise outputs 0).

References

- 3GPP Technical Specification TS 25.212, "Multiplexing and channel coding (FDD)," Version 6.7.0, Dec. 2005.

HSDPA_SCCH_DeRM

HS-SCCH rate dematcher

Symbol

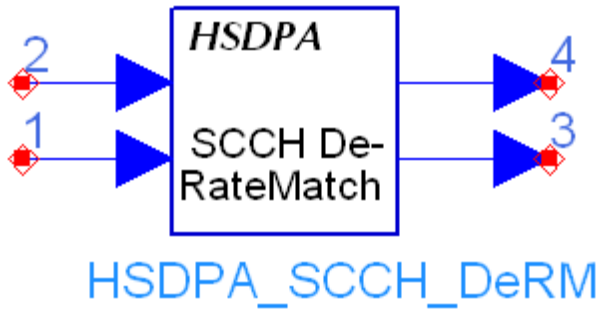

Description: HS-SCCH de-rateMatching
 Library: HSDPA, Demultiplexers & Decoders
 Class: SDFHSDPA_SCCH_DeRM

Pin Inputs

Pin	Name	Description	Signal Type
1	R1	input data 1	real
2	R2	input data 2	real

Pin Outputs

Pin	Name	Description	Signal Type
3	Z1	output data 1	real
4	Z2	output data 2	real

Notes/Equations

1. This model is used to implement rate dematching for HS-SCCH as defined in 4.6.6 in [Reference \[1\]](#). Each firing, 48 Z1 tokens and 111 Z2 are generated, while 40 R1 tokens, 80 R2 tokens tokens are consumed.

References

1. 3GPP Technical Specification TS 25.212, "Multiplexing and channel coding (FDD)," Version 6.7.0, Dec. 2005.

HSDPA_SCCH_ParaCalc

HSDPA HS-SCCH parameter calculator

Symbol

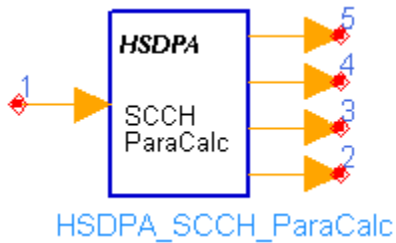

Description: HS-SCCH CQI Mapping
 Library: HSDPA, Multiplexers & Coders
 Class: SDFHSDPA_SCCH_ParaCalc

Parameters

Name	Description	Default	Type	Range
UE_Category	UE category: Category_1, Category_2, Category_3, Category_4, Category_5, Category_6, Category_7, Category_8, Category_9, Category_10, Category_11, Category_12	Category_1	enum	
HSDPA_FRC	Fixed reference channel: H-Set 1, H-Set 2, H-Set 3, H-Set 4, H-Set 5, H-Set 6, UserDefined	H-Set 1	enum	
MS	Modulation scheme: QPSK, _16QAM	QPSK	enum	
NumHARQ	Number of HARQ	1	int	[1, 6]

Advanced Design System 2008

	processes, only valid when port CQI is connected			
HS_PDSCH_CodeOffset	Spread code offset	1	int	[1, 15]
HS_PDSCH_NumCh	Number of HS-PDSCH channels, valid when HSDPA_FRC = UserDefined	1	int	[1, 15]

Pin Inputs

Pin	Name	Description	Signal Type
1	CQI	channel quality indicator	int

Pin Outputs

Pin	Name	Description	Signal Type
2	Xhap	HARQ process information (3 bits)	int
3	Xms	Modulation scheme information (1 bit)	int
4	Xtbs	transport-block size information (6 bits)	int
5	Xccs	channelization-code-set information (7 bits)	int

Notes/Equations

1. This model is used to calculate the Xccs, Xtbs, Xms and Xhap parameters of HS-SCCH as defined in [Reference \[1\]](#).
2. The input pin CQI is optional. If connected, the input value of CQI should be in the range of 1 to 30.
3. Xccs, Xtbs, Xms and Xhap are used to generate HS-SCCH message. The overall coding chain for HS-SCCH is illustrated below. If the pin CQI is connected, then Xccs, Xtbs and Xms are calculated according to Table 7 of 6A.2 in [Reference \[2\]](#), and Xhap is determined by the parameter NumHARQ. If the pin CQI is unconnected, then Xccs, Xtbs and Xhap are calculated according to the section A.7 of [Reference \[3\]](#), and Xms is determined by the parameter MS.

Coding chain for HS-SCCH

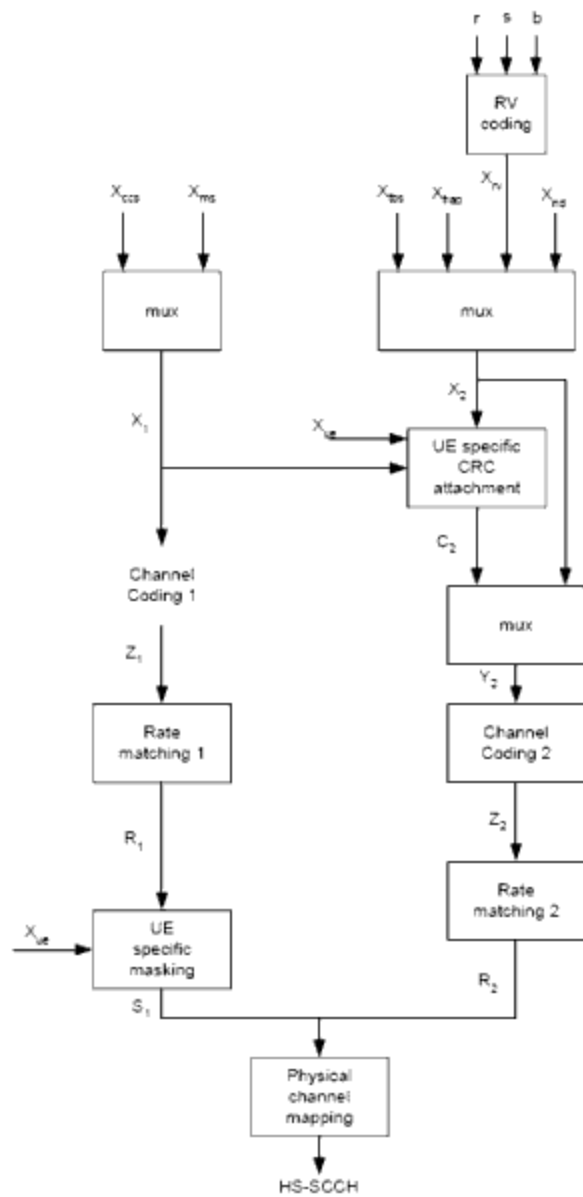

4. X_{ccs} is a channelization-code-set information (7 bits). It is coded according to section 4.6.2.3 [Reference \[1\]](#).
5. X_{tbs} is a transport-block size information (6 bits). It is coded according to section 4.6.2.6 [Reference \[1\]](#).
6. X_{ms} is a modulation scheme information (1 bit). If modulation scheme is QPSK, then $X_{ms}=0$; and if modulation scheme is 16QAM, then $X_{ms}=1$.
7. X_{hap} is a hybrid-ARQ process information (3 bits). It is coded according to section 4.6.2.5 [Reference \[1\]](#).

References

1. 3GPP Technical Specification TS 25.212, "Multiplexing and channel coding (FDD)," Version 6.7.0, Dec. 2005.

2. 3GPP Technical Specification TS 25.214, "Physical layer procedures (FDD)," Version 6.7.1, Dec. 2005.
3. 3GPP Technical Specification TS 25.101, "User Equipment (UE) radio transmission and reception (FDD)," Version 6.10.0, Dec. 2005.

HSDPA_SCCH_RM

HS-SCCH rate matcher

Symbol

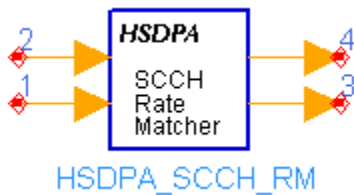

Description: HS-SCCH Rate Matching
 Library: HSDPA, Multiplexers & Coders
 Class: SDFHSDPA_SCCH_RM

Pin Inputs

Pin	Name	Description	Signal Type
1	Z1	input data 1	int
2	Z2	input data 2	int

Pin Outputs

Pin	Name	Description	Signal Type
3	R1	output data 1	int
4	R2	output data 2	int

Notes/Equations

1. This model is used to implement rate matching for HS-SCCH as defined in 4.6.6 in [Reference \[1\]](#). Each firing, 40 R1 tokens, 80 R2 tokens are generated, while 48 Z1 tokens and 111 Z2 tokens are consumed.

References

1. 3GPP Technical Specification TS 25.212, "Multiplexing and channel coding (FDD)," Version 6.7.0, Dec. 2005.

HSDPA_SCH

HSDPA SCH channel

Symbol

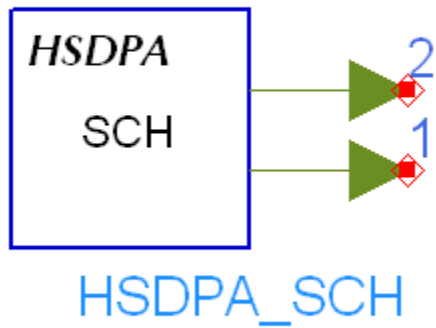

Description: Synchronization Channel

Library: HSDPA, Signal Sources

Class: SDFHSDPA_SCH

Parameters

Name	Description	Default	Type	Range
OutputSTTD	: NO, YES	YES	enum	
ScrambleCode	index of scramble code	0	int	[0, 511]
SCHType	SCH type: Primary,	Primary	enum	

	Secondary			
--	-----------	--	--	--

Pin Outputs

Pin	Name	Description	Signal Type
1	Output	SCH output on antenna 1	complex
2	TSTD	SCH transmitter by TSTD on antenna 2	complex

Notes/Equations

1. This model can be used to generate P-SCH or S-SCH.
2. SCHType = Secondary specifies the cell's downlink scrambling code group.
When SCHType = Primary, ScrambleCode is not used.

References

1. 3GPP Technical Specification TS 25.211, "Physical channels and mapping of transport channels onto physical channels (FDD)," Version 6.7.0, Dec. 2005.
2. 3GPP Technical Specification TS 25.213, "Spreading and modulation (FDD)," Version 6.4.0, Sept. 2005.

HSDPA_Spread

Physical channel spreader

Symbol

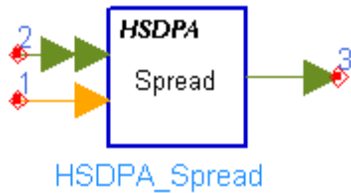

Description: Physical channel spreader

Advanced Design System 2008

Library: HSDPA, Multiplexers & Coders
 Class: SDFHSDPA_Spread

Parameters

Name	Description	Default	Type
UE_Category	: Category_1, Category_2, Category_3, Category_4, Category_5, Category_6, Category_7, Category_8, Category_9, Category_10, Category_11, Category_12	Category_1	enum
NumHSPDSCH	Number of HS PDSCH	5	int
SpreadCodeOffset	Spread code offset	1	int

Pin Inputs

Pin	Name	Description	Signal Type
1	CQI	channel quality indicator	int
2	DataInM	data in	multiple complex

Pin Outputs

Pin	Name	Description	Signal Type
3	DataOut	data for physical channel(s)	complex

Notes/Equations

- This model is used to implement spreading on HS-PDSCH. Each firing, 480 tokens are consumed for each HS-PDSCH, which corresponds to one sub-port of pin DataInM, and 1 token is consumed at pin CQI if it is connected, while 480×16 tokens are generated at pin DataOut.
- If pin CQI is connected, number of HS-PDSCHs occupied (EffectiveNumHSPDSCH) is determined by input CQI value and UE_Category according to Table 7 of 6A.2 in [Reference \[4\]](#). Otherwise, EffectiveNumHSPDSCH equals to NumHSPDSCH.
- OVSF codes with length 16 and index from SpreadCodeOffset to SpreadCodeOffset+EffectiveNumHSPDSCH-1 are assigned to the EffectiveNumHSPDSCH HS-PDSCHs respectively. Spreading is performed on each token within one HS-PDSCH with the OVSF code assigned to the HS-PDSCH. So 480×16 tokens are generated for each HS-PDSCH.
- The spread tokens for each HS-PDSCH are summed together and output at pin DataOut.

References

1. 3GPP Technical Specification TS 25.211, "Physical channels and mapping of transport channels onto physical channels (FDD)," Version 6.7.0, Dec. 2005.
2. 3GPP Technical Specification TS 25.212, "Multiplexing and channel coding (FDD)," Version 6.7.0, Dec. 2005.
3. 3GPP Technical Specification TS 25.213, "Spreading and modulation (FDD)," Version 6.4.0, Dec. 2005.
4. 3GPP Technical Specification TS 25.214, "Physical layer procedures (FDD)," Version 6.7.1, Dec. 2005.

HSDPA_STTD_Decoder

STTD decoder

Symbol

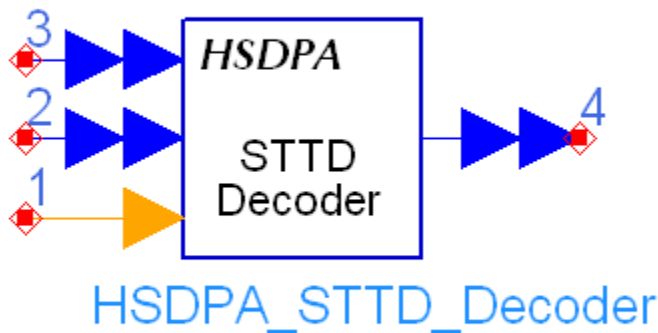

Description: STTD decoder

Library: HSDPA, Demultiplexers & Decoders

Class: SDFHSDPA_STTD_Decoder

Parameters

Name	Description	Default	Type
MS	Modulation scheme:	_QPSK	enum

Advanced Design System 2008

	_QPSK, _16QAM		
NumHSPDSCH	Number of HS_PDSCH	5	int

Pin Inputs

Pin	Name	Description	Signal Type
1	RV	redundancy version	int
2	DataInM	data in	multiple real
3	STTDInM	sttd in	multiple real

Pin Outputs

Pin	Name	Description	Signal Type
4	DataOutM	data out	multiple real

Notes/Equations

- This model is used to perform the inverse operation of constellation re-arrangement for 16QAM and will be updated to perform STTD decoding in the future.
Each firing, 1920 tokens are consumed at each sub-port of pin DataInM, 1920 tokens at each sub-port of pin STTDInM, and 1 token is consumed at pin RV, while 1920 tokens are generated at each sub-port of pin DataOutM.
- NumHSPDSCH specifies the number of HS-PDSCHs to be processed and each HS-PDSCH occupies one sub-port of pin DataInM and one sub-port of pin DataOutM. MS specifies the modulation scheme of each HS-PDSCH.
- For QPSK, the 1920 bits consumed at each sub-port of DataInM will pass through this model transparently and output at each sub-port of DataOutM. For 16QAM, the 1920 bits are grouped four by four. The operation which is inverse to that shown in [Constellation re-arrangement for 16QAM](#).
- The tokens consumed at pin STTDIn are not processed inside the model now. In the future, STTD decoding and combining with the tokens from DataInM will be performed.

Constellation re-arrangement for 16QAM

constellation version parameter b	Output bit sequence	Operation
0	$v_{p,k}, v_{p,k+1}, v_{p,k+2}, v_{p,k+3}$	None
1	$v_{p,k+2}, v_{p,k+3}, v_{p,k}, v_{p,k+1}$	Swapping MSBs with LSBs
2	$v_{p,k}, v_{p,k+1}, \overline{v_{p,k+2}}, \overline{v_{p,k+3}}$	Inversion of the logical values of LSBs
3	$v_{p,k+2}, v_{p,k+3}, \overline{v_{p,k}}, \overline{v_{p,k+1}}$	Swapping MSBs with LSBs and inversion of the logical values of

		LSBs
--	--	------

References

1. 3GPP Technical Specification TS 25.211, "Physical channels and mapping of transport channels onto physical channels (FDD)," Version 6.7.0, Dec. 2005.
2. 3GPP Technical Specification TS 25.212, "Multiplexing and channel coding (FDD)," Version 6.7.0, Dec. 2005.

HSDPA_STTD_Encoder

STTD encoder

Symbol

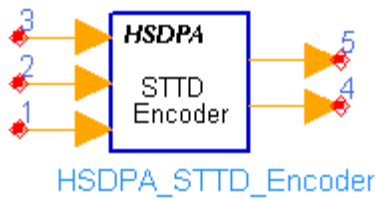

Description: STTD encoder
 Library: HSDPA, Multiplexers & Coders
 Class: SDFHSDPA_STTD_Encoder

Parameters

Name	Description	Default	Type
UE_Category	: Category_1, Category_2, Category_3, Category_4, Category_5, Category_6, Category_7, Category_8, Category_9, Category_10, Category_11, Category_12	Category_1	enum
MS	Modulation scheme: _QPSK, _16QAM	_QPSK	enum
NumHSPDSCH	Number of HS_PDSCH	5	int

Advanced Design System 2008

Pin Inputs

Pin	Name	Description	Signal Type
1	CQI	channel quality indicator	int
2	RV	redundancy version	int
3	DataIn	data in	int

Pin Outputs

Pin	Name	Description	Signal Type
4	DataOut	data out	int
5	STTDOut	sttd out	int

Notes/Equations

- This model is used to implement constellation re-arrangement for 16QAM and STTD encoding. Each firing, $1920 \times \text{MaxNumHSPDSCH}$ tokens are consumed at pin DataIn, 1 token is consumed at pin CQI if it is connected, and 1 token is consumed at pin RV, while $1920 \times \text{MaxNumHSPDSCH}$ tokens are generated at pin DataOut, and $1920 \times \text{MaxNumHSPDSCH}$ tokens are generated at pin STTDOut. $1920 \times \text{MaxNumHSPDSCH}$ is the possible maximum data bits and MaxNumHSPDSCH is the possible maximum HS-PDSCHs within one TTI. If pin CQI is connected, MaxNumHSPDSCH equals to maximum HS-PDSCHs UE_Category supports. Otherwise, MaxNumHSPDSCH equals to NumHSPDSCH.
- If pin CQI is connected, modulation scheme and number of HS-PDSCHs practically used (EffectiveNumHSPDSCH) are determined by input CQI value and UE_Category according to Table 7 of 6A.2 in [Reference \[3\]](#). Otherwise, modulation scheme are determined by MS, and EffectiveNumHSPDSCH equals to NumHSPDSCH.
- Although $1920 \times \text{MaxNumHSPDSCH}$ tokens are consumed at each firing, only the first EffectiveNumHSPDSCH HS-PDSCHs are occupied and 0s are padded for the other HS-PDSCHs. Each HS-PDSCHs contains 1920 bits. If modulation scheme is QPSK, only the first 960 bits are useful data bits, and the other 960 bits are 0s. If modulation scheme is 16QAM, all 1920 bits are useful data bits.
- For QPSK, only STTD encoding is performed on the data bits from pin DataIn as shown below.

Generic block diagram of STTD encoder for QPSK

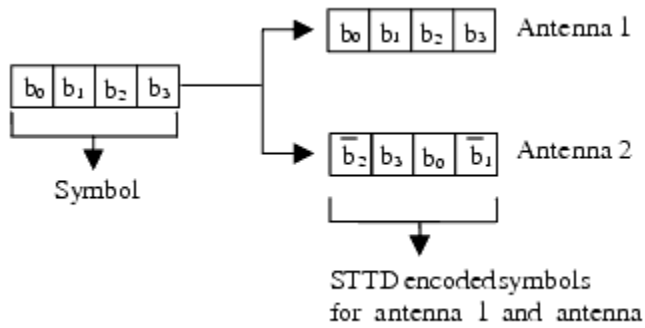

5. For 16QAM, constellation re-arrangement is first performed on the data bits from pin DataIn according to the table below. Then, STTD encoding is performed on the constellation re-arranged bits as shown below.

Constellation re-arrangement for 16QAM

constellation version parameter b	Output bit sequence	Operation
0	$v_{p,k}, v_{p,k+1}, v_{p,k+2}, v_{p,k+3}$	None
1	$v_{p,k+2}, v_{p,k+3}, v_{p,k}, v_{p,k+1}$	Swapping MSBs with LSBs
2	$v_{p,k}, v_{p,k+1}, \overline{v_{p,k+2}}, \overline{v_{p,k+3}}$	Inversion of the logical values of LSBs
3	$v_{p,k+2}, v_{p,k+3}, \overline{v_{p,k}}, \overline{v_{p,k+1}}$	Swapping MSBs with LSBs and inversion of the logical values of LSBs

Generic block diagram of STTD encoder for 16QAM

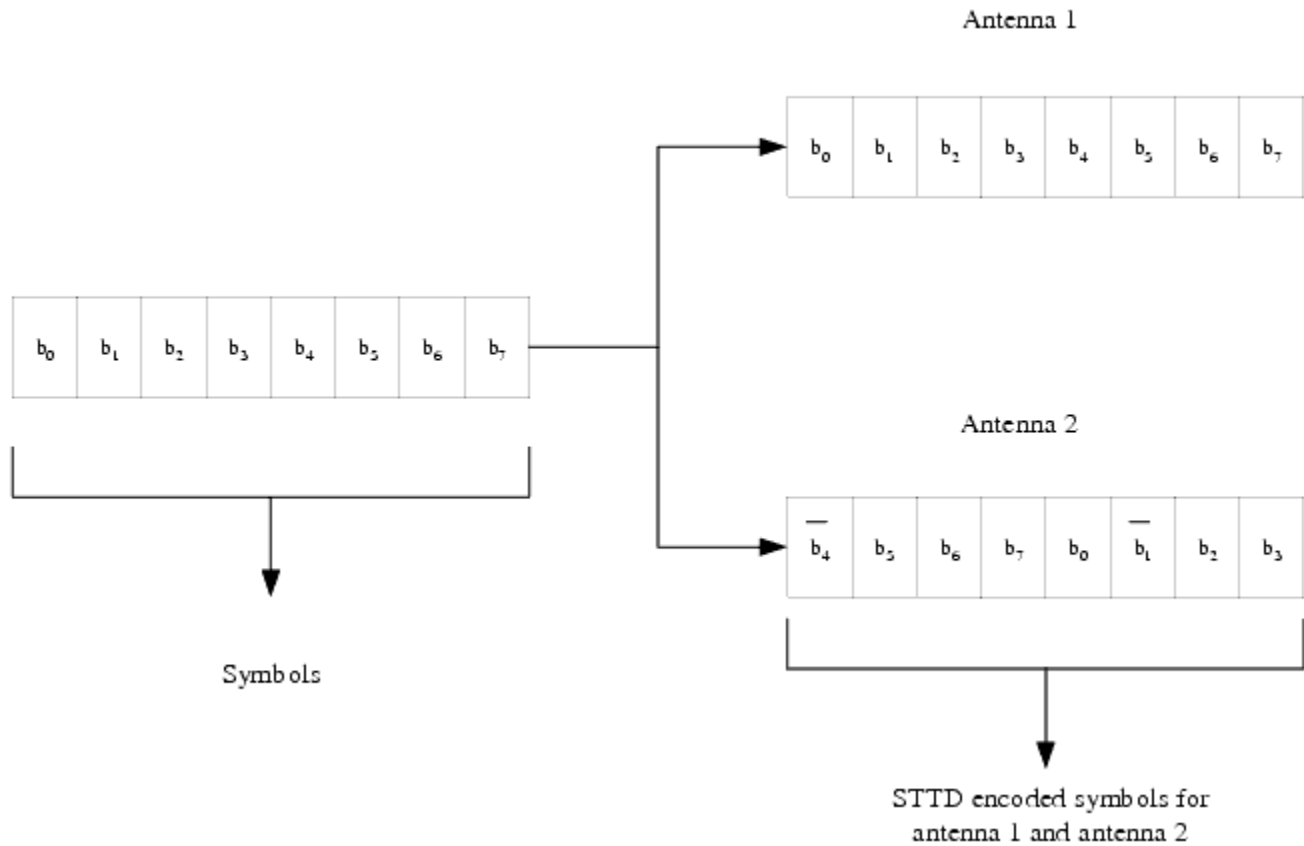

References

1. 3GPP Technical Specification TS 25.211, "Physical channels and mapping of transport channels onto physical channels (FDD)," Version 6.7.0, Dec. 2005.
2. 3GPP Technical Specification TS 25.212, "Multiplexing and channel coding (FDD)," Version 6.7.0, Dec. 2005.
3. 3GPP Technical Specification TS 25.214, "Physical layer procedures (FDD)," Version 6.7.1, Dec. 2005.

HSDPA_Throughput

HSDPA throughput calculator

Symbol

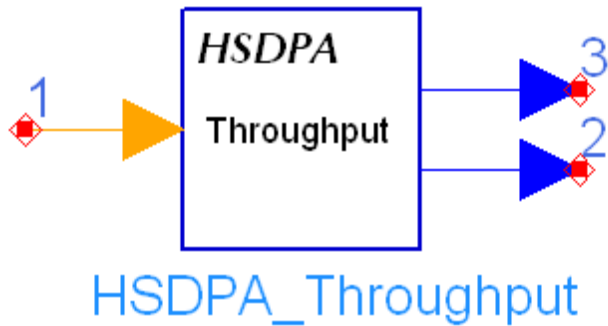

Description: HSDPA throughput calculator

Library: HSDPA, Measurement

Class: SDFHSDPA_Throughput

Parameters

Name	Description	Default	Type	Range
TTIPattern	inter-TTI pattern	{1, 1, 1, 1, 1, 1}	int array	[0, 1]
TransBlockSize	Transport block size	3202	int	[1, 27952]
TransBlockIgnored	Transport block Ignored due to system delay	1	int	[0, 5]

Pin Inputs

Pin	Name	Description	Signal Type
1	Parity	CRC result of received bits	int

Pin Outputs

Pin	Name	Description	Signal Type
2	R	throughput in kbps	real
3	R_Pct	throughput in percent	real

Notes/Equations

1. This model is used to estimate throughput of HSDPA downlink.
2. The TransBlockSize parameter determines the transport block size of HS-DSCH. The largest transport block size is 27,952 bits, which corresponds to the highest data rate of 13.976 Mb/s (27,952 bits/2 ms = 13.976 Mb/s). This data rate is obtained by using 16 QAM, an effective code rate of 0.9714, and 15 HS-PDSCHs.
3. R_Pct is the number of valid TTIs with Parity=1 divided by the total number of Parity in valid TTIs. R is the throughput in kbps: $R=R_Pct*TransBlockSize/2$.

References

1. 3GPP Technical Specification TS 25.212, "Multiplexing and channel coding (FDD)," Version 6.7.0, Dec. 2005.

HSDPA Base Station Transmitter Design Examples

The HSDPA_BS_Tx_prj project shows base station transmitter measurement characteristics including maximum output power, occupied bandwidth, complementary cumulative distribution function (CCDF), spectrum emission, adjacent channel leakage power ratio (ACLR), EVM and peak code domain error and code domain power measurement. The downlink frequency band is set at 2110 to 2170 MHz and the signal sources are the test models defined in 25.141.

Designs for these measurements include:

- Maximum power measurements: BS_Tx_MaxPower.dsn
- Occupied bandwidth measurements: BS_Tx_OccupiedBW.dsn
- Complementary cumulative distribution function measurements: BS_Tx_CCDF.dsn
- Transmitter spectrum emissions measurements: BS_Tx_Spec_Emission.dsn
- Adjacent channel leakage power measurements in frequency domain: BS_Tx_ACLR.dsn
- Transmitter EVM measurements: BS_Tx_EVM.dsn
- Transmitter peak code domain error measurements: BS_Tx_Pk_Code_Error.dsn
- Connect with VSA 89600 software and show the results of VSA 89600 software: BS_Tx_VSA.dsn

Variables used in these designs are listed in the following table.

VAR Parameters

Parameter Name	Description	Default Value
SamplePerChip	Samples per chip	8

ChipsPerSlot	Chips per slot	2560
NumSlotMeasured	Number of slots to be measured	Depends on measurements
StartSlot	The first slot to be measured	0
TimeStart	Start point for timed measurement	$(1 + \text{StartSlot}) * 667e-6$
TimeStep	Time step	$1 / (3840000 * \text{SamplesPerChip})$
TimeStop	Stop point for timed measurement	$(1 + \text{StartSlot} + \text{NumSlotMeasured}) * 667e-6$
FilterLength	Filter length in terms of samples	16
RF_Freq	RF frequency	2140 (MHz)
SignalPower	Signal power	Depends on measurement

Maximum Power Measurements

BS_Tx_MaxPower.dsn design

Features

- maximum power measurement
- HSDPA signal or test model 1 can be used as the signal source
- synchronized slot measurement

Description

BS_Tx_MaxPower.dsn measures the maximum power of downlink signal. Normally, the base station maximum output power must remain within +2dB and -2dB of the manufacturer's rated power.

The schematic for this design is shown below.

BS_Tx_MaxPower.dsn Schematic

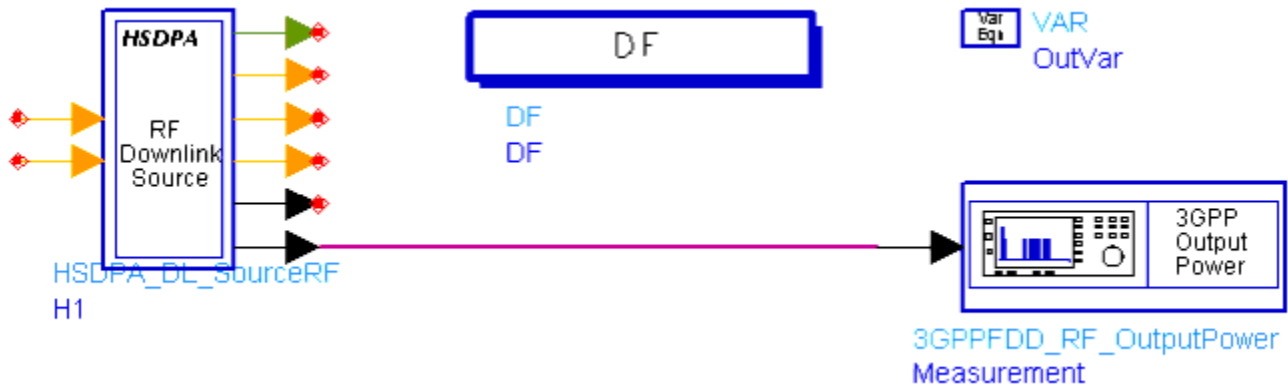

HSDPA_DL_SourceRF can output 3GPP TestModel1 signal. This signal consists of 16/32/64 DPCH channels, one PICH channel, one primary CPICH channel and one PCPCH+SCH channel. The PICH channel and DPCH channels are transmitted after different time offsets. When OutputMode = Ramp, the output power will reach its preset value after all channels are transmitted. Meaningful maximum power is reached after 15 slots.

3GPPFDD_RF_OutputPower measures the average power of the specified slots. The average period is one slot; SlotNum specifies the number of slots to be measured. Test signals are aligned at the specified slot boundary to ensure that the power average is based on a single slot.

Simulation Results

The figure below shows the performance of maximum output power.

Maximum Power Curve

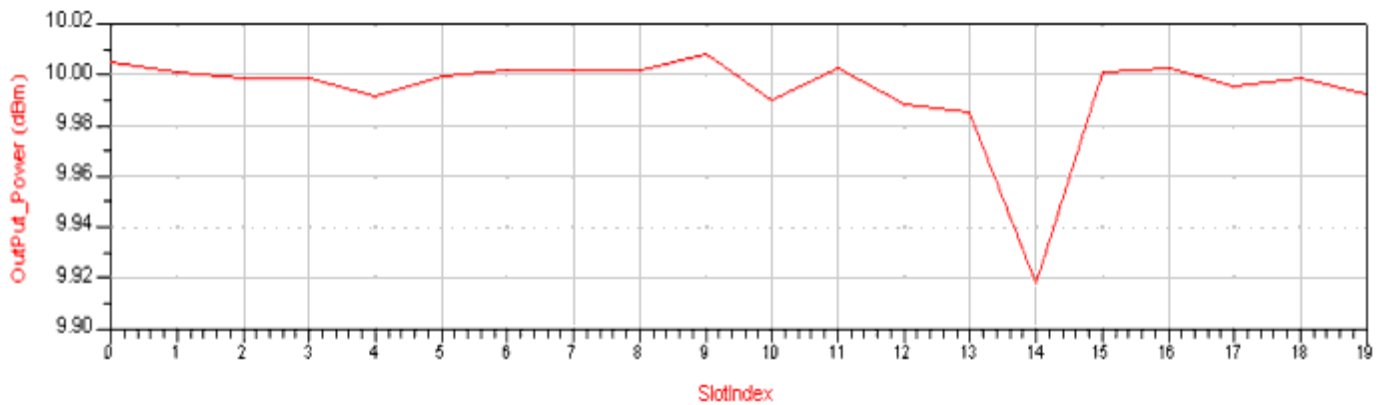

Benchmark

- Hardware Platform: Pentium IV 2.2GHz, 1 GB memory
- Software Platform: Windows 2000, ADS 2005A
- Data Points: 20 slots
- Simulation Time: approximately 16 seconds

Occupied Bandwidth Measurements

Occupied Bandwidth Measurements

BS_Tx_OccupiedBW.dsn Design

Features

- occupied bandwidth measurement
- HSDPA signal or test model 1 can be used as the signal source
- synchronized slot measurement

Description

BS_Tx_OccupiedBW.dsn measures the occupied bandwidth of downlink signal. The schematic is shown below.

Occupied bandwidth is a measure of the bandwidth containing 99% of the integrated power for the transmitted spectrum and is centered on the assigned frequency. The occupied bandwidth must be less than 5 MHz based on a chip rate of 3.84 Mcps.

BS_Tx_OccupiedBW.dsn Schematic

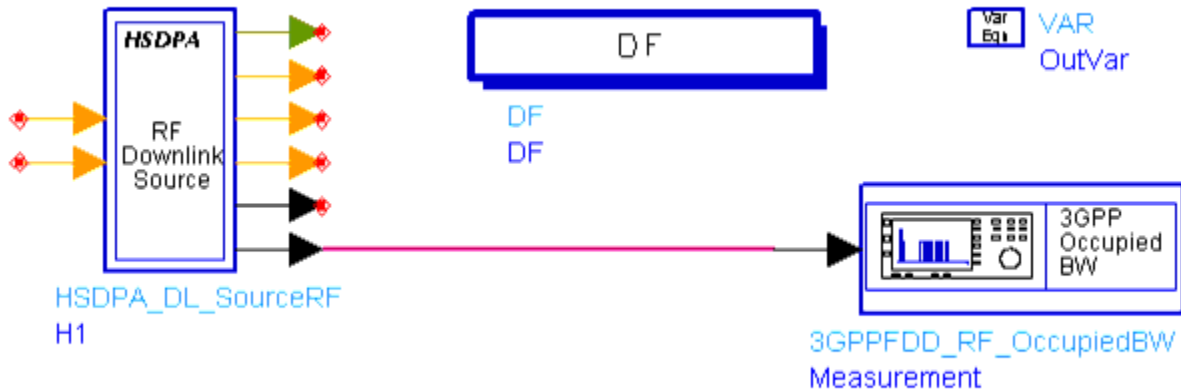

HSDPA_DL_SourceRF can output 3GPP TestModel1 signal. This signal consists of 16/32/64 DPCH channels, one PICH channel, one primary CPICH channel and one PCPCH+SCH channel. The PICH channel and DPCH channels are transmitted after different time offsets. When OutputMode = Ramp, the output power will reach its preset value after all channels are transmitted. Meaningful maximum power is reached after 15 slots.

Carrier frequency is set to 2140 MHz in this design.

Simulation Results

The signal power density spectrum is obtained using the spectrum analyzer. The figure below shows the signal power density spectrum. A marker is placed to identify the occupied bandwidth.

Occupied Bandwidth Curve

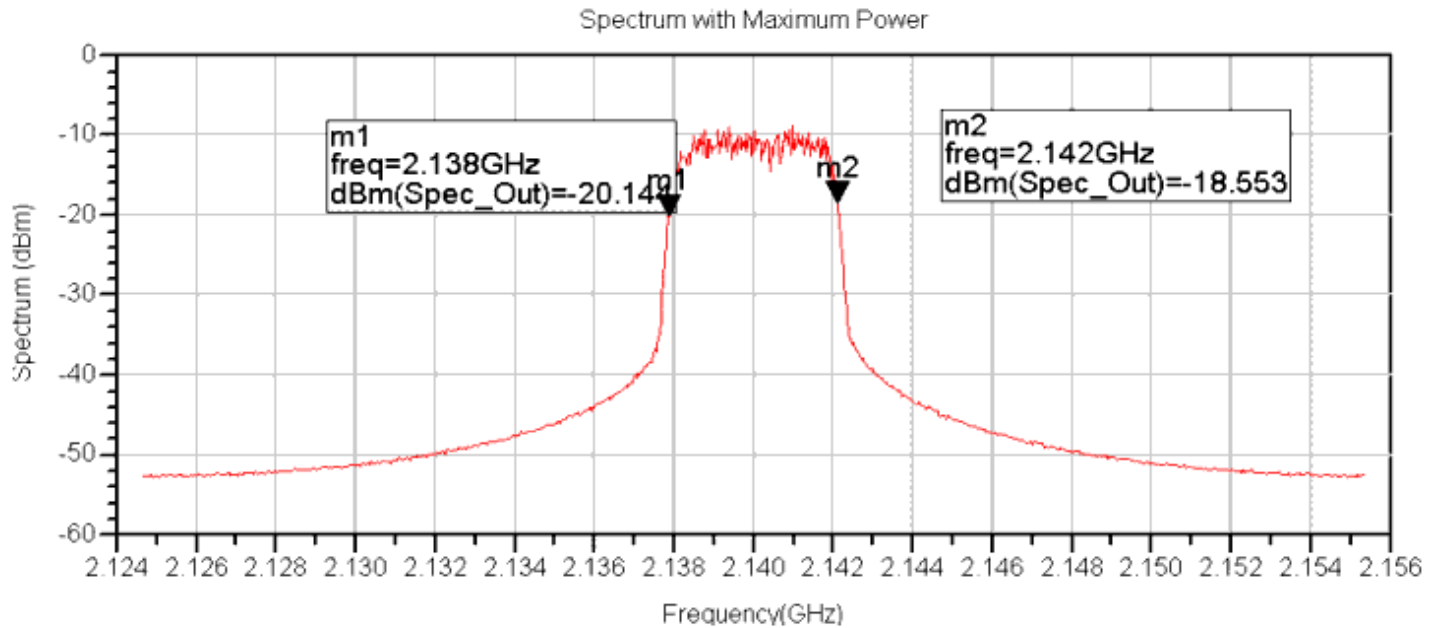

Benchmark

- Hardware Platform: Pentium IV 2.2GHz, 1 GB memory
- Software Platform: Window 2000, ADS 2005A
- Data Points: 1 slot
- Simulation Time: 8 seconds

Complementary Cumulative Distribution Function Measurements

BS_Tx_CCDF.dsn Design

Features

- CCDF measurement
- HSDPA signal or test model 1 can be used as the signal source
- synchronized slot measurement

Description

BS_Tx_CCDF.dsn measures the CCDF of a downlink signal. The schematic is shown below.

BS_Tx_CCDF.dsn Schematic

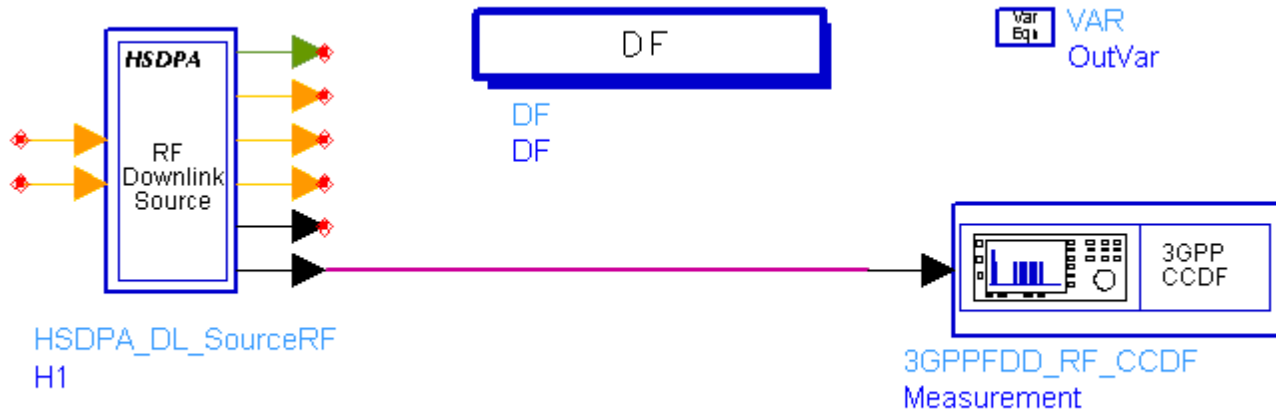

HSDPA_DL_SourceRF can output 3GPP TestModel1 signal. This signal consists of 16/32/64 DPCH channels, one PICH channel, one primary CPICH channel and one PCPCH+SCH channel. The PICH channel and DPCH channels are transmitted after different time offsets. When OutputMode = Ramp, the output power will reach its preset value after all channels are transmitted. Meaningful maximum power is reached after 15 slots.

Carrier frequency is set to 2140 MHz in this design.

Simulation Results

The measurement is deployed on 5 slots of a stable signal. The figure below shows the CCDF performance.

Base Station Transmitter CCDF Curve

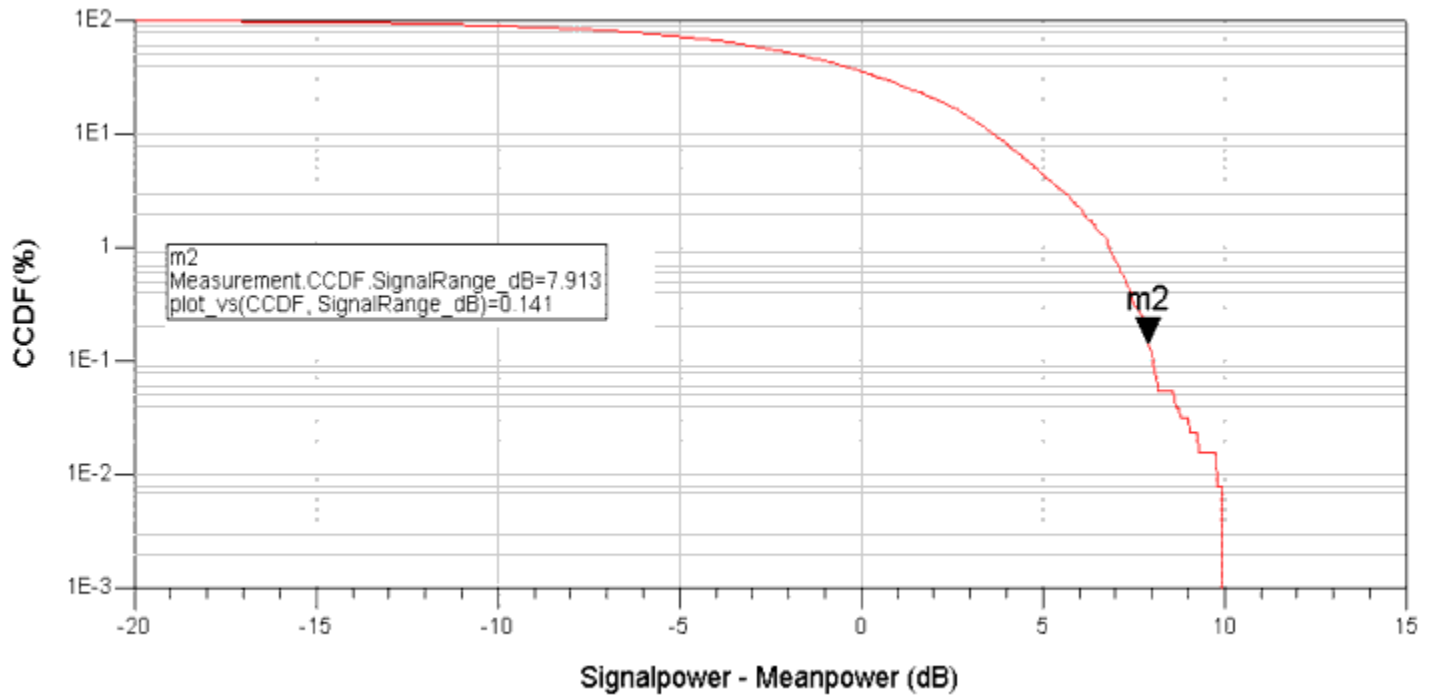

Benchmark

- Hardware Platform: Pentium IV 2.2GHz, 1 GB memory
- Software Platform: Window 2000, ADS 2005A
- Data Points: 5 slots
- Simulation Time: 8 seconds

Transmitter Spectrum Emissions Measurements

BS_Tx_Spec_Emission.dsn Design

Feature

- HSDPA signal or test model 1 can be used as the signal source
- Out-of-band power is measured by sweeping the center frequency of the band-pass filter

Description

BS_Tx_Spec_Emission.dsn measures the base station transmitter spectrum emission. Out-of-band emissions are unwanted emissions immediately outside the channel bandwidth resulting from the modulation process and non-linearity in the transmitter. The figure below shows the schematic for this design.

BS_Tx_Spec_Emission.dsn Schematic

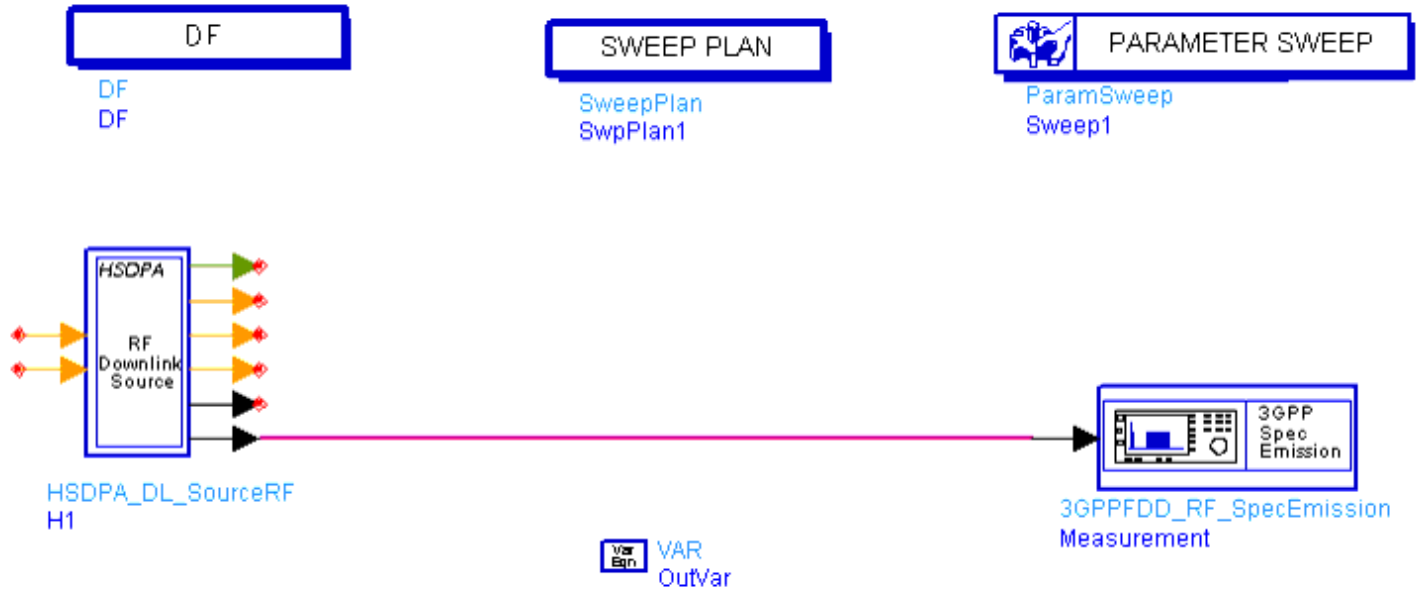

Notes

Emissions must not exceed the maximum level specified by the mask in the frequency range with offset from Δf min -12.5 MHz to Δf max 12.5 MHz from the carrier frequency. Mask values are specified in the table below. A sweeper is used to simulate all frequency offsets.

Spectrum Emission Mask Values

Frequency Offset Δf	Maximum Level	Measurement Bandwidth
Base Station Maximum Output Power P < 31 dBm		
$2.5 \leq \Delta f < 2.7$ MHz	-22 dBm	30 kHz †
$2.7 \leq \Delta f < 3.5$ MHz	$-22 - 15(\Delta f - 2.7)$ dBm	30 kHz †
$3.5 \leq \Delta f < 7.5$ MHz	-21 dBm	1 MHz ††

Advanced Design System 2008

$7.5 \leq \Delta f \leq \Delta f_{\sim\max\sim}$ MHz	-25 dBm	1 MHz ††
Base Station Maximum Output Power $31 \leq P < 39$ dBm		
$2.5 \leq \Delta f < 2.7$ MHz	P - 53 dBm	30 kHz †
$2.7 \leq \Delta f < 3.5$ MHz	P - 53 - 15(Δf - 2.7) dBm	30 kHz †
$3.5 \leq \Delta f < 7.5$ MHz	P - 52 dBm	1 MHz ††
$7.5 \leq \Delta f \leq \Delta f_{\sim\max\sim}$ MHz	P - 56 dBm	1 MHz ††
Base Station Maximum Output Power $39 \leq P < 43$ dBm		
$2.5 \leq \Delta f < 2.7$ MHz	-14 dBm	30 kHz †
$2.7 \leq \Delta f < 3.5$ MHz	-14 - 15(Δf - 2.7) dBm	30 kHz †
$3.5 \leq \Delta f < 7.5$ MHz	-13 dBm	1 MHz ††
$7.5 \leq \Delta f \leq \Delta f_{\max}$ MHz	P - 56 dBm	1 MHz ††
Base Station Maximum Output Power $P \geq 43$ dBm		
$2.5 \leq \Delta f < 2.7$ MHz	-14 dBm	30 kHz †
$2.7 \leq \Delta f < 3.5$ MHz	- 14 - 15(Δf - 2.7) dBm	30 kHz †
$3.5 \leq \Delta f \leq \Delta f_{\sim\max\sim}$ MHz	-13 dBm	1 MHz ††
† The first and last measurement positions with a 30 kHz filter are 2.515 and 3.485 MHz, respectively. † † The first and last measurement positions with a 2 MHz filter are 4 MHz and (Δf_{\max} - 500 kHz), respectively.		

Simulation Results

The spectrum emission is stored in the sink after 15 slots. The figure below shows the spectrum emission for the base station output powers listed in the table on [Spectrum Emission Mask Values](#).

Spectrum Emission Curves

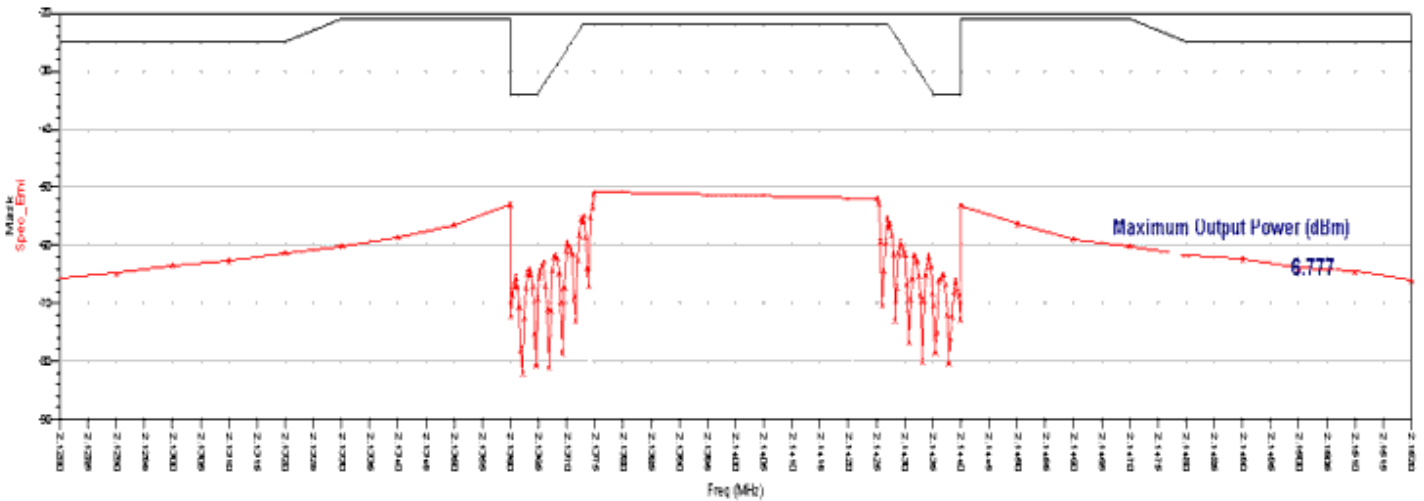

Benchmark

- Hardware Platform: Pentium IV 2.2GHz, 1 GB memory
- Software Platform: Windows 2000, ADS 2005A
- Data Points: 1slot sweeping frequency offset from -12.5 MHz to 12.5 MHz
- Simulation Time: approximately 2 hours

Adjacent Channel Leakage Power Measurements in Frequency Domain

BS_Tx_ACLR.dsn Design

Features

- adjacent channel leakage power ratio measured in the frequency domain
- HSDPA signal or test model 1 can be used as the signal source
- synchronized slot measurement

Description

BS_Tx_ACLR.dsn measures the base station transmitter adjacent channel leakage power ratio (ACLR) in the frequency domain. ACLR is the ratio of the transmitted power to the power measured after a receiver filter in the adjacent

channel. In this design, both the transmitted and received power are measured through a root raised-cosine and roll-off 0.22 matched filter; noise power bandwidth is set to 3.84 MHz. The schematic for this design is shown below.

BS_Tx_ACLR.dsn Schematic

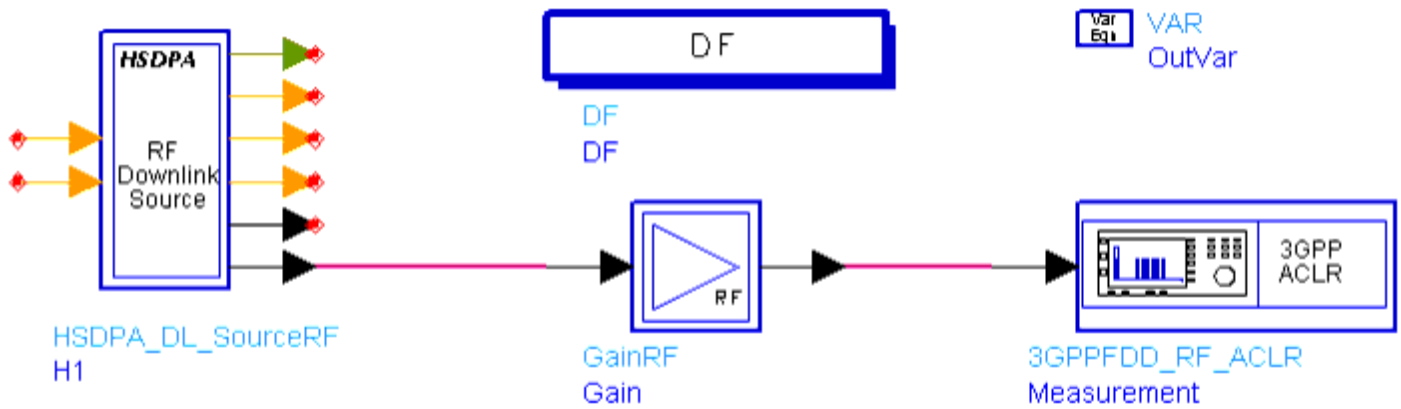

The BS_Tx_ACLR_FilterBank subnetwork used in this project is shown below; it consists of 5 root raised-cosine matched filters; the center frequencies of these filters are set to 2140 MHz with offsets of +5, +10, -5, and -10 MHz.

3GPPFDD_RF_ACLR Schematic

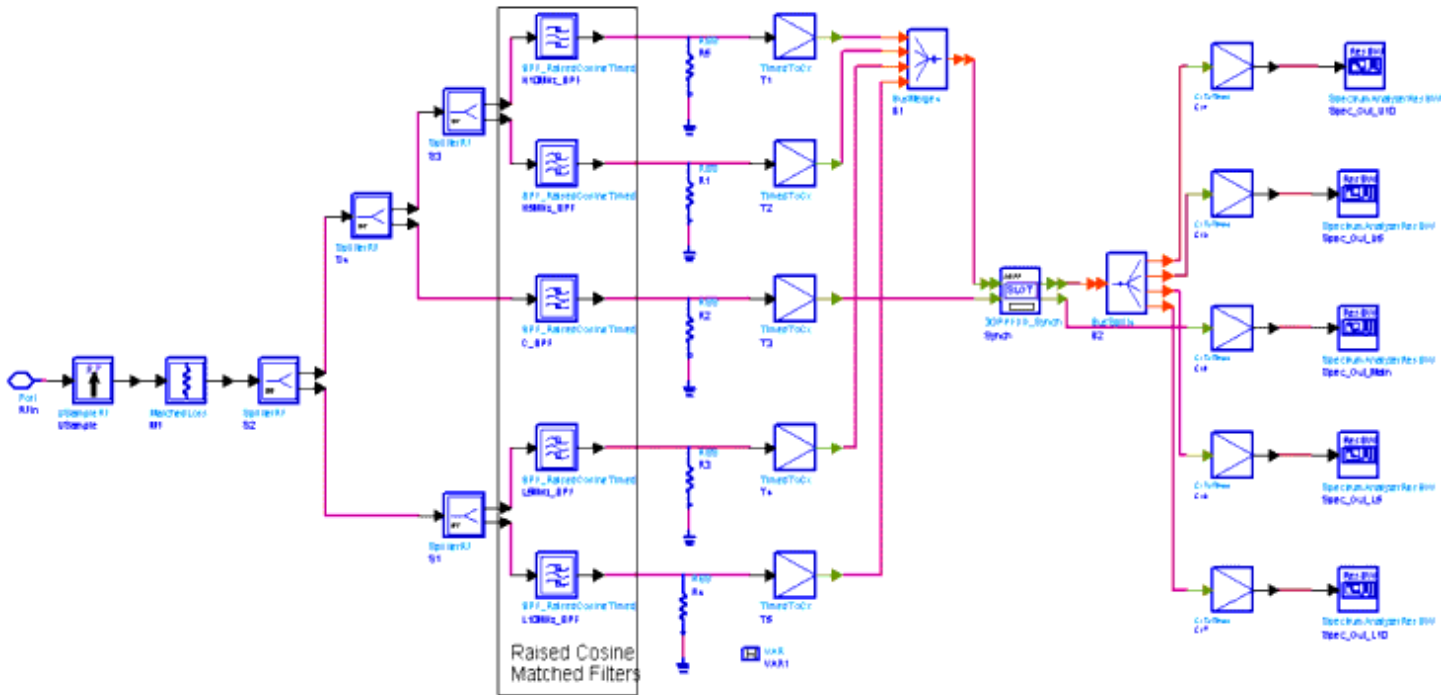

Simulation Results

The Spectrum analyzer is used to measure the transmitted power and adjacent channel power in the frequency domain. When the base station adjacent channel offset is +5 or -5 MHz, the ACLR limit is 45 dB; when the base station adjacent channel offset is +10 or -10 MHz, the ACLR limit is 50 dB. The measurement is deployed after the first frame (15 slots) and the signal becomes stable. The figure below shows the ACLR performance of the base station transmitter.

Base Station Transmitter Spectrum and ACLR Performance

3GPP FDD ACLR Measurement ACLR: Adjacent Channel Leakage power Ratio

real(FCarrier)/(1 MHz)	real(SignalPower_dBm)	real(SourceR)
2140.000	10.000	50.000

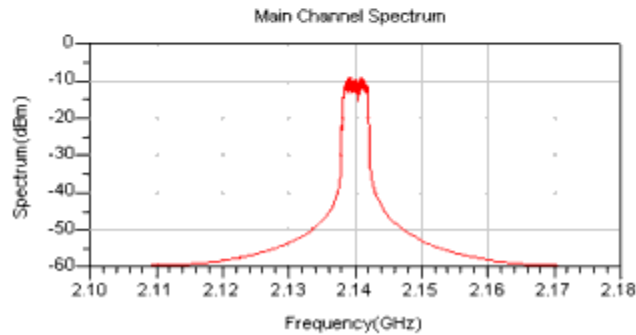
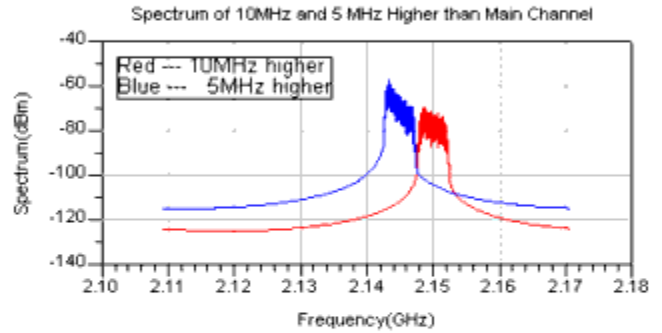
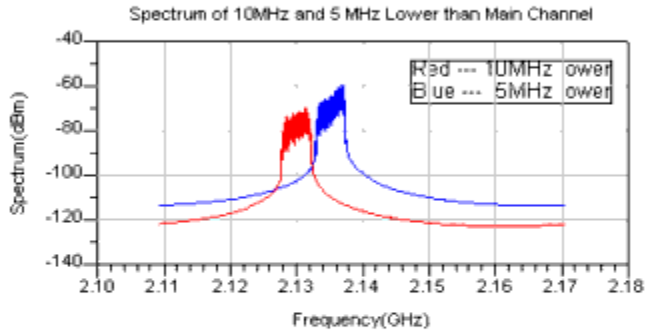

Benchmark

- Hardware Platform: Pentium IV 2.2GHz, 1 GB memory
- Software Platform: Window 2000, ADS 2005A
- Data Points: 1 slot
- Simulation Time: approximately 26 seconds

Transmitter EVM Measurements

BS_Tx_EVM.dsn Design

Features

Advanced Design System 2008

- error vector magnitude measurements
- test model 5 is used as the signal source

Description

This design measures the error vector magnitude (EVM) of the base station transmitter. EVM is the difference between the measured waveform and the theoretical modulated waveform and shows modulation accuracy. According to the Specification TS 25.104 (2005-12), the Error Vector Magnitude shall not be worse than 17.5% when the base station is transmitting a composite signal using only QPSK modulation. The Error Vector Magnitude shall not be worse than 12.5% when the base station is transmitting a composite signal that includes 16QAM modulation.

The schematic for this design is shown below.

BS_Tx_EVM.dsn Schematic

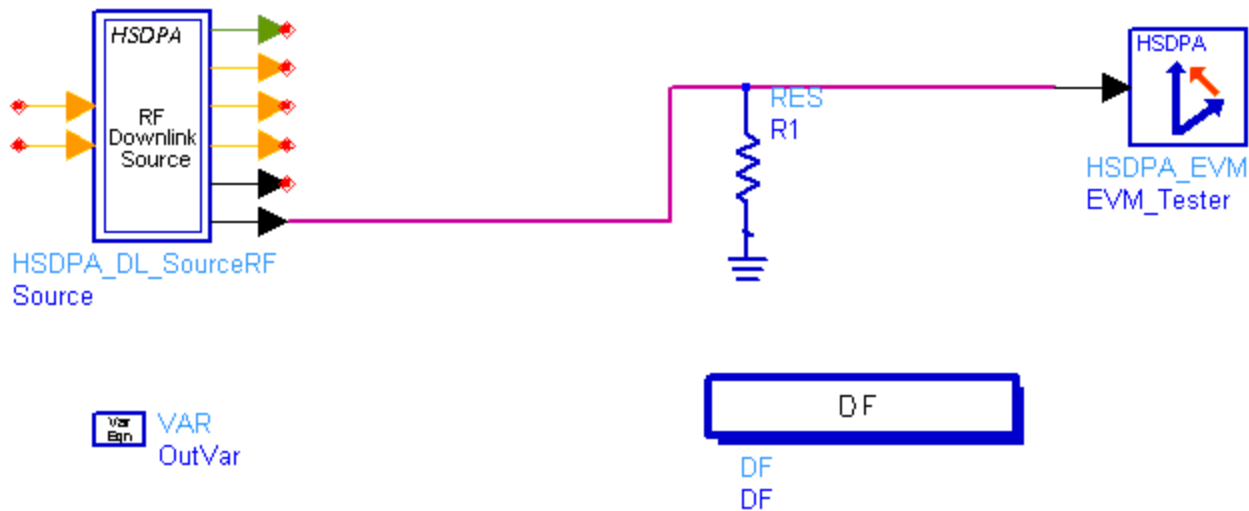

Simulation Results

The EVM result is shown below.

EVM measurement

Composite Error Summary

EVM_rms_percent (%)	MagErr_rms_percent (%)	PhaseErr_deg
0.263	0.183	0.286
FreqErr_Hz	IQOffset_dB	Rho
0.222	-88.140	1.000

Channel Error Summary

AnalysisCodeLevel	AnalysisCodeIndex	
<input type="text" value="4"/>	<input type="text" value="4"/>	
Channel_EVM (%)	Channel_MagErr_rms_percent (%)	Channel_PhaseErr_deg
4.215	2.017	2.876

Benchmark

- Hardware Platform: Pentium IV 2.26 GHz, 1 GB memory
- Software Platform: Windows 2000, ADS 2005A
- Data Points: 1 slot
- Simulation Time: approximately 13 seconds.

Transmitter Peak Code Domain Error Measurements

BS_Tx_Pk_Code_Error.dsn Design

Features

- peak code domain error calculation
- HSDPA signal or test model 3 can be used as the signal source

- synchronized slot measurement with reference signal

Description

The schematic for this design is shown below. The code domain error is calculated by projecting the error vector power onto the code domain at the maximum spreading code. The measurement is implemented by the 3GPPFDD_RF_PCDE subnetwork shown in the [3GPPFDD_RF_PCDE.dsn Schematic](#). The peak code domain error is defined as the maximum value for the code domain error and cannot exceed -33 dB.

BS_Tx_Pk_Code_Error.dsn Schematic

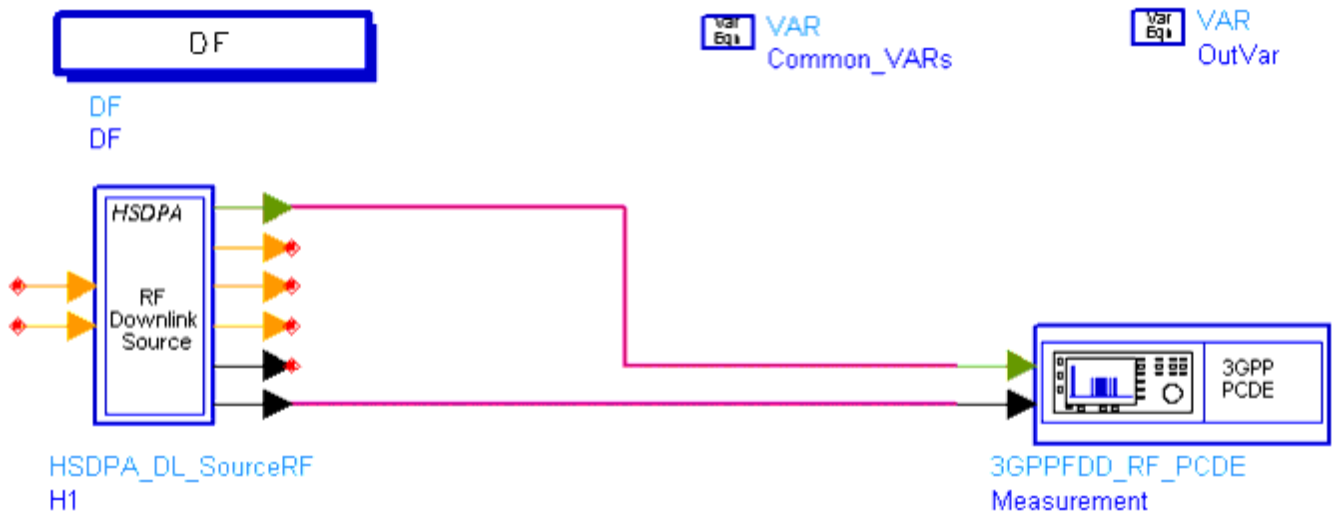

3GPPFDD_RF_PCDE.dsn Schematic

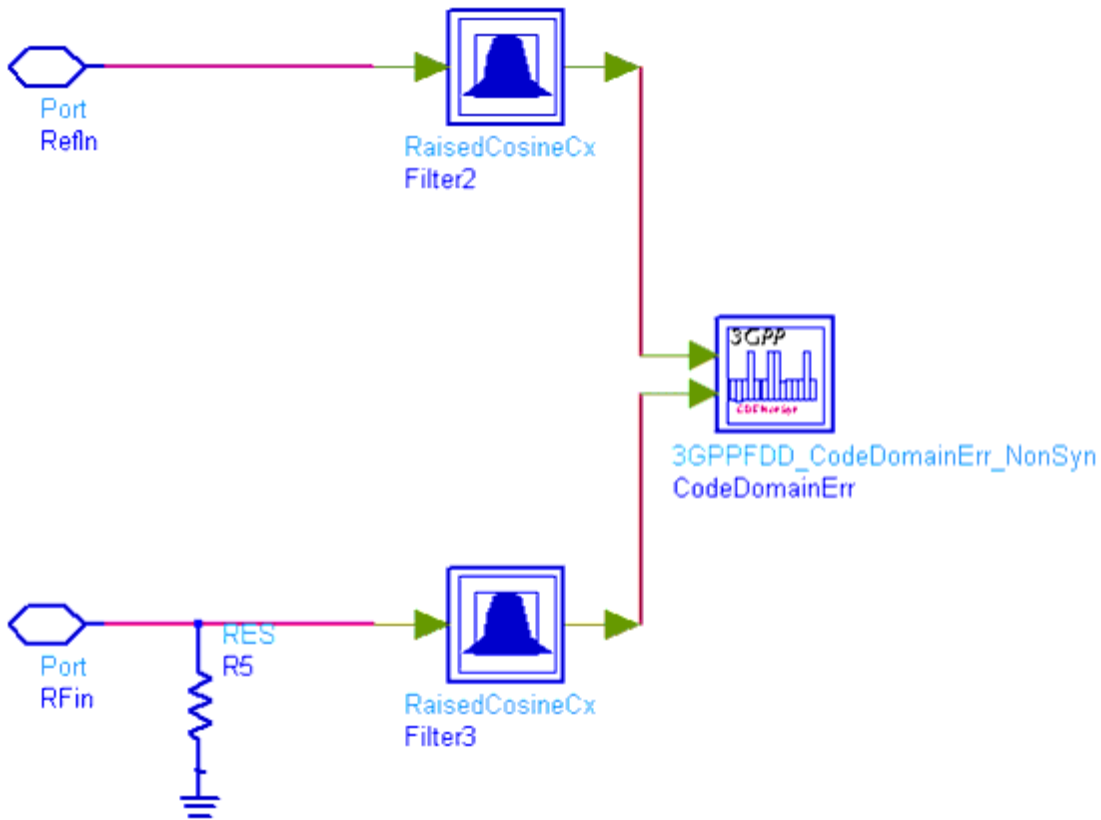

Simulation Results

The peak code domain error is shown below.

Peak Code Domain Error of Base Station Transmitter

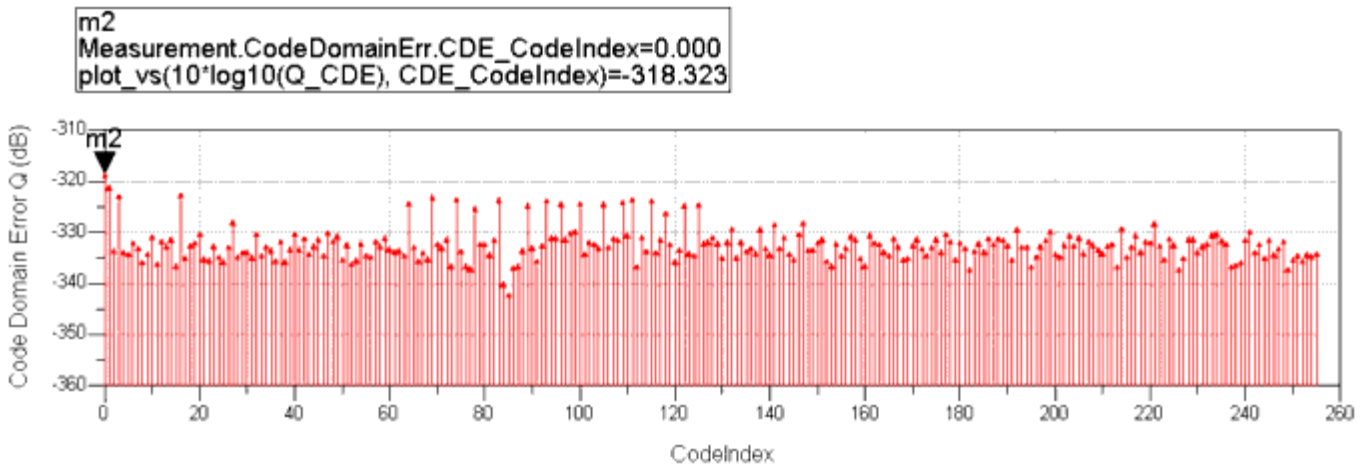
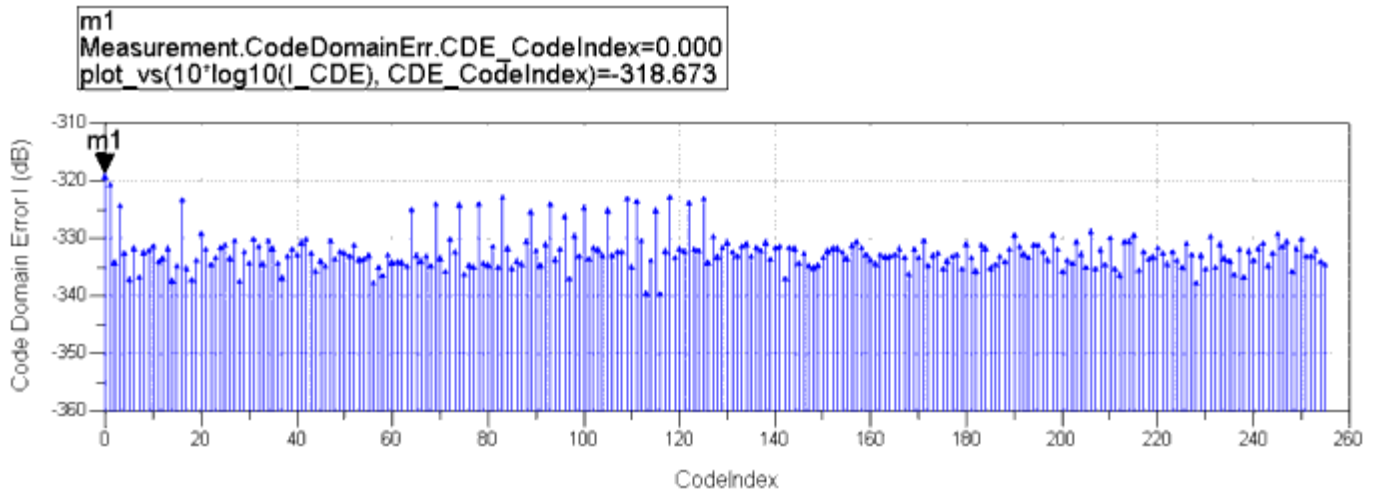

Benchmark

- Hardware Platform: Pentium IV 2.2GHz, 1 GB memory
- Software Platform: Window 2000, ADS 2005A
- Data Points: 1 slot
- Simulation Time: 34 seconds

Connection with 89600 VSA Software

BS_Tx_VSA.dsn Design

Features

- Connect with 89600 VSA software and show the results of 89600 VSA software.

Description

The schematic for this design is shown below.

BS_Tx_VSA.dsn Schematic

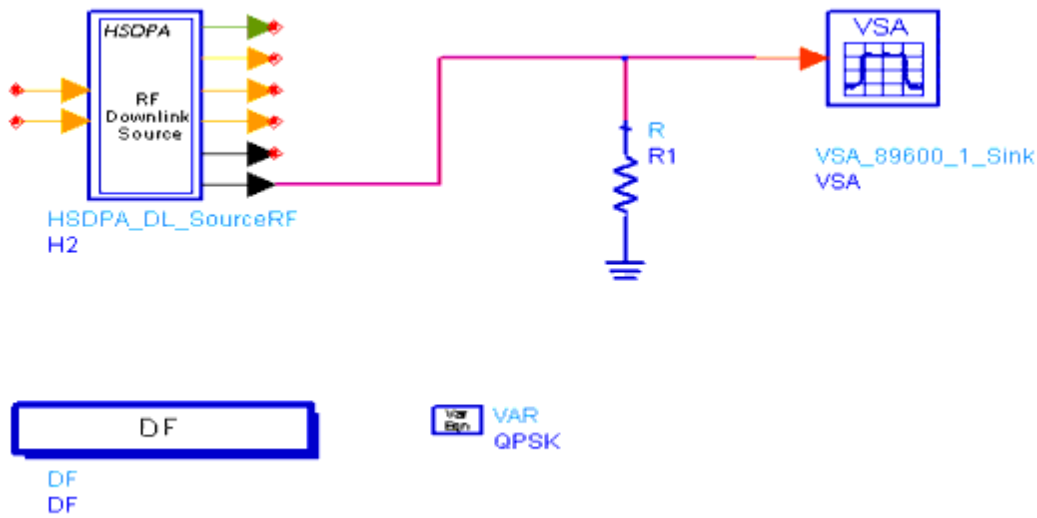

Simulation Results

The peak code domain error is shown below.

89600 VSA software results

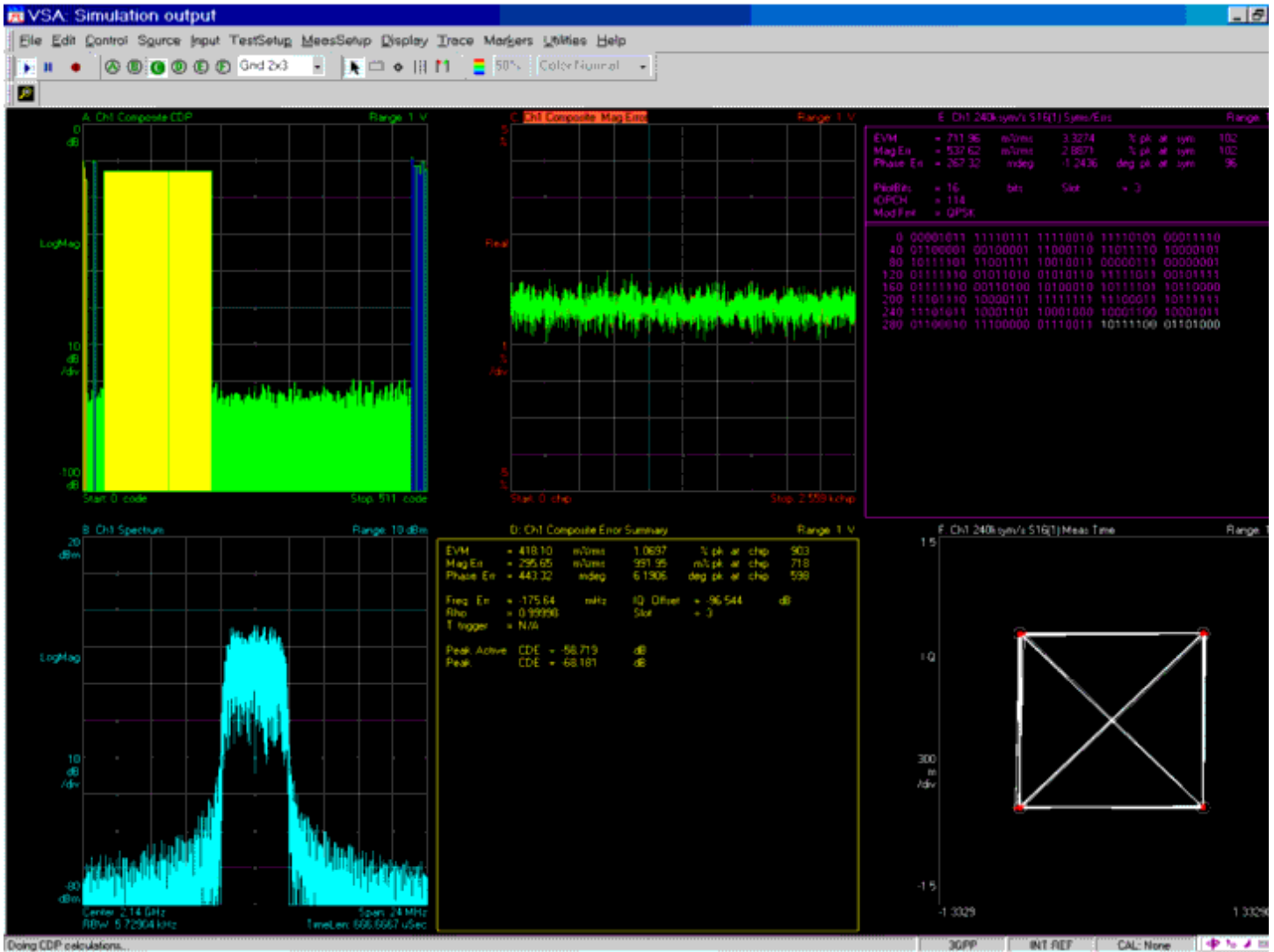

Benchmark

- Hardware Platform: Pentium IV 2.26GHz, 1 GB memory
- Software Platform: Window 2000, ADS 2005A, 89600 VSA

References

1. 3GPP Technical Specification TS 34.121 V6.3.0 "Terminal conformance Specification: Radio transmission and reception (FDD)," December 2005.
2. 3GPP Technical Specification TS 25.104 V6.11.0, "Base Station (BS) radio transmission and reception (FDD),"

December 2005.

3. 3GPP Technical Specification TS 25.141 V6.12.0, "Base station (BS) conformance testing (FDD)," December 2005.

HSDPA User Equipment Receiver Design Examples

The HSDPA_UE_Rx_prj project shows user equipment receiver measurement performances, including HS-DSCH demodulation performance, HS-SCCH signaling detection performance.

Designs for these measurements are described in the following sections; including:

- Demodulation performance:
 - UE_Rx_Demodulation_Hset1_PA3_QPSK.dsn
 - UE_Rx_Demodulation_Hset2_PB3_16QAM.dsn
 - UE_Rx_Demodulation_Hset3_VA30_16QAM.dsn
 - UE_Rx_Demodulation_Hset4_PB3_QPSK.dsn
 - UE_Rx_Demodulation_Hset5_VA120_QPSK.dsn
 - UE_Rx_Demodulation_Hset6_PA3_16QAM.dsn
 - UE_Rx_MaxLevel.dsn
- Signaling detection performance - false alarm:
 - UE_Rx_HSSCCH_Detection_TS1_PA3.dsn

Designs under this project consist of:

- Downlink RF band signal source
HSDPA_DL_SourceRF is used to provide an RF HSDPA downlink signal source.
- Fading channel
HSPA_Channel is used to provide various multi-path fading propagation conditions.
- AWGN noise
AddNDensity is used to provide AWGN in order to calibrate the system E_c/N_0 at certain levels, which are required by various performance measurements.
- User Equipment RF receiver
HSDPA_DL_ReceiverRF is used to provide a receiver of RF HSDPA downlink signals.

References

1. 3GPP Technical Specification TS 25.101, "UE Radio transmission and Reception (FDD)," Version 6.10.0, Dec. 2005.

HS-DSCH Demodulation Performance Measurement

UE_Rx_Demodulation_Hset1_PA3_QPSK.dsn
UE_Rx_Demodulation_Hset2_PB3_16QAM.dsn
UE_Rx_Demodulation_Hset3_VA30_16QAM.dsn
UE_Rx_Demodulation_Hset4_PB3_QPSK.dsn
UE_Rx_Demodulation_Hset5_VA120_QPSK.dsn
UE_Rx_Demodulation_Hset6_PA3_16QAM.dsn

Features

- Base station receiver demodulation performance measurements
- ARQ (feedback) controlled source
- Integrated RF models
- Throughput (R)
- Multiple E_c/N_0 measurement points
- Multi-path fading propagation conditions

Description

UE_Rx_Demodulation_Hset1_PA3_QPSK.dsn measures user equipment receiver HS-DSCH demodulation performance under H-Set1 FRC (Fixed Reference Channel) and PA3 channel with QPSK modulation.
UE_Rx_Demodulation_Hset2_PB3_16QAM.dsn measures user equipment receiver HS-DSCH demodulation performance under H-Set2 FRC and PB3 channel with 16QAM modulation.
UE_Rx_Demodulation_Hset3_VA30_16QAM.dsn measures user equipment receiver HS-DSCH demodulation performance under H-Set3 FRC and VA30 channel with 16QAM modulation.
UE_Rx_Demodulation_Hset4_PB3_QPSK.dsn measures user equipment receiver HS-DSCH demodulation performance under H-Set4 FRC and VA30 channel with QPSK modulation.
UE_Rx_Demodulation_Hset5_VA120_QPSK.dsn measures user equipment receiver HS-DSCH demodulation performance under H-Set5 FRC and VA120 channel with 16QAM modulation.
UE_Rx_Demodulation_Hset6_PA3_16QAM.dsn measures user equipment receiver HS-DSCH demodulation performance under H-Set6 FRC and PA3 channel with 16QAM modulation. They are all according to section 9.2 in TS 25.101.

The schematics of fading condition are shown From [UE_Rx_Demodulation_Hset1_PA3_QPSK.dsn Schematic](#) to [UE_Rx_Demodulation_Hset2_PB3_16QAM.dsn Schematic](#).

UE_Rx_Demodulation_Hset1_PA3_QPSK.dsn Schematic

UE_Rx_Demodulation_Hset1_PA3_QPSK.dsn

HSDPA: Demodulation of Hset1 under PA3



HSDPA_UE_Rx_DemodulationInfo
Push into and find more information

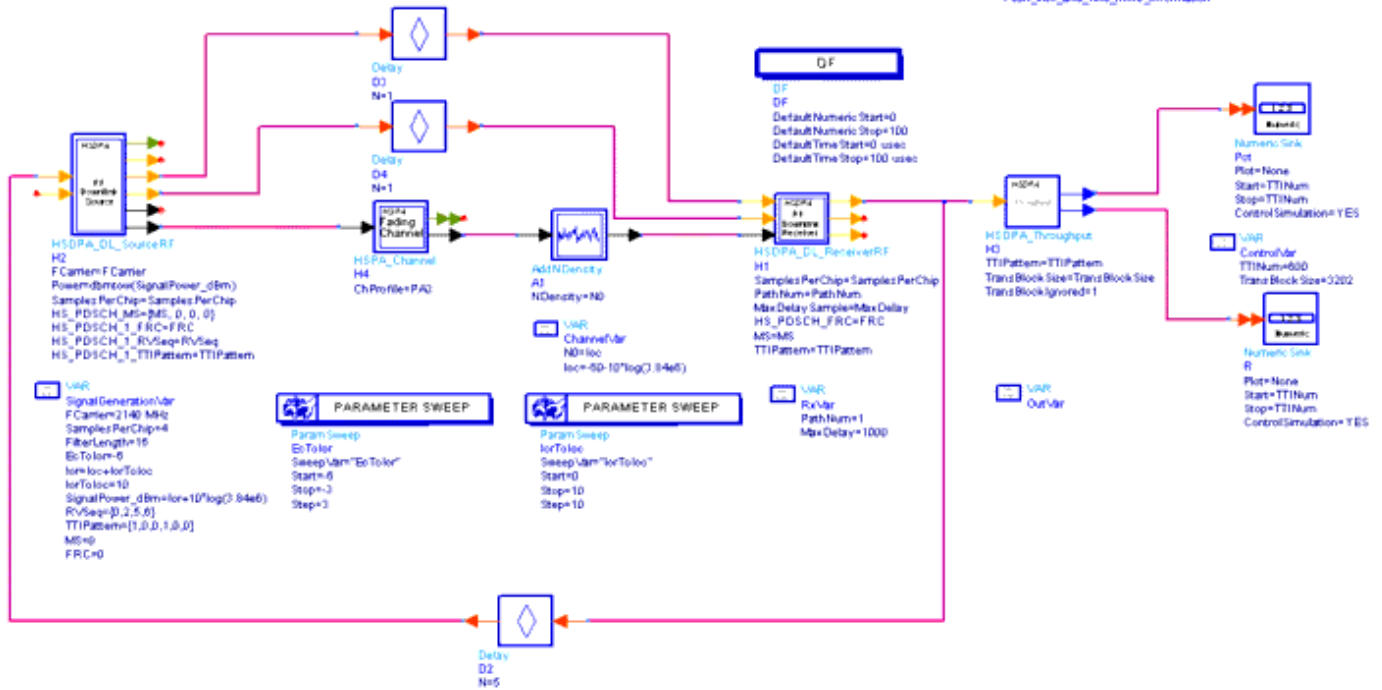

UE_Rx_Demodulation_Hset2_PB3_16QAM.dsn Schematic

UE_Rx_Demodulation_Hset2_PB3_16QAM.dsn

HSDPA: Demodulation of Hset2 under PB3

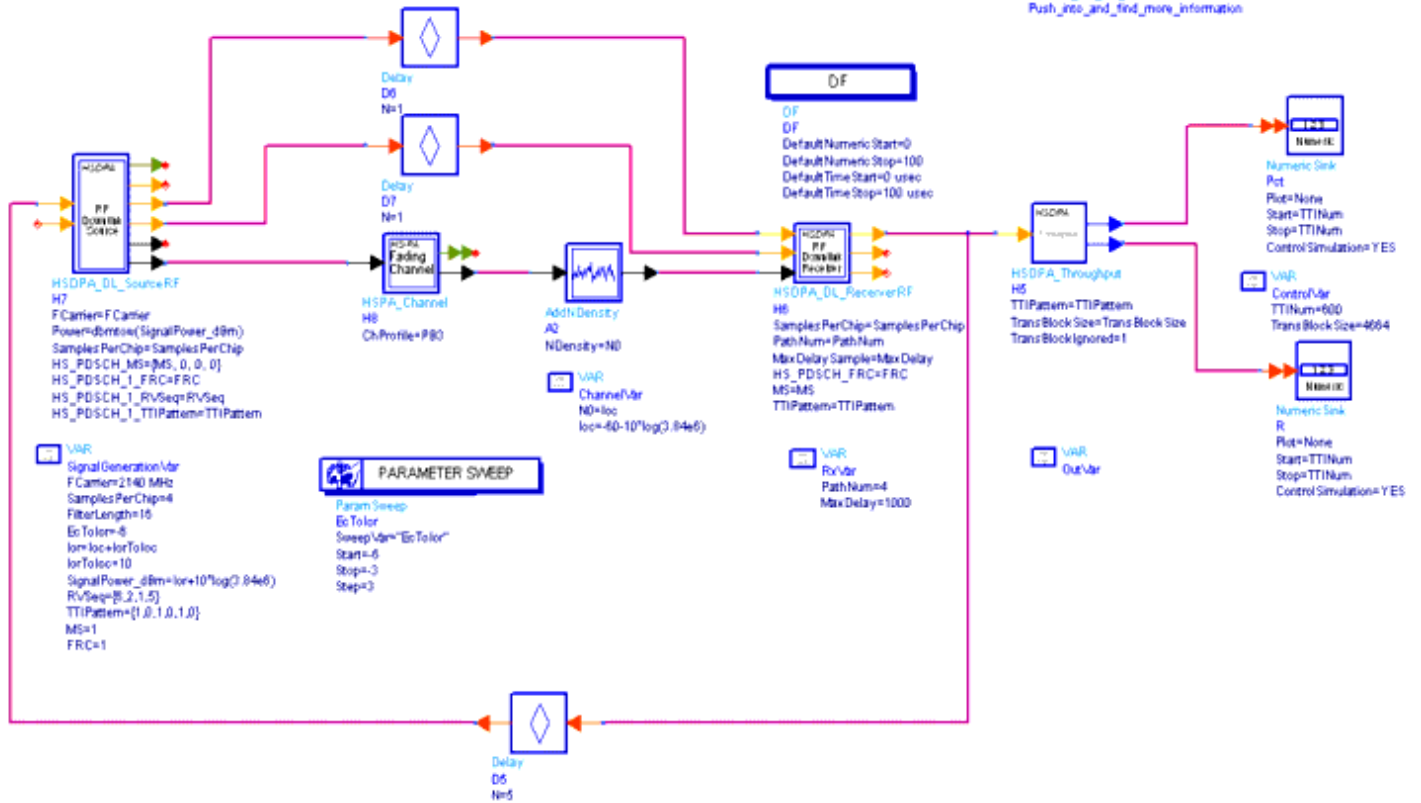

UE_Rx_Demodulation_Hset3_VA30_16QAM.dsn Schematic

UE_Rx_Demodulation_Hset3_VA30_16QAM.dsn

HSDPA: Demodulation of Hset3 under VA30

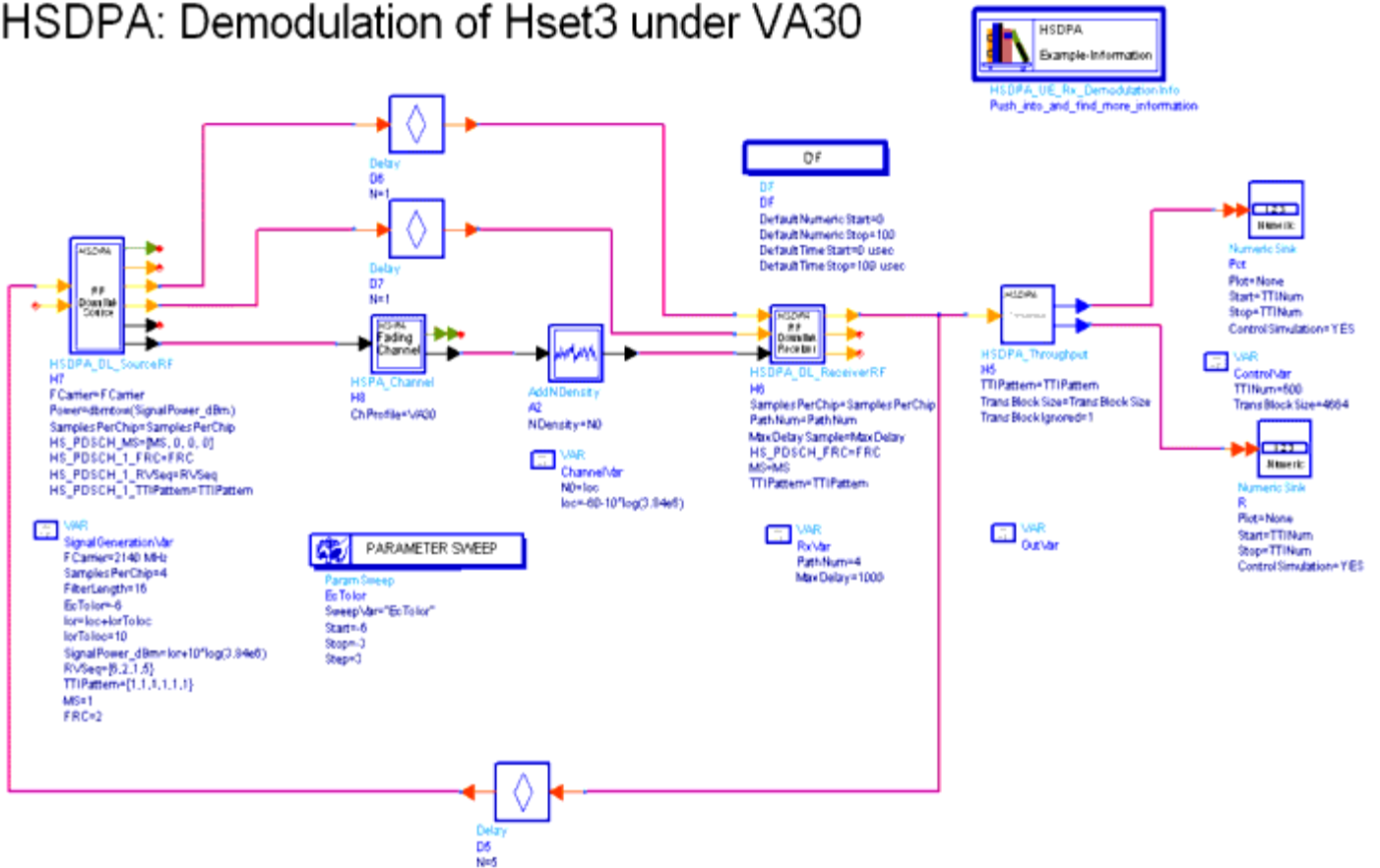

UE_Rx_Demodulation_Hset4_PB3_QPSK.dsn Schematic

UE_Rx_Demodulation_Hset4_PB3_QPSK.dsn

HSDPA: Demodulation of Hset4 under PB3



HSDPA_UE_Rx_DemodulationInfo
Push_into_and_find_more_information

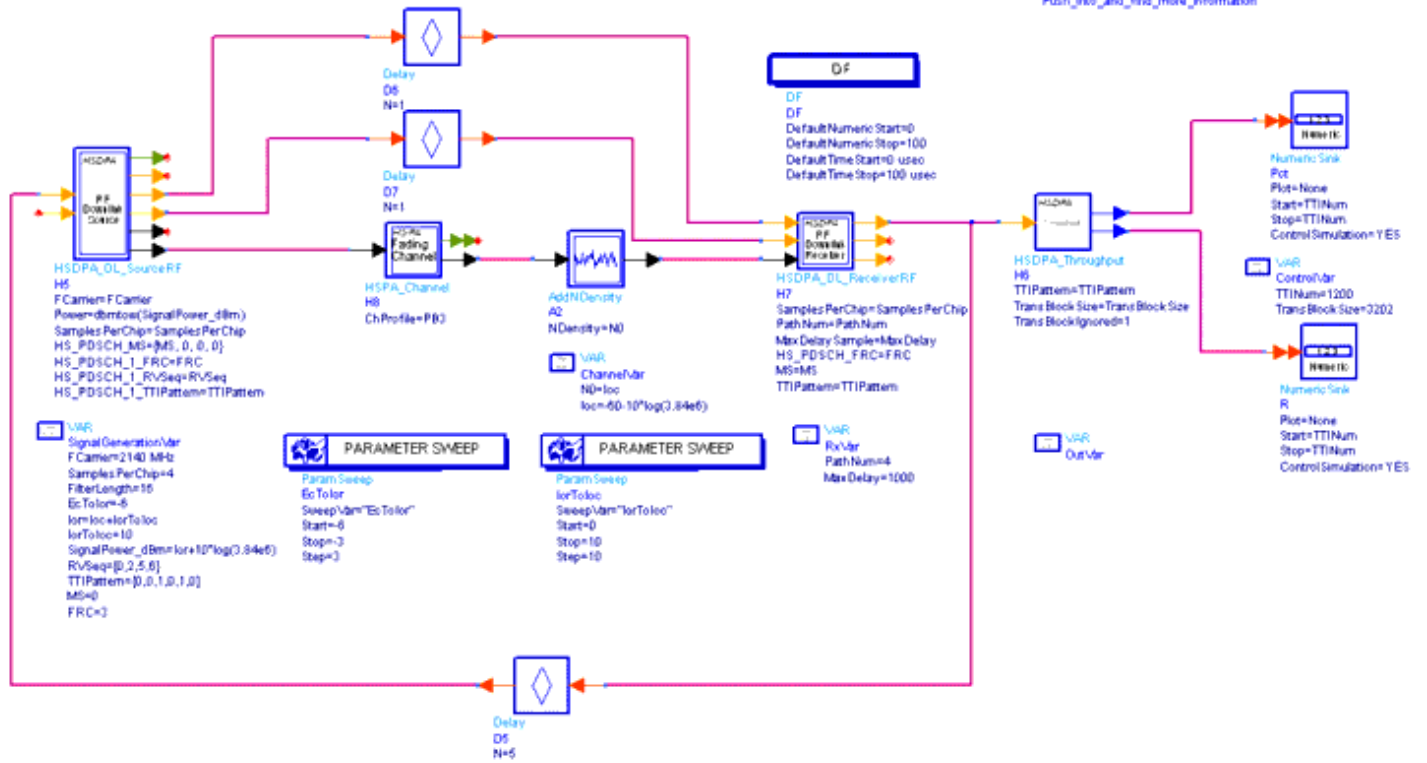

UE_Rx_Demodulation_Hset5_VA120_QPSK.dsn Schematic

UE_Rx_Demodulation_Hset6_PA3_16QAM.dsn

HSDPA: Demodulation of Hset6 under PA3

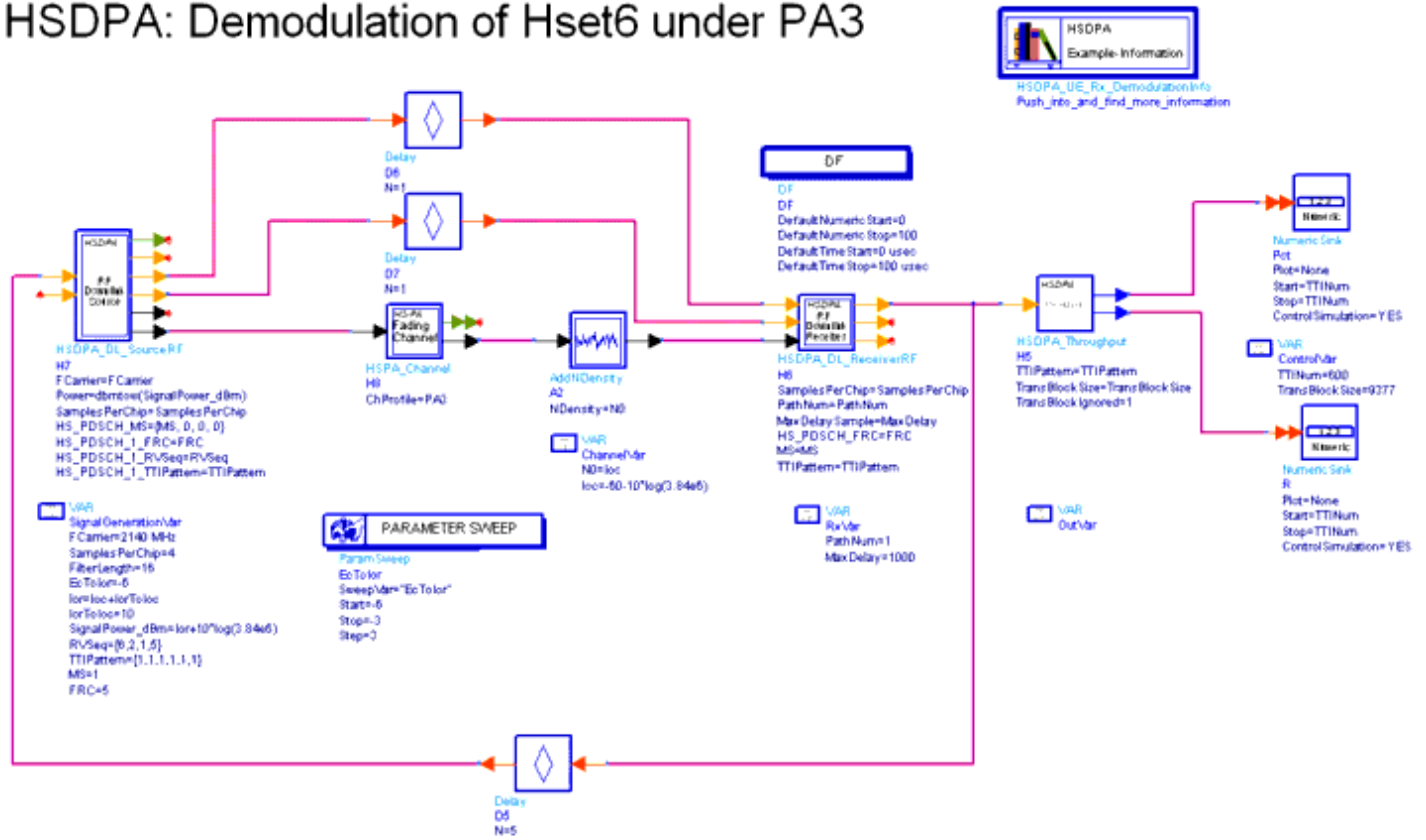

Simulation Results

Simulation results are shown in [Throughput Results \(R\) for User Equipment Demodulation Performance Measurement \(Fading\) Hset1 under PA3 channel with QPSK modulation](#) to [Throughput Results \(R\) for User Equipment Demodulation Performance Measurement \(Fading\) Hset6 under PA3 channel with 16QAM modulation](#).

Throughput Results (R) for User Equipment Demodulation Performance Measurement (Fading) Hset1 under PA3 channel with QPSK modulation

HSDPA HS-DSCH Demodulation Performance--Tables

Throughput results

Index	R	Pct
EcTolor=-6.000, IorToloc=0.000 600	98.728	0.185
EcTolor=-6.000, IorToloc=10.000 600	330.873	0.620
EcTolor=-3.000, IorToloc=0.000 600	152.095	0.285
EcTolor=-3.000, IorToloc=10.000 600	426.933	0.800

3GPP Specification TS 25.101, V6.10.0 Section 9.2.1

Specification requirements

IorToloc=0dB EcTolor=-6dB R=65kbps
 IorToloc=0dB EcTolor=-3dB R=N/A
 IorToloc=10dB EcTolor=-6dB R=309kbps
 IorToloc=10dB EcTolor=-3dB R=423kbps

Test results

Passed

Notes: Please go to page titled Equations to see variable definitions.

HSDPA HS-DSCH Demodulation Performance--Tables

Throughput results

Index	R		Pct	
	EcTolor=-6.000	EcTolor=-3.000	EcTolor=-6.000	EcTolor=-3.000
600	264.293	478.060	0.227	0.410

3GPP Specification TS 25.101, V6.10.0 Section 9.2.1

Specification requirements

lorToloc=10dB EcTolor=-6dB R=51kbps
lorToloc=10dB EcTolor=-3dB R=329kbps

Test results

Passed

Notes: Please go to page titled Equations to see variable definitions.

HSDPA HS-DSCH Demodulation Performance--Tables

Throughput results

Index	R		Pct	
	EcTolor=-6.000	EcTolor=-3.000	EcTolor=-6.000	EcTolor=-3.000
600	590.773	890.047	0.253	0.382

3GPP Specification TS 25.101, V6.10.0 Section 9.2.1

Specification requirements

lorToloc=10dB EcTolor=-6dB R=141kbps
 lorToloc=10dB EcTolor=-3dB R=642kbps

Test results

Passed

Notes: Please go to page titled Equations to see variable definitions.

Throughput Results (R) for User Equipment Demodulation Performance Measurement (Fading) Hset4 under PB3 channel with QPSK modulation

HSDPA HS-DSCH Demodulation Performance--Tables

Throughput results

Index	R	Pct
EcTolor=-6.000, IorToloc=0.000 1200	98.728	0.185
EcTolor=-6.000, IorToloc=10.000 1200	198.791	0.373
EcTolor=-3.000, IorToloc=0.000 1200	166.771	0.313
EcTolor=-3.000, IorToloc=10.000 1200	325.537	0.610

3GPP Specification TS 25.101, V6.10.0 Section 9.2.1

Specification requirements

IorToloc=0dB EcTolor=-6dB R=24kbps
 IorToloc=0dB EcTolor=-3dB R=142kbps
 IorToloc=10dB EcTolor=-6dB R=186kbps
 IorToloc=10dB EcTolor=-3dB R=299kbps

Test results

Passed

Notes: Please go to page titled Equations to see variable definitions.

Throughput Results (R) for User Equipment Demodulation Performance Measurement (Fading) Hset5 under VA120 channel with QPSK modulation

HSDPA HS-DSCH Demodulation Performance--Tables

Throughput results

Index	R	Pct
EcTolor=-6.000, IorToloc=0.000 600	141.422	0.177
EcTolor=-6.000, IorToloc=10.000 600	290.848	0.363
EcTolor=-3.000, IorToloc=0.000 600	242.818	0.303
EcTolor=-3.000, IorToloc=10.000 600	413.592	0.517

3GPP Specification TS 25.101, V6.10.0 Section 9.2.1

Specification requirements

IorToloc=0dB EcTolor=-6dB R=20kbps
 IorToloc=0dB EcTolor=-3dB R=210kbps
 IorToloc=10dB EcTolor=-6dB R=272kbps
 IorToloc=10dB EcTolor=-3dB R=413kbps

Test results

Passed

Notes: Please go to page titled Equations to see variable definitions.

Throughput Results (R) for User Equipment Demodulation Performance Measurement (Fading) Hset6 under PA3 channel with 16QAM modulation

HSDPA HS-DSCH Demodulation Performance--Tables

Throughput results

Index	R		Pct	
	EcTolor=-6.000	EcTolor=-3.000	EcTolor=-6.000	EcTolor=-3.000
600	898.629	1976.984	0.192	0.422

3GPP Specification TS 25.101, V6.10.0 Section 9.2.1

Specification requirements

lorToloc=10dB EcTolor=-6dB R=887kbps
lorToloc=10dB EcTolor=-3dB R=1664kbps

Test results

Passed

Notes: Please go to page titled Equations to see variable definitions.

Benchmark

Simulation time is about 4 hours for 2 sweep points of 600 2ms TTI over fading condition, on a P4/2.2GHz with 1GB memory PC running ADS 2005A on Microsoft Windows 2000.

HS-SCCH Detection Performance Measurements

UE_Rx_HSSCCH_Detection_TS1_PA3.dsn

Features

- User equipment receiver HS-SCCH signaling detection performance measurements
- Integrated RF models
- Multi-path fading propagation conditions

Description

These designs measure user equipment receiver HS-SCCH signaling detection performance according to section 9.4 in TS 34.121.

The schematic is shown below.

UE_Rx_HSSCCH_Detection_TS1_PA3.dsn Schematic

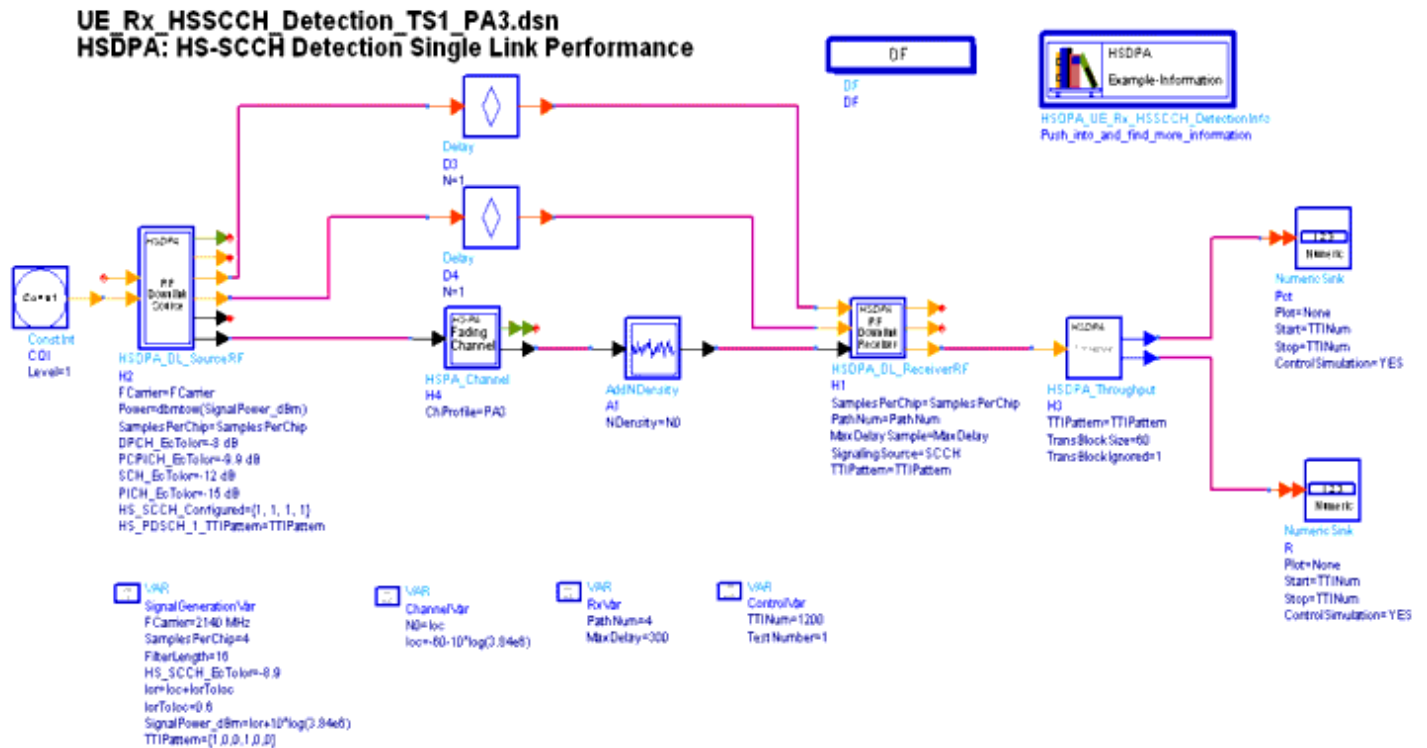

Simulation Results

Simulation results are shown below.

HSDPA HS-SCCH Detection Single Link Performance -- Tables

$\text{real}(\text{FCarrier})/(1 \text{ MHz})$	$\text{real}(\text{SignalPower_dBm})$
2140.000	-59.400

Testing results

Index	Measured_P_Em
1200	0.007

3GPP Specification TS 34.121 (2005-12) Section 9.4

Specification requirements

In the Specification TS 34.121, the measured $P(\text{Em})$ shall be less than or equal to the corresponding specified value of $P(\text{Em})$. For the
 TestNumber = 1, $P(\text{Em}) = 0.05$;
 TestNumber = 2 or 3, $P(\text{Em}) = 0.01$.

Notes: Please go to page titled Equations to see variable definitions.

Test results

Passed

Benchmark

Simulation time is about 6.6 hours, on a P4/2.26GHz, 1GB memory, PC running ADS 2005A on Microsoft Windows 2000.

Maximum Input Level Throughput Measurements

UE_Rx_MaxLevel.dsn Design

Features

- Measurement for user equipment receiver maximum input level

- Downlink reference measurement channels including 1HS-PDSCH, 1HS-SCCH, 1PCPCH, 1PSCH, 1SSCH, 1CPICH, 1 PICH and 16 OCNS interferers
- Existing RF channel loss
- Throughput of HS-DSCH

Description

This design measures user equipment receiver maximum input level per section 7.4 in TS25.101.

The schematic is shown below.

UE_Rx_MaxLevel.dsn Schematic

UE_Rx_MaxLevel.dsn

HSDPA: Maximum Input Level

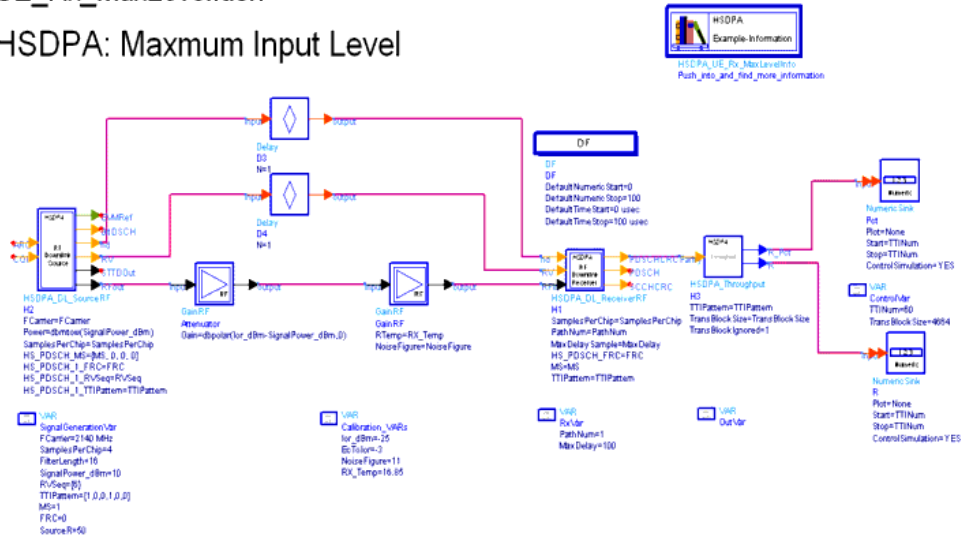

Gain factors of RF models in this design are set to satisfy a condition specified in TS 25.101:

- $\hat{I}_{or} = -25 \text{ dBm}/3.84 \text{ MHz}$
- $HS\text{-}PDSCH_{Ec}/I_{or} = -10 \text{ dBm}$
- Throughput performance of HS-DSCH must be no less than 700kbps

Simulation Results

Simulation results displayed in UE_Rx_Results.dds includes the Throughput of HS-DSCH which is shown below.

HSDPA Maximum input Level Measurement

Throughput Results

R
777.333

3GPP Specification TS 25.101, V6.10.0 Section 7.4.2

Specification requirements

The HS-DSCH throughput shall not less than 700 according to TS 25.101

Test results

Passed

Notes: Please go to page titled Equations to edit the Throughput threshold or to see variable definitions.

Benchmark

Simulation time is about 3 minutes with 60 TTI data points, on a P4/2.26 GHz, 1024 MB memory, PC running ADS 2005A on Microsoft Windows 2000.