



Agilent Technologies

ADS 2008
January 2008
TD-SCDMA Design Library

Advanced Design System 2008

© Agilent Technologies, Inc. 2000-2008

395 Page Mill Road, Palo Alto, CA 94304 U.S.A.

No part of this manual may be reproduced in any form or by any means (including electronic storage and retrieval or translation into a foreign language) without prior agreement and written consent from Agilent Technologies, Inc. as governed by United States and international copyright laws.

Acknowledgments

Mentor Graphics is a trademark of Mentor Graphics Corporation in the U.S. and other countries. Microsoft®, Windows®, MS Windows®, Windows NT®, and MS-DOS® are U.S. registered trademarks of Microsoft Corporation. Pentium® is a U.S. registered trademark of Intel Corporation. PostScript® and Acrobat® are trademarks of Adobe Systems Incorporated. UNIX® is a registered trademark of the Open Group. Java™ is a U.S. trademark of Sun Microsystems, Inc. SystemC® is a registered trademark of Open SystemC Initiative, Inc. in the United States and other countries and is used with permission. MATLAB® is a U.S. registered trademark of The Math Works, Inc.. HiSIM2 source code, and all copyrights, trade secrets or other intellectual property rights in and to the source code in its entirety, is owned by Hiroshima University and STARC.

Errata The ADS product may contain references to "HP" or "HPEESOF" such as in file names and directory names. The business entity formerly known as "HP EEsof" is now part of Agilent Technologies and is known as "Agilent EEsof". To avoid broken functionality and to maintain backward compatibility for our customers, we did not change all the names and labels that contain "HP" or "HPEESOF" references.

Warranty The material contained in this document is provided "as is", and is subject to being changed, without notice, in future editions. Further, to the maximum extent permitted by applicable law, Agilent disclaims all warranties, either express or implied, with regard to this manual and any information contained herein, including but not limited to the implied warranties of merchantability and fitness for a particular purpose. Agilent shall not be liable for errors or for incidental or consequential damages in connection with the furnishing, use, or performance of this document or of any information contained herein. Should Agilent and the user have a separate written agreement with warranty terms covering the material in this document that conflict with these terms, the warranty terms in the separate agreement shall control.

Technology Licenses The hardware and/or software described in this document are furnished under a license and may be used or copied only in accordance with the terms of such license. Portions of this product include the SystemC software licensed under Open Source terms, which are available for download at <http://systemc.org/>. This software is redistributed by Agilent. The Contributors of the SystemC software provide this software "as is" and offer no warranty of any kind, express or implied, including without limitation warranties or conditions or title and non-infringement, and implied warranties or conditions merchantability and fitness for a particular purpose. Contributors shall not be liable for any damages of any kind including without limitation direct, indirect, special, incidental and consequential damages, such as lost profits. Any provisions that differ from this disclaimer are offered by Agilent only.

Restricted Rights Legend If software is for use in the performance of a U.S. Government prime contract or subcontract, Software is delivered and licensed as "Commercial computer software" as defined in DFAR 252.227-7014 (June 1995), or as a "commercial item" as defined in FAR 2.101(a) or as "Restricted computer software" as defined in FAR 52.227-19 (June 1987) or any equivalent agency regulation or contract clause. Use, duplication or disclosure of Software is subject to Agilent Technologies' standard commercial license terms, and non-DOD Departments and Agencies of the U.S. Government will receive no greater than Restricted Rights as defined in FAR 52.227-19(c)(1-2) (June 1987). U.S. Government users will receive no greater than Limited Rights as defined in FAR 52.227-14 (June 1987) or DFAR 252.227-7015 (b)(2) (November 1995), as applicable in any technical data.

Contents

- About TD-SCDMA Design Library
- - Physical Layer
 - Physical Channel Signal Format
 - Burst Structure
 - Physical Channel Transmitter Structure
 - Component Libraries
 - Fully-Coded Source Components
 - Measurements Components
 - Modems Components
 - Multiplexing and Coding Components
 - Physical Channels Components
 - Receivers
 - Signal Sources
 - Glossary of Terms
- Fully Coded Sources
- - TDSCDMA_RefCh
 - Parameters
 - Pin Inputs
 - Pin Outputs
 - Notes/Equations
 - TDSCDMA_RefCh Schematic
 - 12.2 kbps UL Reference Measurement Channel
 - 12.2 kbps UL and DL Multi-Code Reference Measurement Channel
 - 64 kbps UL Reference Measurement Channel
 - 64 kbps DL Reference Measurement Channel
 - 144 kbps UL Reference Measurement Channel
 - 144 kbps DL Reference Measurement Channel
 - 384 kbps UL Reference Measurement Channel
 - 384 kbps DL Reference Measurement Channel
 - 12.2 kbps UL Reference Measurement Physical Channel Setting
 - 12.2 kbps UL and DL Multi-Code Reference Measurement Physical Channel Setting
 - 64 kbps UL Reference Measurement Physical Channel Setting
 - 64 kbps DL Reference Measurement Physical Channel Setting
 - 144 kbps UL Reference Measurement Channel Physical Channel Setting
 - 144 kbps DL Reference Measurement Physical Channel Setting
 - 384 kbps UL Reference Measurement Physical Channel Setting
 - 384 kbps DL Reference Measurement Physical Channel Setting
 - References
 - TDSCDMA_RefCh_RF
 - Parameters
 - Pin Outputs
 - Notes/Equations
 - TDSCDMA_RefCh_RF Schematic
- Measurements for TD-SCDMA Design Library
- - TDSCDMA_BER
 - Parameters

- Pin Inputs
- Pin Outputs
- Notes/Equations
- TDSCDMA_Constellation
- - Parameters
- Pin Inputs
- Notes/Equations
- - TDSCDMA_Constellation Schematic
- References
- TDSCDMA_EVM
- - Parameters
- Pin Inputs
- Notes/Equations
- - Associated Codes
- TDSCDMA_FrameSync
- - Parameters
- Pin Inputs
- Pin Outputs
- Notes/Equations
- - TDSCDMA_FrameSync Schematic
- References
- TDSCDMA_RF_CCDF
- - Parameters
- Pin Inputs
- Notes/Equations
- - TDSCDMA_RF_CCDF Schematic
- References
- TDSCDMA_RF_PwrMeasure
- - Parameters
- Pin Inputs
- Notes/Equations
- - TDSCDMA_RF_PwrMeasure Schematic
- References
- Modems for TD-SCDMA Design Library
- ◦ TDSCDMA_BurstDeMux
- - Parameters
- Pin Inputs
- Pin Outputs
- Notes/Equations
- - TDSCDMA_BurstDeMux Schematic
- - Burst Structure of Traffic Burst Format
- References
- TDSCDMA_BurstMux
- - Pin Inputs
- Pin Outputs
- Notes/Equations
- - Burst Structure of Traffic Burst Format
- References
- TDSCDMA_Demodulator
- - Parameters

- Pin Inputs
- Pin Outputs
- Notes/Equations
- References
- TDSCDMA_DPCH_DataDeMux
 - - Parameters
 - Pin Inputs
 - Pin Outputs
 - Notes/Equations
 - TDSCDMA_DPCH_DataDeMux Schematic
 - TDSCDMA Slot Structure
 - Downlink Time Slot Formats
 - Uplink Time Slot Formats
 - 8PSK Modulation Time Slot Formats
 - References
- TDSCDMA_DPCH_DataMux
 - - Parameters
 - Pin Inputs
 - Pin Outputs
 - Notes/Equations
 - Burst Structure of Traffic Burst Format
 - Downlink Time Slot Formats
 - Uplink Time Slot Formats
 - 8PSK Modulation Time Slot Formats
 - References
- TDSCDMA_DPCH_Mux
 - - Parameters
 - Pin Inputs
 - Pin Outputs
 - Notes/Equations
 - References
- TDSCDMA_Midamble
 - - Parameters
 - Pin Outputs
 - Notes/Equations
 - Mapping of 4 Binary Elements m_i on a Single Hexadecimal Digit
 - References
- TDSCDMA_Modulator
 - - Parameters
 - Pin Inputs
 - Pin Outputs
 - Notes/Equations
 - Symbol Mapping
 - Symbol Mapping
 - References
- TDSCDMA_OnePhyCh
 - - Parameters
 - Pin Inputs
 - Pin Outputs
 - Notes/Equations

- - Structure of Subframe for 1.28Mcps TDD Option
 - References
- TDSCDMA_OnePhyChDeMux
- - Parameters
- Pin Inputs
- Pin Outputs
- Notes/Equations
- - TDSCDMA_OnePhyChDeMux Schematic
- - Structure of Subframe for 1.28Mcps TDD Option
- References
- TDSCDMA_OVSF
- - Parameters
- Pin Outputs
- Notes/Equations
- - Table 4-10. Multiplier of Channelization Code
- References
- TDSCDMA_PSCH_DataMux
- - Parameters
- Pin Inputs
- Pin Outputs
- Notes/Equations
- References
- TDSCDMA_Scramble
- - Parameters
- Pin Outputs
- Notes/Equations
- References
- TDSCDMA_Sync
- - Parameters
- Pin Outputs
- Notes/Equations
- - Phase Modulation Sequences for SYNC-DL
- References
- Multiplexing and Coding Components
- ◦ TDSCDMA_1stDeIntlvr
- - Parameters
- Pin Inputs
- Pin Outputs
- Notes/Equations
- References
- TDSCDMA_1stIntlvr
- - Parameters
- Pin Inputs
- Pin Outputs
- Notes/Equations
- References
- TDSCDMA_2ndDeIntlvr
- - Parameters
- Pin Inputs
- Pin Outputs

- Notes/Equations
- References
- TDSCDMA_2ndIntlvr
 - - Parameters
 - Pin Inputs
 - Pin Outputs
 - Notes/Equations
 - References
- TDSCDMA_BitScrambling
 - - Parameters
 - Pin Inputs
 - Pin Outputs
 - Notes/Equations
 - References
- TDSCDMA_ChCoding
 - - Parameters
 - Pin Inputs
 - Pin Outputs
 - Notes/Equations
 - - Channel Coding Schemes and Rates for 1.28 Mcps TDD
 - References
- TDSCDMA_ChDecoding
 - - Parameters
 - Pin Inputs
 - Pin Outputs
 - Notes/Equations
 - - Channel Coding Schemes and Rates for 1.28Mcps TDD
 - References
- TDSCDMA_CodeBlkSeg
 - - Parameters
 - Pin Inputs
 - Pin Outputs
 - Notes/Equations
 - References
- TDSCDMA_CRC_Decoder
 - - Parameters
 - Pin Inputs
 - Pin Outputs
 - Notes/Equations
 - References
- TDSCDMA_CRC_Encoder
 - - Parameters
 - Pin Inputs
 - Pin Outputs
 - Notes/Equations
 - References
- TDSCDMA_DeCodeBlkSeg
 - - Parameters
 - Pin Inputs
 - Pin Outputs

- Notes/Equations
- References
- TDSCDMA_DePhyChMap
 - - Parameters
 - Pin Inputs
 - Pin Outputs
 - Notes/Equations
 - References
- TDSCDMA_DePhyChSeg
 - - Parameters
 - Pin Inputs
 - Pin Outputs
 - Notes/Equations
 - - Array Values
 - References
- TDSCDMA_DeRadioEqual
 - - Parameters
 - Pin Inputs
 - Pin Outputs
 - Notes/Equations
 - References
- TDSCDMA_DeRadioSeg
 - - Parameters
 - Pin Inputs
 - Pin Outputs
 - Notes/Equations
 - References
- TDSCDMA_DeRateMatch
 - - Parameters
 - Pin Inputs
 - Pin Outputs
 - Notes/Equations
 - - Array Values
 - References
- TDSCDMA_DeSubFrameSeg
 - - Parameters
 - Pin Inputs
 - Pin Outputs
 - Notes/Equations
 - References
- TDSCDMA_PhyChMap
 - - Parameters
 - Pin Inputs
 - Pin Outputs
 - Notes/Equations
 - References
- TDSCDMA_PhyChSeg
 - - Parameters
 - Pin Inputs
 - Pin Outputs

Advanced Design System 2008

- Notes/Equations
- - Array Values
- References
- TDSCDMA_RadioEqual
- - Parameters
- Pin Inputs
- Pin Outputs
- Notes/Equations
- References
- TDSCDMA_RadioSeg
- - Parameters
- Pin Inputs
- Pin Outputs
- Notes/Equations
- References
- TDSCDMA_RateMatch
- - Parameters
- Pin Inputs
- Pin Outputs
- Notes/Equations
- - Array Values
- References
- TDSCDMA_RefChDecoder
- - Parameters
- Pin Inputs
- Pin Outputs
- Notes/Equations
- - TDSCDMA_RefChDecoder Schematic
- 12.2 kbps UL Reference Measurement Channel
- 12.2 kbps UL and DL Multi-Code Reference Measurement Channel
- 64 kbps UL Reference Measurement Channel
- 64 kbps DL Reference Measurement Channel
- 144 kbps UL Reference Measurement Channel
- 144 kbps DL Reference Measurement Channel
- 384 kbps UL Reference Measurement Channel
- 384 kbps DL Reference Measurement Channel
- Physical Channel Setting of 12.2 kbps UL Reference Measurement Channel
- Physical Channel Setting of 12.2 kbps UL and DL Multi-Code Reference Measurement Channel
- Physical Channel Setting 64 kbps UL Reference Measurement Channel
- Physical Channel Setting of 64 kbps DL Reference Measurement Channel
- Physical Channel Setting of 144 kbps UL Reference Measurement Channel
- Physical Channel Setting of 144 kbps DL Reference Measurement Channel
- Physical Channel Setting of 384 kbps UL Reference Measurement Channel
- Physical Channel Setting of 384 kbps DL Reference Measurement Channel
- References
- TDSCDMA_RM_Cal
- - Parameters
- Pin Outputs
- Notes/Equations
- References

- TDSCDMA_SubFrameSeg
 - - Parameters
 - Pin Inputs
 - Pin Outputs
 - Notes/Equations
 - References
- TDSCDMA_TFCI_Encoder
 - - Parameters
 - Pin Inputs
 - Pin Outputs
 - Notes/Equations
 - - TFCI Coding Options
 - References
- TDSCDMA_TrChDeMux
 - - Parameters
 - Pin Inputs
 - Pin Outputs
 - Notes/Equations
 - - Array Values
 - References
- TDSCDMA_TrChMux
 - - Parameters
 - Pin Inputs
 - Pin Outputs
 - Notes/Equations
 - - Array Values
 - References
- Physical Channel Components
 - TDSCDMA_DPCH
 - - Parameters
 - Pin Inputs
 - Pin Outputs
 - Notes/Equations
 - - TDSCDMA_DPCH Schematic
 - Sub-Frame Structure for 1.28Mcps TDD Option
 - Burst Structure of Traffic Burst Format
 - Time Slot Formats for Downlink with QPSK Modulation
 - Time Slot Formats for Uplink with QPSK Modulation
 - Time Slot Formats for 8PSK modulation
 - References
 - TDSCDMA_DwPCH
 - - Parameters
 - Pin Outputs
 - Notes/Equations
 - - TDSCDMA_DwPCH Schematic
 - References
 - TDSCDMA_FPACH
 - - Parameters
 - Pin Inputs
 - Pin Outputs

- Notes/Equations
 - - TDSCDMA_FPACH Schematic
- References
- TDSCDMA_PCCPCH
- - Parameters
- Pin Inputs
- Pin Outputs
- Notes/Equations
 - - TDSCDMA_PCCPCH Schematic
- References
- TDSCDMA_PICH
- - Notes/Equations
 - - TDSCDMA_PICH Schematic (1 of 2)
 - - TDSCDMA_PICH Schematic (2 of 2)
 - - Transmission of Paging Indicator Carrying Bits in PICH Bursts
- References
- TDSCDMA_PRACH
- - Parameters
- Pin Inputs
- Pin Outputs
- Notes/Equations
 - - TDSCDMA_PRACH Schematic
- References
- TDSCDMA_PSCH
- - Parameters
- Pin Inputs
- Pin Outputs
- Notes/Equations
 - - TDSCDMA_PSCH Schematic
- References
- TDSCDMA_SCCPCH
- - Parameters
- Pin Inputs
- Pin Outputs
- Notes/Equations
 - - TDSCDMA_SCCPCH Schematic
- References
- TDSCDMA_UpPCH
- - Parameters
- Pin Outputs
- Notes/Equations
 - - TDSCDMA_UpPCH Schematic
- References
- Receivers for TD-SCDMA Design Library
- ◦ TDSCDMA_12_2_DL_JD_Receiver
 - - Parameters
 - Pin Inputs
 - Pin Outputs
 - Notes/Equations
 - - TDSCDMA_12_2_DL_JD_Receiver Schematic

- References
- TDSCDMA_12_2_DL_RakeReceiver
 - - Parameters
 - Pin Inputs
 - Pin Outputs
 - Notes/Equations
 - - TDSCDMA_12_2_DL_RakeReceiver Schematic
 - References
- TDSCDMA_12_2_UL_JD_Receiver
 - - Parameters
 - Pin Inputs
 - Pin Outputs
 - Notes/Equations
 - - TDSCDMA_12_2_UL_JD_Receiver Schematic
 - References
- TDSCDMA_12_2_UL_RakeReceiver
 - - Parameters
 - Pin Inputs
 - Pin Outputs
 - Notes/Equations
 - - TDSCDMA_12_2_UL_RakeReceiver Schematic
 - References
- TDSCDMA_A_Generator
 - - Parameters
 - Pin Inputs
 - Pin Outputs
 - Notes/Equations
 - - TDSCDMA_A_Generator Schematic
 - - Structure of Matrix A
 - References
- TDSCDMA_b_k_Generator
 - - Parameters
 - Pin Inputs
 - Pin Outputs
 - Notes/Equations
 - - TDSCDMA_b_k_Generator Schematic
 - References
- TDSCDMA_ChannelEstimation
 - - Parameters
 - Pin Inputs
 - Pin Outputs
 - Notes/Equations
 - - TDSCDMA_ChannelEstimation Schematic
 - References
- TDSCDMA_JointDetection
 - - Parameters
 - Pin Inputs
 - Pin Outputs
 - Notes/Equations
 - - TDSCDMA_JointDetection Schematic

- References
- TDSCDMA_Rake
 - Parameters
 - Pin Inputs
 - Pin Outputs
 - Notes/Equations
 - TDSCDMA_Rake Schematic
 - References
- Signal Sources for TD-SCDMA Design Library
 - TDSCDMA_DL_RF
 - Parameters
 - Pin Outputs
 - Notes/Equations
 - TDSCDMA_DL_RF Schematic
 - SubFrame Structure of 12.2 kbps DL Channel
 - Phase Modulation Sequences for Downlink Synchronization Code
 - References
 - TDSCDMA_DL_Src
 - Parameters
 - Pin Inputs
 - Pin Outputs
 - Notes/Equations
 - TDSCDMA_DL_Src Schematic
 - Frame Structure of 12.2 kbps Downlink Channel
 - References
 - TDSCDMA_DnLinkRF
 - Parameters
 - Pin Outputs
 - Notes/Equations
 - Signal Source Block Diagram
 - TD-SCDMA Downlink Source
 - Subframe Structure of 12.2 kbps DL Channel
 - Phase Modulation Sequences
 - References
 - TDSCDMA_UpLinkRF
 - Parameters
 - Pin Outputs
 - Notes/Equations
 - Signal Source Block Diagram
 - Source Power
 - Subframe Structure of 12.2 kbps Uplink Channel
 - References
 - TDSCDMA_OCNS
 - Parameters
 - Pin Outputs
 - Notes/Equations
 - References
 - TDSCDMA_SlotSrc
 - Parameters
 - Pin Outputs

- Notes/Equations
 - - Example of a SubFrame Structure
- References
- TDSCDMA_UL_RF
 - - Parameters
 - Pin Outputs
 - Notes/Equations
 - - TDSCDMA_UL_RF Schematic
 - - SubFrame Structure of 12.2 kbps Uplink Channel
 - References
- TDSCDMA_UL_Src
 - - Parameters
 - Pin Inputs
 - Pin Outputs
 - Notes/Equations
 - - TDSCDMA_UL_Src Schematic
 - - Frame Structure of 12.2 kbps UL Channel
 - References

About TD-SCDMA Design Library

TD-SCDMA is a Chinese contribution to the international family of Mobile Radio Systems for 3G services of UMTS and IMT 2000. It is now one option of UTRA-TDD, called 1.28 Mcps TDD or low chip rate (LCR) TDD and it is an advanced CDMA/TDMA/TDD system with an adaptive synchronous operation.

TD-SCDMA system simulation models based on the 3GPP TDD LCR standard demonstrate signal generation and receiving capabilities; basic measurements are considered. TD-SCDMA aligns with the same version of the specification used by the Agilent ESG-C, PSA II and VSA.

Physical Layer

The frame structure, illustrated in the following figure, recognizes new smart antenna and uplink synchronization technologies.

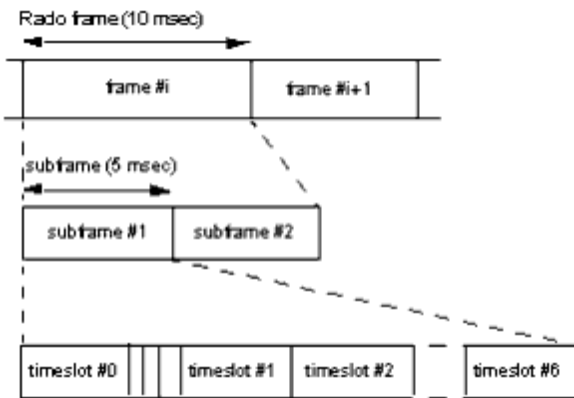

Physical Channel Signal Format

Uplink and downlink time slots in each frame are separated by a switching point. Each sub-frame has two switching points: TS0 is always allocated as downlink; TS1 is always allocated as uplink. The three special time slots are:

- DwPTS: downlink pilot time slot, 96 chip duration.
- UpPTS: uplink pilot time slot, 160 chip duration.
- GP: main guard period for TDD operation, 96 chip duration.

The system can operate on symmetric and asymmetric modes by properly configuring the number of downlink and uplink time slots.

The burst structure is illustrated in the following figure.

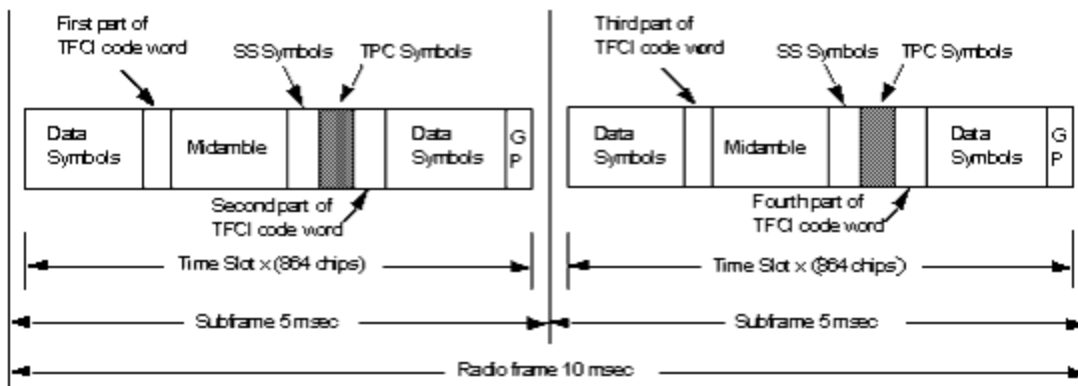

Burst Structure

The transmitter structure of a physical channel is illustrated in the following figure.

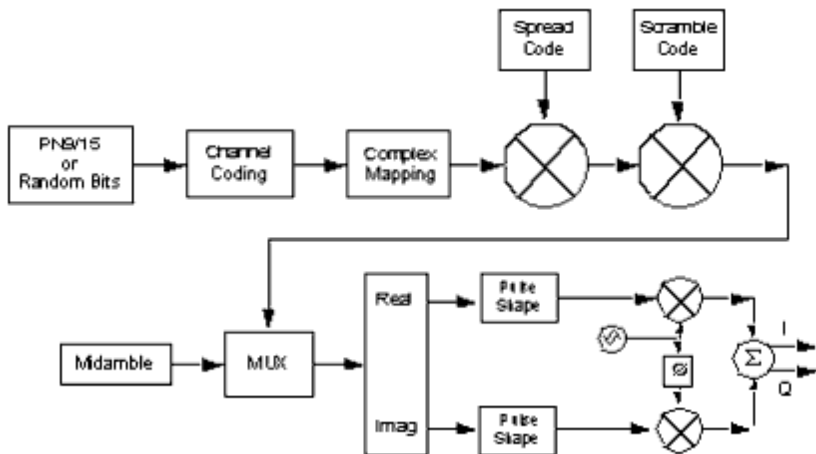

Physical Channel Transmitter Structure

Physical channels have a 3-layer structure.

- Time slot: 675 μ sec slot consisting of a number of Symbols. Time slots are used in a TDMA component to separate different user signals in time and code domain.
- Radio frame: 5 μ sec frame consisting of 7 time slots.
- System frame numbering.

Component Libraries

The TD-SCDMA Design Library consists of behavioral models and subnetworks organized in libraries that are described in the following sections.

Fully-Coded Source Components

Fully-coded source library components provide fully-coded downlink and uplink sources according to the reference measurement channel specifications.

Measurements Components

Measurements library components measure BER/BLER, EVM, constellation, complementary cumulative distribution function and RF power, and provide multipath fading channels.

Advanced Design System 2008

- TDSCDMA_BER calculates the BER and BLER by comparing the two input signals.
- TDSCDMA_Constellation measures the constellation of the received signal.
- TDSCDMA_EVM measures the EVM of the input signal.
- TDSCDMA_RF_CCDF measures the CCDF of the RF signal.
- TDSCDMA_RF_PwrMeasure measures RF signal average power and power vs. time.
- TDSCDMA_FwdChannel and TDSCDMA_RevChannel are the multipath fading channels for forward and reverse links, respectively. The profile of the channel is according to 3GPP TDD specifications.

Modems Components

Modems library components provide modulation, OVSF and spreading code generation, synchronization and midamble code generation, burst and frame generation.

- TDSCDMA_BurstMux generates a burst in a physical channel.
- TDSCDMA_DPCH_DataMux multiplexes TFCI, SS, and TPC data in a dedicated physical channel.
- TDSCDMA_Midamble generates midamble codes.
- TDSCDMA_Modulator performs QPSK and 8PSK modulation.
- TDSCDMA_OnePhyCh generates a sub-frame in a physical channel.
- TDSCDMA_OVSF generates OVSF codes.
- TDSCDMA_PSCH_DataMux multiplexes time division data in a shared physical channel.
- TDSCDMA_Scramble generates scramble codes.
- TDSCDMA_Sync generates synchronization codes.

Multiplexing and Coding Components

The Multiplexing and Coding library components include interleaving, rate matching, channel coding, and physical channel mapping.

- TDSCDMA_TFCI_Encoder encodes TFCI bits into TFCI code words.
- TDSCDMA_1stIntlv, TDSCDMA_1stDeIntlv, TDSCDMA_2ndIntlv and TDSCDMA_2ndDeIntlv are the first and the second interleavers and de-interleavers, respectively.
- TDSCDMA_CRC_Encoder and TDSCDMA_CRC_Decoder are the CRC encoder and the decoder, respectively.
- TDSCDMA_ChCoding and TDSCDMA_ChDecoding are the channel encoder and the decoder, respectively; coding schemes can be convolutional and Turbo.
- TDSCDMA_RateMatch and TDSCDMA_DeRateMatch provide rate match and de-match, respectively, for physical channels.
- TDSCDMA_RefChDecoder is a sub-network which implements a complete decoding process after demodulation for reference measurement channels.

Physical Channels Components

Advanced Design System 2008

Physical Channels library Components generate physical channel signals.

- TDSCDMA_DPCH generates dedicated physical channel signals.
- TDSCDMA_DwPCH generates downlink synchronization channel signals.
- TDSCDMA_FPACH generates fast physical access channel signals.
- TDSCDMA_PCCPCH generates primary common control physical channel signals.
- TDSCDMA_PICH generates page indicator channel signals.
- TDSCDMA_PRACH generates physical random access channel signals.
- TDSCDMA_PSCH generates physical downlink/uplink shared channel signals.
- TDSCDMA_SCCPCH generates secondary common control physical channel signals.
- TDSCDMA_UpPCH generates uplink synchronization channel signals.

Receivers

Receiver library components configure Rake and joint detection (JD) receivers.

- TDSCDMA_ChannelEstimation implements channel estimation for both Rake and joint detection receivers.
- TDSCDMA_12_2_DL_JD_Receiver is a joint detection receiver for 12.2 kbps downlink reference channel with 8 DPCH0.
- TDSCDMA_12_2_UL_JD_Receiver is a joint detection receiver for 12.2 kbps uplink reference channel with 4 DPCH0.
- TDSCDMA_12_2_DL_RakeReceiver and TDSCDMA_12_2_UL_RakeReceiver are Rake receivers for 12.2 kbps downlink and uplink reference channels, respectively.

Signal Sources

Signal Sources library components generate uplink and downlink signal sources.

- TDSCDMA_DL_RF generates downlink RF signals of DPCH with a 12.2 kbps data rate.
- TDSCDMA_DL_Src generates downlink baseband signals of DPCH with a 12.2 kbps data rate.
- TDSCDMA_UL_RF generates uplink RF signals of DPCH with a 12.2 kbps data rate.
- TDSCDMA_UL_Src generates uplink baseband signals of DPCH with a 12.2 kbps data rate.

Glossary of Terms

TD-SCDMA	time division - synchronization code division multi-access
8PSK	8-ary phase shift keying

ACLR	adjacent channel leakage ratio
BER	bit error ratio
BLER	block error ratio
bps	bits per second
CCDF	complementary cumulative distribution function
CDMA	code division multiple access
DPCH	dedicated physical channel
DwPCH	downlink pilot channel
DwPTS	downlink pilot time slot
FPACH	fast physical access channel
GP	guard period
JD	joint detection
LCR	low chip rate
OVSF	orthogonal variable spreading factor
PCCPCH	primary common control physical channel
PDSCH	physical downlink shared channel
PICH	page indicator channel
PRACH	physical random access channel
PUSCH	physical uplink shared channel
QPSK	quadrature phase shift keying
SCCPCH	secondary common control physical channel
TDD	time division duplex
TFCI	transmit format combination indicator
UpPCH	uplink pilot channel
UpPTS	uplink pilot time slot

Fully Coded Sources

TDSCDMA_RefCh



Description Reference measurement channel
 Library TDSCDMA, Fully Coded Source
 Class SDFTDSCDMA_RefCh

Parameters

Name	Description	Default	Type	Range
Link	link selection: Downlink, Uplink	Downlink	enum	
RefCh	reference channel selection indicator: CH_12.2k_MultiCode, CH_12.2k_SingleCode, CH_64k, CH_144k, CH_384k	CH_12.2k_MultiCode	enum	
PhyChNum_SA	physical channel allocation configuration	0 0 2 0 0 0 0	int array	[0, 16] for Downlink, [0,2] for Uplink
MaxPhyChNum	sum of allocated physical channel in all slots	2	int	[1, 112]
ModType_SA	type of modulation of all slots, 0 for QPSK, 1 for 8PSK	0 0 0 0 0 0 0	int array	{0, 1}
TFCI_SA	allocated TFCI transmitted active slots configuration	0 0 1 0 0 0 0	int array	{0, 1}
TFCI_Length_SA	length of TFCI of all slots	0 0 16 0 0 0 0	int array	{0, 4,8,16,32} for QPSK, {0,6,12,24,48} for 8PSK
SS_TPC_SA	type of SS and TPC of all slots	2 2 1 2 2 2 2	int array	{1, 2,3}
MinSF_PA	minimum spreading factor array corresponding to allocated physical	16 16	int array	{1, 16} for Downlink, {1,2,4,8,16} for Uplink

Advanced Design System 2008

	channels			
SpreadCode_PA	index of OVFSF code corresponding to allocated physical channels	1 2	int array	
BasicMidambleID	index of basic midamble	1	int	
K_SA	maximum number of midamble shifts in a cell for all slots	16 16 16 16 16 16 16	int array	
MidambleID_SA	index of midamble for all slots	5 5 5 5 5 5	int array	
Gain_PA	gain setting array corresponding to allocated physical channels	1.0 1.0	real array	

Pin Inputs

Pin	Name	Description	Signal Type
1	DCH	DCH data out	int

Pin Outputs

Pin	Name	Description	Signal Type
2	OutI	out	real
3	OutQ	out	real

Notes/Equations

1. This subnetwork implements a reference measurement channel.
The schematic for this subnetwork is shown in the following figure.

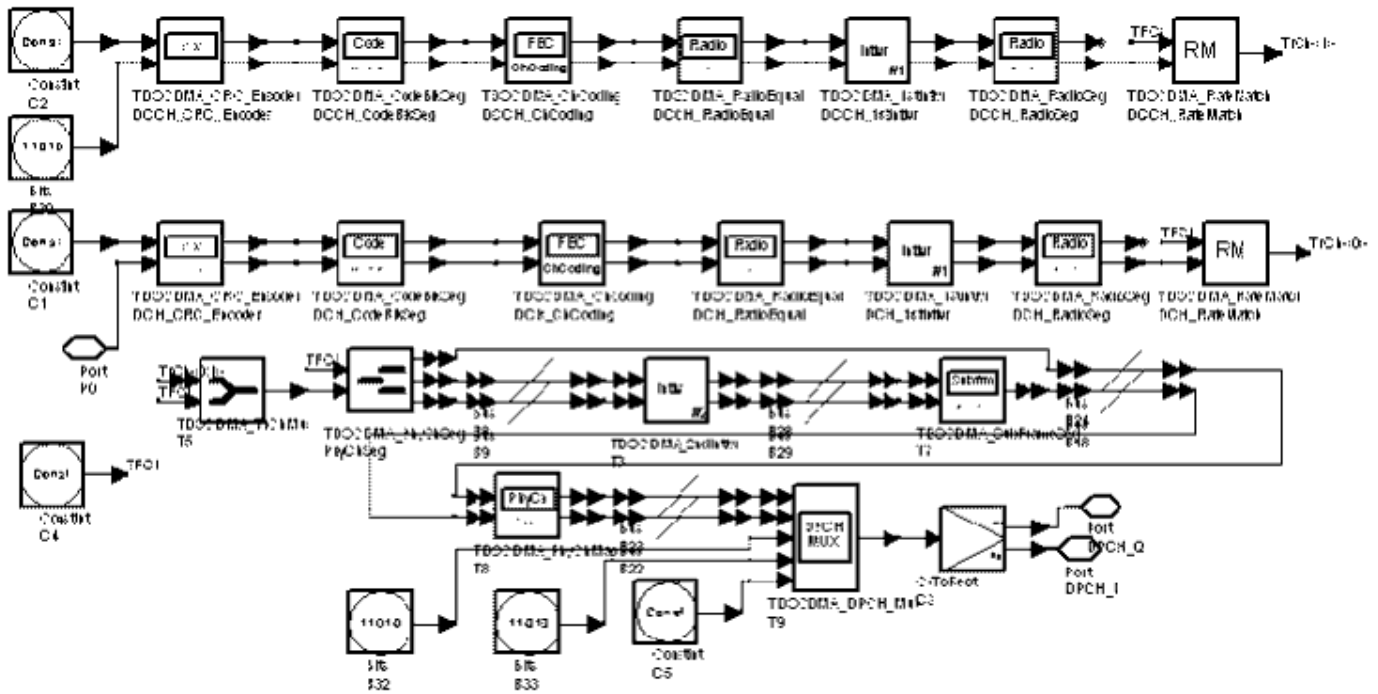

TDSCDMA_RefCh Schematic

2. MinSF_PA indicates the minimum spread factor that can be used for corresponding physical channel. The size of MinSF_PA must be equal to the sum of PhyChNum_SA elements.
3. SS_TPC_SA indicates the number of SS and TPC symbols transmitted in each slot: 1 denotes one SS and one TPC symbols are transmitted; 2 denotes no SS and no TPC symbols are transmitted; 3 denotes 16/SF SS and 16/SF TPC symbols are transmitted, where SF is the spreading factor of the physical channel used to transmitted SS and TPC symbols. Only the first allocated physical channel in each slot is used to transmit SS and TPC symbols.
4. The structure and settings for the various data rates are given in the following tables.

12.2 kbps UL Reference Measurement Channel

Parameter	Value
Information data rate	12.2 kbps
RUs allocated	1TS (1 × SF8) = 2RU/5ms
Midamble	144
Interleaving	20 ms
Power control	4 Bit/user/10ms
TFCI	16 Bit/user/10ms
4 Bit reserved for future use (place of SS)	4 Bit/user/10ms
Inband signalling DCCH	2.4 kbps
Puncturing level at code rate 1/3: DCH / DCCH	33% / 33%

Advanced Design System 2008

12.2 kbps UL and DL Multi-Code Reference Measurement Channel

Parameter	Value
Information data rate	12.2 kbps
RUs allocated	1TS (2 × SF16) = 2RU/5ms
Midamble	144
Interleaving	20 ms
Power control (TPC)	4 Bit/user/10ms
TFCI	16 Bit/user/10ms
Synchronization shift (SS)	4 Bit/user/10ms
Inband signalling DCCH	2.4 kbps
Puncturing level at code rate 1/3: DCH / DCCH	33% / 33%

64 kbps UL Reference Measurement Channel

Parameter	Value
Information data rate	64 kbps
RUs allocated	1TS (1 × SF2) = 8RU/5ms
Midamble	144
Interleaving	20 ms
Power control (TPC)	4 Bit/user/10ms
TFCI	16 Bit/user/10ms
Synchronization shift (SS)	4 Bit/user/10ms
Inband signalling DCCH	2.4 kbps
Puncturing level at code rate: 1/3 DCH / 0 DCCH	32% / 0

64 kbps DL Reference Measurement Channel

Parameter	Value
Information data rate	64 kbps
RUs allocated	1TS (8 × SF16) = 8RU/5ms
Midamble	144
Interleaving	20 ms
Power control (TPC)	4 Bit/user/10ms
TFCI	16 Bit/user/10ms

Advanced Design System 2008

Synchronization shift (SS)	4 Bit/user/10ms
Inband signalling DCCH	2.4 kbps
Puncturing level at Code rate: 1/3 DCH / \int DCCH	32% / 0

144 kbps UL Reference Measurement Channel

Parameter	Value
Information data rate	144 kbps
RUs allocated	2TS (1 \times SF2) = 16RU/5ms
Midamble	144
Interleaving	20 ms
Power control (TPC)	8 Bit/user/10ms
TFCI	32 Bit/user/10ms
Synchronization shift (SS)	8 Bit/user/10ms
Inband signalling DCCH	2.4 kbps
Puncturing level at code rate: 1/3 DCH / \int DCCH	38% / 7%

144 kbps DL Reference Measurement Channel

Parameter	Value
Information data rate	144 kbps
RUs allocated	2TS (8 \times SF16) = 16RU/5ms
Midamble	144
Interleaving	20 ms
Power control (TPC)	8 Bit/user/10ms
TFCI	32 Bit/user/10ms
Synchronization shift (SS)	8 Bit/user/10ms
Inband signalling DCCH	2.4 kbps
Puncturing level at code rate: 1/3 DCH / \int DCCH	38% / 7%

384 kbps UL Reference Measurement Channel

Parameter	Value
Information data rate	384 kbps
RU's allocated	4TS (1 \times SF2 + 1 \times SF8) = 40RU/5ms

Advanced Design System 2008

Midamble	144
Interleaving	20 ms
Power control (TPC)	16 Bit/user/10ms
TFCI	64 Bit/user/10ms
Synchronization Shift (SS)	16 Bit/user/10ms
Inband signalling DCCH	max 2.0 kbps
Puncturing level at Code rate: 1/3 DCH / \int DCCH	41% / 12%

384 kbps DL Reference Measurement Channel

Parameter	Value
Information data rate	384 kbps
RU's allocated	4TS (10 × SF16) = 40RU/5ms
Midamble	144
Interleaving	20 ms
Power control (TPC)	16 Bit/user/10ms
TFCI	64 Bit/user/10ms
Synchronization Shift (SS)	16 Bit/user/10ms
Inband signalling DCCH	max. 2 kbps
Puncturing level at Code rate: 1/3 DCH / \int DCCH	41% / 12%

5. The configuration for transport channels is fixed when the Link and RefCh parameter are set. The configuration for physical channels can be set flexibly according to the previous tables. An example for each configuration is shown in the following tables.

12.2 kbps UL Reference Measurement Physical Channel Setting

Parameter	Value
Link	Uplink
RefCh	12.2K_SingleCode
PhyChNum_SA	0 0 1 0 0 0 0
MaxPhyChNum	1
ModType_SA	0[7]
TFCI_SA	0 0 1 0 0 0 0
TFCI_Length_SA	0 0 16 0 0 0 0
SS_TPC_SA	2 2 1 2 2 2 2

Advanced Design System 2008

MinSF_PA	8
SpreadCode_PA	1
Gain_PA	1.0

12.2 kbps UL and DL Multi-Code Reference Measurement Physical Channel Setting

Parameter	Value
Link	Uplink for UL and Downlink for DL
RefCh	12.2K_MultiCode
PhyChNum_SA	0 0 2 0 0 0 0
MaxPhyChNum	2
ModType_SA	0[7]
TFCI_SA	0 0 1 0 0 0 0
TFCI_Length_SA	0 0 16 0 0 0 0
SS_TPC_SA	2 2 1 2 2 2 2
MinSF_PA	16[2]
SpreadCode_PA	1 3
Gain_PA	1.0[2]

64 kbps UL Reference Measurement Physical Channel Setting

Parameter	Value
Link	Uplink
RefCh	64K
PhyChNum_SA	0 0 1 0 0 0 0
MaxPhyChNum	1
ModType_SA	0[7]
TFCI_SA	0 0 1 0 0 0 0
TFCI_Length_SA	0 0 16 0 0 0 0
SS_TPC_SA	2 2 1 2 2 2 2
MinSF_PA	2
SpreadCode_PA	1
Gain_PA	1.0

64 kbps DL Reference Measurement Physical Channel Setting

Advanced Design System 2008

Parameter	Value
Link	Downlink
RefCh	64K
PhyChNum_SA	0 0 8 0 0 0 0
MaxPhyChNum	8
ModType_SA	0[7]
TFCI_SA	0 0 1 0 0 0 0
TFCI_Length_SA	0 0 16 0 0 0 0
SS_TPC_SA	2 2 1 2 2 2 2
MinSF_PA	16[8]
SpreadCode_PA	1 3 5 7 9 11 13 15
Gain_PA	1.0[8]

144 kbps UL Reference Measurement Channel Physical Channel Setting

Parameter	Value
Link	Uplink
RefCh	144K
PhyChNum_SA	0 0 1 1 0 0 0
MaxPhyChNum	2
ModType_SA	0[7]
TFCI_SA	0 0 1 1 0 0 0
TFCI_Length_SA	0 0 16 16 0 0 0
SS_TPC_SA	2 2 1 1 2 2 2
MinSF_PA	2[2]
SpreadCode_PA	1 2
Gain_PA	1.0[2]

144 kbps DL Reference Measurement Physical Channel Setting

Parameter	Value
Link	Downlink
RefCh	144K
PhyChNum_SA	0 0 8 8 0 0

Advanced Design System 2008

MaxPhyChNum	16
ModType_SA	0[7]
TFCI_SA	0 0 1 1 0 0 0
TFCI_Length_SA	0 0 16 16 0 0 0
SS_TPC_SA	2 2 1 1 2 2 2
MinSF_PA	16[16]
SpreadCode_PA	1 3 5 7 9 11 13 15 2 4 6 8 10 12 14 16
Gain_PA	1.0[16]

384 kbps UL Reference Measurement Physical Channel Setting

Parameter	Value
Link	Uplink
RefCh	384K
PhyChNum_SA	0 0 2 2 2 2 0
MaxPhyChNum	8
ModType_SA	0[7]
TFCI_SA	0 0 1 1 1 1 0
TFCI_Length_SA	0 0 16 16 16 16 0
SS_TPC_SA	2 2 1 1 1 1 2
MinSF_PA	8 2 8 2 8 2 8 2
SpreadCode_PA	1 2 1 2 1 2 1 2
Gain_PA	1.0[8]

384 kbps DL Reference Measurement Physical Channel Setting

Parameter	Value
Link	Downlink
RefCh	384K
PhyChNum_SA	0 0 10 10 10 10 0
MaxPhyChNum	1
ModType_SA	0[7]
TFCI_SA	0 0 1 1 1 1 0
TFCI_Length_SA	0 0 16 16 16 16 0

SS_TPC_SA	2 2 1 1 1 1 2
MinSF_PA	16[40]
SpreadCode_PA	1 3 5 7 9 11 13 15 2 4 6 8 10 12 14 16 1 3 5 7 9 11 13 15 2 4 6 8 10 12 14 16 1 3 5 7 9 11 13 15
Gain_PA	1.0[40]

References

1. 3GPP Technical Specification TS 25.222 V4.4.0, Multiplexing and channel coding (TDD) Release 4.
2. 3GPP Technical Specification TS 25.102 V4.5.0, UE Radio Transmission and Reception (TDD) Release 4.
3. 3GPP Technical Specification TS 25.105 V4.5.0, BS Radio transmission and Reception (TDD) Release 4.

TDSCDMA_RefCh_RF



Description RF reference measurement channel
 Library TDSCDMA, Fully Coded Source
 Class TSDFTDSCDMA_RefCh_RF

Parameters

Name	Description	Default	Unit	Type	Range
ROut	output resistance	DefaultROut	Ohm	real	(0, ∞)
FCarrier	carrier frequency	1900MHz	Hz	real	(0, ∞)
VRef	reference voltage	0.5222V	V	real	(0, ∞)
Power	modulator output power	0.1W	W	real	
FilterLength	length of raised cosine filters in number of symbols	16		int	(0, ∞)

Advanced Design System 2008

SamplesPerSymbol	samples per symbol period	8		int	
Link	link selection: Downlink, Uplink	Downlink		enum	
RefCh	reference channel selection indicator: CH_12.2k_MultiCode, CH_12.2k_SingleCode, CH_64k, CH_144k, CH_384k	CH_12.2k_MultiCode		enum	
PhyChNum_SA	physical channel allocation configuration	0 0 2 0 0 0 0		int array	[0, 16] for Downlink, [0, 2] for Uplink
MaxPhyChNum	sum of allocated physical channel in all slots	2		int	[1, 112]
ModType_SA	type of modulation of all slots, 0 for QPSK, 1 for 8PSK	0 0 0 0 0 0 0		int array	{0, 1}
TFCI_SA	allocated TFCI transmitted active slots configuration	0 0 1 0 0 0 0		int array	{0, 1}
TFCI_Length_SA	length of TFCI of all slots	0 0 16 0 0 0 0		int array	{0, 4, 8, 16, 32} for QPSK, {0, 6, 12, 24, 48} for 8PSK
SS_TPC_SA	type of SS and TPC of all slots	2 2 1 2 2 2 2		int array	{1, 2, 3}
MinSF_PA	minimum spreading factor array corresponding to allocated physical channels	16 16		int array	{1, 16} for Downlink, {1, 2, 4, 8, 16} for Uplink
SpreadCode_PA	index of OVSF code corresponding to allocated physical channels	1 2		int array	

BasicMidambleID	index of basic midamble	0		int	
K_SA	maximum number of midamble shifts in a cell for all slots	16 16 16 16 16 16 16		int array	
MidambleID_SA	index of midamble for all slots	5 5 5 5 5 5		int array	
Gain_PA	gain setting array corresponding to allocated physical channels	1.0 1.0		real array	

Pin Outputs

Pin	Name	Description	Signal Type
1	sig	output signal	timed
2	bits	information bits	int

Notes/Equations

1. This subnetwork implements RF reference measurement channel. The schematic for this subnetwork is shown in the following figure.

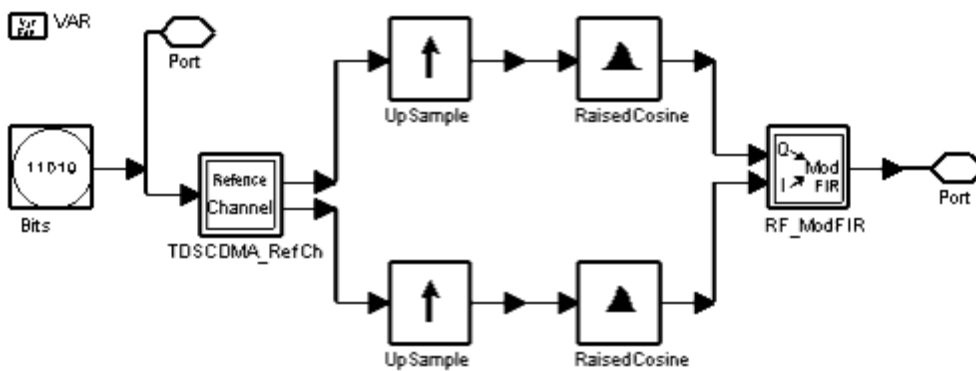

TDSCDMA_RefCh_RF Schematic

2. This subnetwork supports both uplink and downlink channels with data rates from 12.2k to 384k. VRef must be set according to data rate in order to obtain the desired output power. Parameter settings for reference channel can be referred to the TDSCDMA_RefCh.

Measurements for TD-SCDMA Design Library

TDSCDMA_BER



Description BER and BLER measurement
 Library TDSCDMA, Measurements
 Class SDFTDSCDMA_BER

Parameters

Name	Description	Default	Type	Range
BlockLength	block length	244	int	[1, 5000]
IgnoreNumber	number of initially ignored firings	0	int	[0, 1000]

Pin Inputs

Pin	Name	Description	Signal Type
1	input1	input data 1	int
2	input2	input data 2	int

Pin Outputs

Pin	Name	Description	Signal Type
3	BER	bit error rate	real
4	BLER	block error rate	real
5	BlkNum	number of blocks	int

Notes/Equations

- This model is used to measure BER and BLER.
Each firing, 1 BER token, 1 BLER token and 1 Block token are produced when BlockLength Input1 and Input2 Output tokens are consumed.

TDSCDMA_Constellation

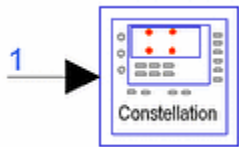

Description Constellation of received data
Library TDSCDMA, Measurements
Class TSDFTDSCDMA_Constellation

Parameters

Name	Description	Default	Unit	Type	Range
RLoad	reference resistance	DefaultRIn	Ohm	real	$(0, \infty)$
RTemp	temperature of reference resistor, in degrees C	DefaultRTemp		real	$[-273.15, \infty)$
FCarrier	carrier frequency	1900MHz	Hz	real	$\{-1\}$ or $(0, \infty)^+$
AnalysisTimeslot	timeslot to be analyzed: TS0, TS1, TS2, TS3, TS4, TS5, TS6	TS2		enum	
SamplesPerSymbol	samples per symbol	8		int	$[1, 32]$
FilterLength	length of raised cosine filters in number of symbols	16		int	$(0, \infty)$

SubframesToMeasure	number of subframes to be measured	1		int	[1, 65535]
SyncCodeUsed	Code used in synchronization: DwPTS, UpPTS, Midamble	DwPTS		enum	
SyncCodeIdx	index of basic synchronization code	0		int	[0, 31] when SyncCodeUsed=DwPTS; [0, 255] when SyncCodeUsed=UpPTS
ModPhase	type of modulation quadruples, valid only in downlink: S1, S2	S1		enum	
MidambleAllocScheme	midamble allocation scheme: UE_Specific, Common, Default	Default		enum	
BasicMidambleID	index of basic midamble	0		int	[0, 127]
K	maximum number of midamble shifts in a cell	16		int	{2, 4,6,8,10,12,14,16}
MidambleID	index of midamble	1		int	[1, K]
SpreadFactor	spreading factor	16		int	{1, 2,4,8,16}
SpreadCode	index of spread code	1		int	[1, SpreadFactor]
PhyChNum	number of channelization codes used in a timeslot	1		int	[1, 16]

† The FCarrier parameter sets the internal oscillator frequency used for demodulation. Setting FCarrier to -1 will use the input signal characterization frequency as the internal oscillator frequency.

Pin	Name	Description	Signal Type
1	in	input signals	timed

Notes/Equations

- This subnetwork is used to measure the TDSCDMA signal constellation. The schematic for this subnetwork is shown in the following figure.

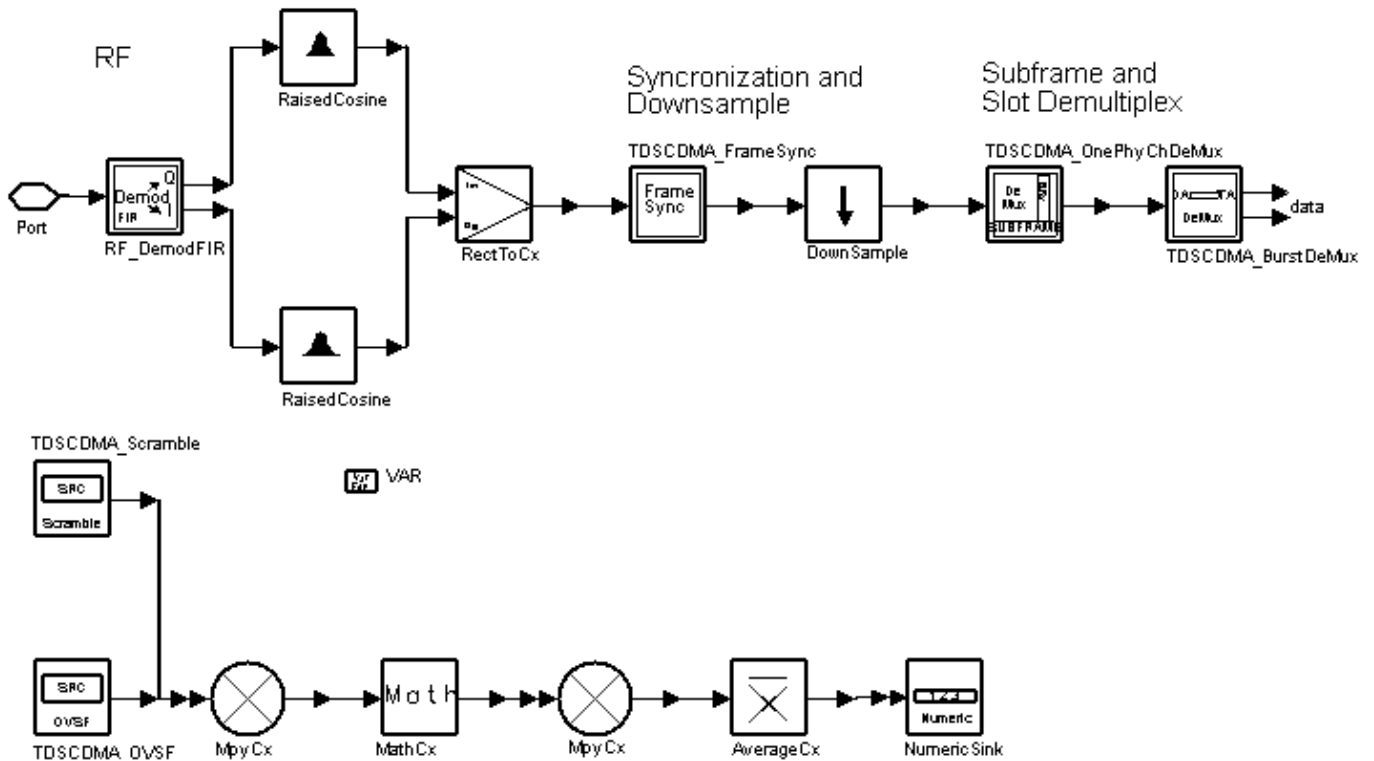

TDSCDMA_Constellation Schematic

- The TDSCDMA input signal delay is introduced by the filter (or device under test). The maximum delay that can be detected is the length of one subframe.
- The received signal is synchronized and the information data is separated from the analyzed timeslot set by the AnalysisTimeslot parameter; the modulated symbols are despread from the information data and stored as a complex number. The constellation is determined by drawing the imaginary vs. the real part of the complex data stored.
- AnalysisTimeslot specifies which timeslot is analyzed in the current measurement. It is also used to determine the frame boundary during synchronization when SyncCodeUsed is set to Midamble.
- A raised-cosine filter is used in this subnetwork. FilterLength specifies the length of the filter; set this parameter to the same value as the signal source filter.
- SyncCodeUsed specifies the synchronization code.
 - DwPTS (downlink pilot codes) SyncCodeIdx and ModPhase synchronization-code-related parameters must be set.

- UpPTS (uplink pilot codes) SyncCodeIdx synchronization-code-related parameter must be set.
- Midamble (midamble codes) MidambleAllocScheme, BasicMidambleID, K, MidambleID, PhyChNum, SpreadFactor and SpreadCode synchronization-code-related parameters must be set.

References

1. 3GPP TS 25.221, 3rd Generation Partnership Project; Technical Specification Group Radio Access Network; Physical channels and mapping of transport channels onto physical channels onto physical channels (TDD) (Release 4), version 4.3.0, Dec., 2001.

TDSCDMA_EVM



Description EVM measurement
 Library TDSCDMA, Measurements
 Class TSDF_TDSCDMA_EVM

Parameters

Name	Description	Default	Unit	Type	Range
RLoad	load resistance. DefaultRLoad will inherit from the DF controller.	DefaultRLoad	Ohm	real	(0, ∞)
RTemp	physical temperature, in degrees C, of load resistance. DefaultRTemp will inherit from the DF controller.	DefaultRTemp	Celsius	real	[-273.15, ∞)

Advanced Design System 2008

FCarrier	carrier frequency	1.9e9	Hz	real	(0, ∞)
Start	start time for data recording. DefaultTimeStart will inherit from the DF Controller.	DefaultTimeStart	sec	real	[0, ∞)
AverageType	average type: OFF, RMS (Video)	OFF		enum	
SubframesToAverage	number of subframes that will be averaged if AverageType is RMS (Video)	10		int	[1, ∞)
ChipRate	chip rate	1.28e6	Hz	real	(0, ∞)
Alpha	root raised cosine filter roll off factor	0.22		real	[0.05, 1]
MirrorFrequencySpectrum	mirror frequency spectrum: NO, YES	NO		enum	
ActiveSlotThreshold	power level (in dB with respect to the power level of the slot with largest measured power) threshold for active slot identification	-30.0		real	[-120, 0]
DownlinkPilotCode	downlink pilot code	0		int	[0, 31]
UplinkPilotCode	uplink pilot code	0		int	[0, 255]
ScrambleCode	scramble code	0		int	[0, 127]
BasicMidambleID	basic midamble code	0		int	[0, 127]
TrafficTimeslotMaxUsers	maximum number of users for each timeslot	8 16 16 16 16 16 16		int array	{2, 4, 6, 8, 10, 12, 14, 16}†
DespreadCodeLength	spreading code length of the channel to be analyzed:	Length16		enum	

Advanced Design System 2008

	Length16, Length8, Length4, Length2, Length1				
DespreadCodeChannel	spreading code of the channel to be analyzed	1		int	[1, DespreadCodeLength]
AnalysisTimeslot	timeslot to be analyzed: TS0, TS1, TS2, TS3, TS4, TS5, TS6, DwPTS, UpPTS	TS0		enum	
† for each element of the array; array size must be 7.					

Pin Inputs

Pin	Name	Description	Signal Type
1	input	input signal	timed

Notes/Equations

- This model performs an EVM measurement for a TD-SCDMA signal. The input signal must be a timed RF (complex envelope) signal or else the model will error out. The available results from this measurement are:
 - Avg_ChEVMrms_pct: average channel EVM rms in %
 - ChEVMrms_pct: channel EVM rms in % versus subframe
 - ChEVM_Pk_pct: channel peak EVM in % versus subframe
 - ChEVM_Pk_symbol_idx: channel peak EVM symbol index versus subframe
 - Avg_ChMagErr_rms_pct: average channel magnitude error rms in %
 - ChMagErr_rms_pct: channel magnitude error rms in % versus subframe
 - ChMagErr_Pk_pct: channel peak magnitude error in % versus subframe
 - ChMagErr_Pk_symbol_idx: channel peak magnitude error symbol index versus subframe
 - Avg_ChPhaseErr_deg: average channel phase error in degrees
 - ChPhaseErr_deg: channel phase error in degrees versus subframe
 - ChPhaseErr_Pk_deg: channel peak phase error in degrees versus subframe
 - ChPhaseErr_Pk_symbol_idx: channel peak phase error symbol index versus subframe
 - ChCodePhase_deg: channel code phase (phase of the channel code with respect to the pilot) versus subframe
 - Avg_CompEVMrms_pct: average composite EVM rms in %
 - CompEVMrms_pct: composite EVM rms in % versus subframe
 - CompEVM_Pk_pct: composite peak EVM in % versus subframe
 - CompEVM_Pk_chip_idx: composite peak EVM chip index versus subframe
 - Avg_CompMagErr_rms_pct: average composite magnitude error rms in %
 - CompMagErr_rms_pct: composite magnitude error rms in % versus subframe

Advanced Design System 2008

- CompMagErr_Pk_pct: composite peak magnitude error in % versus subframe
- CompMagErr_Pk_chip_idx: composite peak magnitude error chip index versus subframe
- Avg_CompPhaseErr_deg: average composite phase error in degrees
- CompPhaseErr_deg: composite phase error in degrees versus subframe
- CompPhaseErr_Pk_deg: composite peak phase error in degrees versus subframe
- CompPhaseErr_Pk_chip_idx: composite peak phase error chip index versus subframe
- Avg_Rho: average rho
- Rho: rho versus subframe
- Avg_FreqError_Hz: average frequency error in Hz
- FreqError_Hz: frequency error in Hz versus subframe
- Avg_IQ_Offset_dB: average IQ offset in dB
- IQ_Offset_dB: IQ offset in dB versus subframe
- Avg_QuadErr_deg: average quadrature error in degrees
- QuadErr_deg: quadrature error in degrees versus subframe
- Avg_GainImb_dB: average IQ gain imbalance in dB
- GainImb_dB: IQ gain imbalance in dB versus subframe

Results named with the Avg_ prefix are results averaged over the number of subframes specified by the user (if AverageType is set to RMS (Video)). Results that are not named Avg_ are results versus subframe.

To use any of the results in an ael expression or in the Goal expression in an optimization setup, you must prefix them with the instance name of the model followed by a dot, for example T1.Avg_CompEVMrms_pct .

2. The following is a brief description of the algorithm used in this model and details of its parameter usage. Starting at the time instant specified by the Start parameter, the model captures a signal segment of 10 msec and detects the beginning of a subframe (a 10 msec signal segment is guaranteed to contain a whole subframe). After the subframe is detected, the I and Q envelopes of the input signal are extracted. The FCarrier parameter sets the frequency of the internal local oscillator signal for the I and Q envelope extraction. Finally, the I and Q envelopes are passed to a complex algorithm that performs synchronization, demodulation, and EVM analysis. The algorithm that performs the synchronization, demodulation, and EVM analysis is the same as the one used in the Agilent 89600 VSA.
3. If AverageType is set to OFF, only one subframe is detected, demodulated, and analyzed. If AverageType is set to RMS (Video), after the first subframe is analyzed the signal segment corresponding to it is discarded and new signal samples are collected from the input to fill in the 10 msec-long signal buffer. When the buffer is full again a new subframe is detected, demodulated, and analyzed. These steps are repeated until SubframesToAverage subframes are processed. If, for any reason, a subframe is mis-detected, the results from its analysis are discarded. The EVM results obtained from all the successfully detected, demodulated, and analyzed subframes are averaged to give the final averaged results. The EVM results from each successfully analyzed subframe are also recorded (in the variables without the Avg_ prefix in their name).
4. The ChipRate parameter can be used to set the chip rate for the demodulation. Although the TD-SCDMA standard defines the chip rate to be 1.28 MHz, this parameter allows the user to enter nonstandard chip rates for test and analysis purposes. Of course, in order for the demodulation to be successful, the value of the ChipRate parameter must match the actual chip rate of the input signal.
5. The Alpha parameter can be used to set the measurement filter (root-raised cosine) alpha factor. Although the TD-SCDMA standard defines alpha to be 0.22, this parameter allows the user to enter nonstandard alpha values for test and analysis purposes. However, in order to get correct EVM results, the value of the Alpha parameter must match the alpha value used to generate the input signal.
6. The MirrorFrequencySpectrum parameter can be used to conjugate the input signal (when MirrorFrequencySpectrum is set to YES) before any other processing is done. Conjugating the input signal is necessary if the configuration of the mixers in your system has resulted in a conjugated signal compared to the one at the input of the up-converter. In this case, if MirrorFrequencySpectrum is not set to YES, the demodulation will fail.

Advanced Design System 2008

7. The ActiveSlotThreshold parameter sets the active slot detection threshold, that is the power level (in dB with respect to the power level of the slot with the largest measured power) below which a slot will be considered as inactive.
8. The following table gives TD-SCDMA standard compliant allocations for downlink pilot, uplink pilot, scrambling, and basic midamble codes for the different code groups.

Associated Codes

Code Group	DownlinkPilotCode	UplinkPilotCode	ScrambleCode	BasicMidambleID
Group1	0	0-7	0 1 2 3	0 1 2 3
Group 2	1	8-15	4 5 6 7	4 5 6 7
. . .				
Group 32	31	248-255	124 125 126 127	124 125 126 127

- The DownlinkPilotCode parameter sets the downlink pilot synchronization ID sequence (SYNC-DL). Downlink pilot synchronization (DwPTS) is used for DL synchronization and cell initial search. There are 32 different SYNC-DL code groups, which are used to distinguish base stations.
 - The UplinkPilotCode parameter sets the uplink pilot synchronization ID sequence (SYNC-UL). Uplink pilot synchronization (UpPTS) is used for UL initial synchronization, random access and measurement for adjacent cell handoff. There are 256 different SYNC-UL codes, which can be divided into 32 groups. Each group includes 8 different SYNC-UL codes, i.e., each base station has 8 different SYNC-UL codes. For test and analysis purposes UplinkPilotCode can be set to non-standard-compliant values (that do not follow the allocation scheme given in the previous table). However, in this case a warning message is displayed to remind the user that the value used is non-compliant.
 - The ScrambleCode parameter sets the scramble code ID. There are 128 different scrambling codes, which are associated with a corresponding basic midamble code. Scrambling codes are cell specific and are used to identify separate cells. For test and analysis purposes ScrambleCode can be set to non-standard-compliant values (that do not follow the allocation scheme given in the previous table). However, in this case a warning message is displayed to remind the designer that the value used is non-compliant.
 - The BasicMidambleID parameter sets the basic midamble code ID. The basic midamble code ID is used as training sequences for uplink and downlink channel estimation, power measurements and maintaining uplink synchronization. There are 128 different sequences divided into 32 groups corresponding to 32 SYNC-DL codes. Each group consists of 4 different basic midamble sequences, i.e. each base station has 4 different midambles. For test and analysis purposes BasicMidambleID can be set to non-standard-compliant values (that do not follow the allocation scheme given in the previous table). However, in this case a warning message is displayed to remind the designer that the value used is non-compliant.
9. The TrafficTimeslotMaxUsers parameter sets the maximum number of users in each timeslot (TS0 - TS6). This parameter is an array with 7 elements. If the number of elements specified is not exactly 7, the simulation will error out. Each array element must be an even number greater than or equal to 2 and smaller than or equal to 16.
 10. The DespreadCodeLength and DespreadCodeChannel parameters can be used to specify the active code layer and channel for which channel EVM results will be provided.
 11. The AnalysisTimeslot parameter can be used to specify which timeslot in the detected subframe will be analyzed. The available options are: timeslots 0 through 6 (TS0 - TS6), DwPTS, and UpPTS. When DwPTS or UpPTS is selected the results do not include any channel specific measurements (variables whose name starts with Ch or

Avg_Ch), which means that the values of the DespreadCodeLength and DespreadCodeChannel parameters are ignored (not used).

TDSCDMA_FrameSync

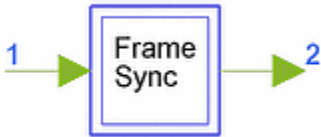

Description Synchronized frame generator
 Library TDSCDMA, Measurements
 Class SDFTDSCDMA_FrameSync

Parameters

Name	Description	Default	Type	Range
AnalysisTimeslot	timeslot to be analyzed: TS0, TS1, TS2, TS3, TS4, TS5, TS6	TS2	enum	
SamplesPerSymbol	samples per symbol	8	int	[1, 32]
SyncCodeUsed	Code used in synchronization: DwPTS, UpPTS, Midamble	DwPTS	enum	
SyncCodeIdx	index of basic synchronization code	0	int	[0, 31] when SyncCodeUsed=DwPTS; [0, 255] when SyncCodeUsed=UpPTS
ModPhase	type of modulation quadruples, valid only in downlink: S1, S2	S1	enum	
MidambleAllocScheme	midamble allocation scheme: UE_Specific, Common, Default	Default	enum	
BasicMidambleID	index of basic midamble	0	int	[0, 127]
K	maximum number of	16	int	{2,

Advanced Design System 2008

	midamble shifts in a cell			4,6,8,10,12,14,16}
MidambleID	index of midamble	1	int	[1, K]
SpreadFactor	spreading factor	16	int	{1, 2,4,8,16}
SpreadCode	index of spread code	1	int	[1, SpreadFactor]
PhyChNum	number of channelization codes used in a timeslot	1	int	[1, 16]

Pin Inputs

Pin	Name	Description	Signal Type
1	DataI	input data	complex

Pin Outputs

Pin	Name	Description	Signal Type
2	DataO	output data	complex

Notes/Equations

1. This subnetwork is used to synchronize the TDSCDMA signal frame-by-frame using pilot code or midamble code to find the first sample of the first frame and align the signal to the subframe boundary. Each firing, the subnetwork will consume data in one subframe length, buffer data in two subframe lengths, and produce a synchronized signal in one subframe length. The schematic for this subnetwork is shown in the following figure.

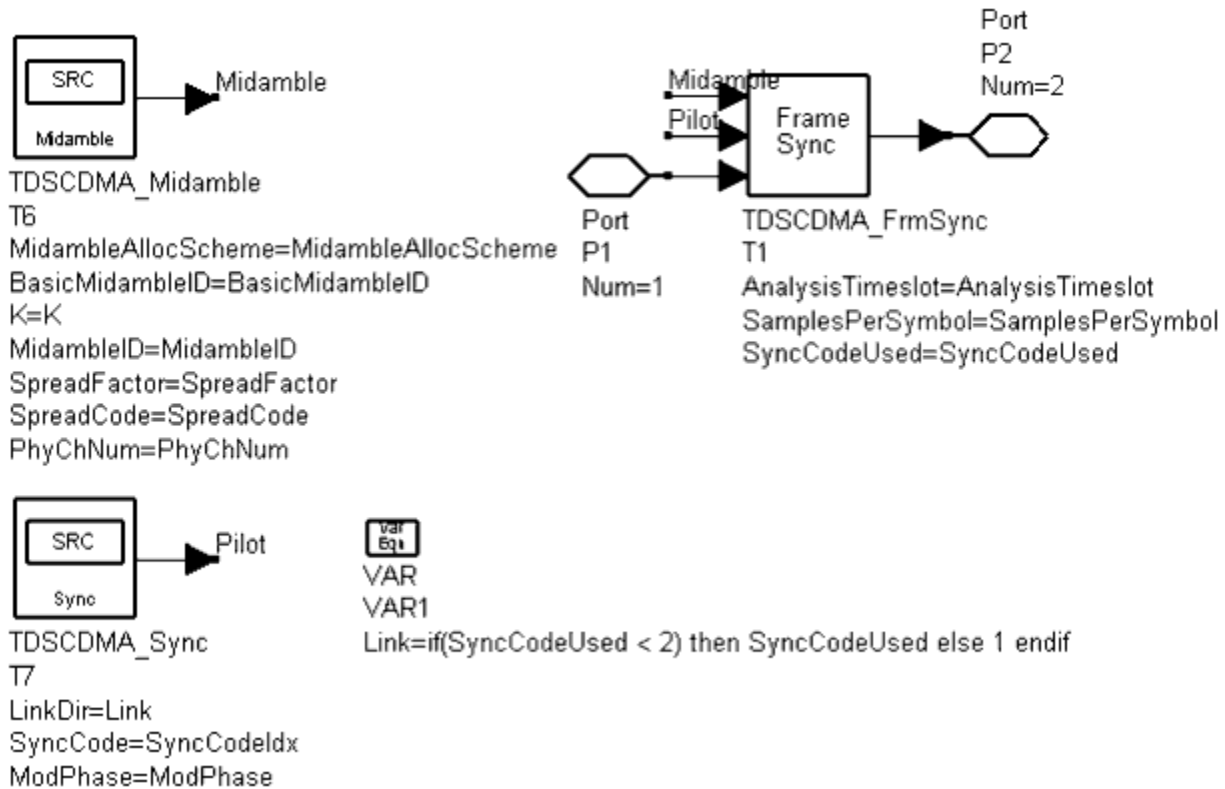

TDSCDMA_FrameSync Schematic

2. The TDSCDMA input signal delay is introduced by a filter or device under test. The maximum delay that can be detected by this subnetwork is the length of one subframe. This model introduces an additional one-subframe delay that is padded with all zeros.
3. Synchronization is achieved by correlating the signals with the pilot codes or the midamble codes depending on the SyncCodeUsed setting. The largest correlation value is used to determine the synchronization point. Because the position of the pilot codes and midamble codes of a specific timeslot is fixed in each subframe, the frame boundary is determined easily.
4. SyncCodeUsed specifies the synchronization code.
 - DwPTS (downlink pilot codes) SyncCodeIdx and ModPhase synchronization-code-related parameters must be set.
 - UpPTS (uplink pilot codes) SyncCodeIdx synchronization-code-related parameter must be set.
 - Midamble (midamble codes) MidambleAllocScheme, BasicMidambleID, K, MidambleID, PhyChNum, SpreadFactor and SpreadCode synchronization-code-related parameters must be set.
5. AnalysisTimeslot determines the frame boundary when the maximum correlated value is found; set AnalysisTimeslot only if SyncCodeUsed is set to Midamble.

References

1. 3GPP TS 25.221, 3rd Generation Partnership Project; Technical Specification Group Radio Access Network; Physical channels and mapping of transport channels onto physical channels (TDD) (Release 4), version 4.3.0, Dec., 2001.

TDSCDMA_RF_CCDF

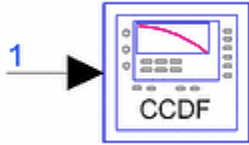

Description RF signal complementary cumulative distribution function

Library TDSCDMA, Measurements

Class TSDFTDSCDMA_RF_CCDF

Parameters

Name	Description	Default	Unit	Type	Range
RLoad	reference resistance	DefaultRIn	Ohm	real	$(0, \infty)$
RTemp	temperature of reference resistor, in degrees C	DefaultRTemp		real	$[-273.15, \infty)$
SamplesPerSymbol	samples per symbol	8		int	[1, 32]
SlotIndex	index of slot	2		int	[0, 6]
NumSlotsMeasured	number of slot to be measured	5		int	[1, 300]
OutputPoint	indicate output precision	100		int	[3, 100]
SystemDelay	delay due to filters	64		int	$[0, \infty)$

Pin Inputs

Pin	Name	Description	Signal Type
1	in	input signals	timed

Notes/Equations

1. This subnetwork measures the complementary cumulative distribution function (CCDF) of the RF signal.

The schematic for this subnetwork is shown in the following figure.

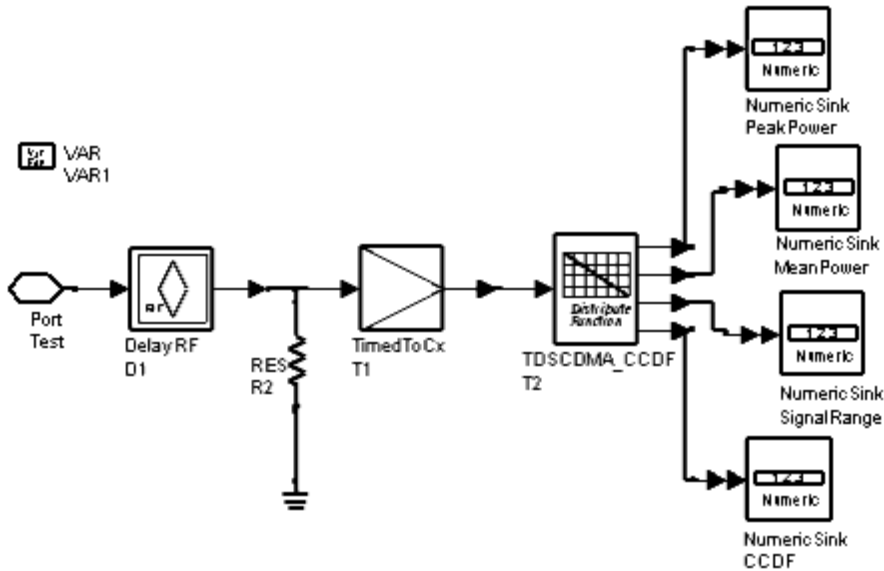

TDSCDMA_RF_CCDF Schematic

2. TDSCDMA_RF_CCDF measures the distribution function according to input signal power; results are collected by four NumericSink models. The distribution range is sent to the SignalRange NumericSink; here the distribution range is divided into segments (based on the OutputPoint setting). Corresponding distribution probabilities are measured on these segments and sent to the CCDF NumericSink.

NumericSinks PeakPower, MeanPower and SignalRange units are dBm

3. SlotIndex indicates which slot in a frame will be measured; CCDF can be measured on several time slots. The slots with No. SlotIndex in NumSlotsMeasured consecutive subframes are combined to get more precise results.
4. The signal is regarded as subframe-synchronized. SystemDelay indicates the number of delay in samples caused by filters and other devices. If the delay is not a multiple of subframe, extra delay will be added in DelayRF so that the test begins at the first effective data.

References

1. 3GPP TS 25.221, 3rd Generation Partnership Project; Technical Specification Group Radio Access Network; Physical channels and mapping of transport channels onto physical channels (TDD) (Release 4), version 4.3.0, Dec., 2001.

TDSCDMA_RF_PwrMeasure

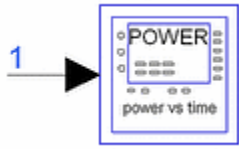

Description: RF power meter

Library: TDSCDMA, Measurements

Class: TSDFTDSCDMA_RF_PwrMeasure

Parameters

Name	Description	Default	Unit	Type	Range
RLoad	reference resistance	DefaultRIn	Ohm	real	(0, ∞)
RTemp	temperature of reference resistor, in degrees C	DefaultRTemp		real	[-273.15, ∞)
FCarrier	carrier frequency	1900MHz	Hz	real	(0, ∞)
AnalysisTimeslot	timeslot to be analyzed: TS0, TS1, TS2, TS3, TS4, TS5, TS6	TS2		enum	
SamplesPerSymbol	samples per symbol	8		int	[1, 32]
FilterLength	length of raised cosine filters in number of symbols	16		int	(0, ∞)
NumSlotsMeasured	number of slot to be measured	3		int	[1, 300]
SyncCodeUsed	Code used in synchronization: DwPTS, UpPTS, Midamble	DwPTS		enum	
SyncCodeIdx	index of basic synchronization code	0		int	[0, 31] when SyncCodeUsed=DwPTS; [0, 255] when SyncCodeUsed=UpPTS
ModPhase	type of modulation	S1		enum	

Advanced Design System 2008

	quadruples, valid only in downlink: S1, S2				
MidambleAllocScheme	midamble allocation scheme: UE_Specific, Common, Default	Default		enum	
BasicMidambleID	index of basic midamble	0		int	[0, 127]
K	maximum number of midamble shifts in a cell	16		int	{2, 4, 6, 8, 10, 12, 14, 16}
MidambleID	index of midamble	1		int	[1, K]
SpreadFactor	spreading factor	16		int	{1, 2, 4, 8, 16}
SpreadCode	index of spread code	1		int	[1, SpreadFactor]
PhyChNum	number of channelization codes used in a timeslot	1		int	[1, 16]

Pin Inputs

Pin	Name	Description	Signal Type
1	in	input signals	timed

Notes/Equations

1. This subnetwork measures the average power and power vs. time of the RF signal. The schematic for this subnetwork is shown in the following figure.

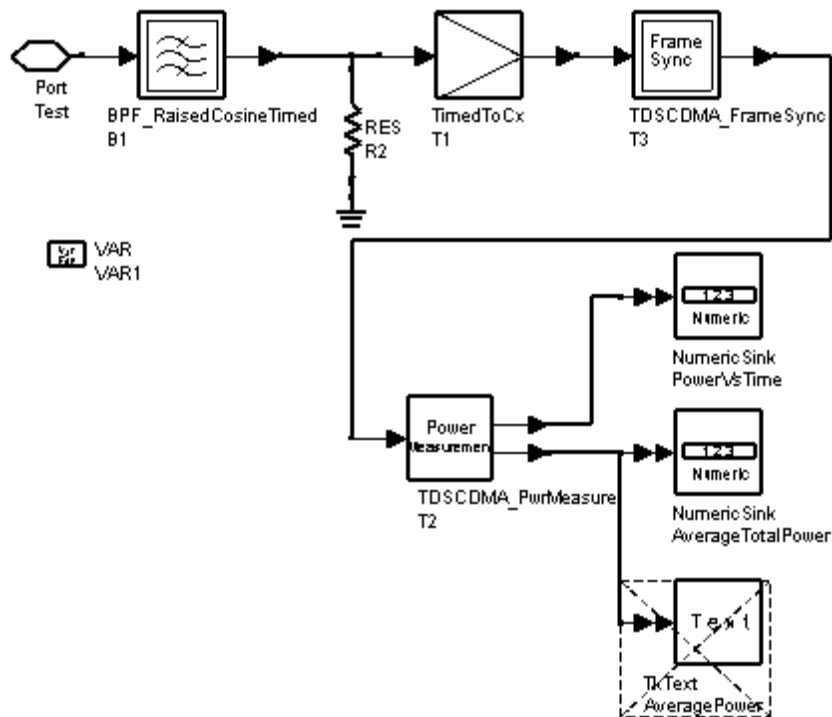

TDSCDMA_RF_PwrMeasure Schematic

2. There are two outputs.

- One output is the average power for each time slot GP, DwPTS and UpPTS. Ten values will be fed into NumericSink AverageTotalPower (see the previous figure). They are average power for Slot 0, DwPTS, GP, UpPTS, Slot 1 to Slot 6 sequentially. The power of one slot can be averaged with correspondent slots in NumSlotsMeasured subframes. For example, if NumSlotsMeasured is 8 the average power of Slot 1 will be the average power of Slot 1 in all 8 subframes. Note that the GP part in each slot will not be counted when measuring the average power.
- One output is the average power of each chip in one subframe. 6400 values will be fed into NumericSink PowerVsTime (see the previous figure). The power of each chip will be averaged with correspondent chips in NumSlotsMeasured subframes.

3. NumericSinks PowerVsTime and AverageTotalPower units are dBm.

4. SyncCodeUsed specifies the synchronization code.

- DwPTS (downlink pilot codes) SyncCodeIdx and ModPhase synchronization-code-related parameters must be set.
- UpPTS (uplink pilot codes) SyncCodeIdx synchronization-code-related parameter must be set.
- Midamble (midamble codes) MidambleAllocScheme, BasicMidambleID, K, MidambleID, PhyChNum, SpreadFactor and SpreadCode synchronization-code-related parameters must be set.

5. AnalysisTimeslot determines the frame boundary when the maximum correlated value is found; set AnalysisTimeslot only if SyncCodeUsed is set to Midamble.

References

1. 3GPP TS 25.221, 3rd Generation Partnership Project; Technical Specification Group Radio Access Network; Physical channels and mapping of transport channels onto physical channels (TDD) (Release 4), version 4.3.0, Dec., 2001.

Modems for TD-SCDMA Design Library

TDSCDMA_BurstDeMux



Description Burst demultiplexer
 Library TDSCDMA, Modems
 Class SDFTDSCDMA_BurstDeMux

Parameters

Name	Description	Default	Type	Range
K	maximum number of midamble shifts in a cell	16	int	{2, 4,6,8,10,12,14,16}

Pin Inputs

Pin	Name	Description	Signal Type
1	input	input	complex

Pin Outputs

Pin	Name	Description	Signal Type
2	data	data output	complex
3	mid	midamble output	complex

Notes/Equations

- This subnetwork is used to demultiplex data and midamble from a burst. The schematic for this subnetwork is shown in the following figure. Each firing, 864 tokens are consumed while $(352+W) \times 2$ data tokens and 144 midamble tokens are produced, where $W=128/K$, which is the channel estimation window length.

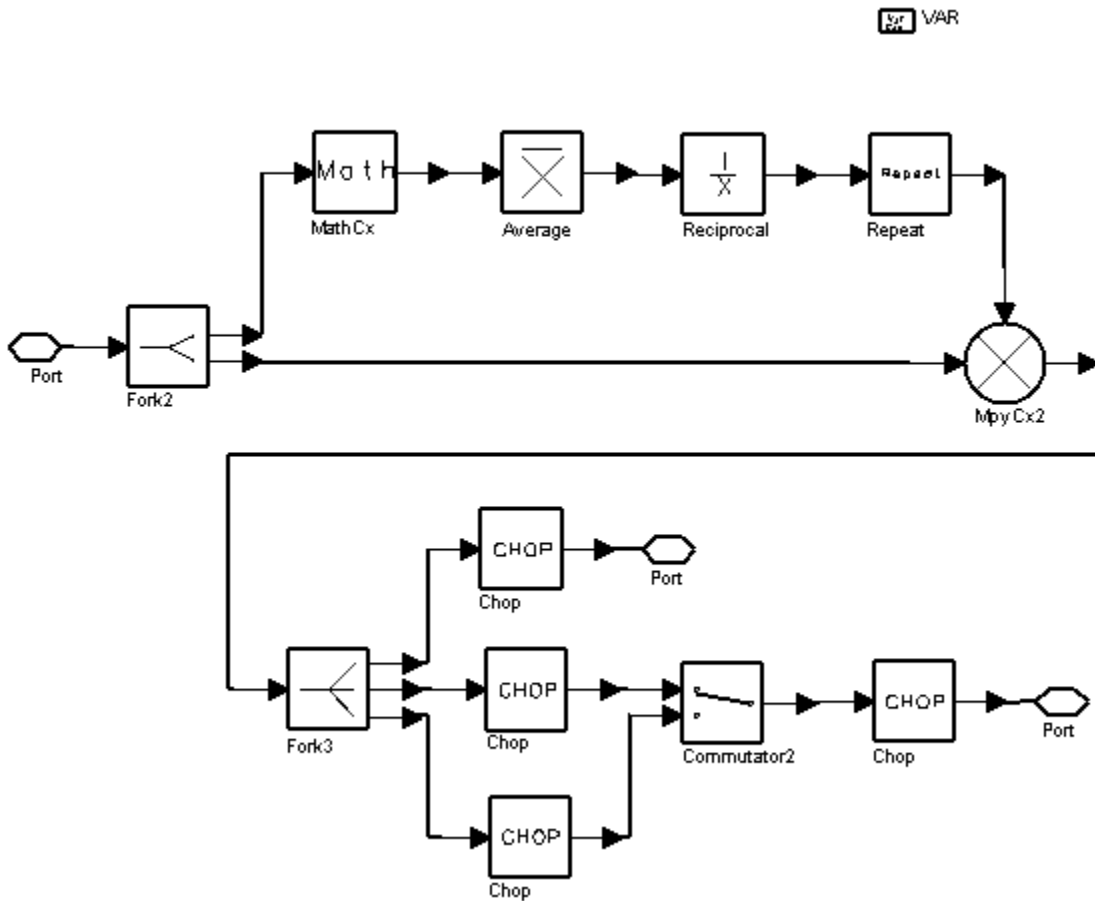

TDSCDMA_BurstDeMux Schematic

The burst structure is illustrated in the following figure.

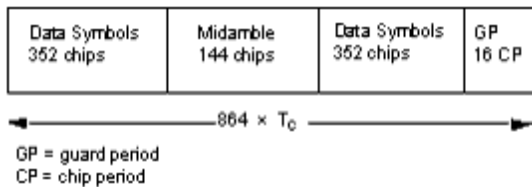

Burst Structure of Traffic Burst Format

References

1. 3GPP TS 25.221, 3rd Generation Partnership Project; Technical Specification Group Radio Access Network; Physical channels and mapping of transport channels onto physical channels (TDD) (Release 4), version 4.5.0, Dec., 2001.

TDSCDMA_BurstMux



Description Burst multiplexer
 Library TDSCDMA, Modems
 Class SDFTDSCDMA_BurstMux

Pin Inputs

Pin	Name	Description	Signal Type
1	Data	data	complex
2	Midamble	midamble	complex

Pin Outputs

Pin	Name	Description	Signal Type
3	Output	burst	complex

Notes/Equations

1. This model multiplexes data and midamble and forms a burst.
 Each firing, 864 Output tokens are produced when 704 Data tokens and 144 Midamble tokens are consumed.
2. The burst structure of the traffic burst format is illustrated in the following figure.

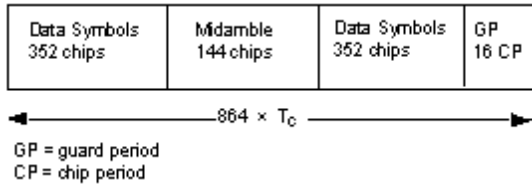

Burst Structure of Traffic Burst Format

References

1. 3GPP TS 25.221, 3rd Generation Partnership Project; Technical Specification Group Radio Access Network; Physical channels and mapping of transport channels onto physical channels (TDD) (Release 4), version 4.3.0, Dec., 2001.

TDSCDMA_Demodulator



Description QPSK, 8PSK demodulator
Library TDSCDMA, Modems
Class SDFTDSCDMA_Demodulator

Parameters

Name	Description	Default	Type
ModType	type of modulation: QPSK, _8PSK	QPSK	enum
Decision	decision method of Viterbi or Turbo decoder: Soft decision, Hard decision	Soft decision	enum

Pin Inputs

Pin	Name	Description	Signal Type
-----	------	-------------	-------------

Advanced Design System 2008

1	Input	input data from receiver	complex
---	-------	--------------------------	---------

Pin Outputs

Pin	Name	Description	Signal Type
2	Output	output decision values	real

Notes/Equations

- This component is used to perform demodulation for QPSK, 8PSK and provide hard- or soft-decision values for Viterbi decoder or Turbo decoder.
Each firing, 2 Output tokens for QPSK, 3 Output tokens for 8PSK are produced when 1 Input token is consumed.

References

- 3GPP TS 25.223, 3rd Generation Partnership Project; Technical Specification Group Radio Access Network: Spreading and Modulation (TDD) (Release 4), version 4.5.0, June 2002.

TDSCDMA_DPCH_DataDeMux



Description DeMultiplexer for data, TFCI, SS, and TPC in DPCH
 Library TDSCDMA, Modems
 Class SDFTDSCDMA_DPCH_DataDeMux

Parameters

Name	Description	Default	Type
BitsPerSlot	number of bits per slot	88	int
N_Data1	number of data bits in the first data field	44	int

Advanced Design System 2008

N_Data2	number of data bits in the second data field	44	int
N_TFCI1	number of TFCI bits in the first TFCI field	0	int
N_TFCI2	number of TFCI bits in the second TFCI field	0	int
N_SS	number of SS bits in the slot	0	int
N_TPC	number of TPC bits in the slot	0	int

Pin Inputs

Pin	Name	Description	Signal Type
1	Input	input signal	real

Pin Outputs

Pin	Name	Description	Signal Type
2	Data	data of dedicated physical channel	real
3	TFCI	transport format combination indicator bits	real
4	SS	information bits for uplink synchronization control	real
5	TPC	transmit power control bits	real

Notes/Equations

1. This subnetwork is used to demultiplex data, TFCI bits, SS bits and TPC bits from a DPCH. The schematic for this subnetwork is shown in the following figure.

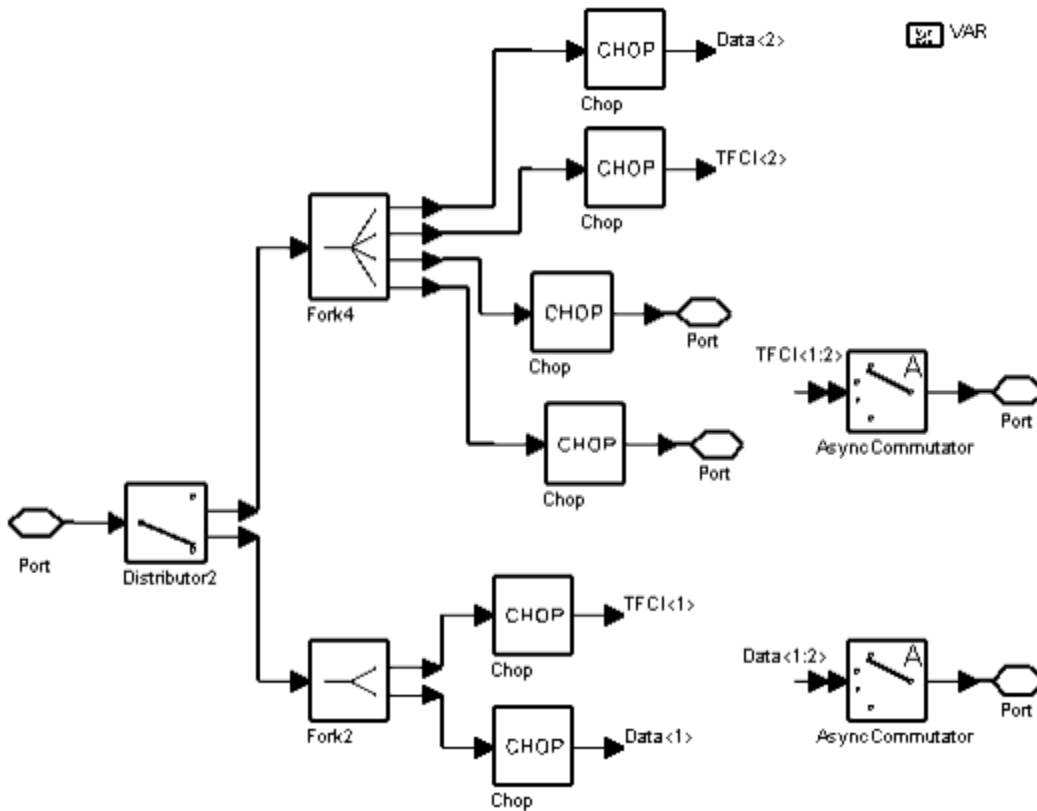

TDSCDMA_DPCH_DataDeMux Schematic

2. The structure of a typical slot is illustrated in the following figure.

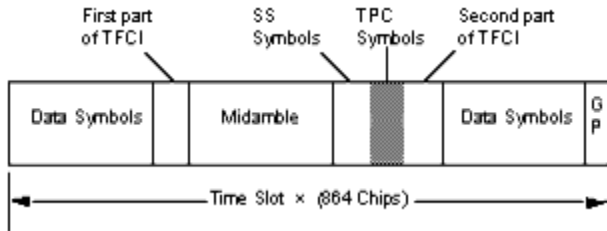

TDSCDMA Slot Structure

3. Time slot formats for the downlink with QPSK modulation are given in the first table; time slot formats for uplink with QPSK modulation are given in the second table; time slot formats for both links with 8PSK modulation are given in the third table.

Downlink Time Slot Formats

Slot Format #	Spread Factor	Midamble Length (chips)	NTFCI Code Word (bits)	NSS & NTPC (bits)	Bits/ Slot	NData/ Slot (bits)	Ndata/ Data Field (1) (bits)	Ndata/ Data Field (2) (bits)
0	16	144	0	0 & 0	88	88	44	44

Advanced Design System 2008

1	16	144	4	0 & 0	88	86	42	44
2	16	144	8	0 & 0	88	84	42	42
3	16	144	16	0 & 0	88	80	40	40
4	16	144	32	0 & 0	88	72	36	36
5	16	144	0	2 & 2	88	84	44	40
6	16	144	4	2 & 2	88	82	42	40
7	16	144	8	2 & 2	88	80	42	38
8	16	144	16	2 & 2	88	76	40	36
9	16	144	32	2 & 2	88	68	36	32
10	1	144	0	0 & 0	1408	1408	704	704
11	1	144	4	0 & 0	1408	1406	702	704
12	1	144	8	0 & 0	1408	1404	702	702
13	1	144	16	0 & 0	1408	1400	700	700
14	1	144	32	0 & 0	1408	1392	696	696
15	1	144	0	2 & 2	1408	1404	704	700
16	1	144	4	2 & 2	1408	1402	702	700
17	1	144	8	2 & 2	1408	1400	702	698
18	1	144	16	2 & 2	1408	1396	700	696
19	1	144	32	2 & 2	1408	1388	696	692
20	1	144	0	32 & 32	1408	1344	704	640
21	1	144	4	32 & 32	1408	1342	702	640
22	1	144	8	32 & 32	1408	1340	702	638
23	1	144	16	32 & 32	1408	1336	700	636
24	1	144	32	32 & 32	1408	1328	696	632

Uplink Time Slot Formats

Slot Format	Spread Factor	Midamble Length (chips)	NTFCI Code Word (bits)	NSS & NTPC (bits)	Bits/Slot	NData/Slot (bits)	Ndata/Data Field (1) (bits)	Ndata/Data Field (2) (bits)
0	16	144	0	0 & 0	88	88	44	44
1	16	144	4	0 & 0	88	86	42	44
2	16	144	8	0 & 0	88	84	42	42

Advanced Design System 2008

3	16	144	16	0 & 0	88	80	40	40
4	16	144	32	0 & 0	88	72	36	36
5	16	144	0	2 & 2	88	84	44	40
6	16	144	4	2 & 2	88	82	42	40
7	16	144	8	2 & 2	88	80	42	38
8	16	144	16	2 & 2	88	76	40	36
9	16	144	32	2 & 2	88	68	36	32
10	8	144	0	0 & 0	176	176	88	88
11	8	144	4	0 & 0	176	174	86	88
12	8	144	8	0 & 0	176	172	86	86
13	8	144	16	0 & 0	176	168	84	84
14	8	144	32	0 & 0	176	160	80	80
15	8	144	0	2 & 2	176	172	88	84
16	8	144	4	2 & 2	176	170	86	84
17	8	144	8	2 & 2	176	168	86	82
18	8	144	16	2 & 2	176	164	84	80
19	8	144	32	2 & 2	176	156	80	76
20	8	144	0	4 & 4	176	168	88	80
21	8	144	4	4 & 4	176	166	86	80
22	8	144	8	4 & 4	176	164	86	78
23	8	144	16	4 & 4	176	160	84	76
24	8	144	32	4 & 4	176	152	80	72
25	4	144	0	0 & 0	352	352	176	176
26	4	144	4	0 & 0	352	350	174	176
27	4	144	8	0 & 0	352	348	174	174
28	4	144	16	0 & 0	352	344	172	172
29	4	144	32	0 & 0	352	336	168	168
30	4	144	0	2 & 2	352	348	176	172
31	4	144	4	2 & 2	352	346	174	172
32	4	144	8	2 & 2	352	344	174	170
33	4	144	16	2 & 2	352	340	172	168
34	4	144	32	2 & 2	352	332	168	164

Advanced Design System 2008

35	4	144	0	8 & 8	352	336	176	160
36	4	144	4	8 & 8	352	334	174	160
37	4	144	8	8 & 8	352	332	174	158
38	4	144	16	8 & 8	352	328	172	156
39	4	144	32	8 & 8	352	320	168	152
40	2	144	0	0 & 0	704	704	352	352
41	2	144	4	0 & 0	704	702	350	352
42	2	144	8	0 & 0	704	700	350	350
43	2	144	16	0 & 0	704	696	348	348
44	2	144	32	0 & 0	704	688	344	344
45	2	144	0	2 & 2	704	700	352	348
46	2	144	4	2 & 2	704	698	350	348
47	2	144	8	2 & 2	704	696	350	346
48	2	144	16	2 & 2	704	692	348	344
49	2	144	32	2 & 2	704	684	344	340
50	2	144	0	16 & 16	704	672	352	320
51	2	144	4	16 & 16	704	670	350	320
52	2	144	8	16 & 16	704	668	350	318
53	2	144	16	16 & 16	704	664	348	316
54	2	144	32	16 & 16	704	656	344	312
55	1	144	0	0 & 0	1408	1408	704	704
56	1	144	4	0 & 0	1408	1406	702	704
57	1	144	8	0 & 0	1408	1404	702	702
58	1	144	16	0 & 0	1408	1400	700	700
59	1	144	32	0 & 0	1408	1392	696	696
60	1	144	0	2 & 2	1408	1404	704	700
61	1	144	4	2 & 2	1408	1402	702	700
62	1	144	8	2 & 2	1408	1400	702	698
63	1	144	16	2 & 2	1408	1396	700	696
64	1	144	32	2 & 2	1408	1388	696	692
65	1	144	0	32 & 32	1408	1344	704	640
66	1	144	4	32 & 32	1408	1342	702	640

Advanced Design System 2008

67	1	144	8	32 & 32	1408	1340	702	638
68	1	144	16	32 & 32	1408	1336	700	636
69	1	144	32	32 & 32	1408	1328	696	632

8PSK Modulation Time Slot Formats

Slot Format	Spread Factor	Midamble Length (chips)	NTFCI Code Word (bits)	NSS & NTPC (bits)	Bits/Slot	NData/Slot (bits)	Ndata/Data Field (1) (bits)	Ndata/Data Field (2) (bits)
0	1	144	0	0 & 0	2112	2112	1056	1056
1	1	144	6	0 & 0	2112	2109	1053	1056
2	1	144	12	0 & 0	2112	2106	1053	1053
3	1	144	24	0 & 0	2112	2100	1050	1050
4	1	144	48	0 & 0	2112	2088	1044	1044
5	1	144	0	3 & 3	2112	2106	1056	1050
6	1	144	6	3 & 3	2112	2103	1053	1050
7	1	144	12	3 & 3	2112	2100	1053	1047
8	1	144	24	3 & 3	2112	2094	1050	1044
9	1	144	48	3 & 3	2112	2082	1044	1038
10	1	144	0	48 & 48	2112	2016	1056	960
11	1	144	6	48 & 48	2112	2013	1053	960
12	1	144	12	48 & 48	2112	2010	1053	957
13	1	144	24	48 & 48	2112	2004	1050	954
14	1	144	48	48 & 48	2112	1992	1044	948
15	16	144	0	0 & 0	132	132	66	66
16	16	144	6	0 & 0	132	129	63	66
17	16	144	12	0 & 0	132	126	63	63
18	16	144	24	0 & 0	132	120	60	60
19	16	144	48	0 & 0	132	108	54	54
20	16	144	0	3 & 3	132	126	66	60
21	16	144	6	3 & 3	132	123	63	60
22	16	144	12	3 & 3	132	120	63	57
23	16	144	24	3 & 3	132	114	60	54

24	16	144	48	3 & 3	132	102	54	48
----	----	-----	----	-------	-----	-----	----	----

References

1. 3GPP TS 25.221, 3rd Generation Partnership Project; Technical Specification Group Radio Access Network; Physical channels and mapping of transport channels onto physical channels (TDD) (Release 4), version 4.5.0, Dec., 2001.

TDSCDMA_DPCH_DataMux



Description Multiplexer for data, TFCI, SS and TPC in DPCH

Library TDSCDMA, Modems

Class SDFTDSCDMA_DPCH_DataMux

Parameters

Name	Description	Default	Type	Range
Link	link selection: Downlink, Uplink	Downlink	enum	
SpreadFactor	spreading factor	16	int	{1, 2,4,8,16}
ModType	type of modulation: QPSK, _8PSK	QPSK	enum	
N_TFCI	number of TFCI bits	0	int	
N_SS_N_TPC	number of SS and TPC	0	int	

Values for N_TFCI and N_SS_N_TPC are given in Note 3.

Advanced Design System 2008

Pin Inputs

Pin	Name	Description	Signal Type
1	Data	data of dedicated physical channel	int
2	TFCI	transport format combination indicator bits	int
3	SS	information bits for uplink synchronization control	int
4	TPC	transmit power control bits	int

Pin Outputs

Pin	Name	Description	Signal Type
5	Output	data other than midamble in DPCH	int

Notes/Equations

- This model is used to multiplex data, TFCI bits, SS bits and TPC bits for DPCH. Each firing, Bits/slot Output tokens are produced when N Data/Slot Data tokens, N TFCI TFCI tokens, N SS SS tokens, and N TPC TPC tokens are consumed.
- The burst structure is illustrated in the following figure, where time slot n (n = 0 to 6) are the nth traffic time slots, 864-chip duration; DwPTS is downlink pilot time slot, 96-chip duration; UpPTS is uplink pilot time slot, 160-chip duration; GP is main guard period for TDD operation, 96-chip duration.

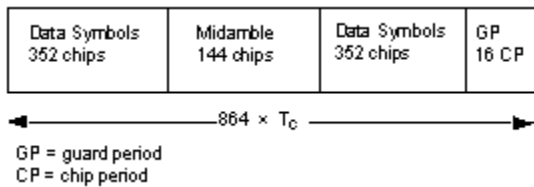

Burst Structure of Traffic Burst Format

- Time slot formats for the downlink with QPSK modulation are given in the first table; time slot formats for uplink with QPSK modulation are given in the second table; time slot formats for both links with 8PSK modulation are given in the third table.

Downlink Time Slot Formats

Slot Format #	Spread Factor	Midamble Length (chips)	NTFCI Code Word (bits)	NSS & NTPC (bits)	Bits/Slot	NData/Slot (bits)	Ndata/Data Field (1) (bits)	Ndata/Data Field (2) (bits)
---------------	---------------	-------------------------	------------------------	-------------------	-----------	-------------------	-----------------------------	-----------------------------

Advanced Design System 2008

0	16	144	0	0 & 0	88	88	44	44
1	16	144	4	0 & 0	88	86	42	44
2	16	144	8	0 & 0	88	84	42	42
3	16	144	16	0 & 0	88	80	40	40
4	16	144	32	0 & 0	88	72	36	36
5	16	144	0	2 & 2	88	84	44	40
6	16	144	4	2 & 2	88	82	42	40
7	16	144	8	2 & 2	88	80	42	38
8	16	144	16	2 & 2	88	76	40	36
9	16	144	32	2 & 2	88	68	36	32
10	1	144	0	0 & 0	1408	1408	704	704
11	1	144	4	0 & 0	1408	1406	702	704
12	1	144	8	0 & 0	1408	1404	702	702
13	1	144	16	0 & 0	1408	1400	700	700
14	1	144	32	0 & 0	1408	1392	696	696
15	1	144	0	2 & 2	1408	1404	704	700
16	1	144	4	2 & 2	1408	1402	702	700
17	1	144	8	2 & 2	1408	1400	702	698
18	1	144	16	2 & 2	1408	1396	700	696
19	1	144	32	2 & 2	1408	1388	696	692
20	1	144	0	32 & 32	1408	1344	704	640
21	1	144	4	32 & 32	1408	1342	702	640
22	1	144	8	32 & 32	1408	1340	702	638
23	1	144	16	32 & 32	1408	1336	700	636
24	1	144	32	32 & 32	1408	1328	696	632

Uplink Time Slot Formats

Slot Format	Spread Factor	Midamble Length (chips)	NTFCI Code Word (bits)	NSS & NTPC (bits)	Bits/Slot	NData/Slot (bits)	Ndata/Data Field (1) (bits)	Ndata/Data Field (2) (bits)
0	16	144	0	0 & 0	88	88	44	44
1	16	144	4	0 & 0	88	86	42	44

Advanced Design System 2008

2	16	144	8	0 & 0	88	84	42	42
3	16	144	16	0 & 0	88	80	40	40
4	16	144	32	0 & 0	88	72	36	36
5	16	144	0	2 & 2	88	84	44	40
6	16	144	4	2 & 2	88	82	42	40
7	16	144	8	2 & 2	88	80	42	38
8	16	144	16	2 & 2	88	76	40	36
9	16	144	32	2 & 2	88	68	36	32
10	8	144	0	0 & 0	176	176	88	88
11	8	144	4	0 & 0	176	174	86	88
12	8	144	8	0 & 0	176	172	86	86
13	8	144	16	0 & 0	176	168	84	84
14	8	144	32	0 & 0	176	160	80	80
15	8	144	0	2 & 2	176	172	88	84
16	8	144	4	2 & 2	176	170	86	84
17	8	144	8	2 & 2	176	168	86	82
18	8	144	16	2 & 2	176	164	84	80
19	8	144	32	2 & 2	176	156	80	76
20	8	144	0	4 & 4	176	168	88	80
21	8	144	4	4 & 4	176	166	86	80
22	8	144	8	4 & 4	176	164	86	78
23	8	144	16	4 & 4	176	160	84	76
24	8	144	32	4 & 4	176	152	80	72
25	4	144	0	0 & 0	352	352	176	176
26	4	144	4	0 & 0	352	350	174	176
27	4	144	8	0 & 0	352	348	174	174
28	4	144	16	0 & 0	352	344	172	172
29	4	144	32	0 & 0	352	336	168	168
30	4	144	0	2 & 2	352	348	176	172
31	4	144	4	2 & 2	352	346	174	172
32	4	144	8	2 & 2	352	344	174	170
33	4	144	16	2 & 2	352	340	172	168

Advanced Design System 2008

34	4	144	32	2 & 2	352	332	168	164
35	4	144	0	8 & 8	352	336	176	160
36	4	144	4	8 & 8	352	334	174	160
37	4	144	8	8 & 8	352	332	174	158
38	4	144	16	8 & 8	352	328	172	156
39	4	144	32	8 & 8	352	320	168	152
40	2	144	0	0 & 0	704	704	352	352
41	2	144	4	0 & 0	704	702	350	352
42	2	144	8	0 & 0	704	700	350	350
43	2	144	16	0 & 0	704	696	348	348
44	2	144	32	0 & 0	704	688	344	344
45	2	144	0	2 & 2	704	700	352	348
46	2	144	4	2 & 2	704	698	350	348
47	2	144	8	2 & 2	704	696	350	346
48	2	144	16	2 & 2	704	692	348	344
49	2	144	32	2 & 2	704	684	344	340
50	2	144	0	16 & 16	704	672	352	320
51	2	144	4	16 & 16	704	670	350	320
52	2	144	8	16 & 16	704	668	350	318
53	2	144	16	16 & 16	704	664	348	316
54	2	144	32	16 & 16	704	656	344	312
55	1	144	0	0 & 0	1408	1408	704	704
56	1	144	4	0 & 0	1408	1406	702	704
57	1	144	8	0 & 0	1408	1404	702	702
58	1	144	16	0 & 0	1408	1400	700	700
59	1	144	32	0 & 0	1408	1392	696	696
60	1	144	0	2 & 2	1408	1404	704	700
61	1	144	4	2 & 2	1408	1402	702	700
62	1	144	8	2 & 2	1408	1400	702	698
63	1	144	16	2 & 2	1408	1396	700	696
64	1	144	32	2 & 2	1408	1388	696	692
65	1	144	0	32 & 32	1408	1344	704	640

Advanced Design System 2008

66	1	144	4	32 & 32	1408	1342	702	640
67	1	144	8	32 & 32	1408	1340	702	638
68	1	144	16	32 & 32	1408	1336	700	636
69	1	144	32	32 & 32	1408	1328	696	632

8PSK Modulation Time Slot Formats

Slot Format	Spread Factor	Midamble Length (chips)	NTFCI Code Word (bits)	NSS & NTPC (bits)	Bits/Slot	NData/Slot (bits)	Ndata/Data Field (1) (bits)	Ndata/Data Field (2) (bits)
0	1	144	0	0 & 0	2112	2112	1056	1056
1	1	144	6	0 & 0	2112	2109	1053	1056
2	1	144	12	0 & 0	2112	2106	1053	1053
3	1	144	24	0 & 0	2112	2100	1050	1050
4	1	144	48	0 & 0	2112	2088	1044	1044
5	1	144	0	3 & 3	2112	2106	1056	1050
6	1	144	6	3 & 3	2112	2103	1053	1050
7	1	144	12	3 & 3	2112	2100	1053	1047
8	1	144	24	3 & 3	2112	2094	1050	1044
9	1	144	48	3 & 3	2112	2082	1044	1038
10	1	144	0	48 & 48	2112	2016	1056	960
11	1	144	6	48 & 48	2112	2013	1053	960
12	1	144	12	48 & 48	2112	2010	1053	957
13	1	144	24	48 & 48	2112	2004	1050	954
14	1	144	48	48 & 48	2112	1992	1044	948
15	16	144	0	0 & 0	132	132	66	66
16	16	144	6	0 & 0	132	129	63	66
17	16	144	12	0 & 0	132	126	63	63
18	16	144	24	0 & 0	132	120	60	60
19	16	144	48	0 & 0	132	108	54	54
20	16	144	0	3 & 3	132	126	66	60
21	16	144	6	3 & 3	132	123	63	60
22	16	144	12	3 & 3	132	120	63	57

23	16	144	24	3 & 3	132	114	60	54
24	16	144	48	3 & 3	132	102	54	48

References

1. 3GPP TS 25.221, 3rd Generation Partnership Project; Technical Specification Group Radio Access Network; Physical channels and mapping of transport channels onto physical channels (TDD) (Release 4), version 4.3.0, Dec., 2001.

TDSCDMA_DPCH_Mux

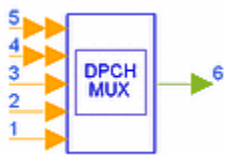

Description DPCH multiplexer
 Library TDSCDMA, Modems
 Class SDFTDSCDMA_DPCH_Mux
 Derived From TDSCDMA_CCTrCH_MuxBase

Parameters

Name	Description	Default	Type	Range
PhyChNum_SA	physical channel allocation configuration	0 0 1 0 0 0 0	int array	[0, 2] for Uplink, [0, 16] for Downlink
Link	link selection: Downlink, Uplink	Uplink	enum	
ModType_SA	type of modulation of all slots, 0 for QPSK, 1 for 8PSK	0 0 0 0 0 0 0	int array	[0, 1] for each element
SpreadCode_PA	index of OVFSF code corresponding to allocated physical channels	1	int array	[1, SpreadFactor]
BasicMidambleID	index of basic	1	int	[0, 127]

Advanced Design System 2008

	midamble			
K_SA	maximum number of midamble shifts in a cell for all slots	16 16 16 16 16 16 16	int array	{2, 4,6,8,10,12,14,16}
MidambleID_SA	index of midamble for all slots	5 5 5 5 5 5	int array	[1, K]
Gain_PA	gain setting array corresponding to allocated physical channels	1.0	real array	(0, ∞)

Pin Inputs

Pin	Name	Description	Signal Type
1	TFCI	encoded TFCI bits input	int
2	SS	information bits for uplink synchronization control	int
3	TPC	transmit power control bits	int
4	DataIn	bits data stream input before mapping, spreading and scrambling	multiple int
5	SlotFormat	slot format input corresponding to each physical channel	multiple int

Pin Outputs

Pin	Name	Description	Signal Type
6	DataOut	output data	complex

Notes/Equations

1. This model generates signals for several dedicated physical channels (DPCH). The number of DPCHs can be determined by the size of multiple input DataIn dynamically in run time. The TDSCDMA_DPCH subnetwork generates a signal for one DPCH (refer to the schematic in [TDSCDMA_DPCH Schematic](#) to see its structure). However, the TDSCDMA_DPCH_Mux model is more flexible and can cover all DPCH combinations from flexible rate matching algorithms in the transport channel. Each firing, 6400 DataOut tokens are produced when 2112 DataIn tokens, 1 SlotFormat token, 48 TFCI, SS and TPC tokens consumed. These are the maximum number of tokens necessary in all cases; the real values needed may be less, padding tokens are filled before this model when needed. Data of all physical channels are fed from the multiple DataIn pin while TFCI bits, SS and TPC bits are fed in

TFCI, SS and TPC pins. The valid size of Data, TFCI, SS and TPC for each DPCH can be calculated from the corresponding input of SlotFormat pin.

2. PhyChNum_SA determines which slots will transmit data and how many physical channels are transferred in one specified slot. It contains 7 elements that represent 7 individual slots. The maximum allocated physical channel number is equal to the sum of the PhyChNum_SA elements. The size of SpreadCode_PA and Gain_PA, the port number of SlotFormat and DataIn must be equal to the sum of the PhyChNum_SA elements.
3. ModType_SA determines the modulation mapping scheme of the data bits: 0 for QPSK, 1 for 8PSK.
4. After modulation, data is spread with corresponding spreading codes. The spreading factors of physical channels are determined by the input of SlotFormat, while the spreading codes index is set by SpreadCode_PA.
5. The index of scramble code is the same as BasicMidambleID.
6. The midamble of each physical channel is determined by UE_Specific based on K_SA and MidambleID_SA settings.
7. Gain_PA determines the gain of each physical channel.

References

1. 3GPP TS 25.221, 3rd Generation Partnership Project; Technical Specification Group Radio Access Network; Physical channels and mapping of transport channels onto physical channels (TDD) (Release 4), version 4.5.0, June 2002.
2. 3GPP TS 25.223, 3rd Generation Partnership Project; Technical Specification Group Radio Access Network; Spreading and modulation (TDD) (Release 4), version 4.5.0, June 2002.

TDSCDMA_Midamble



Description Midamble generation

Library TDSCDMA, Modems

Class SDFTDSCDMA_Midamble

Parameters

Name	Description	Default	Type	Range
MidambleAllocScheme	midamble allocation scheme: UE_Specific, Common, Default	Default	enum	
BasicMidambleID	index of basic	0	int	[0, 127]

Advanced Design System 2008

	midamble			
K	maximum number of midamble shifts in a cell	16	int	{2, 4,6,8,10,12,14,16}
MidambleID	index of midamble	1	int	[1, K]
SpreadFactor	spreading factor	16	int	{1, 2,4,8,16}
SpreadCode	index of spread code	1	int	[1, SpreadFactor]
PhyChNum	number of channelization codes used in a timeslot	1	int	[1, 16]

Pin Outputs

Pin	Name	Description	Signal Type
1	output	midamble output	complex

Notes/Equations

1. This model is used to generate midamble sequence used in TD-SCDMA. Each firing, one token is produced.
2. Midambles of different users active in the same cell and the same time slot are cyclically shifted versions of one basic midamble code. The value of BasicMidambleID determines the index of the basic midamble to be used. The applicable basic midambles are given in Annex B.1 of [1], 128 totally. The basic midamble codes in Annex B.1 are listed in hexadecimal notation. The binary form is derived as given in the following table.

Mapping of 4 Binary Elements m i on a Single Hexadecimal Digit

Binary Elements m i	Hexadecimal Digit Mapping
-1 -1 -1 -1	0
-1 -1 -1 +1	1
-1 -1 +1 -1	2
-1 -1 +1 +1	3
-1 +1 -1 -1	4
-1 +1 -1 +1	5
-1 +1 +1 -1	6
-1 +1 +1 +1	7
+1 -1 -1 -1	8

+1 -1 -1 +1	9
+1 -1 +1 -1	A
+1 -1 +1 +1	B
+1 +1 -1 -1	C
+1 +1 -1 +1	D
+1 +1 +1 -1	E
+1 +1 +1 +1	F

3. For each particular basic midamble code, its binary representation can be written as

$$m_p = (m_1, m_2, \dots, m_p)$$

where $P=128$. As QPSK modulation is used, the midamble is transformed into a complex form

$$\underline{m}_p = (\underline{m}_1, \underline{m}_2, \dots, \underline{m}_p) \cdot \text{The relation between } m_p \text{ and } \underline{m}_p \text{ is given by:}$$

$$\underline{m}_i = (j)^i m_i \text{ where } i = 1, \dots, P$$

Hence, the elements m_i of \underline{m}_p are alternating real and imaginary.

To derive the required midamble, \underline{m} is periodically extended to the size $i_{max} = L_m + (K-1)W$,

where

$L_m = 144$, is the midamble length

$K = 2, 4, 6, 8, 10, 12, 14, 16$, is the maximum number of different midamble shifts in a cell

$W = \left\lfloor \frac{P}{K} \right\rfloor$, is the shift between midambles and $\lfloor x \rfloor$ denotes the largest number less or equal to x .

$P = 128$, is the length of basic midamble.

So a new vector \underline{m} is obtained $\underline{m} = (\underline{m}_1, \underline{m}_2, \dots, \underline{m}_{i_{max}})$

The first P elements of \underline{m} are the same as those in \underline{m}_p , the following elements repeat the beginning:

$$\underline{m}_i = \underline{m}_{i-P} \text{ for the subset } i = (P+1), \dots, i_{i_{max}}$$

The midamble for user k , $\underline{m}^{(k)}$ of length L_m is derived using \underline{m} , which can be written as

$$\underline{m}^{(k)} = (\underline{m}_1^{(k)}, \underline{m}_2^{(k)}, \dots, \underline{m}_{L_m}^{(k)})$$

The L_m midamble elements $\underline{m}_i^{(k)}$ are generated for each midamble of the k users ($k = 1, \dots, K$) based on

$$\underline{m}_i^{(k)} = \underline{m}_{i+(K-k)W} \text{ with } i = 1, \dots, L_m \text{ and } k = 1, \dots, K$$

The derived midambles have complex values and are not subject to channelization or scrambling.

4. There are three midamble allocation schemes.

- UE specific midamble allocation: a UE specific midamble for DL and UL is explicitly assigned by higher layers
- Default midamble allocation: the midamble for DL and UL is assigned by layer 1 depending on associated channelization code.
- Common midamble allocation: the midamble for DL is allocated by layer 1 depending on the number of

channelization codes currently present in the DL time slot.

In the implementation of this model

- if MidambleAllocScheme= UE_Specific, only the BasicMidambleID, K and MidambleID parameters are used to specify which midamble is exported, the values of the other parameters are ignored.
- if MidambleAllocScheme=Common, only the BasicMidambleID, K and PhyChNum parameters are used to specify which midamble is exported, the values of the other parameters are ignored.
- if MidambleAllocScheme=Default, only the BasicMidambleID, K, SpreadFactor and SpreadCode parameters are used to specify which midamble is exported, the values of the other parameters are ignored.

References

1. 3GPP TS 25.221, 3rd Generation Partnership Project; Technical Specification Group Radio Access Network; Physical channels and mapping of transport channels onto physical channels (TDD) (Release 4), version 4.3.0, Dec., 2001.

TDSCDMA_Modulator



Description Modulator to generate QPSK and 8-PSK modulation symbols

Library TDSCDMA, Modems

Class SDFTDSCDMA_Modulator

Parameters

Name	Description	Default	Type
ModType	type of modulation: QPSK, _8PSK	QPSK	enum

Pin Inputs

Pin	Name	Description	Signal Type
1	Input	input data	int

Pin Outputs

Pin	Name	Description	Signal Type
2	Output	output modulation symbols	complex

Notes/Equations

- This model is used to map the bits from the output of the physical channel mapping onto the signal point constellation for QPSK and 8PSK modulation.
Each firing,
 - for QPSK, 1 output token is produced when 2 input tokens are consumed.
 - for 8PSK, 1 output token is produced when 3 input tokens are consumed.
- QPSK data modulation is performed to the bits from the output of the physical channel mapping and combines 2 consecutive binary bits to a complex valued data symbol. Each user burst has two data carrying parts, termed data blocks:

$$\underline{d}^{(k,i)} = \left(\underline{d}_{-1}^{(k,i)}, \underline{d}_{-2}^{(k,i)}, \dots, \underline{d}_{-N_k}^{(k,i)} \right), i = 1, 2; k = 1, \dots, K_{Code}$$

K Code is the number of codes used in a time slot, max K Code =6. N k is the number of symbols per data field for the code k. This number is linked to the spreading factor.

Data symbols $\underline{d}^{(k,i)}$

are generated from two consecutive data bits from the output of the physical channel mapping procedure

$$b_{l,n}^{(k,i)} \in \{0, 1\} l = 1, 2; k = 1, \dots, K_{Code}; n = 1, \dots, N_k; i = 1, 2$$

using the following table.

Symbol Mapping

Input (consecutive binary bit pattern)	Output (complex symbol)
$b_{l,n}^{(k,i)} b_{2,n}^{(k,i)}$	$\underline{d}^{(k,i)}$
00	+j
01	+1
10	-1
11	-j

- 8PSK data modulation is performed to the bits from the output of the physical channel mapping procedure; 3 consecutive binary bits are represented by one complex valued data symbol. Each user burst has two data carrying parts, termed data blocks:

$$\underline{d}^{(k,i)} = \left(\underline{d}_{-1}^{(k,i)}, \underline{d}_{-2}^{(k,i)}, \dots, \underline{d}_{-N_k}^{(k,i)} \right), i = 1, 2; k = 1, \dots, K_{Code}$$

K Code is the number of codes used in a time slot, max K Code =6. N k is the number of symbols per data field for the code k. This number is linked to the spreading factor.

Data symbols $\underline{d}^{(k,i)}$ are generated from 3 consecutive data bits from the output of the physical channel mapping procedure:

$$b_{l,n}^{(k,i)} \in \{0, 1\} \quad l = 1, 2, 3; \quad k = 1, \dots, K_{Code}; \quad n = 1, \dots$$

using the following table.

Symbol Mapping

Input (consecutive binary bit pattern)	Output (complex symbol)
$b_{1,n}^{(k,i)} b_{2,n}^{(k,i)} b_{3,n}^{(k,i)}$	$\underline{d}^{(k,i)}$
000	$\cos(11\pi/8) + j\sin(11\pi/8)$
001	$\cos(9\pi/8) + j\sin(9\pi/8)$
010	$\cos(5\pi/8) + j\sin(5\pi/8)$
011	$\cos(7\pi/8) + j\sin(7\pi/8)$
100	$\cos(13\pi/8) + j\sin(13\pi/8)$
101	$\cos(15\pi/8) + j\sin(15\pi/8)$
110	$\cos(3\pi/8) + j\sin(3\pi/8)$
111	$\cos(\pi/8) + j\sin(\pi/8)$

References

1. 3GPP TS 25.223, 3rd Generation Partnership Project; Technical Specification Group Radio Access Network; Spreading and modulation (TDD) (Release 4), version 4.3.0, Dec., 2001

TDSCDMA_OnePhyCh

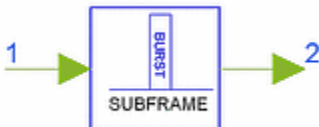

Description One physical channel
Library TDSCDMA, Modems

Class SDFTDSCDMA_OnePhyCh

Parameters

Name	Description	Default	Type	Range
SlotIndex	index of slot	2	int	[0, 6]

Pin Inputs

Pin	Name	Description	Signal Type
1	Burst	burst	complex

Pin Outputs

Pin	Name	Description	Signal Type
2	SubFrm	subframe with only one burst	complex

Notes/Equations

- This model forms one physical channel using a burst.
Each firing, 6400 SubFrm tokens are produced when 864 Burst tokens are consumed.
- To simplify combining of the physical channels, each physical channel is placed at a specific interval in one subframe according to the SlotIndex parameter setting. Special models implement DwPTS and UpPTS.
- The sub-frame structure is illustrated in the following figure. Where Time slot #n (n from 0 to 6) are the nth traffic time slot, 864 chips duration; DwPTS is the downlink pilot time slot, 96 chips duration; UpPTS is the uplink pilot time slot, 160 chips duration; GP is the main guard period for TDD operation, 96 chips duration. The total number of traffic time slots for uplink and downlink is 7, and each traffic time slot is 864 chips duration. Among the 7 traffic time slots, time slot 0 is always allocated as downlink while time slot 1 is always allocated as uplink. Uplink and downlink time slots are separated by switching points. Between downlink and uplink time slots, the special period is the switching point to separate uplink and downlink. In each sub-frame of 5ms for 1.28Mcps option, there are two switching points (uplink to downlink and vice versa).

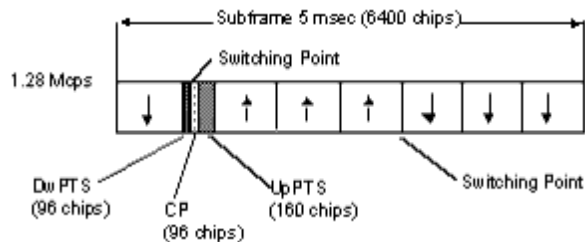

Structure of Subframe for 1.28Mcps TDD Option

References

1. 3GPP TS 25.221, 3rd Generation Partnership Project; Technical Specification Group Radio Access Network; Physical channels and mapping of transport channels onto physical channels (TDD) (Release 4), version 4.3.0, Dec., 2001.

TDSCDMA_OnePhyChDeMux



Description One physical channel demultiplexer
 Library TDSCDMA, Modems
 Class SDFTDSCDMA_OnePhyChDeMux

Parameters

Name	Description	Default	Type	Range
SlotIndex	index of slot	2	int	[0, 6]

Pin Inputs

Pin	Name	Description	Signal Type
1	SubFrm	input subframe	complex

Pin Outputs

Pin	Name	Description	Signal Type
2	slot	output time slot	complex

Notes/Equations

1. This subnetwork is used to demultiplex a specified burst from one physical channel. The schematic for this subnetwork is shown in the following figure. Each firing, 6400 tokens are consumed when 864 tokens produced.

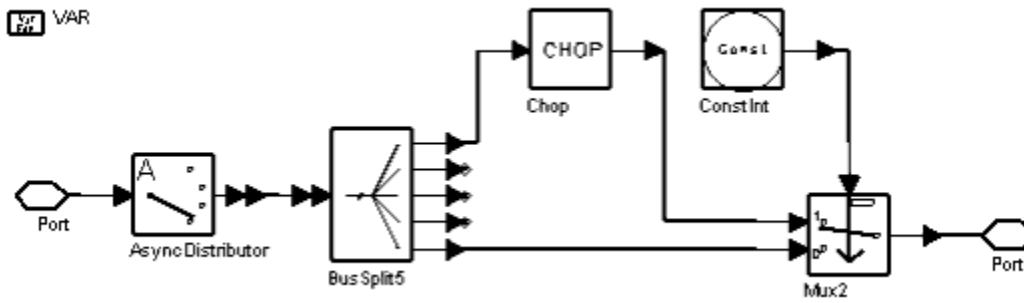

TDSCDMA_OnePhyChDeMux Schematic

- The sub-frame structure is illustrated in the following figure. The slot is chopped and output according to specified slot index.

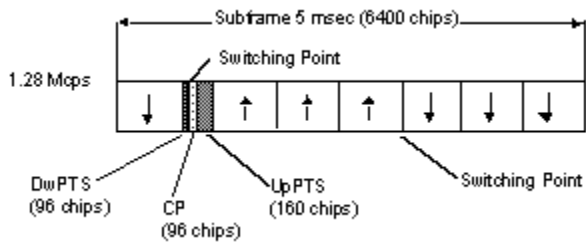

Structure of Subframe for 1.28Mcps TDD Option

References

- 3GPP TS 25.221, 3rd Generation Partnership Project; Technical Specification Group Radio Access Network; Physical channels and mapping of transport channels onto physical channels (TDD) (Release 4), version 4.5.0, Dec., 2001.

TDSCDMA_OVSF



Description OVSF code generation
 Library TDSCDMA, Modems
 Class SDFTDSCDMA_OVSF

Parameters

Name	Description	Default	Type	Range
SpreadFactor	spreading factor	16	int	{1, 2,4,8,16}
SpreadCode	index of OVFSF code	1	int	[1, SpreadFactor]

Pin Outputs

Pin	Name	Description	Signal Type
1	output	OVFSF code output	complex

Notes/Equations

1. This model is used to generate OVFSF codes used in TD-SCDMA. Each firing, one token is produced.
2. The OVFSF codes are derived from the code tree. Each code at each level with length l will generate two codes at the next level with length $2 \times l$. The first l elements of the two son codes are the same as the l elements of the father code, and the last l elements of the son code with lower index are also the same as the l elements of the father code, whereas, the last l elements of the son code with higher index are opposite to the l elements of the father code.

Associated with each OVFSF code is a multiplier

$$w_{Q_k}^{(k)}$$

taking values from the set

$$\left\{ e^{j \frac{\pi}{2^{p_k}}} \right\}$$

where p_k is a permutation of the integer set $\{0, \dots, Q_k - 1\}$ and Q_k the spreading factor.

Values of the multiplier of each channelization code are given in the following table.

The output of this model is the product of the specified OVFSF code and its corresponding multiplier.

Table 4-10. Multiplier of Channelization Code

k	$w_{Q=1}^{(k)}$	$w_{Q=2}^{(k)}$	$w_{Q=4}^{(k)}$	$w_{Q=8}^{(k)}$	$w_{Q=16}^{(k)}$
1	1	1	-j	1	-1
2		+j	1	+j	-j
3			+j	+j	1
4			-1	-1	1
5				-j	+j

6				-1	-1
7				-j	-1
8				1	1
9					-j
10					+j
11					1
12					+j
13					-j
14					-j
15					+j
16					-1

References

1. 3GPP TS 25.223, 3rd Generation Partnership Project; Technical Specification Group Radio Access Network; Spreading and modulation (TDD) (Release 4), version 4.3.0, Dec., 2001

TDSCDMA_PSCH_DataMux



Description Time division multiplexer for physical uplink/downlink data
 Library TDSCDMA, Modems
 Class SDFTDSCDMA_PSCH_DataMux

Parameters

Name	Description	Default	Type	Range
Link	link selection: Downlink, Uplink	Downlink	enum	

Advanced Design System 2008

SpreadFactor	spreading factor	16	int	{1, 16} for downlink; {1,2,4,8,16} for uplink
ModType	type of modulation: QPSK, _8PSK	QPSK	enum	
N_TFCI	number of TFCI bits	0	int	{0, 4,8,16,32} for QPSK; {0,6,12,24,48} for 8PSK

Pin Inputs

Pin	Name	Description	Signal Type
1	Data	data of dedicated physical channel	int
2	TFCI	transport format combination indicator bits	int

Pin Outputs

Pin	Name	Description	Signal Type
3	Output	data other than midamble in PSCH	int

Notes/Equations

1. This model is used to multiplex data, TFCI bits for PD/USCH.

Each firing,

- for QPSK, $1408/\text{SpreadFactor}$ Output tokens are produced when $(1408/\text{SpreadFactor}-N_TFCI/2)$ Data tokens and $N_TFCI/2$ TFCI tokens are consumed.
- for 8PSK, $2112/\text{SpreadFactor}$ Output tokens are produced when $(2112/\text{SpreadFactor}-N_TFCI/2)$ Data tokens and $N_TFCI/2$ TFCI tokens are consumed.

Physical downlink/uplink shared channel provides TFCI transmission.

References

1. 3GPP TS 25.221, 3rd Generation Partnership Project; Technical Specification Group Radio Access Network; Physical channels and mapping of transport channels onto physical channels (TDD) (Release 4), version 4.3.0, Dec., 2001

TDSCDMA_Scramble



Description Scramble generation
 Library TDSCDMA, Modems
 Class SDFTDSCDMA_Scramble

Parameters

Name	Description	Default	Type	Range
ScrambleCode	index of scramble code	0	int	[0, 127]

Pin Outputs

Pin	Name	Description	Signal Type
1	output	scramble code output	complex

Notes/Equations

1. This model is used to generate the scramble code used in TD-SCDMA. Each firing, one token is produced.
2. Spreading of data consists of channelization and scrambling operations. Each complex valued data symbol is spread with a real channelization code of length $Q_k \in \{1, 2, 4, 8, 16\}$. The resulting sequence is then scrambled by a cell specific complex scrambling sequence \underline{v} of length 16, where

$$\underline{v} = (v_1, v_2, \dots, v_{16})$$

The complex scrambling code \underline{v} is generated from the binary scrambling code

$$\underline{v} = (v_1, v_2, \dots, v_{16})$$

The available binary scrambling codes are given in Annex A of [1], 128 totally. The relation between the elements of \underline{v} and \underline{v} is given by:

$$\underline{v} = (j)^i v_i$$

where $v_i \in \{1, -1\}$, $i=1, \dots, 16$

Hence, the elements \underline{v}_i of \underline{v} are alternating real and imaginary.

References

1. 3GPP TS 25.223, 3rd Generation Partnership Project; Technical Specification Group Radio Access Network; Spreading and modulation (TDD) (Release 4), version 4.3.0, Dec., 2001.

TDSCDMA_Sync



Description Synchronization code generation
 Library TDSCDMA, Modems
 Class SDFTDSCDMA_Sync

Parameters

Name	Description	Default	Type	Range
LinkDir	link direction: Down, Up	Down	enum	
SyncCode	index of basic synchronization code	0	int	[0, 31] when LinkDir=Down; [0, 255] when LinkDir=Up

ModPhase	type of modulation quadruples, valid only in downlink: S1, S2	S1	enum	
----------	---	----	------	--

Pin Outputs

Pin	Name	Description	Signal Type
1	output	sync code output	complex

Notes/Equations

- This model generates the SYNC_DL and SYNC_UL sequences. Each firing, one token is produced.
- DwPTS is composed of 64 chips of a complex SYNC_DL sequence $\underline{s} = (s_1, s_2, \dots, s_{64})$ and 32 chips of guard period. SYNC_DL code is not scrambled. To generate the complex SYNC_DL code, the basic SYNC_DL code $\underline{s} = (s_1, s_2, \dots, s_{64})$ is used. There are 32 different basic SYNC_DL codes for the whole system. The relation between \underline{s} and \underline{s} is given by:

$$s_i = (j)^i v_i s_i \text{ where } v_i \in \{1, -1\}, i = 1, \dots, 64$$

Hence, the elements s_i of \underline{s} are alternating real and imaginary.

- The SYNC_DL is QPSK modulated; the SYNC_DL phase is used to signal the presence of the P-CCPCH in the multi-frame of the resource units of the first two code channels in time slot 0. The SYNC_DL sequences are modulated with respect to the midamble (m (1)) in time slot 0. Four consecutive phases (phase quadruple) of the SYNC_DL are used to indicate the presence of the P-CCPCH in the following 4 sub-frames. When the presence of a P-CCPCH is indicated, the following sub-frame is the first subframe of the interleaving period. As QPSK is used for the modulation of the SYNC-DL, the phase 45, 135, 225 and 315 are used. The total number of different phase quadruples is 2 (S1 and S2). A quadruple always starts with an even system frame number ((SFN mod 2)=0). The following table describes the quadruples.

Phase Modulation Sequences for SYNC-DL

Name	Phase Quadruple	Description
S1	135,45,225,135	There is a P-CCPCH in the next 4 sub-frames
S2	315,225,315,45	There is no P-CCPCH in the next 4 sub-frames

In the implementation of this model,

- if LinkDir=Down and ModPhase=S1, SYNC_DL sequences $\underline{s} = (s_1, s_2, \dots, s_{64})$ in every 4 subframes

are rotated additionally with angles of 135, 45, 225, and 135 degrees.

- if LinkDir=Down and ModPhase=S2, SYNC_DL sequences $\underline{s} = (s_{-1}, s_{-2}, \dots, s_{-64})$ in every 4 subframes

are rotated additionally with angles of 315, 225, 315, and 45 degrees.

- If LinkDir=Up, the model ignores the value of ModPhase and the SYNC_DL sequence \underline{s} does not have additional rotation.

4. UpPTS is composed of 128 chips of a complex SYNC_UL sequence $\underline{s} = (s_{-1}, s_{-2}, \dots, s_{-128})$ and 32 chips of

guard period.

The SYNC_UL code is not scrambled.

For UL code, the basic SYNC_DL code $\underline{s} = (s_{-1}, s_{-2}, \dots, s_{-128})$ is used.

There are 256 different basic SYNC_UL codes for the whole system. The relation between \underline{s} and s is given by:

$$s_{-i} = (j)^i s_i \text{ where } v_i \in \{1, -1\}, i = 1, \dots, 128$$

Hence, the elements s_{-i} of \underline{s} are alternating real and imaginary.

References

1. 3GPP TS 25.223, 3rd Generation Partnership Project; Technical Specification Group Radio Access Network; Spreading and modulation (Release 4), version 4.3.0, Dec., 2001.

Multiplexing and Coding Components

TDSCDMA_1stDeIntlvr



Description First deinterleaver

Library TDSCDMA, Multiplexing & Coding

Advanced Design System 2008

Class SDFTDSCDMA_1stDeIntlvr
 Derived From TDSCDMA_ChDecodingBase

Parameters

Name	Description	Default	Type	Range
DynTF_Set	dynamic part of Transport Format Set	244 488	int array	†
TTI	transmission time interval: TTI_10ms, TTI_20ms, TTI_40ms, TTI_80ms	TTI_10ms	enum	
CRC	length of CRC bits: No_CRC, CRC_8_bits, CRC_12_bits, CRC_16_bits, CRC_24_bits	CRC_16_bits	enum	
ChCodingType	channel coding type: No_Coding, CC_HalfRate, CC_OneThirdRate, TurboCoding	CC_HalfRate	enum	

† The array structure of DynTF_Set is [transport block size 1, transport block set size 1, transport block size 2, transport block set size 2, ...] The value range of transport block size is [0, 5000]. The value range of transport block set size is [0, 20000]. Transport block set size must be an integer multiple of transport block size.

Pin Inputs

Pin	Name	Description	Signal Type
1	DataI	input data	real
2	TFI_I	transport format indicator	int

Pin Outputs

Pin	Name	Description	Signal Type
3	DataO	output data	real
4	TFI_O	transport format indicator	int

Notes/Equations

1. This model implements reverse process of first interleaver.
2. Each firing, 1 TFI_O token and N DataO tokens are produced when 1 TFI_I and N DataI tokens consumed, while N is calculated using the maximum value of transport block set size, that is, the maximum valid data in one TTI.
3. TFI value is an index used to select the transport block size and transport block set size from the transport format set, as specified by DynTF_Set. The minimal TFI is 0, the step is 1. The number of input and output tokens in each firing is calculated using the maximum value of transport block set size, while the valid tokens is calculated using the transport block set indexed by TFI.
4. The first interleaving is a block interleaver with inter-column permutations. This model recover the order of data in one TTI.

References

1. 3GPP Technical Specification TS 25.222 V4.4.0, Multiplexing and channel coding (TDD) Release 4.

TDSCDMA_1stIntlvr



Description First interleaver
 Library TDSCDMA, Multiplexing & Coding
 Class SDFTDSCDMA_1stIntlvr
 Derived From TDSCDMA_ChEncodingBase

Parameters

Name	Description	Default	Type	Range
DynTF_Set	dynamic part of Transport Format Set	244 488	int array	+
TTI	transmission time interval: TTI_10ms, TTI_20ms, TTI_40ms, TTI_80ms	TTI_10ms	enum	

Advanced Design System 2008

CRC	length of CRC bits: No_CRC, CRC_8_bits, CRC_12_bits, CRC_16_bits, CRC_24_bits	CRC_16_bits	enum	
ChCodingType	channel coding type: No_Coding, CC_HalfRate, CC_OneThirdRate, TurboCoding	CC_HalfRate	enum	

† The array structure of DynTF_Set is [transport block size 1, transport block set size 1, transport block+size 2, transport block set size 2, ...] The value range of transport block size is [0, 5000]. The value range of transport block set size is [0, 20000]. Transport block set size must be an integer multiple of transport block size.

Pin Inputs

Pin	Name	Description	Signal Type
1	DataI	transport block set	int
2	TFI_I	transport format indicator	int

Pin Outputs

Pin	Name	Description	Signal Type
3	DataO	transport block set with CRC attached	int
4	TFI_O	transport format indicator	int

Notes/Equations

1. This model implements block interleaving.
2. Each firing, 1 TFI_O token and N DataO tokens are produced when 1 TFI_I and N DataI tokens consumed, while N is calculated using the maximum value of transport block set size, that is, the maximum valid data in one TTI.
3. TFI value is an index used to select the transport block size and transport block set size from the transport format set, as specified by DynTF_Set. The minimal TFI is 0, the step is 1. The number of input and output tokens in each firing is calculated using the maximum value of transport block set size, while the valid tokens is calculated using the transport block set indexed by TFI.
4. The first interleaving is a block interleaver with inter-column permutations.

References

1. 3GPP Technical Specification TS 25.222 V4.4.0, Multiplexing and channel coding (TDD) Release 4.

TDSCDMA_2ndDeIntlvr



Description Second deinterleaver
 Library TDSCDMA, Multiplexing & Coding
 Class SDFTDSCDMA_2ndDeIntlvr
 Derived From TDSCDMA_CCTrCH_Base

Parameters

Name	Description	Default	Type	Range
PhyChNum_SA	physical channel allocation configuration	0 0 1 0 0 0 0	int array	[0, 2] for Uplink, [0, 16] for Downlink
IntlvrMethod	interleaving method for the second interleaver: Frame, Slot	Slot	enum	

Pin Inputs

Pin	Name	Description	Signal Type
1	DataIn	input data	multiple real
2	SizeInM	input data length	multiple int

Pin Outputs

Pin	Name	Description	Signal Type
3	DataOut	output data	multiple real
4	SizeOutM	output data length	multiple int

Notes/Equations

1. This model performs the inverse operation of the second interleaving. Each firing, this model consumes $704 \times 3 \times 2$ interleaved tokens for each physical channel on multiple pin DataIn, which is the maximum number of data bits one physical channel can contain in one frame. The tokens consist of valid ones and padding ones. 1 token for each physical channel is consumed on multiple pin SizeInM to indicate the number of valid tokens on DataIn. $704 \times 3 \times 2$ deinterleaved tokens are exported for each physical channel on multiple pin DataOut, which also consists of valid ones and padding ones. 1 token for each physical channel is consumed on multiple pin SizeOutM to indicate the number of valid tokens on DataOut.
2. PhyChNum_SA indicates the number of physical channels allocated in each time slot.
3. Second interleaving can be applied jointly to all data bits transmitted during one frame, or separately within each time slot, on which the CCTrCH is mapped. IntlvrMethod indicates which method is used.
4. For details regarding second interleaving, refer to [1].

References

1. 3GPP Technical Specification TS 25.222 V4.4.0, Multiplexing and channel coding (TDD) Release 4.

TDSCDMA_2ndIntlvr



Description Second interleaver
 Library TDSCDMA, Multiplexing & Coding
 Class SDFTDSCDMA_2ndIntlvr
 Derived From TDSCDMA_CCTrCH_Base

Parameters

Name	Description	Default	Type	Range
PhyChNum_SA	physical channel allocation configuration	0 0 1 0 0 0 0	int array	[0, 2] for Uplink, [0, 16] for Downlink
IntlvrMethod	interleaving method for the second interleaver: Frame,	Slot	enum	

Advanced Design System 2008

	Slot			
--	------	--	--	--

Pin Inputs

Pin	Name	Description	Signal Type
1	DataIn	input data	multiple int
2	SizeInM	input data length	multiple int

Pin Outputs

Pin	Name	Description	Signal Type
3	DataOut	output data	multiple int
4	SizeOutM	output data length	multiple int

Notes/Equations

1. This model performs second interleaving, which acts as a block interleaver and consists of bits input to a matrix with padding, the inter-column permutation for the matrix and bits output from the matrix with pruning. Each firing, this model consumes $704 \times 3 \times 2$ tokens for each physical channel on multiple pin DataIn, which is the maximum number of data bits one physical channel can contain in one frame. The tokens consist of valid ones and padding ones. 1 token for each physical channel is consumed on multiple pin SizeInM to indicate the number of valid tokens on DataIn. $704 \times 3 \times 2$ interleaved tokens are exported for each physical channel on multiple pin DataOut, which also consists of valid ones and padding ones. 1 token for each physical channel is consumed on multiple pin SizeOutM to indicate the number of valid tokens on DataOut.
2. PhyChNum_SA indicates the number of physical channels allocated in each time slot.
3. Second interleaving can be applied jointly to all data bits transmitted during one frame, or separately within each time slot, on which the CCTrCH is mapped. IntlvrMethod indicates which method is used.
4. For details regarding second interleaving, refer to [1].

References

1. 3GPP Technical Specification TS 25.222 V4.4.0, Multiplexing and channel coding (TDD) Release 4 .

TDSCDMA_BitScrambling



Description Bit scrambling
 Library TDSCDMA, Multiplexing & Coding
 Class SDFTDSCDMA_BitScrambling

Parameters

Name	Description	Default	Type	Range
PhyChNum_SA	physical channel allocation configuration	0 0 1 0 0 0 0	int array	[0, 16]

Pin Inputs

Pin	Name	Description	Signal Type
1	DataIn	input data	int

Pin Outputs

Pin	Name	Description	Signal Type
2	DataOut	output data	int

Notes/Equations

1. This model implements bit scrambling.
2. Each firing, $\text{PhyChNumAll} \times \text{MAX_BIT_SLOT}$ tokens are consumed at DataIn, and $\text{PhyChNumAll} \times \text{MAX_BIT_SLOT}$ tokens are exported at DataOut. PhyChNumAll is the number of allocated physical channels and MAX_BIT_SLOT is the maximum number of bits possible in one physical channel, that is $704 \times 3 \times 2$.
3. The bits output from the transport channel multiplexer are scrambled by bit scrambler. The input bits to the bit scrambler are denoted by $h_1, h_2, h_3, \dots, h_s$, where S is the number of bits input to the bit scrambling block equal to the total number of bits on the CCTrCH. The bits after bit scrambling are denoted by $s_1, s_2, s_3, \dots, s_s$. Bit scrambling is defined by the following action:

$$S_k = h_k \oplus p_k$$

where $k=1, 2, \dots, S$ and p_k results from the following operation:

$$p_k = \left(\sum_{i=1}^{16} g_i \times p_{k-i} \right) \text{mod} 2; p_k = 0; (k < 1); p_1 = 1; g = \{0, 0, 0, 0, 0, 0, 0, 0, 0, 0, 1, 0, 1, 1, 0, 1\}$$

References

1. 3GPP Technical Specification TS 25.222 V4.4.0, Multiplexing and channel coding (TDD) Release 4.

TDSCDMA_ChCoding



Description Channel coding
 Library TDSCDMA, Multiplexing & Coding
 Class SDFTDSCDMA_ChCoding
 Derived From TDSCDMA_ChEncodingBase

Parameters

Name	Description	Default	Type	Range
DynTF_Set	dynamic part of Transport Format Set	244 488	int array	†
CRC	length of CRC bits: No_CRC, CRC_8_bits, CRC_12_bits, CRC_16_bits, CRC_24_bits	CRC_16_bits	enum	
ChCodingType	channel coding type: No_Coding, CC_HalfRate, CC_OneThirdRate, TurboCoding	CC_HalfRate	enum	

† The array structure of DynTF_Set is [transport block size 1, transport block set size 1, transport block size 2, transport block set size 2, ...] The value range of transport block size is [0, 5000]. The value range of transport block set size is [0, 20000]. Transport block set size must be an integer multiple of transport block size.

Pin Inputs

Pin	Name	Description	Signal Type
1	DataI	transport block set	int
2	TFI_I	transport format indicator	int

Pin Outputs

Pin	Name	Description	Signal Type
3	DataO	transport block set with CRC attached	int
4	TFI_O	transport format indicator	int

Notes/Equations

1. This model implements channel coding.
2. Each firing, 1 TFI_O token and N DataO tokens are produced when 1 TFI_I and M DataI tokens consumed, while N and M are calculated using the maximum value of transport block set size, that is, the maximum valid data in one TTI after and before channel coding.
TFI value is an index used to select the transport block size and transport block set size from the transport format set, as specified by DynTF_Set. The minimal TFI is 0, the step is 1. The number of input and output tokens in each firing is calculated using the maximum value of transport block set size, while the valid tokens is calculated using the transport block set indexed by TFI.
3. The following channel coding schemes can be applied to transport channels:
 - convolutional coding
 - turbo coding
 - no coding

Usage of coding scheme and coding rate for the different types of TrCH is given in the following table. The values of Y_i in connection with each coding scheme:

 - convolutional coding with rate 1/2: $Y_i = 2 \times K_i + 16$; rate 1/3: $Y_i = 3 \times K_i + 24$;
 - turbo coding with rate 1/3: $Y_i = 3 \times K_i + 12$;
 - no coding: $Y_i = K_i$.

where Y_i is the number of encoded bits, and K_i is the number of bits in each code block.

Channel Coding Schemes and Rates for 1.28 Mcps TDD

Type of TrCH	Coding Scheme	Coding Rate
BCH	Convolutional coding	1/3
PCH		1/3, 1/2
RACH		1/2
DCH, DSCH, FACH, USCH		1/3, 1/2
	Turbo coding	1/3
	No coding	

- Convolutional codes with constraint length 9 and coding rates 1/3 ($G_0 = 557$ (octal), $G_1 = 663$ (octal), $G_2 = 711$ (octal)) and 1/2 ($G_0 = 561$ (octal), $G_1 = 753$ (octal)) are defined.
- The scheme of Turbo coder is a parallel concatenated convolutional code (PCCC) with two 8-state constituent encoders and one Turbo code internal interleaver. The coding rate of Turbo coder is 1/3.
The transfer function of the 8-state constituent code for PCCC is:

$$G(D) = [1, g_1(D)/g_0(D)]$$

where

$$g_0(D) = 1 + D^2 + D^3$$

$$g_1(D) = 1 + D + D^3$$

Trellis termination is performed by taking the tail bits from the shift register feedback after all information bits are encoded. Tail bits are padded after the encoding of information bits.

References

- 3GPP Technical Specification TS 25.222 V4.4.0, Multiplexing and channel coding (TDD) Release 4.

TDSCDMA_ChDecoding



Description Channel decoding
 Library TDSCDMA, Multiplexing & Coding
 Class SDFTDSCDMA_ChDecoding
 Derived From TDSCDMA_ChCodingBase

Parameters

Name	Description	Default	Type	Range
DynTF_Set	dynamic part of Transport Format Set	244 488	int array	†
CRC	length of CRC bits: No_CRC, CRC_8_bits, CRC_12_bits, CRC_16_bits, CRC_24_bits	CRC_16_bits	enum	
ChCodingType	channel coding type: No_Coding, CC_HalfRate, CC_OneThirdRate, TurboCoding	CC_HalfRate	enum	
TC_Iterative	times of iterative decoding in turbo decoder	4	int	[1, 10]

† The array structure of DynTF_Set is [transport block size 1, transport block set size 1, transport block size 2, transport block set size 2, ...] The value range of transport block size is [0, 5000]. The value range of transport block set size is [0, 20000]. Transport block set size must be an integer multiple of transport block size.

Pin Inputs

Pin	Name	Description	Signal Type
1	DataI	input data	real
2	TFI_I	transport format indicator	int

Pin Outputs

Pin	Name	Description	Signal Type
3	DataO	output data	int
4	TFI_O	transport format indicator	int

Notes/Equations

- This model implements channel decoding.
- Each firing, 1 TFI_O token and N DataO tokens are produced when 1 TFI_I and M DataI tokens are consumed, while M and N are calculated using the maximum value of transport block set size ; that is, the maximum valid data in one TTI before and after channel coding.
TFI value is an index used to select the transport block size and transport block set size from the transport format set, as specified by DynTF_Set. The minimal TFI is 0, the step is 1. The number of input and output tokens in each firing is calculated using the maximum value of transport block set size, while the valid tokens is calculated using the transport block set indexed by TFI.
- These channel coding schemes can be applied to transport channels:
 - convolutional coding;
 - turbo coding;
 - no coding.

Usage of coding scheme and coding rate for the different types of TrCH is given in the following table. The values of Y_i in connection with each coding scheme:

 - convolutional coding with rate 1/2: $Y_i = 2 \times K_i + 16$; rate 1/3: $Y_i = 3 \times K_i + 24$;
 - turbo coding with rate 1/3: $Y_i = 3 \times K_i + 12$;
 - no coding: $Y_i = K_i$.

where Y_i is the number of encoded bits, and K_i is the number of bits in each code block.

Channel Coding Schemes and Rates for 1.28Mcps TDD

Type of TrCH	Coding Scheme	Coding Rate
BCH	Convolutional coding	1/3
PCH		1/3, 1/2
RACH		1/2
DCH, DSCH, FACH, USCH		1/3, 1/2
	Turbo coding	1/3
	No coding	

- Convolutional codes with constraint length 9 and coding rates 1/3 ($G_0 = 557$ (octal), $G_1 = 663$ (octal), $G_2 = 711$ (octal)) and 1/2 ($G_0 = 561$ (octal), $G_1 = 753$ (octal)) are defined.
- This model uses Viterbi algorithm to decode convolutional code.
- The scheme of turbo coder is a parallel concatenated convolutional code (PCCC) with two 8-state constituent encoders and one Turbo code internal interleaver. The coding rate of turbo coder is 1/3.
The transfer function of the 8-state constituent code for PCCC is:

$$G(D)=[1, g_1(D)/g_0(D)],$$

where

$$g_0(D) = 1 + D^2 + D^3,$$
$$g_1(D) = 1 + D + D^3.$$

Trellis termination is performed by taking the tail bits from the shift register feedback after all information bits are encoded. Tail bits are padded after the encoding of information bits.

7. This model performs turbo code decoding with MAP algorithm (Maximum A Posterior). It is a modified BCJR algorithm for RSC code. Two parallel concatenated MAP decoders constitute the turbo code decoder.

References

1. 3GPP Technical Specification TS 25.222 V4.4.0, Multiplexing and channel coding (TDD) Release 4.
2. S. Lin and D. J. Costello, Jr., *Error Control Coding Fundamentals and Applications*, Prentice Hall, Englewood Cliffs NJ, 1983.
3. L.R. Bahl, J. Cocke, F. Jeinek and J. Raviv. "Optimal decoding of linear codes for minimizing symbol error rate," *IEEE Trans. Inform. Theory*, vol. IT-20. pp.248-287, Mar. 1974.
4. C. Berrou, A. Glavieux, and P. Thitimjshima, "Near Shannon limit error correcting coding: Turbo codes," *IEEE International Conference on Communications*, pp. 1064-1070, May 1993.

TDSCDMA_CodeBlkSeg



Description Code block segmentation
Library TDSCDMA, Multiplexing & Coding
Class SDFTDSCDMA_CodeBlkSeg
Derived From TDSCDMA_ChEncodingBase

Parameters

Advanced Design System 2008

Name	Description	Default	Type	Range
DynTF_Set	dynamic part of Transport Format Set	244 488	int array	†
CRC	length of CRC bits: No_CRC, CRC_8_bits, CRC_12_bits, CRC_16_bits, CRC_24_bits	CRC_16_bits	enum	
ChCodingType	channel coding type: No_Coding, CC_HalfRate, CC_OneThirdRate, TurboCoding	CC_HalfRate	enum	

Pin Inputs

Pin	Name	Description	Signal Type
1	DataI	transport block set	int
2	TFI_I	transport format indicator	int

Pin Outputs

Pin	Name	Description	Signal Type
3	DataO	transport block set with CRC attached	int
4	TFI_O	transport format indicator	int

Notes/Equations

1. This model implements transport block concatenation and code block segmentation.
2. Each firing, 1 TFI_I token and N DataO tokens are produced when 1 TFI_I and M DataI tokens consumed, while N and M is calculated using the maximum value of transport block set size ; that is, the maximum valid data in one TTI after and before adding possible filler bits.
3. TFI value is an index used to select the transport block size and transport block set size from the transport format set, as specified by DynTF_Set. The minimal TFI is 0, the step is 1. The number of input and output tokens in each firing is calculated using the maximum value of transport block set size, while the valid tokens is calculated using the transport block set indexed by TFI.
4. All transport blocks in a TTI are serially concatenated. If the number of bits in a TTI is larger than the maximum size of a code block, then code block segmentation is performed after the concatenation of the transport blocks. The maximum size of the code blocks depends on whether convolutional, turbo coding or no coding is used for the TrCH.
Segmentation of the bit sequence from transport block concatenation is performed if $X_i > Z$. The code blocks

after segmentation are of the same size. The number of code blocks on TrCH i is denoted by C_i . If the number of bits input to the segmentation, X_i , is not a multiple of C_i , filler bits are added to the beginning of the first block. If turbo coding is selected and $X_i < 40$, filler bits are added to the beginning of the code block. The filler bits are transmitted and they are always set to 0. The maximum code block sizes are:

- convolutional coding: $Z = 504$;
- turbo coding: $Z = 5114$;
- no channel coding: $Z = \text{unlimited}$.

References

1. 3GPP Technical Specification TS 25.222 V4.4.0, Multiplexing and channel coding (TDD) Release 4.

TDSCDMA_CRC_Decoder



Description CRC decoder for transport block
 Library TDSCDMA, Multiplexing & Coding
 Class SDFTDSCDMA_CRC_Decoder
 Derived From TDSCDMA_ChCodingBase

Parameters

Name	Description	Default	Type	Range
DynTF_Set	dynamic part of Transport Format Set	244 488	int array	†
CRC	length of CRC bits: No_CRC, CRC_8_bits, CRC_12_bits, CRC_16_bits, CRC_24_bits	CRC_16_bits	enum	

† The array structure of DynTF_Set is [transport block size 1, transport block set+size 1, transport block size 2,

transport block set size 2, ...] The value range of transport block size is [0, 5000]. The value range of transport block set size is [0, 20000]. Transport block set size must be an integer multiple of transport block size.

Pin Inputs

Pin	Name	Description	Signal Type
1	DataI	transport block set	int
2	TFI_I	transport format indicator	int

Pin Outputs

Pin	Name	Description	Signal Type
3	DataO	transport block set with CRC attached	int
4	error	packet error indicator	int

Notes/Equations

1. This model adds CRC bits to each transport block.
2. Each firing, 1 error token and N DataO tokens are produced when 1 TFI_I and (N+CRC × m) DataI tokens consumed, while N is the maximum value of transport block set size, m is N divided by corresponding transport block size and CRC is the length of CRC bits.
3. TFI value is an index used to select the transport block size and transport block set size from the transport format set, as specified by DynTF_Set. The minimal TFI is 0, the step is 1. The number of input and output tokens in each firing is calculated using the maximum value of transport block set size, while the valid tokens is calculated using the transport block set indexed by TFI.
4. CRC bits are attached to each transport block.
The entire transport block is used to calculate the CRC parity bits for each transport block. The parity bits are generated by one of the following cyclic generator polynomials:

$$g_{CRC24}(D) = D^{24} + D^{23} + D^6 + D^5 + D + 1$$

$$g_{CRC16}(D) = D^{16} + D^{12} + D^5 + 1$$

$$g_{CRC12}(D) = D^{12} + D^{11} + D^3 + D^2 + D + 1$$

$$g_{CRC8}(D) = D^8 + D^7 + D^4 + D^3 + D + 1$$

If transport blocks are not input to the CRC calculation ($M_i = 0$), a CRC will not be attached; if transport blocks are input to the CRC calculation ($M_i \neq 0$) and the size of a transport block is zero ($A_i = 0$), a CRC will be attached (all parity bits equal to zero).

The bits after the CRC attachment are denoted by $b_{im1}, b_{im2}, b_{im3}, \dots, b_{imB_i}$, where $B_i = A_i + L_i$. The relation between aim_k and bim_k is:

$b_{imk} = a_{imk}$
 $k = 1, 2, 3, \dots, A_i$
 $b_{imk} = p_{im(L+1-(K-A))}$,
 $k = A_i + 1, A_i + 2, A_i + 3, \dots, A_i + L_i$

- The model regenerates the CRC bits and compares with the received CRC bits for each transport block. If any are different, the transport block will be marked as a wrong block. The number of wrong blocks of each firing is the output of error.

References

- 3GPP Technical Specification TS 25.222 V4.4.0, Multiplexing and channel coding (TDD) Release 4.

TDSCDMA_CRC_Encoder



Description CRC generator for transport block
 Library TDSCDMA, Multiplexing & Coding
 Class SDFTDSCDMA_CRC_Encoder
 Derived From TDSCDMA_ChEncodingBase

Parameters

Name	Description	Default	Type	Range
DynTF_Set	dynamic part of Transport Format Set	244 488	int array	†
CRC	length of CRC bits: No_CRC, CRC_8_bits, CRC_12_bits, CRC_16_bits,	CRC_16_bits	enum	

	CRC_24_bits			
† The array structure of DynTF_Set is [transport block size 1, transport block set size 1, transport block size 2, transport block set size 2, ...] The value range of transport block size is [0, 5000]. The value range of transport block set size is [0, 20000]. Transport block set size must be an integer multiple of transport block size.				

Pin Inputs

Pin	Name	Description	Signal Type
1	DataI	transport block set	int
2	TFI_I	transport format indicator	int

Pin Outputs

Pin	Name	Description	Signal Type
3	DataO	transport block set with CRC attached	int
4	TFI_O	transport format indicator	int

Notes/Equations

1. This model adds CRC bits to each transport block.
2. Each firing, 1 TFI_O token and (N+CRC × m) DataO tokens are produced when 1 TFI_I and N DataI tokens consumed, while N is the maximum value of transport block set size, m is N divided by corresponding transport block size and CRC is the length of CRC bits.
3. TFI value is an index used to select the transport block size and transport block set size from the transport format set, as specified by DynTF_Set. The minimal TFI is 0, the step is 1. The number of input and output tokens in each firing is calculated using the maximum value of transport block set size, while the valid tokens is calculated using the transport block set indexed by TFI.
4. CRC bits are attached to each transport block.
The entire transport block is used to calculate the CRC parity bits for each transport block. The parity bits are generated by one of the following cyclic generator polynomials:

$$g \text{ CRC24}(D) = D^{24} + D^{23} + D^6 + D^5 + D + 1$$

$$g \text{ CRC16}(D) = D^{16} + D^{12} + D^5 + 1$$

$$g \text{ CRC12}(D) = D^{12} + D^{11} + D^3 + D^2 + D + 1$$

$$g \text{ CRC8}(D) = D^8 + D^7 + D^4 + D^3 + D + 1$$

If no transport blocks are input to the CRC calculation ($M_i = 0$), no CRC attachment will be done. If transport blocks are input to the CRC calculation ($M_i \neq 0$) and the size of a transport block is zero ($A_i = 0$), CRC must be attached, i.e. all parity bits equal to zero.

The bits after CRC attachment are denoted by b_{im1} , b_{im2} , $b_{im3}, \dots, b_{imB_i}$, where $B_i = A_i + L_i$. The relation

between a_{imk} and b_{imk} is:

$$b_{imk} = a_{imk}$$

$$k = 1, 2, 3, \dots, A_i$$

$$b_{imk} = p_{im}(L+1-(K-A)),$$

$$k = A_i + 1, A_i + 2, A_i + 3, \dots, A_i + L_i$$

References

1. 3GPP Technical Specification TS 25.222 V4.4.0, Multiplexing and channel coding (TDD) Release 4.

TDSCDMA_DeCodeBlkSeg



Description Code block desegmentation
 Library TDSCDMA, Multiplexing & Coding
 Class SDFTDSCDMA_DeCodeBlkSeg
 Derived From TDSCDMA_ChEncodingBase

Parameters

Name	Description	Default	Type	Range
DynTF_Set	dynamic part of Transport Format Set	244 488	int array	+
CRC	length of CRC bits: No_CRC, CRC_8_bits, CRC_12_bits, CRC_16_bits, CRC_24_bits	CRC_16_bits	enum	

ChCodingType	channel coding type: No_Coding, CC_HalfRate, CC_OneThirdRate, TurboCoding	CC_HalfRate	enum	
--------------	---	-------------	------	--

† The array structure of DynTF_Set is [transport block size 1, transport block set size 1, transport block size 2, transport block set size 2, ...] The value range of transport block size is [0, 5000]. The value range of transport block set size is [0, 20000]. Transport block set size must be an integer multiple of transport block size.

Pin Inputs

Pin	Name	Description	Signal Type
1	DataI	transport block set	int
2	TFI_I	transport format indicator	int

Pin Outputs

Pin	Name	Description	Signal Type
3	DataO	transport block set with CRC attached	int
4	TFI_O	transport format indicator	int

Notes/Equations

1. This model implements reverse process of transport block concatenation and code block segmentation.
2. Each firing, 1 TFI_I token and N DataO tokens are produced when 1 TFI_I and M DataI tokens consumed, while N and M is calculated using the maximum value of transport block set size, that is, the maximum valid data in one TTI after and before removing possible filler bits.
3. TFI value is an index used to select the transport block size and transport block set size from the transport format set, as specified by DynTF_Set. The minimal TFI is 0, the step is 1. The number of input and output tokens in each firing is calculated using the maximum value of transport block set size, while the valid tokens is calculated using the transport block set indexed by TFI.
4. All transport blocks in a TTI are serially concatenated. If the number of bits in a TTI is larger than the maximum size of a code block, then code block segmentation is performed after the concatenation of the transport blocks. The maximum size of the code blocks depends on whether convolutional, turbo coding or no coding is used for the TrCH.
Segmentation of the bit sequence from transport block concatenation is performed if $X_i > Z$. The code blocks after segmentation are of the same size. The number of code blocks on TrCH i is denoted by C_i . If the number of bits input to the segmentation, X_i , is not a multiple of C_i , filler bits are added to the beginning of the first block. If turbo coding is selected and $X_i < 40$, filler bits are added to the beginning of the code block. The filler bits are transmitted and they are always set to 0. The maximum code block sizes are:

convolutional coding: $Z = 504$
 turbo coding: $Z = 5114$
 no channel coding: $Z = \text{unlimited}$.

5. This model removes the possible filler bits.

References

1. 3GPP Technical Specification TS 25.222 V4.4.0, Multiplexing and channel coding (TDD) Release 4.

TDSCDMA_DePhyChMap



Description Physical channel demapping
 Library TDSCDMA, Multiplexing & Coding
 Class SDFTDSCDMA_DePhyChMap
 Derived From TDSCDMA_CCTrCH_Base

Parameters

Name	Description	Default	Type	Range
PhyChNum_SA	physical channel allocation configuration	0 0 1 0 0 0 0	int array	[0, 2] for Uplink, [0, 16] for Downlink
Link	link selection: Downlink, Uplink	Downlink	enum	
ModType_SA	type of modulation of all slots, 0 for QPSK, 1 for 8PSK	0 0 0 0 0 0 0	int array	{0, 1}

Pin Inputs

Pin	Name	Description	Signal Type
-----	------	-------------	-------------

Advanced Design System 2008

1	DataI	input data	multiple real
2	SlfFmtIn	input data slot format	multiple int

Pin Outputs

Pin	Name	Description	Signal Type
3	DataO	output data	multiple real
4	SizeOutM	output data length	multiple int

Notes/Equations

1. This model performs the inverse operation of physical channel mapping. Each firing, this model consumes 704×3 mapped tokens for each physical channel on multiple pin DataI, which is the maximum number of tokens one physical channel can contain in one subframe. 1 token for each physical channel on multiple pin SlfFmtIn is consumed to indicate the slot format index for the physical channel. 704×3 demapped tokens which consist of valid and padding ones are exported for each physical channel in one subframe on multiple pin DataO and 1 token is exported on multiple pin SizeOutM to indicate the number of valid tokens for the physical channel on DataO.
2. PhyChNum_SA indicates the number of physical channels allocated in each time slot.
3. For details regarding physical channel mapping algorithm, refer to [1].

References

1. 3GPP Technical Specification TS 25.222 V4.4.0, Multiplexing and channel coding (TDD) Release 4.

TDSCDMA_DePhyChSeg



Description Physical channel desegmentation
 Library TDSCDMA, Multiplexing & Coding

Advanced Design System 2008

Class SDFTDSCDMA_DePhyChSeg
 Derived From TDSCDMA_CCTrCH_MuxBase

Parameters				
Name	Description	Default	Type	Range
PhyChNum_SA	physical channel allocation configuration	0 0 1 0 0 0 0	int array	[0, 2] for Uplink, [0, 16] for Downlink
TrChNum	number of Transport Channels	2	int	[1, 32]
RM_TA	rate matching attributes of all Transport Channels	1 1	int array	[1, 256]
DynTF_Set_TA	dynamic part of TF set of all Transport Channels	100 100 244 244	int array	[0, 5000] for transport block size, [0, 20000] for transport block set size
TF_SetSize_TA	transport format set size of all Transport Channels	1 1	int array	[1, 64] for each element
TTI_TA	transmission time interval of all Transport Channels	2 1	int array	[0, 3] for each element
CRC_TA	number of CRC bits of all Transport Channels	2 3	int array	[0, 4] for each element
ChCodingType_TA	channel coding type of all Transport Channels	2 2	int array	[0, 3] for each element
PuncLimit	puncturing limit	2/3	real	(0, 1]
Link	link selection: Downlink, Uplink	Uplink	enum	
ModType_SA	type of modulation of all slots, 0 for QPSK, 1 for 8PSK	0 0 0 0 0 0 0	int array	[0, 1] for each element
TFCI_SA	allocated TFCI transmitted active slots configuration	0 0 1 0 0 0 0	int array	[0, 1] for each element
TFCI_Length_SA	length of TFCI of all slots	0 0 16 0 0 0 0	int array	{0, 4, 8, 16, 32} for QPSK, {0, 6, 12, 24,

Advanced Design System 2008

				48} for 8PSK
SS_TPC_SA	type of SS and TPC of all slots	2 2 1 2 2 2 2	int array	[1, 3]
MinSF_PA	minimum spreading factor array corresponding to allocated physical channels	8	int array	{1, 2,4,8,16} for Uplink, {1,16} for Downlink
NdataOption	the two options to determine the number Ndata: Minimum, Autonomous	Minimum	enum	

Pin Inputs

Pin	Name	Description	Signal Type
1	TFCI	transport format combination indicator	int
2	DataIn	input data	multiple real

Pin Outputs

Pin	Name	Description	Signal Type
3	DataOut	output data	real

Notes/Equations

- This model is used to perform physical channel desegmentation, the inverse operation of physical channel segmentation.
Each firing, MAX_BIT_SLOT tokens for each physical channel are consumed for each physical channel at multiple pin DataIn, in which MAX_BIT_SLOT is the possible maximum number of tokens in one physical channel, that is $704 \times 3 \times 2$; 1 token consumed at TFCI indicates the value of transport format combination indicator; $bm_PhyChNumAll \times MAX_BIT_SLOT$ tokens are exported at DataOut, in which $bm_PhyChNumAll$ is the number of allocated physical channels.
- Each firing, this model consumes the tokens in all allocated physical channels and combines them into one CCTrCH data block.
The bits input to the physical channel desegmentation are denoted by $u_{p1}, u_{p2}, u_{p3}, \dots, u_p, U_p$, $p = 1, 2, \dots, P$, where p is physical channel number and U_p is the number of bits in physical channel p , P is number of physical channels. The output bits are denoted by $x_1, x_2, x_3, \dots, x_Y$, where $Y = U_1 + U_2 + \dots + U_P$. The relation between x_k and u_{pk} is given below.

$$u_{1,k} = x_{i,k} \quad k = 1, 2, \dots, U_1$$

$$u_{2,k} = x_{i,k+U} \quad k = 1, 2, \dots, U_2$$

$$u_{P,k} = x_{i,k+(P-1)U} \quad k = 1, 2, \dots, U_P$$

The $x_1, x_2, x_3, \dots, x_Y$ is exported at DataOut, if Y is less than $bm_PhyChNumAll \times MAX_BIT_SLOT$, padding bits (0) are added.

- All transport channel information must be provided in the form of arrays. For DynTF_Set_TA the correct form is transport block size 1, transport block set size 1, transport block size 2, transport block set size 2, etc. The size of this array must be a multiple of 2, and the transport block set size must be a multiple of the relative transport block size. When setting TTI_TA, CRC_TA and ChCodingType_TA, refer to the following table.

Array Values

TTI_TA		CRC_TA		ChCodingType_TA	
Time	Value	Coding	Value	Coding	Value
10ms	0	No CRC	0	No Coding	0
20ms	1	8 bits	1	1/2 CC	1
40ms	2	12 bits	2	1/3 CC	2
80ms	3	16 bits	3	1/3 TC	3
		24 bits	4		

CC = convolutional coding; TC = turbo coding

- PunLimit denotes the variable PL defined in [2]. Refer to [2] for details regarding use of this variable in rate matching algorithm.
- PhyChNum_SA indicates the number of allocated physical channels in each slot. The sum of PhyChNum_SA elements is the number of allocated physical channels.
- TFCI_SA indicates in which slots TFCI bits will be transmitted. 0 denotes no TFCI bits will be transmitted in the slot. 1 denotes TFCI bits can be transmitted in the slot. The setting must be consistent with PhyChNum_SA setting, which means TFCI bits can only be transmitted in those slots in which the elements of PhyChNum_SA are not zero. Only the first allocated physical channel in each slot is used to transmit TFCI bits.
- TFCI_Length_SA indicates the number of TFCI bits transmitted in each slot. If 0 is selected, the number of TFCI bits transmitted in the slot is dependent on the value of TFCI imported at TFCI pin. If a non-zero is selected, the number of TFCI bits transmitted in the slot is this non-zero value.
- MinSF_PA indicates the minimum spread factor that can be used for corresponding physical channel. The size of MinSF_PA must be equal to the sum of PhyChNum_SA elements.
- NdataOption specifies how the target number of rate-matched data is calculated with MinSF_PA. For Downlink, only Minimum can be selected. For Uplink, both can be selected. Refer to [2] for details.
- SS_TPC_SA indicates the number of SS and TPC symbols transmitted in each slot. 1 denotes one SS and one TPC symbols are transmitted in the slot; 2 denotes no SS and no TPC symbols are transmitted in the slot; 3

denotes 16/SF SS and 16/SF TPC symbols are transmitted in the slot, where SF is the spreading factor of the physical channel used to transmitted SS and TPC symbols. Only the first allocated physical channel in each slot is used to transmit SS and TPC symbols.

References

1. 3GPP Technical Specification TS 25.221 V4.5.0, Physical channels and mapping of transport channels (TDD) Release 4.
2. 3GPP Technical Specification TS 25.222 V4.4.0, Multiplexing and channel coding (TDD) Release 4.
3. 3GPP Technical Specification TS 25.223 V4.4.0, Spreading and modulation (TDD) Release 4.
4. 3GPP Technical Specification TS 25.224 V4.5.0, Physical layer procedures (TDD) 4.

TDSCDMA_DeRadioEqual



Description Radio frame size deequalization
 Library TDSCDMA, Multiplexing & Coding
 Class SDFTDSCDMA_DeRadioEqual
 Derived From TDSCDMA_ChDecodingBase

Parameters

Name	Description	Default	Type	Range
DynTF_Set	dynamic part of Transport Format Set	244 488	int array	†
TTI	transmission time interval: TTI_10ms, TTI_20ms, TTI_40ms, TTI_80ms	TTI_10ms	enum	
CRC	length of CRC bits: No_CRC, CRC_8_bits,	CRC_16_bits	enum	

	CRC_12_bits, CRC_16_bits, CRC_24_bits			
ChCodingType	channel coding type: No_Coding, CC_HalfRate, CC_OneThirdRate, TurboCoding	CC_HalfRate	enum	

† The array structure of DynTF_Set is [transport block size 1, transport block set size 1, transport block size 2, transport block set size 2, ...] The value range of transport block size is [0, 5000]. The value range of transport block set size is [0, 20000]. Transport block set size must be an integer multiple of transport block size.

Pin Inputs

Pin	Name	Description	Signal Type
1	DataI	input data	real
2	TFI_I	transport format indicator	int

Pin Outputs

Pin	Name	Description	Signal Type
3	DataO	output data	real
4	TFI_O	transport format indicator	int

Notes/Equations

1. This model implements reverse process of radio frame size equalization.
2. Each firing, 1 TFI_I token and N DataO tokens are produced when 1 TFI_I and M DataI tokens consumed, while N and M are calculated using the maximum value of transport block set size, that is, the maximum valid data in one TTI after and before radio frame size deequalization.
3. TFI value is an index used to select the transport block size and transport block set size from the transport format set, as specified by DynTF_Set. The minimal TFI is 0, the step is 1. The number of input and output tokens in each firing is calculated using the maximum value of transport block set size, while the valid tokens is calculated using the transport block set indexed by TFI.
4. Radio frame size equalization is padding the input bit sequence in order to ensure that the output can be averaged into radio frames if the number of radio frames in one TTI is larger than 1.
5. Radio frame size deequalization removes the padding bits.

References

1. 3GPP Technical Specification TS 25.222 V4.4.0, Multiplexing and channel coding (TDD) Release 4.

TDSCDMA_DeRadioSeg



Description Radio frame desegmentation
 Library TDSCDMA, Multiplexing & Coding
 Class SDFTDSCDMA_DeRadioSeg
 Derived From TDSCDMA_ChDecodingBase

Parameters

Name	Description	Default	Type	Range
DynTF_Set	dynamic part of Transport Format Set	244 488	int array	†
TTI	transmission time interval: TTI_10ms, TTI_20ms, TTI_40ms, TTI_80ms	TTI_10ms	enum	
CRC	length of CRC bits: No_CRC, CRC_8_bits, CRC_12_bits, CRC_16_bits, CRC_24_bits	CRC_16_bits	enum	
ChCodingType	channel coding type: No_Coding, CC_HalfRate, CC_OneThirdRate, TurboCoding	CC_HalfRate	enum	

† The array structure of DynTF_Set is [transport block size 1, transport block set size 1, transport block size 2, transport block set size 2, ...] The value range of transport block size is [0, 5000]. The value range of transport block set size is [0, 20000]. Transport block set size must be an integer multiple of transport block size.

Advanced Design System 2008

Pin Inputs

Pin	Name	Description	Signal Type
1	DataI	input data	real
2	TFI_I	transport format indicator	int

Pin Outputs

Pin	Name	Description	Signal Type
3	DataO	output data	real
4	TFI_O	transport format indicator	int

Notes/Equations

1. This model implements the reverse process of radio frame segmentation.
2. Each firing, 1 TFI_I token and N DataO tokens are produced when 1 TFI_I and N DataI tokens are consumed, while N is calculated using the maximum value of transport block set size, that is, the maximum valid data in one TTI.
3. The TFI value is an index used to select the transport block size and transport block set size from the transport format set, as specified by DynTF_Set. The minimum TFI is 0, the step is 1. The number of input and output tokens in each firing is calculated using the maximum value of transport block set size, while the valid tokens are calculated using the transport block set indexed by TFI.
4. When the transmission time interval is longer than 10 msec, the input bit sequence on consecutive Fi radio frames is combined and mapped onto one TTI.

References

1. 3GPP Technical Specification TS 25.222 V4.4.0, Multiplexing and channel coding (TDD) Release 4.

TDSCDMA_DeRateMatch



Description Derate match

Library TDSCDMA, Multiplexing & Coding

Class SDFTDSCDMA_DeRateMatch

Derived From TDSCDMA_CCTrCH_MuxBase

Parameters

Name	Description	Default	Type	Range
PhyChNum_SA	physical channel allocation configuration	0 0 1 0 0 0 0	int array	[0, 2] for Uplink, [0, 16] for Downlink
TrChNum	number of Transport Channels	2	int	[1, 32]
RM_TA	rate matching attributes of all Transport Channels	1 1	int array	[1, 256]
DynTF_Set_TA	dynamic part of TF set of all Transport Channels	100 100 244 244	int array	[0, 5000] for transport block size, [0, 20000] for transport block set size
TF_SetSize_TA	transport format set size of all Transport Channels	1 1	int array	[1, 64] for each element
TTI_TA	transmission time interval of all Transport Channels	2 1	int array	[0, 3] for each element
CRC_TA	number of CRC bits of all Transport Channels	2 3	int array	[0, 4] for each element
ChCodingType_TA	channel coding type of all Transport Channels	2 2	int array	[0, 3] for each element
PuncLimit	puncturing limit	2/3	real	(0, 1]

Advanced Design System 2008

Link	link selection: Downlink, Uplink	Uplink	enum	
ModType_SA	type of modulation of all slots, 0 for QPSK, 1 for 8PSK	0 0 0 0 0 0 0	int array	[0, 1] for each element
TFCI_SA	allocated TFCI transmitted active slots configuration	0 0 1 0 0 0 0	int array	[0, 1] for each element
TFCI_Length_SA	length of TFCI of all slots	0 0 16 0 0 0 0	int array	{0, 4, 8, 16, 32} for QPSK, {0, 6, 12, 24, 48} for 8PSK
SS_TPC_SA	type of SS and TPC of all slots	2 2 1 2 2 2 2	int array	[1, 3]
MinSF_PA	minimum spreading factor array corresponding to allocated physical channels	8	int array	{1, 2,4,8,16} for Uplink, {1,16} for Downlink
NdataOption	the two options to determine the number Ndata: Minimum, Autonomous	Minimum	enum	
TrChIndex	index of Transport Channels	1	int	[1, TrChNum]

† The array structure of DynTF_Set_TA is [transport block size 1, transport block set size 1, transport block size 2, transport block set size 2,...] The value range of transport block size is [0, 5000]. The value range of transport block set size is [0, 20000]. Transport block set size must be an integer multiple of transport block size.

Pin Inputs

Pin	Name	Description	Signal Type
1	DataIn	input data	real
2	TFCI	transport channel combination indicator	int

Pin Outputs

Pin	Name	Description	Signal Type
3	DataOut	output data	real

Notes/Equations

1. This model is used to perform derate matching, the inverse operation of rate matching. Each firing, 1 token consumed at TFCI indicates the value of transport format combination indicator. The maximum number of rate-matched tokens in one frame for all transport channels involved in rate matching are consumed at DataIn and the possible maximum number of tokens in one frame for all transport formats of the transport channel specified by TrChIndex exported at DataOut each firing.
2. Derate matching means removing the repeated tokens which are added in the rate matching or insert zeros where the tokens are punctured in the rate matching.
3. Higher layers assign a rate-matching attribute for each transport channel. This attribute is semi-static and can only be changed through higher layer signaling. The rate-matching attribute is used when the number of bits to be repeated or punctured is calculated. RM_TA is provided so that users can set the semi-static attributes for each transport channel.

The number of bits on a transport channel can vary between different transmission time intervals. When the number of bits between different transmission time intervals changes, bits are repeated or punctured to ensure that the total bit rate after TrCh multiplexing is the same as the total channel bit rate of the allocated physical channels.

For rate matching algorithm details, refer to [2].

4. All transport channel information must be provided in the form of arrays.
For DynTF_Set_TA the correct form is transport block size 1, transport block set size 1, transport block size 2, transport block set size 2, etc. The size of this array must be a multiple of 2, and the transport block set size must be a multiple of the relative transport block size.
When setting TTI_TA, CRC_TA and ChCodingType_TA, refer to the following table.

Array Values

TTI_TA		CRC_TA		ChCodingType_TA	
Time	Value	Coding	Value	Coding	Value
10ms	0	No CRC	0	No Coding	0
20ms	1	8 bits	1	1/2 CC	1
40ms	2	12 bits	2	1/3 CC	2
80ms	3	16 bits	3	1/3 TC	3
		24 bits	4		

CC = convolutional coding; TC = turbo coding

5. PunctLimit denotes the variable PL defined in [2]. Refer to [2] for details regarding use of this variable in rate matching algorithm.
6. PhyChNum_SA indicates the number of allocated physical channels in each slot. The sum of PhyChNum_SA elements is the number of allocated physical channels.
7. TFCI_SA indicates in which slots TFCI bits will be transmitted. 0 denotes no TFCI bits will be transmitted in the slot. 1 denotes TFCI bits can be transmitted in the slot. The setting must be consistent with PhyChNum_SA setting, which means TFCI bits can only be transmitted in those slots in which the elements of PhyChNum_SA are not zero. Only the first allocated physical channel in each slot is used to transmit TFCI bits.
8. TFCI_Length_SA indicates the number of TFCI bits transmitted in each slot. If 0 is selected, the number of TFCI bits transmitted in the slot is dependent on the value of TFCI imported at TFCI pin. If a non-zero is selected, the

number of TFCI bits transmitted in the slot is this non-zero value.

9. MinSF_PA indicates the minimum spread factor that can be used for corresponding physical channel. The size of MinSF_PA must be equal to the sum of PhyChNum_SA elements.
10. NdataOption specifies how the target number of rate-matched data is calculated with MinSF_PA. For Downlink, only Minimum can be selected. For Uplink, both can be selected. Refer to [2] for details.
11. SS_TPC_SA indicates the number of SS and TPC symbols transmitted in each slot. 1 denotes one SS and one TPC symbols are transmitted in the slot; 2 denotes no SS and no TPC symbols are transmitted in the slot; 3 denotes 16/SF SS and 16/SF TPC symbols are transmitted in the slot, where SF is the spreading factor of the physical channel used to transmitted SS and TPC symbols. Only the first allocated physical channel in each slot is used to transmit SS and TPC symbols.

References

1. 3GPP Technical Specification TS 25.221 V4.5.0, Physical channels and mapping of transport channels (TDD) Release 4.
2. 3GPP Technical Specification TS 25.222 V4.4.0, Multiplexing and channel coding (TDD) Release 4.
3. 3GPP Technical Specification TS 25.223 V4.4.0, Spreading and modulation (TDD) Release 4.
4. 3GPP Technical Specification TS 25.224 V4.5.0, Physical layer procedures (TDD) 4.

TDSCDMA_DeSubFrameSeg



Description Subframe desegmentation
 Library TDSCDMA, Multiplexing & Coding
 Class SDFTDSCDMA_DeSubFrameSeg
 Derived From TDSCDMA_CCTrCH_Base

Parameters

Name	Description	Default	Type	Range
PhyChNum_SA	physical channel allocation configuration	0 0 1 0 0 0 0	int array	[0, 2] for Uplink, [0, 16] for Downlink

Pin Inputs

Pin	Name	Description	Signal Type
1	DataI	input data	multiple real
2	SizeInM	input data length	multiple int

Pin Outputs

Pin	Name	Description	Signal Type
3	DataO	output data	multiple real
4	SizeOutM	output data length	multiple int

Notes/Equations

1. This model performs subframe desegmentation on subframes for each physical channel. Each firing, this model consumes $704 \times 3 \times 2$ tokens for each physical channel on multiple pin DataI, 2 tokens for each physical channel on multiple pin SizeInM, and exports $704 \times 3 \times 2$ tokens for each physical channel on multiple pin DataO, 1 token for each physical channel on multiple pin SizeOutM.
2. PhyChNum_SA indicates the number of physical channels allocated in each time slot.
3. Each firing, two subframes constructing one frame are consumed on DataI for each physical channel, which contains $704 \times 3 \times 2$ tokens, the maximum number of tokens one frame can contain for one physical channel. Each subframe consists of valid tokens and zero padding tokens. The number of valid tokens is specified by the token consumed on SizeInM. If the value of this token is L, the model combines the first L tokens of the first subframe with the first L tokens of the second subframe and exports them with $704 \times 3 \times 2 - 2 \times L$ padding tokens followed on multiple pin DataO for each physical channel. And the number of valid tokens in one frame $2 \times L$ is exported on multiple pin SizeOutM for each physical channel.

References

1. 3GPP Technical Specification TS 25.222 V4.4.0, Multiplexing and channel coding (TDD) Release 4.

TDSCDMA_PhyChMap



Description Physical channel mapping
 Library TDSCDMA, Multiplexing & Coding
 Class SDFTDSCDMA_PhyChMap
 Derived From TDSCDMA_CCTrCH_Base

Parameters

Name	Description	Default	Type	Range
PhyChNum_SA	physical channel allocation configuration	0 0 1 0 0 0 0	int array	[0, 2] for Uplink, [0, 16] for Downlink
Link	link selection: Downlink, Uplink	Downlink	enum	
ModType_SA	type of modulation of all slots, 0 for QPSK, 1 for 8PSK	0 0 0 0 0 0 0	int array	{0, 1}

Pin Inputs

Pin	Name	Description	Signal Type
1	DataI	input data	multiple int
2	SlfFmtIn	input data slot format	multiple int

Pin Outputs

Pin	Name	Description	Signal Type
3	DataO	output data	multiple int
4	SlfFmtOut	output data slot format	multiple int

Notes/Equations

1. This model performs physical channel mapping. Each firing, this model consumes 704×3 tokens for each physical channel on multiple pin DataI, which is the maximum number of tokens one physical channel can contain in one subframe. 1 token for each physical channel on multiple pin SlfFmtIn is consumed to indicate the slot format index for the physical channel. 704×3 mapped tokens are exported for each physical channel in one subframe on multiple pin DataO and 1 token is exported on multiple pin SlfFmtOut to indicate the slot format index for the physical channel.
2. PhyChNum_SA indicates the number of physical channels allocated in each time slot.
3. For details regarding physical channel mapping algorithm, refer to [1].

References

1. 3GPP Technical Specification TS 25.222 V4.4.0, Multiplexing and channel coding (TDD) Release 4.

TDSCDMA_PhyChSeg



Description Physical channel segmentation
 Library TDSCDMA, Multiplexing & Coding
 Class SDFTDSCDMA_PhyChSeg
 Derived From TDSCDMA_CCTrCH_MuxBase

Parameters

Name	Description	Default	Type	Range
PhyChNum_SA	physical channel allocation configuration	0 0 1 0 0 0 0	int array	[0, 2] for Uplink, [0, 16] for Downlink
TrChNum	number of Transport Channels	2	int	[1, 32]
RM_TA	rate matching attributes of all Transport Channels	1 1	int array	[1, 256]
DynTF_Set_TA	dynamic part of TF set of all Transport Channels	100 100 244 244	int array	[0, 5000] for transport block size, [0, 20000] for transport block set size
TF_SetSize_TA	transport format set size of all Transport Channels	1 1	int array	[1, 64] for each element
TTI_TA	transmission time interval of all	2 1	int array	[0, 3] for each element

Advanced Design System 2008

	Transport Channels			
CRC_TA	number of CRC bits of all Transport Channels	2 3	int array	[0, 4] for each element
ChCodingType_TA	channel coding type of all Transport Channels	2 2	int array	[0, 3] for each element
PuncLimit	puncturing limit	2/3	real	(0, 1]
Link	link selection: Downlink, Uplink	Uplink	enum	
ModType_SA	type of modulation of all slots, 0 for QPSK, 1 for 8PSK	0 0 0 0 0 0	int array	[0, 1] for each element
TFCI_SA	allocated TFCI transmitted active slots configuration	0 0 1 0 0 0	int array	[0, 1] for each element
TFCI_Length_SA	length of TFCI of all slots	0 0 16 0 0 0	int array	{0, 4, 8, 16, 32} for QPSK, {0, 6, 12, 24, 48} for 8PSK
SS_TPC_SA	type of SS and TPC of all slots	2 2 1 2 2 2	int array	[1, 3]
MinSF_PA	minimum spreading factor array corresponding to allocated physical channels	8	int array	{1, 2,4,8,16} for Uplink, {1,16} for Downlink
NdataOption	the two options to determine the number Ndata: Minimum, Autonomous	Minimum	enum	

Pin Inputs

Pin	Name	Description	Signal Type
1	DataIn	input data	int
2	TFCI	transport format combination indicator	int

Pin Outputs

Pin	Name	Description	Signal Type
3	DataOut	output data	multiple int
4	SizeOutM	output data length	multiple int
5	SlfFmtOut	slot format of each physical channel	multiple int

Notes/Equations

1. This model is used to perform physical channel segmentation.

Each firing, $bm_PhyChNumAll \times MAX_BIT_SLOT$ tokens are consumed at DataIn, in which $bm_PhyChNumAll$ is the number of allocated physical channels and MAX_BIT_SLOT is the possible maximum number of bits in one physical channel, that is $704 \times 3 \times 2$; 1 token consumed at TFCI indicates the value of transport format combination indicator; MAX_BIT_SLOT tokens for each physical channel are exported at multiple pin DataOut which include valid tokens and padding tokens; 1 token is exported for each physical channel at multiple pin SizeOutM which indicates the number of valid tokens; 2 tokens are exported for each physical channel at multiple pin SlfFmtOut which indicate the slot format of each physical channel.

2. Each firing, this model consumes one CCTrCH data block from the DataIn pin. When more than one physical channel is used, physical channel segmentation divides the CCTrCH data block among different physical channels.

The bits input to the physical channel segmentation are denoted by $x_1, x_2, x_3, \dots, x_Y$, where Y is the number of bits input to the physical channel segmentation block. The number of physical channels is denoted by P. Bits after physical channel segmentation are denoted $u_{p1}, u_{p2}, u_{p3}, \dots, u_p, U_p'$ where p is physical channel number and U_p is the number of bits in physical channel p. The relation between x_k and u_{pk} is given below.

- Bits on first physical channel after physical channel segmentation:

$$u_{1,k} = x_{i,k} \quad k = 1, 2, \dots, U_1$$

- Bits on second physical channel after physical channel segmentation:

$$u_{2,k} = x_{i,k+U} \quad k = 1, 2, \dots, U_2$$

- Bits on the Pth physical channel after physical channel segmentation:

$$u_{P,k} = x_{i,k+(P-1)U} \quad k = 1, 2, \dots, U_P$$

The resulting physical channels are exported at DataOut, if U_p ($p=1,2,\dots,P$) is less than MAX_BIT_SLOT , padding bits(0) are added.

3. All transport channel information must be provided in the form of arrays.

For DynTF_Set_TA the correct form is transport block size 1, transport block set size 1, transport block size 2, transport block set size 2, etc. The size of this array must be a multiple of 2, and the transport block set size must be a multiple of the relative transport block size.

When setting TTI_TA, CRC_TA and ChCodingType_TA, refer to the following table.

Array Values

TTI_TA		CRC_TA		ChCodingType_TA	
Time	Value	Coding	Value	Coding	Value
10ms	0	No CRC	0	No Coding	0
20ms	1	8 bits	1	1/2 CC	1
40ms	2	12 bits	2	1/3 CC	2
80ms	3	16 bits	3	1/3 TC	3
		24 bits	4		

CC = convolutional coding; TC = turbo coding

4. PunctLimit denotes the variable PL defined in [2]. Refer to [2] for details regarding use of this variable in rate matching algorithm.
5. PhyChNum_SA indicates the number of allocated physical channels in each slot. The sum of PhyChNum_SA elements is the number of allocated physical channels.
6. TFCI_SA indicates in which slots TFCI bits will be transmitted. 0 denotes no TFCI bits will be transmitted in the slot. 1 denotes TFCI bits can be transmitted in the slot. The setting must be consistent with PhyChNum_SA setting, which means TFCI bits can only be transmitted in those slots in which the elements of PhyChNum_SA are not zero. Only the first allocated physical channel in each slot is used to transmit TFCI bits.
7. TFCI_Length_SA indicates the number of TFCI bits transmitted in each slot. If 0 is selected, the number of TFCI bits transmitted in the slot is dependent on the value of TFCI imported at TFCI pin. If a non-zero is selected, the number of TFCI bits transmitted in the slot is this non-zero value.
8. MinSF_PA indicates the minimum spread factor that can be used for corresponding physical channel. The size of MinSF_PA must be equal to the sum of PhyChNum_SA elements.
9. NdataOption specifies how the target number of rate-matched data is calculated with MinSF_PA. For Downlink, only Minimum can be selected. For Uplink, both can be selected. Refer to [2] for details.
10. SS_TPC_SA indicates the number of SS and TPC symbols transmitted in each slot. 1 denotes one SS and one TPC symbols are transmitted in the slot; 2 denotes no SS and no TPC symbols are transmitted in the slot; 3 denotes 16/SF SS and 16/SF TPC symbols are transmitted in the slot, where SF is the spreading factor of the physical channel used to transmitted SS and TPC symbols. Only the first allocated physical channel in each slot is used to transmit SS and TPC symbols.

References

1. 3GPP Technical Specification TS 25.221 V4.5.0, Physical channels and mapping of transport channels (TDD) Release 4.
2. 3GPP Technical Specification TS 25.222 V4.4.0, Multiplexing and channel coding (TDD) Release 4.
3. 3GPP Technical Specification TS 25.223 V4.4.0, Spreading and modulation (TDD) Release 4.
4. 3GPP Technical Specification TS 25.224 V4.5.0, Physical layer procedures (TDD) 4.

TDSCDMA_RadioEqual



Description Radio frame size equalization
 Library TDSCDMA, Multiplexing & Coding
 Class SDFTDSCDMA_RadioEqual
 Derived From TDSCDMA_ChEncodingBase

Parameters

Name	Description	Default	Type	Range
DynTF_Set	dynamic part of Transport Format Set	244 488	int array	†
TTI	transmission time interval: TTI_10ms, TTI_20ms, TTI_40ms, TTI_80ms	TTI_10ms	enum	
CRC	length of CRC bits: No_CRC, CRC_8_bits, CRC_12_bits, CRC_16_bits, CRC_24_bits	CRC_16_bits	enum	
ChCodingType	channel coding type: No_Coding, CC_HalfRate, CC_OneThirdRate, TurboCoding	CC_HalfRate	enum	

† The array structure of DynTF_Set is [transport block size 1, transport block set size 1, transport block size 2, transport block set size 2, ...] The value range of transport block size is [0, 5000]. The value range of transport block set size is [0, 20000]. Transport block set size must be an integer multiple of transport block size.

Pin Inputs

Pin	Name	Description	Signal Type
1	DataI	transport block set	int

2	TFI_I	transport format indicator	int
---	-------	----------------------------	-----

Pin Outputs

Pin	Name	Description	Signal Type
3	DataO	transport block set with CRC attached	int
4	TFI_O	transport format indicator	int

Notes/Equations

1. This model implements radio frame size equalization.
 Each firing, 1 TFI_I token and N DataO tokens are produced when 1 TFI_I and M DataI tokens are consumed, while N and M are calculated using the maximum value of transport block set size; that is, the maximum valid data in one TTI before and after radio frame size equalization.
 The value of TFI is an index used to select the transport block size and transport block set size from the transport format set, as specified by DynTF_Set. The minimum TFI is 0, the step is 1. The number of input and output tokens in each firing is calculated using the maximum value of transport block set size, while the valid tokens are calculated using the transport block set indexed by TFI.
2. Radio frame size equalization is padding the input bit sequence in order to ensure that the output can be averaged into radio frames if the number of radio frames in one TTI is larger than 1.

References

1. 3GPP Technical Specification TS 25.222 V4.4.0, Multiplexing and channel coding (TDD) Release 4.

TDSCDMA_RadioSeg



Description Radio frame segmentation
 Library TDSCDMA, Multiplexing & Coding

Advanced Design System 2008

Class SDFTDSCDMA_RadioSeg

Derived From TDSCDMA_ChEncodingBase

Parameters

Name	Description	Default	Type	Range
DynTF_Set	dynamic part of Transport Format Set	244 488	int array	†
TTI	transmission time interval: TTI_10ms, TTI_20ms, TTI_40ms, TTI_80ms	TTI_10ms	enum	
CRC	length of CRC bits: No_CRC, CRC_8_bits, CRC_12_bits, CRC_16_bits, CRC_24_bits	CRC_16_bits	enum	
ChCodingType	channel coding type: No_Coding, CC_HalfRate, CC_OneThirdRate, TurboCoding	CC_HalfRate	enum	

† The array structure of DynTF_Set is [transport block size 1, transport block set size 1, transport block size 2, transport block set size 2,+...] The value range of transport block size is [0, 5000]. The value range of transport block set size is [0, 20000]. Transport block set size must be an integer multiple of transport block size.

Pin Inputs

Pin	Name	Description	Signal Type
1	DataI	transport block set	int
2	TFI_I	transport format indicator	int

Pin Outputs

Pin	Name	Description	Signal Type
3	DataO	transport block set with CRC attached	int
4	TFI_O	transport format indicator	int

Notes/Equations

1. This model implements radio frame segmentation.
 Each firing, 1 TFI_I token and N DataO tokens are produced when 1 TFI_I and N DataI tokens consumed, while N is calculated using the maximum value of transport block set size, that is, the maximum valid data in one TTI. TFI value is an index used to select the transport block size and transport block set size from the transport format set, as specified by DynTF_Set. The minimum TFI is 0, the step is 1. The number of input and output tokens in each firing is calculated using the maximum value of transport block set size, while the valid tokens are calculated using the transport block set indexed by TFI.
2. When the transmission time interval is longer than 10 ms, the input bit sequence is segmented and mapped onto consecutive Fi radio frames. After radio frame size equalization the input bit sequence length is guaranteed to be an integer multiple of F i.

References

1. 3GPP Technical Specification TS 25.222 V4.4.0, Multiplexing and channel coding (TDD) Release 4.

TDSCDMA_RateMatch



Description Rate match
 Library TDSCDMA, Multiplexing & Coding
 Class SDFTDSCDMA_RateMatch
 Derived From TDSCDMA_CCTrCH_MuxBase

Parameters

Name	Description	Default	Type	Range
PhyChNum_SA	physical channel allocation configuration	0 0 1 0 0 0 0	int array	[0, 2] for Uplink, [0,+16] for Downlink

Advanced Design System 2008

TrChNum	number of Transport Channels	2	int	[1, 32]
RM_TA	rate matching attributes of all Transport Channels	1 1	int array	[1, 256]
DynTF_Set_TA	dynamic part of TF set of all Transport Channels	100 100 244 244	int array	[0, 5000] for transport block size, [0,+20000] for transport block set size
TF_SetSize_TA	transport format set size of all Transport Channels	1 1	int array	[1, 64] for each element
TTI_TA	transmission time interval of all Transport Channels	2 1	int array	[0, 3] for each element
CRC_TA	number of CRC bits of all Transport Channels	2 3	int array	[0, 4] for each element
ChCodingType_TA	channel coding type of all Transport Channels	2 2	int array	[0, 3] for each element
PuncLimit	puncturing limit	2/3	real	(0, 1]
Link	link selection: Downlink, Uplink	Uplink	enum	
ModType_SA	type of modulation of all slots, 0 for QPSK, 1 for 8PSK	0 0 0 0 0 0	int array	[0, 1] for each element
TFCI_SA	allocated TFCI transmitted active slots configuration	0 0 1 0 0 0 0	int array	[0, 1] for each element
TFCI_Length_SA	length of TFCI of all slots	0 0 16 0 0 0 0	int array	{0, 4, 8, 16, 32} for QPSK, {0, 6, 12, 24, 48} for 8PSK
SS_TPC_SA	type of SS and TPC of all slots	2 2 1 2 2 2 2	int array	[1, 3]
MinSF_PA	minimum spreading factor array corresponding to allocated physical channels	8	int array	{1, 2,4,8,16} for Uplink, {1,16} for Downlink

NdataOption	the two options to determine the number Ndata: Minimum, Autonomous	Minimum	enum	
TrChIndex	index of Transport Channels	1	int	[1, TrChNum]

† The array structure of DynTF_Set_TA is [transport block size 1, transport block set size 1, transport block size 2, transport block set size 2, ...]. The value range of transport block size is [0, 5000]. The value range of transport block set size is [0, 20000]. transport block set size must be an integer multiple of transport block size.

Pin Inputs

Pin	Name	Description	Signal Type
1	DataIn	input data	int
2	TFCI	transport channel combination indicator	int

Pin Outputs

Pin	Name	Description	Signal Type
3	DataOut	output data	int

Notes/Equations

1. This model is used to perform rate matching.
Each firing, 1 token consumed at TFCI indicates the value of transport format combination indicator. The maximum number of tokens possible in one frame for all transport formats of the channel specified by TrChIndex are consumed at DataIn; the maximum number of rate-matched tokens in one frame for all transport channels involved in rate matching are exported at DataOut.
2. Rate matching means that bits on a transport channel are repeated or punctured. Higher layers assign a rate-matching attribute for each transport channel. This attribute is semi-static and can only be changed through higher layer signaling. The rate-matching attribute is used when the number of bits to be repeated or punctured is calculated. RM_TA is provided so that users can set the semi-static attributes for each transport channel. The number of bits on a transport channel can vary between different transmission time intervals. When the number of bits between different transmission time intervals changes, bits are repeated or punctured to ensure that the total bit rate after TrCh multiplexing is the same as the total channel bit rate of the allocated physical channels.
For rate matching algorithm details, refer to [2].
3. All transport channel information must be provided in the form of arrays.
For DynTF_Set_TA the correct form is transport block size 1, transport block set size 1, transport block size 2, transport block set size 2, etc. The size of this array must be a multiple of 2, and the transport block set size

must be a multiple of the relative transport block size.

When setting TTI_TA, CRC_TA and ChCodingType_TA, refer to the following table.

Array Values

TTI_TA		CRC_TA		ChCodingType_TA	
Time	Value	Coding	Value	Coding	Value
10ms	0	No CRC	0	No Coding	0
20ms	1	8 bits	1	1/2 CC	1
40ms	2	12 bits	2	1/3 CC	2
80ms	3	16 bits	3	1/3 TC	3
		24 bits	4		

CC = convolutional coding; TC = turbo coding

4. PunctLimit denotes the variable PL defined in [2]. Refer to [2] for details regarding use of this variable in rate matching algorithm.
5. PhyChNum_SA indicates the number of allocated physical channels in each slot. The sum of PhyChNum_SA elements is the number of allocated physical channels.
6. TFCI_SA indicates in which slots TFCI bits will be transmitted. 0 denotes no TFCI bits will be transmitted in the slot. 1 denotes TFCI bits can be transmitted in the slot. The setting must be consistent with PhyChNum_SA setting, which means TFCI bits can only be transmitted in those slots in which the elements of PhyChNum_SA are not zero. Only the first allocated physical channel in each slot is used to transmit TFCI bits.
7. TFCI_Length_SA indicates the number of TFCI bits transmitted in each slot. If 0 is selected, the number of TFCI bits transmitted in the slot is dependent on the value of TFCI imported at TFCI pin. If a non-zero is selected, the number of TFCI bits transmitted in the slot is this non-zero value.
8. MinSF_PA indicates the minimum spread factor that can be used for corresponding physical channel. The size of MinSF_PA must be equal to the sum of PhyChNum_SA elements.
9. NdataOption specifies how the target number of rate-matched data is calculated with MinSF_PA. For Downlink, only Minimum can be selected. For Uplink, both can be selected. Refer to [2] for details.
10. SS_TPC_SA indicates the number of SS and TPC symbols transmitted in each slot. 1 denotes one SS and one TPC symbols are transmitted in the slot; 2 denotes no SS and no TPC symbols are transmitted in the slot; 3 denotes 16/SF SS and 16/SF TPC symbols are transmitted in the slot, where SF is the spreading factor of the physical channel used to transmitted SS and TPC symbols. Only the first allocated physical channel in each slot is used to transmit SS and TPC symbols.

References

1. 3GPP Technical Specification TS 25.221 V4.5.0, Physical channels and mapping of transport channels (TDD) Release 4.
2. 3GPP Technical Specification TS 25.222 V4.4.0, Multiplexing and channel coding (TDD) Release 4.
3. 3GPP Technical Specification TS 25.223 V4.4.0, Spreading and modulation (TDD) Release 4.
4. 3GPP Technical Specification TS 25.224 V4.5.0, Physical layer procedures (TDD) 4.

TDSCDMA_RefChDecoder



Description TDSCDMA reference measurement channel decoder
 Library TDSCDMA, Multiplexing & Coding
 Class SDFTDSCDMA_RefChDecoder

Parameters

Name	Description	Default	Type	Range
Link	link selection: Downlink, Uplink	Downlink	enum	
RefCh	reference channel selection indicator: CH_12.2k_MultiCode, CH_12.2k_SingleCode, CH_64k, CH_144k, CH_384k	CH_12.2k_MultiCode	enum	
PhyChNum_SA	physical channel allocation configuration	0 0 2 0 0 0 0	int array	[0, 16] for Downlink, [0,2] for Uplink
MaxPhyChNum	sum of allocated physical channel in all slots	2	int	[1, 112]
ModType_SA	type of modulation of all slots, 0 for QPSK, 1 for 8PSK	0 0 0 0 0 0 0	int array	{0, 1}
TFCI_SA	allocated TFCI transmitted active slots configuration	0 0 1 0 0 0 0	int array	{0, 1}
TFCI_Length_SA	length of TFCI of all slots	0 0 16 0 0 0 0	int array	{0, 4,8,16,32} for QPSK, {0,6,12,24,48} for 8PSK
SS_TPC_SA	type of SS and TPC of all slots	2 2 1 2 2 2 2	int array	{1, 2,3}

MinSF_PA	minimum spreading factor array corresponding to allocated physical channels	16 16	int array	{1, 16} for Downlink, {1,2,4,8,16} for Uplink
----------	---	-------	-----------	---

Pin Inputs

Pin	Name	Description	Signal Type
1	DataI	output data	multiple real
2	SizeInM	output data length	multiple int

Pin Outputs

Pin	Name	Description	Signal Type
3	DCH	DCH data out	int

Notes/Equations

- This subnetwork implements reference measurement channel. The schematic for this subnetwork is shown in the following figure.

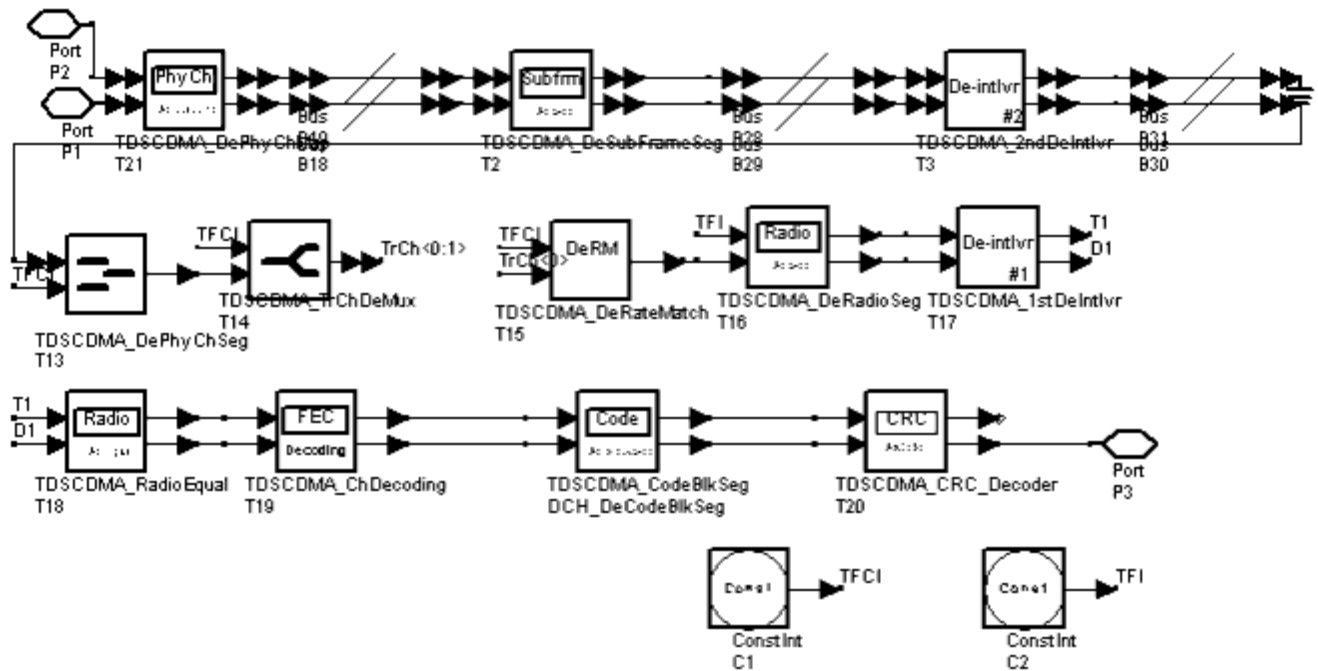

TDSCDMA_RefChDecoder Schematic

Advanced Design System 2008

2. MinSF_PA indicates the minimum spread factor that can be used for corresponding physical channel. The size of MinSF_PA must be equal to the sum of PhyChNum_SA elements.
3. SS_TPC_SA indicates the number of SS and TPC symbols transmitted in each slot. 1 denotes one SS and one TPC symbols are transmitted in the slot; 2 denotes no SS and no TPC symbols are transmitted in the slot; 3 denotes 16/SF SS and 16/SF TPC symbols are transmitted in the slot, where SF is the spreading factor of the physical channel used to transmitted SS and TPC symbols. Only the first allocated physical channel in each slot is used to transmit SS and TPC symbols.
4. The structure and settings for different data rates are given in the following tables.

12.2 kbps UL Reference Measurement Channel

Parameter	Value
Information data rate	12.2 kbps
RU's allocated	$1TS (1 \times SF8) = 2RU/5ms$
Midamble	144
Interleaving	20 ms
Power control	4 Bit/user/10ms
TFCI	16 Bit/user/10ms
4 Bit reserved for future use (place of SS)	4 Bit/user/10ms
Inband signalling DCCH	2.4 kbps
Puncturing level at Code rate 1/3: DCH / DCCH	33% / 33%

12.2 kbps UL and DL Multi-Code Reference Measurement Channel

Parameter	Value
Information data rate	12.2 kbps
RU's allocated	$1TS (2 \times SF16) = 2RU/5ms$
Midamble	144
Interleaving	20 ms
Power control (TPC)	4 Bit/user/10ms
TFCI	16 Bit/user/10ms
Synchronization Shift (SS)	4 Bit/user/10ms
Inband signalling DCCH	2.4 kbps
Puncturing level at Code rate 1/3: DCH / DCCH	33% / 33%

64 kbps UL Reference Measurement Channel

Parameter	Value
-----------	-------

Advanced Design System 2008

Information data rate	64 kbps
RU's allocated	1TS (1 × SF2) = 8RU/5ms
Midamble	144
Interleaving	20 ms
Power control (TPC)	4 Bit/user/10ms
TFCI	16 Bit/user/10ms
Synchronization Shift (SS)	4 Bit/user/10ms
Inband signalling DCCH	2.4 kbps
Puncturing level at Code rate: 1/3 DCH / ∫ DCCH	32% / 0

64 kbps DL Reference Measurement Channel

Parameter	Value
Information data rate	64 kbps
RU's allocated	1TS (8 × SF16) = 8RU/5ms
Midamble	144
Interleaving	20 ms
Power control (TPC)	4 Bit/user/10ms
TFCI	16 Bit/user/10ms
Synchronization Shift (SS)	4 Bit/user/10ms
Inband signalling DCCH	2.4 kbps
Puncturing level at Code rate: 1/3 DCH / ∫ DCCH	32% / 0

144 kbps UL Reference Measurement Channel

Parameter	Value
Information data rate	144 kbps
RU's allocated	2TS (1 × SF2) = 16RU/5ms
Midamble	144
Interleaving	20 ms
Power control (TPC)	8 Bit/user/10ms
TFCI	32 Bit/user/10ms
Synchronization Shift (SS)	8 Bit/user/10ms
Inband signalling DCCH	2.4 kbps

Advanced Design System 2008

Puncturing level at Code rate: 1/3 DCH / \int DCCH	38% / 7%
--	----------

144 kbps DL Reference Measurement Channel

Parameter	Value
Information data rate	144 kbps
RU's allocated	2TS (8 × SF16) = 16RU/5ms
Midamble	144
Interleaving	20 ms
Power control (TPC)	8 Bit/user/10ms
TFCI	32 Bit/user/10ms
Synchronization Shift (SS)	8 Bit/user/10ms
Inband signalling DCCH	2.4 kbps
Puncturing level at Code rate: 1/3 DCH / \int DCCH	38% / 7%

384 kbps UL Reference Measurement Channel

Parameter	Value
Information data rate	384 kbps
RU's allocated	4TS (1 × SF2 + 1 × SF8) = 40RU/5ms
Midamble	144
Interleaving	20 ms
Power control (TPC)	16 Bit/user/10ms
TFCI	64 Bit/user/10ms
Synchronization Shift (SS)	16 Bit/user/10ms
Inband signalling DCCH	max 2.0 kbps
Puncturing level at Code rate: 1/3 DCH / \int DCCH	41% / 12%

384 kbps DL Reference Measurement Channel

Parameter	Value
Information data rate	384 kbps
RU's allocated	4TS (10 × SF16) = 40RU/5ms
Midamble	144
Interleaving	20 ms

Advanced Design System 2008

Power control (TPC)	16 Bit/user/10ms
TFCI	64 Bit/user/10ms
Synchronization Shift (SS)	16 Bit/user/10ms
Inband signalling DCCH	max.2 kbps
Puncturing level at Code rate: 1/3 DCH / ∫ DCCH	41% / 12%

5. The configuration for transport channels is fixed when the parameter Link and RefCh are set. The configuration for physical channels can be set flexibly according to the previous tables. However, the settings for this subnetwork must match the settings of TDSCDMA_RefCh if it is used to transmit. An example for each configuration is shown in the following tables.

Physical Channel Setting of 12.2 kbps UL Reference Measurement Channel

Parameter	Value
Link	Uplink
RefCh	12.2K_SingleCode
PhyChNum_SA	0 0 1 0 0 0 0
MaxPhyChNum	1
ModType_SA	0[7]
TFCI_SA	0 0 1 0 0 0 0
TFCI_Length_SA	0 0 16 0 0 0 0
SS_TPC_SA	2 2 1 2 2 2 2
MinSF_PA	8

Physical Channel Setting of 12.2 kbps UL and DL Multi-Code Reference Measurement Channel

Parameter	Value
Link	Uplink for UL and Downlink for DL
RefCh	12.2K_MultiCode
PhyChNum_SA	0 0 2 0 0 0 0
MaxPhyChNum	2
ModType_SA	0[7]
TFCI_SA	0 0 1 0 0 0 0
TFCI_Length_SA	0 0 16 0 0 0 0
SS_TPC_SA	2 2 1 2 2 2 2
MinSF_PA	16[2]

Advanced Design System 2008

Physical Channel Setting 64 kbps UL Reference Measurement Channel

Parameter	Value
Link	Uplink
RefCh	64K
PhyChNum_SA	0 0 1 0 0 0 0
MaxPhyChNum	1
ModType_SA	0[7]
TFCI_SA	0 0 1 0 0 0 0
TFCI_Length_SA	0 0 16 0 0 0 0
SS_TPC_SA	2 2 1 2 2 2 2
MinSF_PA	2

Physical Channel Setting of 64 kbps DL Reference Measurement Channel

Parameter	Value
Link	Downlink
RefCh	64K
PhyChNum_SA	0 0 8 0 0 0 0
MaxPhyChNum	8
ModType_SA	0[7]
TFCI_SA	0 0 1 0 0 0 0
TFCI_Length_SA	0 0 16 0 0 0 0
SS_TPC_SA	2 2 1 2 2 2 2
MinSF_PA	16[8]

Physical Channel Setting of 144 kbps UL Reference Measurement Channel

Parameter	Value
Link	Uplink
RefCh	144K
PhyChNum_SA	0 0 1 1 0 0 0
MaxPhyChNum	2
ModType_SA	0[7]
TFCI_SA	0 0 1 1 0 0 0

Advanced Design System 2008

TFCI_Length_SA	0 0 16 16 0 0 0
SS_TPC_SA	2 2 1 1 2 2 2
MinSF_PA	2[2]

Physical Channel Setting of 144 kbps DL Reference Measurement Channel

Parameter	Value
Link	Downlink
RefCh	144K
PhyChNum_SA	0 0 8 8 0 0
MaxPhyChNum	16
ModType_SA	0[7]
TFCI_SA	0 0 1 1 0 0 0
TFCI_Length_SA	0 0 16 16 0 0 0
SS_TPC_SA	2 2 1 1 2 2 2
MinSF_PA	16[16]

Physical Channel Setting of 384 kbps UL Reference Measurement Channel

Parameter	Value
Link	Uplink
RefCh	384K
PhyChNum_SA	0 0 2 2 2 2 0
MaxPhyChNum	8
ModType_SA	0[7]
TFCI_SA	0 0 1 1 1 1 0
TFCI_Length_SA	0 0 16 16 16 16 0
SS_TPC_SA	2 2 1 1 1 1 2
MinSF_PA	8 2 8 2 8 2 8 2

Physical Channel Setting of 384 kbps DL Reference Measurement Channel

Parameter	Value
Link	Downlink
RefCh	384K

PhyChNum_SA	0 0 10 10 10 10 0
MaxPhyChNum	1
ModType_SA	0[7]
TFCI_SA	0 0 1 1 1 1 0
TFCI_Length_SA	0 0 16 16 16 16 0
SS_TPC_SA	2 2 1 1 1 1 2
MinSF_PA	16[40]

References

1. 3GPP Technical Specification TS 25.222 V4.4.0, Multiplexing and channel coding (TDD) Release 4.
2. 3GPP Technical Specification TS 25.102 V4.5.0, UE Radio Transmission and Reception (TDD) Release 4.
3. 3GPP Technical Specification TS 25.105 V4.5.0, BS Radio transmission and Reception (TDD) Release 4.

TDSCDMA_RM_Cal

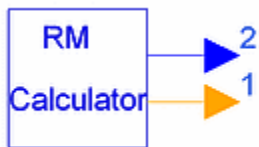

Description TDSCDMA RM calculator
 Library TDSCDMA, Multiplexing & Coding
 Class SDFTDSCDMA_RM_Cal

Parameters

Name	Description	Default	Type
TrChNum	number of Transport Channels	2	int
RadioFrameSize_TA	radio frame size array	402 90	int array
MatchedSize_TA	matched radio frame size array	268 60	int array

Pin Outputs

Pin	Name	Description	Signal Type
1	RM	rate match attributor	int
2	PL	puncture limit	real

Notes/Equations

1. This model is used to calculate the semi-static rate matching attribute for each transport channel and puncturing limit.
2. Each firing, 1 PL token and TrChNum RM tokens are produced, where TrChNum is the number of transport channels.
3. RadioFrameSize_TA specifies the frame size of each transport channel before rate match.
4. MatchedSize_TA specifies the frame size of each transport channel after rate match.

References

1. 3GPP Technical Specification TS 25.222 V4.4.0, Multiplexing and channel coding (TDD) Release 4.

TDSCDMA_SubFrameSeg



Description Subframe segmentation
 Library TDSCDMA, Multiplexing & Coding
 Class SDFTDSCDMA_SubFrameSeg
 Derived From TDSCDMA_CCTrCH_Base

Parameters

Name	Description	Default	Type	Range
PhyChNum_SA	physical channel allocation configuration	0 0 1 0 0 0 0	int array	[0, 2] for Uplink, [0, 16] for Downlink

Pin Inputs

Pin	Name	Description	Signal Type
1	DataI	input data	multiple int
2	SizeInM	input data length	multiple int

Pin Outputs

Pin	Name	Description	Signal Type
3	DataO	output data	multiple int

Notes/Equations

1. This model performs subframe segmentation on frames for each physical channel. Each firing, this model consumes $704 \times 3 \times 2$ tokens from each physical channel on multiple pin DataI, 1 token for each physical channel on multiple pin SizeInM, and exports $704 \times 3 \times 2$ tokens for each physical channel on multiple pin DataO.
2. PhyChNum_SA indicates the number of physical channels allocated in each time slot.
3. Each firing, one frame of data bits are consumed on DataI for each physical channel, which contains $704 \times 3 \times 2$ bits, the maximum number of data bits one frame can contain for one physical channel. The first part of frame are valid bits and the second are zero padding bits. The number of valid bits is specified by the token consumed on SizeInM. If the value of this token is $2 \times L$, the model divides the valid bits into two parts equally which has a length L each. The first L valid bits are exported with $(704 \times 3 - L)$ padding bits, which form the first subframe; the second L valid bits are then exported with $(704 \times 3 - L)$ padding bits, which form the second subframe.

References

1. 3GPP Technical Specification TS 25.222 V4.4.0, Multiplexing and channel coding (TDD) Release 4.

TDSCDMA_TFCI_Encoder



Description TFCI coding for 1.28Mcps TDD

Advanced Design System 2008

Library TDSCDMA, Multiplexing & Coding
Class SDFTDSCDMA_TFCI_Encoder

Parameters

Name	Description	Default	Type
TFCICoding	TFCI coding option: QPSK_RM_32_10, QPSK_RM_16_5, QPSK_RP_4, QPSK_RP_8, _8PSK_RM_48_10, _8PSK_RM_24_5, _8PSK_RP_6, _8PSK_RP_12	QPSK_RM_32_10	enum

Pin Inputs

Pin	Name	Description	Signal Type
1	TFCI	transport format combination indicator	int

Pin Outputs

Pin	Name	Description	Signal Type
2	TFCICode	coded TFCI	int
3	nTFCICodeWord	the number of bits in TFCI Code Word	int

Notes/Equations

- This model encodes TFCI bits into TFCI code words.
Each firing, 1 nTFCICodeWord token and nTFCICodeWord TFCICode tokens are produced when 1 TFCI tokens are consumed.
Encoding of the TFCI depends on the modulation method and length. The relationship between the TFCICoding options, input length and the output length are described in the following table.

TFCI Coding Options

TFCICoding	Input bits	nTFCICodeWord	Description of TFCI Encoding
QPSK_RP_4	1	4	If the number of TFCI bits is 1, then repetition will be

			used for coding. In this case each bit is repeated to a total of 4 times giving 4-bit transmission (NTFCI code word =4) for a single TFCI. For a single TFCI bit b0, the TFCI code word must be {b0, b0, b0, b0}.
QPSK_RP_8	2	8	If the number of TFCI bits is 2, then repetition will be used for coding. In this case each bit is repeated to a total of 4 times giving 8-bit transmission (NTFCI code word =8) for 2 TFCI bits. For two TFCI bits b0 and b1, the TFCI code word must be {b0, b1, b0, b1, b0, b1, b0, b1}.
QPSK_RM_16_5	3~5	16	If the number of TFCI bits is in the range 3~5, the TFCI is encoded using a (16, 5) bi-orthogonal (or first order Reed-Muller) code.
QPSK_RM_32_10	6~10	32	If the number of TFCI bits is in the range 6~10, the TFCI is encoded using a (32, 10) sub-code of the second order Reed-Muller code
_8PSK_RP_6	1	6	When the number of TFCI bits is 1, then repetition will be used for the coding. In this case, each bit is repeated to a total of 6 times giving 6-bit transmission (NTFCI code word = 6) for a single TFCI bit. For a single TFCI bit b0, the TFCI code word must be {b0, b0, b0, b0, b0, b0}.
_8PSK_RP_12	2	8	When the number of TFCI bits is 2, then repetition will be used for the coding.

			In this case, each bit is repeated to a total of 6 times giving 12-bit transmission (NTFCI code word = 12) for 2 TFCI bits. For two TFCI bits b0 and b1, the TFCI code word must be {b0, b1, b0, b1, b0, b1, b0, b1, b0, b1, b0, b1}.
_8PSK_RM_24_5	3~5	24	If the number of TFCI bits is in the range of 3 to 5, the TFCI bits are encoded using a (32,5) first order Reed-Muller code, then 8 bits out of 32 bits are punctured (Puncturing positions are 0, 1, 2, 3, 4, 5, 6, 7th bits).
_8PSK_RM_48_10	6~10	48	If the number of TFCI bits is in the range 6~10, the TFCI bits are encoded by using a (64,10) sub-code of the second order Reed-Muller code, then 16 bits out of 64 bits are punctured (Puncturing positions are 0, 4, 8, 13, 16, 20, 27, 31, 34, 38, 41, 44, 50, 54, 57, 61st bits).

References

1. 3GPP TS 25.222, 3rd Generation Partnership Project; Technical Specification Group Radio Access Network; Multiplexing and channel coding (TDD) (Release 4), version 4.3.0, Dec., 2001

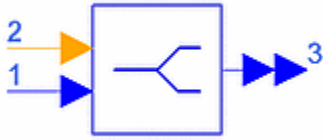

Description Transport channel demultiplexer
 Library TDSCDMA, Multiplexing & Coding
 Class SDFTDSCDMA_TrChDeMux
 Derived From TDSCDMA_CCTrCH_MuxBase

Parameters

Name	Description	Default	Type	Range
PhyChNum_SA	physical channel allocation configuration	0 0 1 0 0 0 0	int array	[0, 2] for Uplink, [0, 16] for Downlink
TrChNum	number of Transport Channels	2	int	[1, 32]
RM_TA	rate matching attributes of all Transport Channels	1 1	int array	[1, 256]
DynTF_Set_TA	dynamic part of TF set of all Transport Channels	100 100 244 244	int array	[0, 5000] for transport block size, [0, 20000] for transport block set size
TF_SetSize_TA	transport format set size of all Transport Channels	1 1	int array	[1, 64] for each element
TTI_TA	transmission time interval of all Transport Channels	2 1	int array	[0, 3] for each element
CRC_TA	number of CRC bits of all Transport Channels	2 3	int array	[0, 4] for each element
ChCodingType_TA	channel coding type of all Transport Channels	2 2	int array	[0, 3] for each element
PuncLimit	puncturing limit	2/3	real	(0, 1]
Link	link selection: Downlink, Uplink	Uplink	enum	

Advanced Design System 2008

ModType_SA	type of modulation of all slots, 0 for QPSK, 1 for 8PSK	0 0 0 0 0 0 0	int array	[0, 1] for each element
TFCI_SA	allocated TFCI transmitted active slots configuration	0 0 1 0 0 0 0	int array	[0, 1] for each element
TFCI_Length_SA	length of TFCI of all slots	0 0 16 0 0 0 0	int array	{0, 4, 8, 16, 32} for QPSK, {0, 6, 12, 24, 48} for 8PSK
SS_TPC_SA	type of SS and TPC of all slots	2 2 1 2 2 2 2	int array	[1, 3]
MinSF_PA	minimum spreading factor array corresponding to allocated physical channels	8	int array	{1, 2,4,8,16} for Uplink, {1,16} for Downlink
NdataOption	the two options to determine the number Ndata: Minimum, Autonomous	Minimum	enum	

Pin Inputs

Pin	Name	Description	Signal Type
1	DataIn	input data	real
2	TFCI	transport channel format combination indicator	int

Pin Outputs

Pin	Name	Description	Signal Type
3	DataOut	output data	multiple real

Notes/Equations

1. This model is used to perform transport channel demultiplexing, the inverse operation of transport channel multiplexing. Each firing, 1 token consumed at TFCI indicates the value of transport format combination indicator; $bm_PhyChNumAll \times MAX_BIT_SLOT$ tokens are consumed at DataIn, in which $bm_PhyChNumAll$ is the number of allocated physical channels and MAX_BIT_SLOT is the possible maximum number of bits in one physical channel, that is $704 \times 3 \times 2$; the maximum number of rate-matched tokens for all possible TFCI values

in one frame for each transport channel are exported at multiple pin DataOut.

- Each firing, one coded composite transport channel (CCTrCH) block is delivered to the transport channel demultiplexing. The CCTrCH block consists of frames from each transport channel serially and this model demultiplexes these frames.

The bits input to the transport channel demultiplexing are denoted by $s_1, s_2, s_3, \dots, s_S$, where S is the number of bits in a CCTrCH block. The bits output are denoted by $f_{i1}, f_{i2}, f_{i3}, \dots, f_{iV_i}$ where i is the transport channel number and V_i is the number of bits in the radio frame of transport channel i. The number of transport channels is denoted by I. $S = \sum_i V_i$. The transport channel Demultiplexing is defined as follows.

$$S_k = f_{1k} \quad k = 1, 2, \dots, V_1$$

$$S_k = f_{2, (k-V_1)} \quad k = V_1+1, V_1+2, \dots, V_1+V_2$$

$$S_k = f_{3, (k-(V_1+V_2))} \quad k = (V_1+V_2)+1, (V_1+V_2)+2, \dots, (V_1+V_2)+V_3$$

⋮
⋮
⋮

$$S_k = f_{I, (k-(V_1+V_2+\dots+V_{I-1}))}$$

$$k = (V_1+V_2+\dots+V_{I-1})+1, (V_1+V_2+\dots+V_{I-1})+2, \dots, (V_1+V_2+\dots+V_{I-1})+V_I$$

- All transport channel information must be provided in the form of arrays.

For DynTF_Set_TA the correct form is transport block size 1, transport block set size 1, transport block size 2, transport block set size 2, etc. The size of this array must be a multiple of 2, and the transport block set size must be a multiple of the relative transport block size.

When setting TTI_TA, CRC_TA and ChCodingType_TA, refer to the following table.

Array Values

TTI_TA		CRC_TA		ChCodingType_TA	
Time	Value	Coding	Value	Coding	Value
10ms	0	No CRC	0	No Coding	0
20ms	1	8 bits	1	1/2 CC	1
40ms	2	12 bits	2	1/3 CC	2
80ms	3	16 bits	3	1/3 TC	3
		24 bits	4		

CC = convolutional coding; TC = turbo coding

- PunLimit denotes the variable PL defined in [2]. Refer to [2] for details regarding use of this variable in rate matching algorithm.
- PhyChNum_SA indicates the number of allocated physical channels in each slot. The sum of PhyChNum_SA elements is the number of allocated physical channels.

6. TFCI_SA indicates in which slots TFCI bits will be transmitted. 0 denotes no TFCI bits will be transmitted in the slot. 1 denotes TFCI bits can be transmitted in the slot. The setting must be consistent with PhyChNum_SA setting, which means TFCI bits can only be transmitted in those slots in which the elements of PhyChNum_SA are not zero. Only the first allocated physical channel in each slot is used to transmit TFCI bits.
7. TFCI_Length_SA indicates the number of TFCI bits transmitted in each slot. If 0 is selected, the number of TFCI bits transmitted in the slot is dependent on the value of TFCI imported at TFCI pin. If a non-zero is selected, the number of TFCI bits transmitted in the slot is this non-zero value.
8. MinSF_PA indicates the minimum spread factor that can be used for corresponding physical channel. The size of MinSF_PA must be equal to the sum of PhyChNum_SA elements.
9. NdataOption specifies how the target number of rate-matched data is calculated with MinSF_PA. For Downlink, only Minimum can be selected. For Uplink, both can be selected. Refer to [2] for details.
10. SS_TPC_SA indicates the number of SS and TPC symbols transmitted in each slot. 1 denotes one SS and one TPC symbols are transmitted in the slot; 2 denotes no SS and no TPC symbols are transmitted in the slot; 3 denotes 16/SF SS and 16/SF TPC symbols are transmitted in the slot, where SF is the spreading factor of the physical channel used to transmitted SS and TPC symbols. Only the first allocated physical channel in each slot is used to transmit SS and TPC symbols.

References

1. 3GPP Technical Specification TS 25.221 V4.5.0, Physical channels and mapping of transport channels (TDD) Release 4.
2. 3GPP Technical Specification TS 25.222 V4.4.0, Multiplexing and channel coding (TDD) Release 4.
3. 3GPP Technical Specification TS 25.223 V4.4.0, Spreading and modulation (TDD) Release 4.
4. 3GPP Technical Specification TS 25.224 V4.5.0, Physical layer procedures (TDD) 4.

TDSCDMA_TrChMux

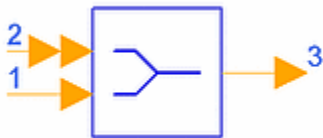

Description Transport channel multiplexer
Library TDSCDMA, Multiplexing & Coding
Class SDFTDSCDMA_TrChMux
Derived From TDSCDMA_CCTrCH_MuxBase

Parameters

Advanced Design System 2008

Name	Description	Default	Type	Range
PhyChNum_SA	physical channel allocation configuration	0 0 1 0 0 0 0	int array	[0, 2] for Uplink, [0, 16] for Downlink
TrChNum	number of Transport Channels	2	int	[1, 32]
RM_TA	rate matching attributes of all Transport Channels	1 1	int array	[1, 256]
DynTF_Set_TA	dynamic part of TF set of all Transport Channels	100 100 244 244	int array	[0, 5000] for transport block size, [0, 20000] for transport block set size
TF_SetSize_TA	transport format set size of all Transport Channels	1 1	int array	[1, 64] for each element
TTI_TA	transmission time interval of all Transport Channels	2 1	int array	[0, 3] for each element
CRC_TA	number of CRC bits of all Transport Channels	2 3	int array	[0, 4] for each element
ChCodingType_TA	channel coding type of all Transport Channels	2 2	int array	[0, 3] for each element
PuncLimit	puncturing limit	2/3	real	(0, 1]
Link	link selection: Downlink, Uplink	Uplink	enum	
ModType_SA	type of modulation of all slots, 0 for QPSK, 1 for 8PSK	0 0 0 0 0 0 0	int array	[0, 1] for each element
TFCI_SA	allocated TFCI transmitted active slots configuration	0 0 1 0 0 0 0	int array	[0, 1] for each element
TFCI_Length_SA	length of TFCI of all slots	0 0 16 0 0 0 0	int array	{0, 4, 8, 16, 32} for QPSK, {0, 6, 12, 24, 48} for 8PSK
SS_TPC_SA	type of SS and TPC of all slots	2 2 1 2 2 2 2	int array	[1, 3]
MinSF_PA	minimum spreading	8	int array	{1, 2,4,8,16} for

	factor array corresponding to allocated physical channels			Uplink, {1,16} for Downlink
NdataOption	the two options to determine the number Ndata: Minimum, Autonomous	Minimum	enum	

Pin Inputs

Pin	Name	Description	Signal Type
1	TFCI	transport channel format combination indicator	int
2	DataIn	input data	multiple int

Pin Outputs

Pin	Name	Description	Signal Type
3	DataOut	output data	int

Notes/Equations

1. This model is used to perform transport channel multiplexing. Each firing, 1 token consumed at TFCI indicates the value of transport format combination indicator; the maximum number of rate-matched tokens for all possible TFCI values in one frame for each transport channel are consumed at multiple pin DataIn; $bm_PhyChNumAll \times MAX_BIT_SLOT$ tokens are exported at DataOut, in which $bm_PhyChNumAll$ is the number of allocated physical channels and MAX_BIT_SLOT is the possible maximum number of bits in one physical channel, that is $704 \times 3 \times 2$.
2. Every 10 msec, one radio frame from each transport channel is delivered to the transport channel multiplexing. These radio frames are serially multiplexed into a coded composite transport channel (CCTrCH). The bits input to the transport channel multiplexing are denoted by $f_{i1}, f_{i2}, f_{i3}, \dots, f_{iV_i}$, where i is the transport channel number and V_i is the number of bits in the radio frame of transport channel i . The number of transport channels is denoted by I . The bits output from transport channel multiplexing are denoted by $s_1, s_2, s_3, \dots, s_S$, where S is the number of bits, i.e. $S = \sum_i V_i$. The transport channel multiplexing is defined as:

$$S_k = f_{1k} \quad k = 1, 2, \dots, V_1$$

$$S_k = f_{2, (k - V_1)} \quad k = V_1 + 1, V_1 + 2, \dots, V_1 + V_2$$

$$S_k = f_{3, (k - (V_1 + V_2))} \quad k = (V_1 + V_2) + 1, (V_1 + V_2) + 2, \dots, (V_1 + V_2) + V_3$$

·
·
·

$$S_k = f_{I, (k - (V_1 + V_2 + \dots + V_{I-1}))}$$

$$k = (V_1 + V_2 + \dots + V_{I-1}) + 1, (V_1 + V_2 + \dots + V_{I-1}) + 2, \dots, (V_1 + V_2 + \dots + V_{I-1}) + V_I$$

3. All transport channel information must be provided in the form of arrays.

For DynTF_Set_TA the correct form is transport block size 1, transport block set size 1, transport block size 2, transport block set size 2, etc. The size of this array must be a multiple of 2, and the transport block set size must be a multiple of the relative transport block size.

When setting TTI_TA, CRC_TA and ChCodingType_TA, refer to the following table.

Array Values

TTI_TA		CRC_TA		ChCodingType_TA	
Time	Value	Coding	Value	Coding	Value
10ms	0	No CRC	0	No Coding	0
20ms	1	8 bits	1	1/2 CC	1
40ms	2	12 bits	2	1/3 CC	2
80ms	3	16 bits	3	1/3 TC	3
		24 bits	4		

CC = convolutional coding; TC = turbo coding

4. Punclimit denotes the variable PL defined in [2]. Refer to [2] for details regarding use of this variable in rate matching algorithm.
5. PhyChNum_SA indicates the number of allocated physical channels in each slot. The sum of PhyChNum_SA elements is the number of allocated physical channels.
6. TFCI_SA indicates in which slots TFCI bits will be transmitted. 0 denotes no TFCI bits will be transmitted in the slot. 1 denotes TFCI bits can be transmitted in the slot. The setting must be consistent with PhyChNum_SA setting, which means TFCI bits can only be transmitted in those slots in which the elements of PhyChNum_SA are not zero. Only the first allocated physical channel in each slot is used to transmit TFCI bits.
7. TFCI_Length_SA indicates the number of TFCI bits transmitted in each slot. If 0 is selected, the number of TFCI bits transmitted in the slot is dependent on the value of TFCI imported at TFCI pin. If a non-zero is selected, the number of TFCI bits transmitted in the slot is this non-zero value.
8. MinSF_PA indicates the minimum spread factor that can be used for corresponding physical channel. The size of MinSF_PA must be equal to the sum of PhyChNum_SA elements.
9. NdataOption specifies how the target number of rate-matched data is calculated with MinSF_PA. For Downlink, only Minimum can be selected. For Uplink, both can be selected. Refer to [2] for details.
10. SS_TPC_SA indicates the number of SS and TPC symbols transmitted in each slot. 1 denotes one SS and one TPC symbols are transmitted in the slot; 2 denotes no SS and no TPC symbols are transmitted in the slot; 3 denotes 16/SF SS and 16/SF TPC symbols are transmitted in the slot, where SF is the spreading factor of the

physical channel used to transmitted SS and TPC symbols. Only the first allocated physical channel in each slot is used to transmit SS and TPC symbols.

References

1. 3GPP Technical Specification TS 25.221 V4.5.0, Physical channels and mapping of transport channels (TDD) Release 4.
2. 3GPP Technical Specification TS 25.222 V4.4.0, Multiplexing and channel coding (TDD) Release 4.
3. 3GPP Technical Specification TS 25.223 V4.4.0, Spreading and modulation (TDD) Release 4.
4. 3GPP Technical Specification TS 25.224 V4.5.0, Physical layer procedures (TDD) Release 4.

Physical Channel Components

TDSCDMA_DPCH



Description Dedicated physical channel
 Library TDSCDMA, Physical Channels
 Class SDFTDSCDMA_DPCH

Parameters

Name	Description	Default	Type	Range
SlotIndex	index of slot	2	int	[0, 6]
MidambleAllocScheme	midamble allocation scheme: UE_Specific, Common, Default	Default	enum	
BasicMidambleID	index of basic	0	int	[0, 127]

Advanced Design System 2008

	midamble			
K	maximum number of midamble shifts in a cell	16	int	{2, 4,6,8,10,12,14,16}
MidambleID	index of midamble	1	int	[1, K]
SpreadFactor	spreading factor	16	int	{1, 2,4,8,16} †
SpreadCode	index of spread code	1	int	[1, SpreadFactor]
PhyChNum	number of channelization codes used in a timeslot	1	int	[1, 16]
Link	link selection: Downlink, Uplink	Downlink	enum	
ModType	type of modulation: QPSK, _8PSK	QPSK	enum	
N_TFCI	number of TFCI bits	0	int	†
N_SS_N_TPC	number of SS and TPC	0	int	†
† N_TFCI, and N_SS_N_TPC values are given in Note 3.				

Pin Inputs

Pin	Name	Description	Signal Type
1	Data	data of dedicated physical channel	int
2	TFCI	transport format combination indicator bits	int
3	SS	information bits for uplink synchronization control	int
4	TPC	transmit power control bits	int

Pin Outputs

Pin	Name	Description	Signal Type
5	Output	data other than midamble in DPCH	complex

Notes/Equations

- This subnetwork generates dedicated physical channel signals. The schematic for this subnetwork is shown in the following figure. TDSCDMA_DPCH_DataMux multiplexes data, TFCI, SS and TPC bits. Data is then modulated and spread, then multiplexed with midamble and GP. The burst is placed in one subframe of slot according to the SlotIndex setting. Data other than slot will be all 0.

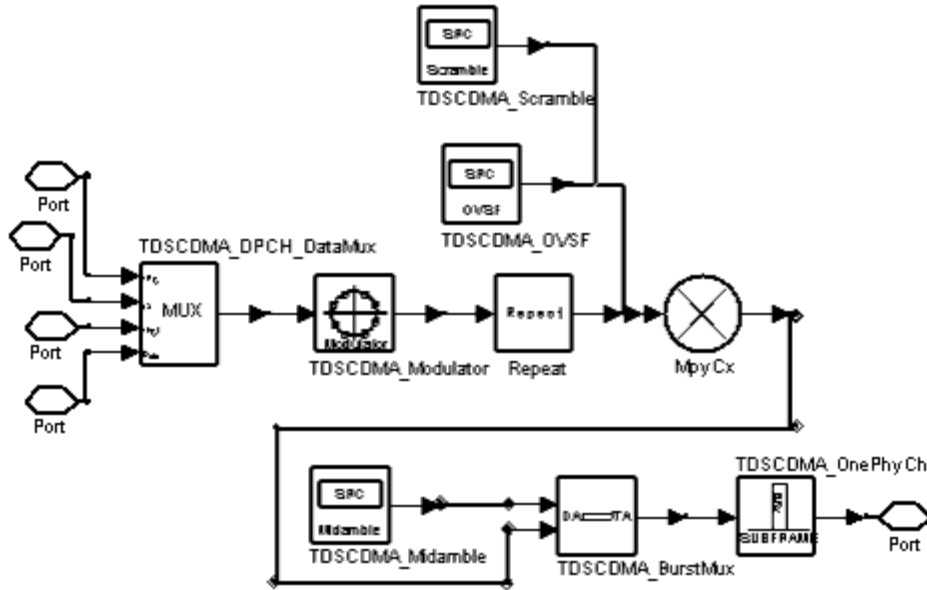

TDSCDMA_DPCH Schematic

- Sub-frame and burst structure are illustrated in the following figures. Where Time slot #n (n = 0 to 6) is the nth traffic time slot, 864-chip duration; DwPTS is downlink pilot time slot, 96-chip duration; UpPTS is uplink pilot time slot, 160-chip duration; GP is main guard period for TDD operation, 96-chip duration.

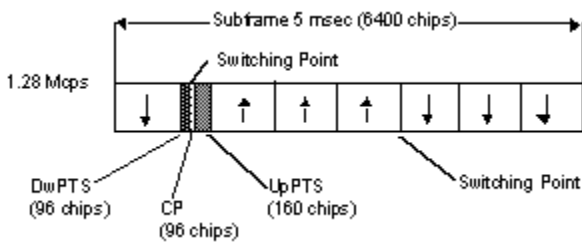

Sub-Frame Structure for 1.28Mcps TDD Option

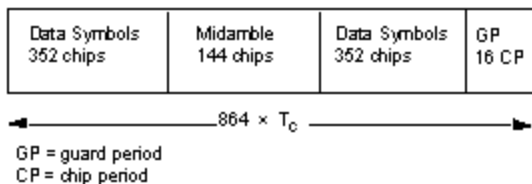

Burst Structure of Traffic Burst Format

- Time slot formats for downlink and uplink with QPSK modulation are given in the next two tables; time slot

Advanced Design System 2008

formats for both links with 8PSK modulation are given in the third table.

Time Slot Formats for Downlink with QPSK Modulation

Slot Format	Spread Factor	NTFCI Code Word (bits)	NSS and NTPC (bits)
0	16	0	0 and 0
1	16	4	0 and 0
2	16	8	0 and 0
3	16	16	0 and 0
4	16	32	0 and 0
5	16	0	2 and 2
6	16	4	2 and 2
7	16	8	2 and 2
8	16	16	2 and 2
9	16	32	2 and 2
10	1	0	0 and 0
11	1	4	0 and 0
12	1	8	0 and 0
13	1	16	0 and 0
14	1	32	0 and 0
15	1	0	2 and 2
16	1	4	2 and 2
17	1	8	2 and 2
18	1	16	2 and 2
19	1	32	2 and 2
20	1	0	32 and 32
21	1	4	32 and 32
22	1	8	32 and 32
23	1	16	32 and 32
24	1	32	32 and 32

Time Slot Formats for Uplink with QPSK Modulation

Slot Format	Spread Factor	NTFCI Code Word (bits)	NSS and NTPC (bits)
0	16	0	0 and 0

Advanced Design System 2008

1	16	4	0 and 0
2	16	8	0 and 0
3	16	16	0 and 0
4	16	32	0 and 0
5	16	0	2 and 2
6	16	4	2 and 2
7	16	8	2 and 2
8	16	16	2 and 2
9	16	32	2 and 2
10	8	0	0 and 0
11	8	4	0 and 0
12	8	8	0 and 0
13	8	16	0 and 0
14	8	32	0 and 0
15	8	0	2 and 2
16	8	4	2 and 2
17	8	8	2 and 2
18	8	16	2 and 2
19	8	32	2 and 2
20	8	0	4 and 4
21	8	4	4 and 4
22	8	8	4 and 4
23	8	16	4 and 4
24	8	32	4 and 4
25	4	0	0 and 0
26	4	4	0 and 0
27	4	8	0 and 0
28	4	16	0 and 0
29	4	32	0 and 0
30	4	0	2 and 2
31	4	4	2 and 2
32	4	8	2 and 2

Advanced Design System 2008

33	4	16	2 and 2
34	4	32	2 and 2
35	4	0	8 and 8
36	4	4	8 and 8
37	4	8	8 and 8
38	4	16	8 and 8
39	4	32	8 and 8
40	2	0	0 and 0
41	2	4	0 and 0
42	2	8	0 and 0
43	2	16	0 and 0
44	2	32	0 and 0
45	2	0	2 and 2
46	2	4	2 and 2
47	2	8	2 and 2
48	2	16	2 and 2
49	2	32	2 and 2
50	2	0	16 and 16
51	2	4	16 and 16
52	2	8	16 and 16
53	2	16	16 and 16
54	2	32	16 and 16
55	1	0	0 and 0
56	1	4	0 and 0
57	1	8	0 and 0
58	1	16	0 and 0
59	1	32	0 and 0
60	1	0	2 and 2
61	1	4	2 and 2
62	1	8	2 and 2
63	1	16	2 and 2
64	1	32	2 and 2

Advanced Design System 2008

65	1	0	32 and 32
66	1	4	32 and 32
67	1	8	32 and 32
68	1	16	32 and 32
69	1	32	32 and 32

Time Slot Formats for 8PSK modulation

Slot Format	Spread Factor	NTFCI Code Word (bits)	NSS and NTPC (bits)
0	1	0	0 and 0
1	1	6	0 and 0
2	1	12	0 and 0
3	1	24	0 and 0
4	1	48	0 and 0
5	1	0	3 and 3
6	1	6	3 and 3
7	1	12	3 and 3
8	1	24	3 and 3
9	1	48	3 and 3
10	1	0	48 and 48
11	1	6	48 and 48
12	1	12	48 and 48
13	1	24	48 and 48
14	1	48	48 and 48
15	16	0	0 and 0
16	16	6	0 and 0
17	16	12	0 and 0
18	16	24	0 and 0
19	16	48	0 and 0
20	16	0	3 and 3
21	16	6	3 and 3
22	16	12	3 and 3
23	16	24	3 and 3

24	16	48	3 and 3
----	----	----	---------

References

1. 3GPP TS 25.221, 3rd Generation Partnership Project; Technical Specification Group Radio Access Network; Physical channels and mapping of transport channels onto physical channels (TDD) (Release 4), version 4.3.0, Dec., 2001.

TDSCDMA_DwPCH



Description Downlink sychronization channel generation
 Library TDSCDMA, Physical Channels
 Class SDFTDSCDMA_DwPCH

Parameters

Name	Description	Default	Type	Range
SyncCode	index of basic synchronization code	0	int	[0, 31]
ModPhase	type of modulation quadruples: S1, S2	S1	enum	

Pin Outputs

Pin	Name	Description	Signal Type
1	output	downlink sync code output	complex

Notes/Equations

1. This model generates downlink synchronization channel signals.

The schematic for this subnetwork is shown in the following figure.

Each firing, one sub-frame containing 6400 chips is exported. The downlink synchronization sequence containing 64 chips is exported at location 897 ~ 960. Data at other locations are 0s.

- Four consecutive phases of the downlink synchronization sequence are used to indicate the presence of the P-CCPCH in the next 4 sub-frames. If ModPhase=S1, there is a P-CCPCH in the next 4 sub-frames; if ModPhase=S2, there is no P-CCPCH in the next 4 sub-frames.

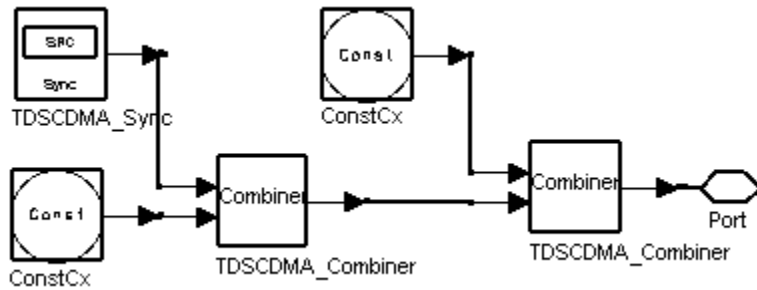

TDSCDMA_DwPCH Schematic

References

- 3GPP TS 25.223, 3rd Generation Partnership Project; Technical Specification Group Radio Access Network; Spreading and modulation (TDD) (Release 4), version 4.3.0, Dec., 2001.

TDSCDMA_FPACH



Description Fast physical access channel
 Library TDSCDMA, Physical Channels
 Class SDFTDSCDMA_FPACH

Parameters

Name	Description	Default	Type	Range
MidambleAllocScheme	midamble allocation scheme: UE_Specific,	Default	enum	

	Common, Default			
BasicMidambleID	index of basic midamble	0	int	[0, 127]
K	maximum number of midamble shifts in a cell	16	int	{2, 4,6,8,10,12,14,16}
MidambleID	index of midamble	1	int	[1, K]
SpreadCode	index of spread code	2	int	[1, 16]
PhyChNum	number of channelization codes used in a timeslot	1	int	[1, 16]
ModType	type of modulation: QPSK, _8PSK	QPSK	enum	

Pin Inputs

Pin	Name	Description	Signal Type
1	Input	Input data for FPACH	int

Pin Outputs

Pin	Name	Description	Signal Type
2	Output	output data	complex

Notes/Equations

1. This subnetwork generates fast physical access channel signals. The FPACH is used by Node B to carry, in a single burst, the detected signature with timing and power level adjustment indicator to the user equipment. FPACH uses one code with spreading factor of 16, so that its burst is composed of 44 symbols. The spreading code, training sequence, and time slot position are configured by the network and signalled on the BCH. The schematic for this subnetwork is shown in the following figure.

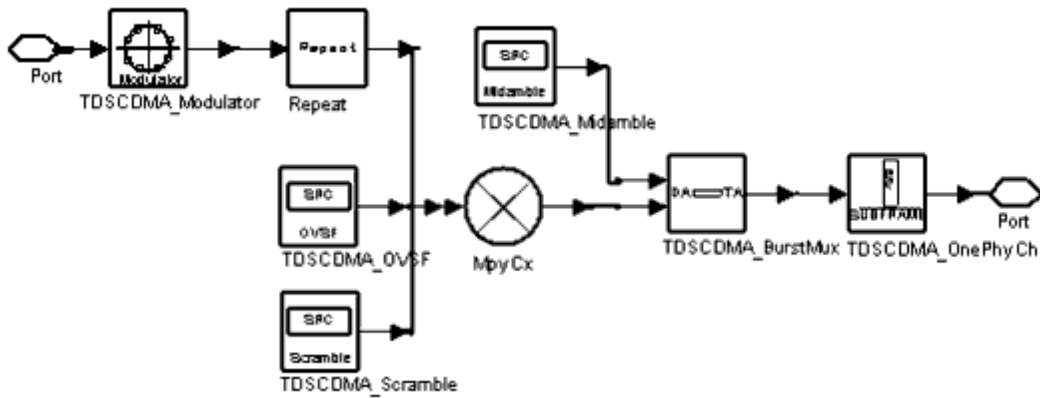

TDSCDMA_FPACH Schematic

References

1. 3GPP TS 25.221, 3rd Generation Partnership Project; Technical Specification Group Radio Access Network; Physical channels and mapping of transport channels onto physical channels (TDD) (Release 4), version 4.3.0.

TDSCDMA_PCCPCH



Description Primary common control channel
 Library TDSCDMA, Physical Channels
 Class SFTDSCDMA_PCCPCH

Parameters

Name	Description	Default	Type	Range
BasicMidambleID	index of basic midamble	0	int	[0, 127]
SCTD	Space code transmit diversity flag: ON,	OFF	enum	

Advanced Design System 2008

	OFF			
ModType	type of modulation: QPSK, _8PSK	QPSK	enum	

Pin Inputs

Pin	Name	Description	Signal Type
1	Input1	Input data for P-CCPCH1	int
2	Input2	Input data for P-CCPCH2	int

Pin Outputs

Pin	Name	Description	Signal Type
3	Output	output data	complex

Notes/Equations

- This subnetwork generates primary common control physical channel signals. The schematic for this subnetwork is shown in the following figure.
- P-CCPCHs are mapped onto the first two code channels of timeslot 0. The P-CCPCH is always transmitted with an antenna pattern configuration that provides whole cell coverage. The P-CCPCH uses fixed spreading with a spreading factor SF = 16. P-CCPCH1 and P-CCPCH2 always use first and second channelization codes, respectively. The training sequences (midambles) are used for the P-CCPCH. For timeslot 0 in which the P-CCPCH is transmitted, midambles $\underline{m}(1)$ and $\underline{m}(2)$ are reserved for P-CCPCH in order to support Space Code Transmit Diversity (SCTD) and the beacon function. The use of midambles depends on whether SCTD is applied to the P-CCPCH. If antenna diversity is not applied to P-CCPCH, $\underline{m}(1)$ is used and $\underline{m}(2)$ is left unused. Otherwise, $\underline{m}(1)$ is used for the first antenna and $\underline{m}(2)$ is used for the diversity antenna.

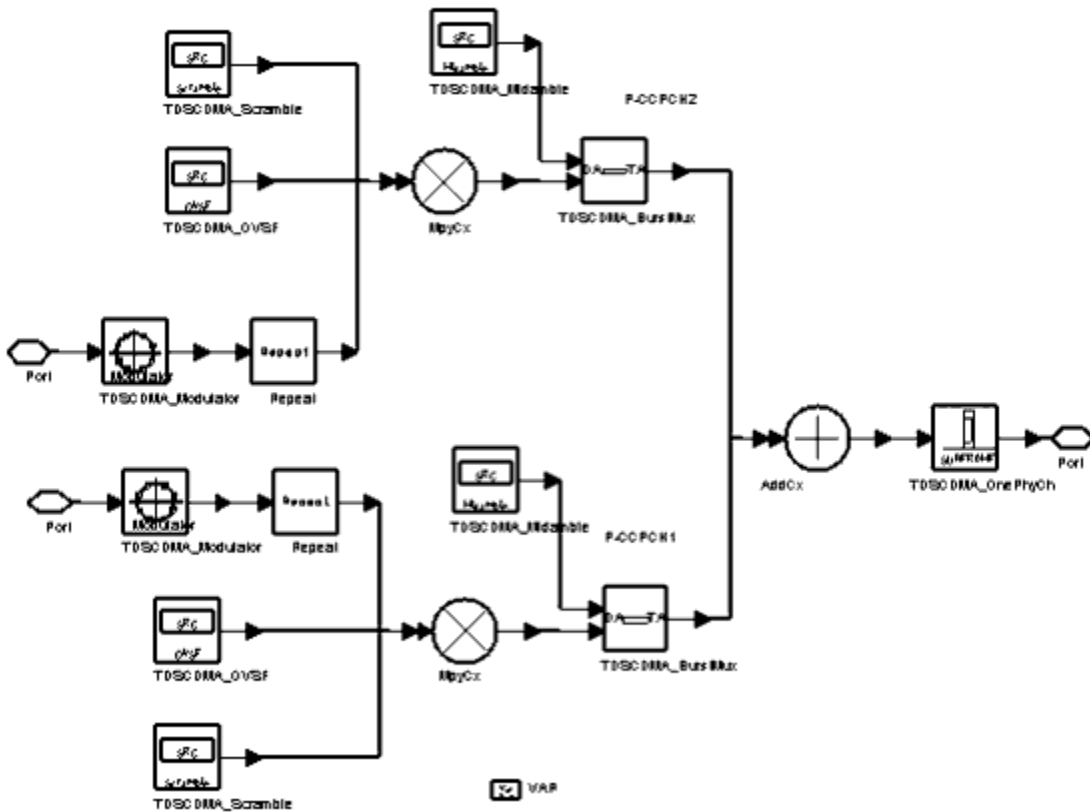

TDSCDMA_PCCPCH Schematic

References

1. 3GPP TS 25.221, 3rd Generation Partnership Project; Technical Specification Group Radio Access Network; Physical channels and mapping of transport channels onto physical channels (TDD) (Release 4), version 4.3.0.

TDSCDMA_PICH



Description Page indicator channel

Advanced Design System 2008

Library TDSCDMA, Physical Channels
Class SDFTDSCDMA_PICH

Name	Description	Default	Type	Range
SlotIndex	index of slot	6	int	{0, 2,3,4,5,6}
MidambleAllocScheme	midamble allocation scheme: UE_Specific, Common, Default	Default	enum	
BasicMidambleID	index of basic midamble	0	int	[0, 127]
K	maximum number of midamble shifts in a cell	16	int	{2, 4,6,8,10,12,14,16}
MidambleID1	index of midamble for S-CCPCH1	5	int	[1, K]
MidambleID2	index of midamble for S-CCPCH2	6	int	[1, K]
SpreadCode1	index of spread code for S-CCPCH1	5	int	[1, 16]
SpreadCode2	index of spread code for S-CCPCH2	6	int	[1, 16]
PhyChNum	number of channelization codes used in a timeslot	2	int	[1, 16]
ModType	type of modulation: QPSK, _8PSK	QPSK	enum	

Pin	Name	Description	Signal Type
1	Input	Input data	int

Pin	Name	Description	Signal Type
2	Output	output data	complex

Notes/Equations

- This subnetwork generates page indicator channel signals.
The schematic for this subnetwork is shown in the following figures.

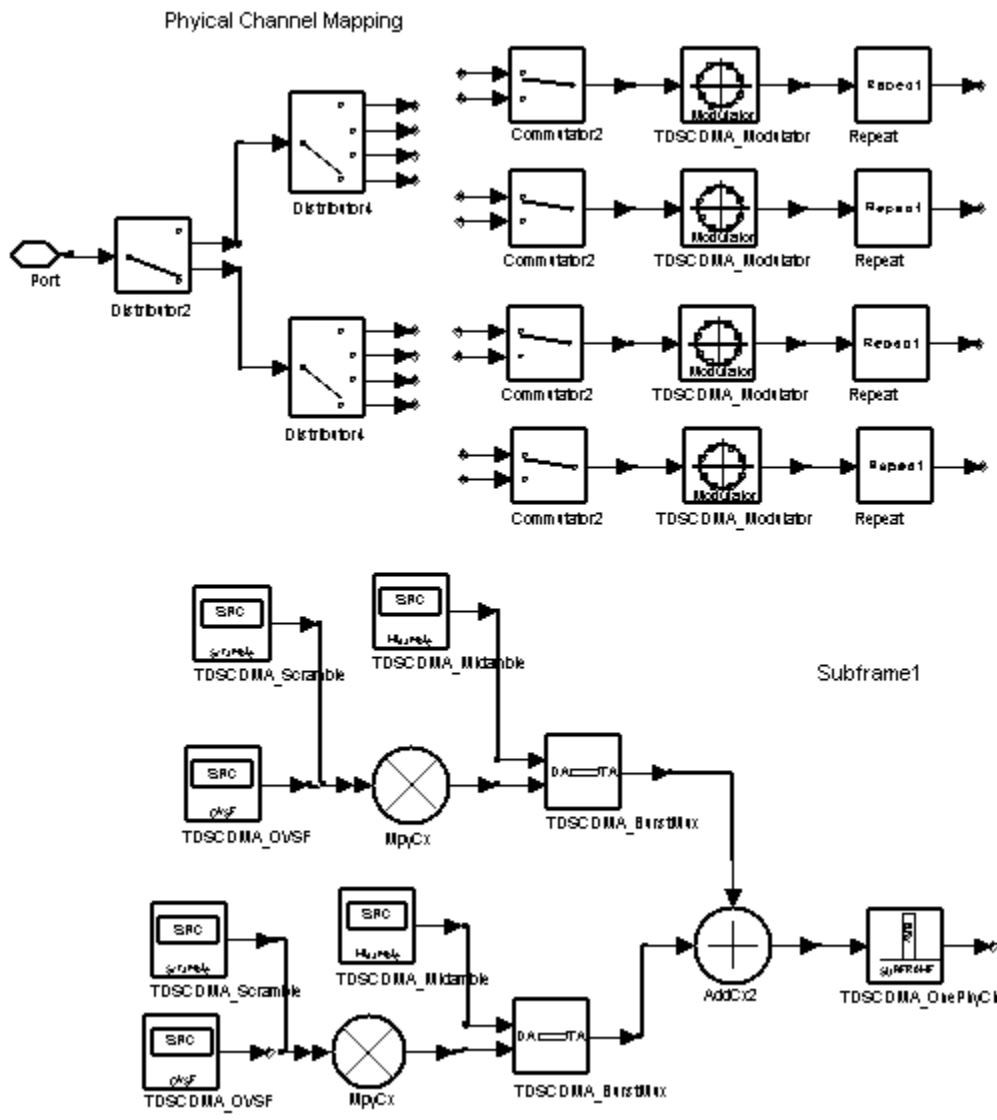

TDSCDMA_PICH Schematic (1 of 2)

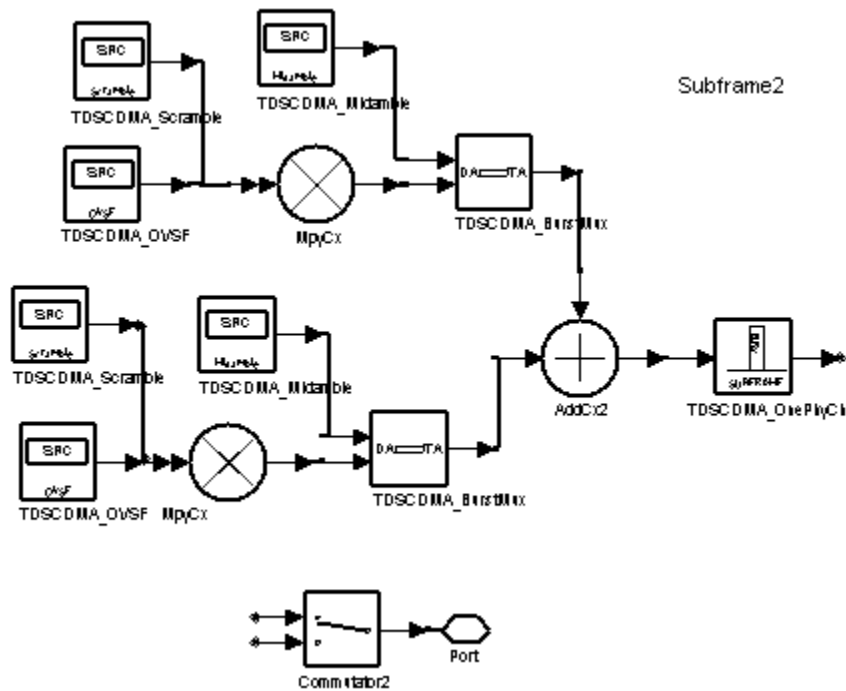

TDSCDMA_PICH Schematic (2 of 2)

- The following figure illustrates the structure of a PICH transmission and the numbering of bits within the bursts. NPIB bits are used to carry the paging indicators, where NPIB=352. The PICH uses fixed spreading with a spreading factor SF = 16.

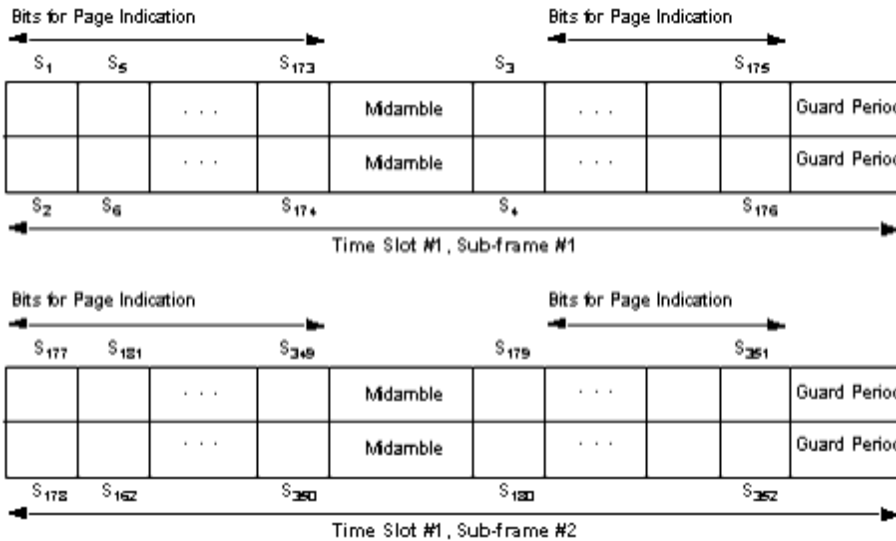

Transmission of Paging Indicator Carrying Bits in PICH Bursts

References

1. 3GPP TS 25.221, 3rd Generation Partnership Project; Technical Specification Group Radio Access Network; Physical channels and mapping of transport channels onto physical channels (TDD) (Release 4) , version 4.3.0.

TDSCDMA_PRACH



Description Physical random access channel
 Library TDSCDMA, Physical Channels
 Class SDFTDSCDMA_PRACH

Parameters

Name	Description	Default	Type	Range
SlotIndex	index of slot	1	int	[0, 6]
MidambleAllocScheme	midamble allocation scheme: UE_Specific, Common, Default	Default	enum	
BasicMidambleID	index of basic midamble	0	int	[0, 127]
K	maximum number of midamble shifts in a cell	16	int	{2, 4,6,8,10,12,14,16}
MidambleID	index of midamble	1	int	[1, K]
SpreadFactor	spreading factor	16	int	{4, 8,16}
SpreadCode	index of spread code	1	int	[1, SpreadFactor]
PhyChNum	number of channelization codes used in a timeslot	1	int	[1, 16]

Pin Inputs

Pin	Name	Description	Signal Type
-----	------	-------------	-------------

Advanced Design System 2008

1	Data	data of physical random access channel	int
---	------	--	-----

Pin Outputs

Pin	Name	Description	Signal Type
2	Output	data other than midamble in PRACH	complex

Notes/Equations

- This subnetwork generates physical random access channel data. Each firing, for QPSK, 864 Output tokens are produced when $1408/\text{SpreadFactor}$ Data tokens are consumed. For 8PSK, 864 Output tokens are produced when $2112/\text{SpreadFactor}$ Data tokens are consumed. The schematic for this subnetwork is shown in the following figure.

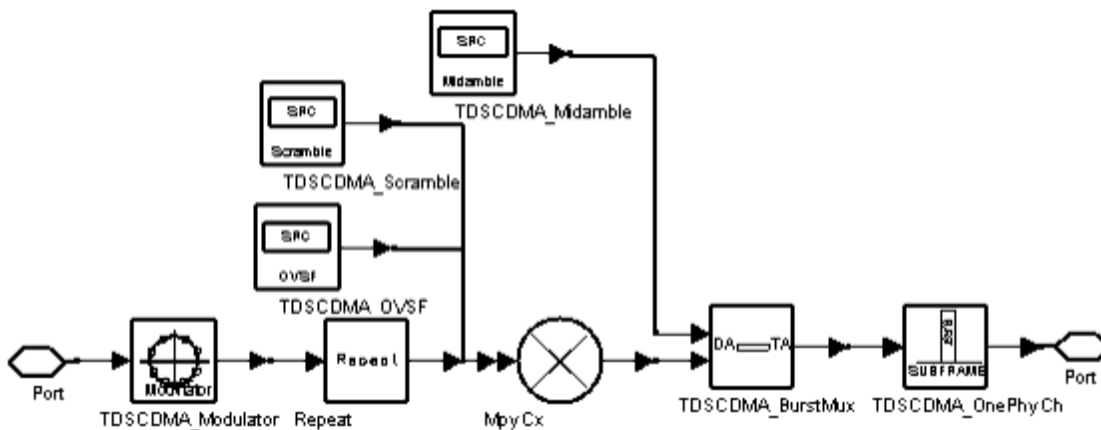

TDSCDMA_PRACH Schematic

References

- 3GPP TS 25.221, 3rd Generation Partnership Project; Technical Specification Group Radio Access Network; Physical channels and mapping of transport channels onto physical channels (TDD) (Release 4), version 4.3.0, Dec., 2001.

TDSCDMA_PSCH



Description Uplink/downlink physical shared channel
 Library TDSCDMA, Physical Channels
 Class SDFTDSCDMA_PSCH

Parameters

Name	Description	Default	Type	Range
SlotIndex	index of slot	2	int	[0, 6]
MidambleAllocScheme	midamble allocation scheme: UE_Specific, Common, Default	Default	enum	
BasicMidambleID	index of basic midamble	0	int	[0, 127]
K	maximum number of midamble shifts in a cell	16	int	{2, 4,6,8,10,12,14,16}
MidambleID	index of midamble	1	int	[1, K]
SpreadFactor	spreading factor	16	int	{1, 16} for downlink; {1,2,4,8,16} for uplink
SpreadCode	index of spreading code	1	int	[1, SpreadFactor]
PhyChNum	number of channelization codes used in a timeslot	1	int	[1, 16]
Link	link selection: Downlink, Uplink	Downlink	enum	
ModType	type of modulation: QPSK, _8PSK	QPSK	enum	
N_TFCI	number of TFCI bits	0	int	{0, 4, 8, 16, 32} for QPSK; {0, 6, 12, 24, 48} for 8PSK

Pin Inputs

Pin	Name	Description	Signal Type
1	Data	data of physical shared channel	int
2	TFCI	transport format combination indicator bits	int

Pin Outputs

Pin	Name	Description	Signal Type
3	Output	data other than midamble in PSCH	complex

Notes/Equations

1. This subnetwork generates physical downlink/uplink shared channel data. The schematic for this subnetwork is shown in the following figure.

Each firing:

- for QPSK, 864 Output tokens are produced when $(1408/\text{SpreadFactor}-N_{\text{TFCI}}/2)$ Data tokens and $N_{\text{TFCI}}/2$ TFCI tokens are consumed;
- for 8PSK, 864 Output tokens are produced when $(2112/\text{SpreadFactor}-N_{\text{TFCI}}/2)$ Data tokens and $N_{\text{TFCI}}/2$ TFCI tokens are consumed.

Physical downlink/uplink shared channel provides for transmission of TFCI.

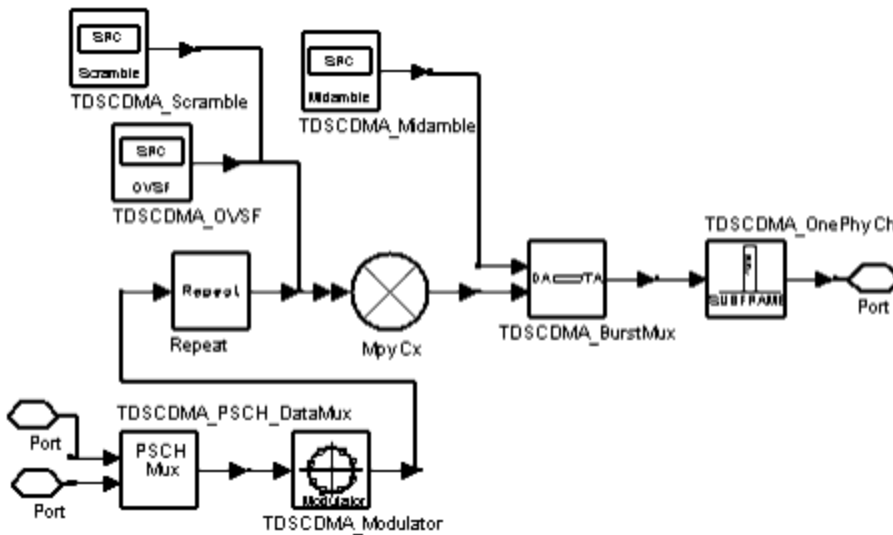

TDSCDMA_PSCH Schematic

References

1. 3GPP TS 25.221, 3rd Generation Partnership Project; Technical Specification Group Radio Access Network; Physical channels and mapping of transport channels onto physical channels (TDD) (Release 4), version 4.3.0, Dec., 2001.

TDSCDMA_SCCPCH



Description Secondary common control channel
 Library TDSCDMA, Physical Channels
 Class SDFTDSCDMA_SCCPCH

Parameters

Name	Description	Default	Type	Range
SlotIndex	index of slot	6	int	{0, 2,3,4,5,6}
MidambleAllocScheme	midamble allocation scheme: UE_Specific, Common, Default	Default	enum	
BasicMidambleID	index of basic midamble	0	int	[0, 127]
K	maximum number of midamble shifts in a cell	16	int	{2, 4,6,8,10,12,14,16}
MidambleID1	index of midamble for S-CCPCH1	2	int	[1, K]
MidambleID2	index of midamble for S-CCPCH2	3	int	[1, K]
SpreadCode1	index of spread code for S-CCPCH1	2	int	[1, 16]
SpreadCode2	index of spread code for S-CCPCH2	3	int	[1, 16]
PhyChNum	number of	2	int	[1, 16]

Advanced Design System 2008

	channelization codes used in a timeslot			
ModType	type of modulation: QPSK, _8PSK	QPSK	enum	

Pin Inputs

Pin	Name	Description	Signal Type
1	Input1	Input data for S-CCPCH1	int
2	Input2	Input data for S-CCPCH2	int

Pin Outputs

Pin	Name	Description	Signal Type
3	Output	output data	complex

Notes/Equations

1. This subnetwork generates secondary common control physical channels. S-CCPCH 1 and S-CCPCH 2 are always used in pairs, mapped onto two code channels with a spreading factor of 16. There can be more than one pair of S-CCPCHs in use in one cell.

The schematic for this subnetwork is shown in the following figure.

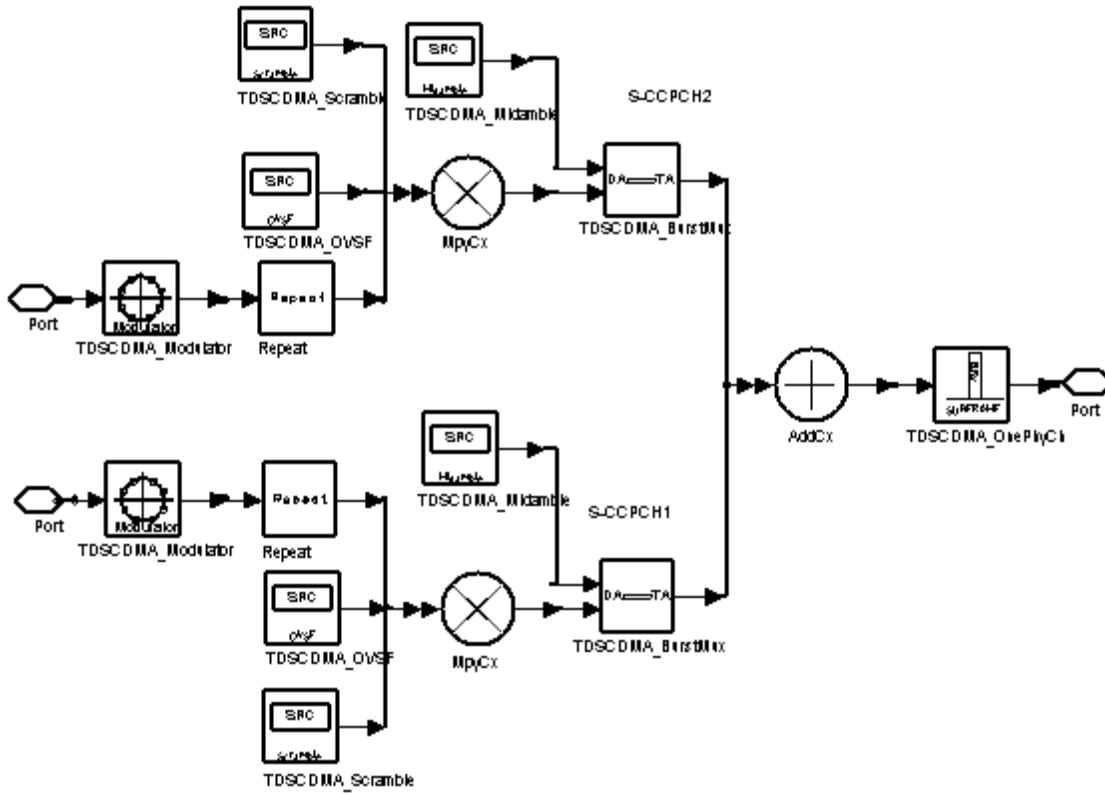

TDSCDMA_SCCPCH Schematic

References

1. 3GPP TS 25.221, 3rd Generation Partnership Project; Technical Specification Group Radio Access Network; Physical channels and mapping of transport channels onto physical channels (TDD) (Release 4), version 4.3.0.

TDSCDMA_UpPCH



Description Uplink synchronization channel generation
 Library TDSCDMA, Physical Channels

Class SDFTDSCDMA_UpPCH

Parameters

Name	Description	Default	Type	Range
SyncCode	index of basic synchronization code	0	int	[0, 255]

Pin Outputs

Pin	Name	Description	Signal Type
1	output	uplink sync code output	complex

Notes/Equations

- This subnetwork generates an uplink synchronization channel. The schematic for this subnetwork is shown in the following figure. Each firing, one sub-frame containing 6400 chips is exported. The uplink synchronization sequence containing 128 chips is exported at location 1057 ~ 1184. Data at other locations is 0.

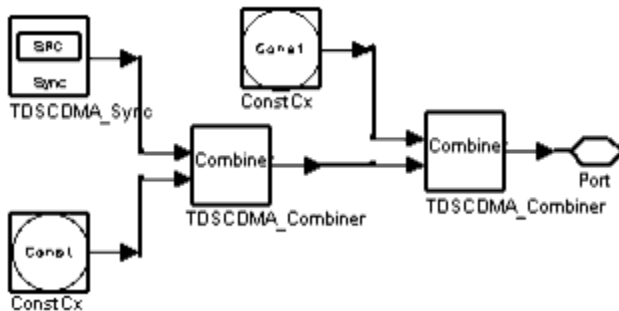

TDSCDMA_UpPCH Schematic

References

- 3GPP TS 25.223, 3rd Generation Partnership Project; Technical Specification Group Radio Access Network; Spreading and modulation (TDD) (Release 4), version 4.3.0, Dec.2001.

Receivers for TD-SCDMA Design Library

TDSCDMA_12_2_DL_JD_Receiver



Description Downlink joint detection receiver with 8 DPCH0

Library TDSCDMA, Receiver

Class TSDFTDSCDMA_12_2_DL_JD_Receiver

Parameters

Name	Description	Default	Unit	Type	Range
RIn	output resistance	DefaultRIn	Ohm	real	(0, ∞)
FCarrier	carrier frequency	1900MHz	Hz	real	{-1} or (0, ∞) ⁺
SamplesPerSymbol	samples per symbol	8		int	[1, 32]
SlotIndex	slot index	6		int	[1, 6]
BasicMidambleID	index of basic midamble	0		int	[0, 127]
K	maximum number of midamble shifts in a cell	16		int	{2, 4, 6, 8, 10, 12, 14, 16}
MidambleID	midamble index	1		int	[1, K]
OCNS_MidambleID	OCNS midamble array	{2, 3, 4, 5, 6, 7, 8, 9}		int array	[1, K]
SpreadCode1	spreading code for the first DPCH	1		int	[1, 16]
SpreadCode2	spreading code for the second DPCH	2		int	[1, 16]

OCNS_SpreadCode	OCNS spreading code array	{ 3, 4, 5, 6, 7, 8, 9, 10}		int array	[1, 16]
FilterLength	length of raised cosine filters in number of symbols	16		int	[1, ∞)
SystemDelay	total system delay in symbols including delay caused by filters	16		int	[1, ∞)
IgnoreNumber	ignored subframe numbers	4		int	[1, ∞)
PowerThreshold	power threshold for channel estimation	0		real	(0, ∞)
PhyChNum_SA	physical channel allocation configuration	0 0 2 0 0 0 0		int array	[0, 16] for Downlink, [0, 2] for Uplink
MaxPhyChNum	sum of allocated physical channel in all slots	2		int	[1, 112]
ModType_SA	type of modulation of all slots, 0 for QPSK, 1 for 8PSK	0 0 0 0 0 0 0		int array	{0, 1}
TFCI_SA	allocated TFCI transmitted active slots configuration	0 0 1 0 0 0 0		int array	{0, 1}
TFCI_Length_SA	length of TFCI of all slots	0 0 16 0 0 0 0		int array	{0, 4, 8, 16, 32} for QPSK, {0, 6, 12, 24, 48} for 8PSK
SS_TPC_SA	type of SS and TPC of all slots	2 2 1 2 2 2 2		int array	{1, 2, 3}
MinSF_PA	minimum spreading factor array corresponding to allocated physical channels	16 16		int array	{1, 16} for Downlink {1, 2, 4, 8, 16} for Uplink

† The FCarrier parameter sets the internal oscillator frequency used for demodulation. Setting FCarrier to -1 will use

the input signal characterization frequency as the internal oscillator frequency.

Pin Inputs

Pin	Name	Description	Signal Type
1	InRF	input signals	timed

Pin Outputs

Pin	Name	Description	Signal Type
2	output	output	int

Notes/Equations

1. This subnetwork is used to implement a 12.2k DL JD receiver.
The schematic for this subnetwork is shown in the following figure.

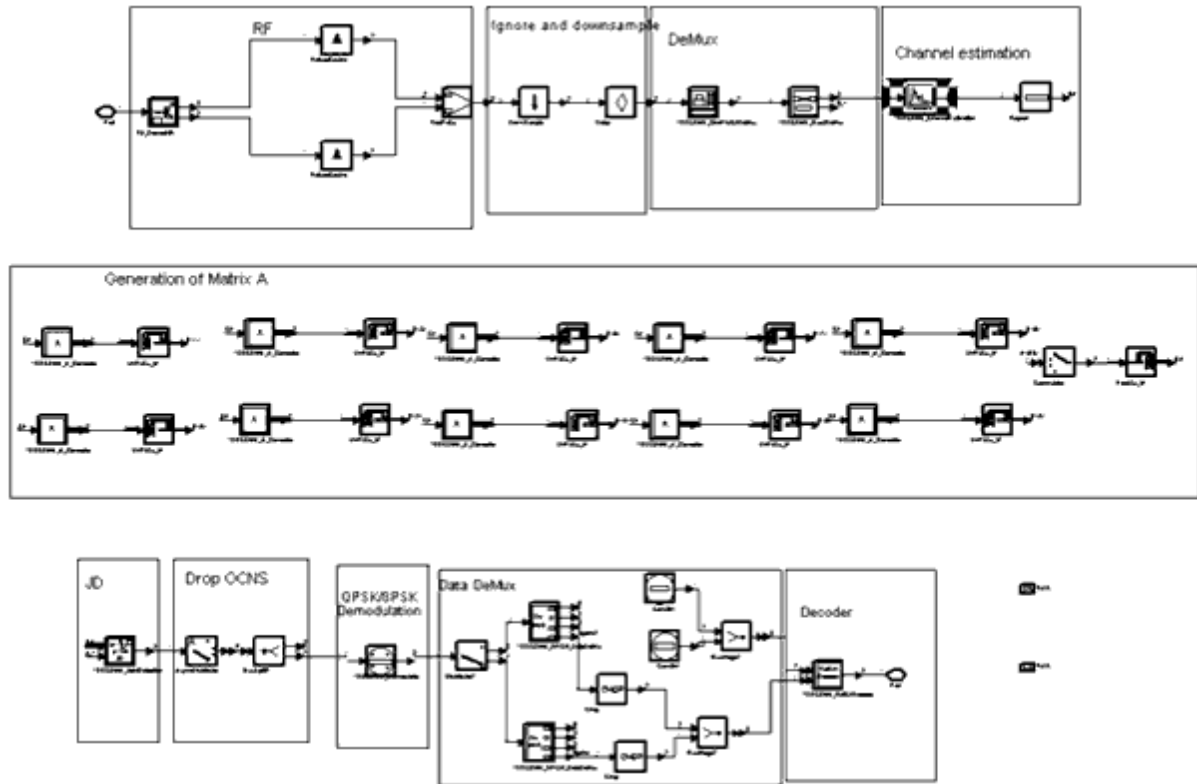

TDSCDMA_12_2_DL_JD_Receiver Schematic

2. The ZF-BLE (zero forcing block linear equalization) joint detection algorithm is applied in this model.

Let

$$d^{(k)} = (d_1^{(k)}, d_2^{(k)}, \dots, d_N^{(k)})^T, k = 1 \dots K'$$

where K is number of users, N is the number of information bits. A is the structure matrix, which is defined in document for TDSCDMA_A_Generator. And n is the stationary white Gaussian noise. Then the received sequence e can be written as

$$e = (e_1, e_2, \dots, e_{N \times Q + W - 1})^T = Ad + n$$

where W is the length of channel impulse response.

In ZF-BLE algorithm, the estimate \hat{d} can be obtained by optimizing

$$(e - A\hat{d})^* R_n^{-1} (e - A\hat{d})$$

where R_n^{-1} is the noise covariance matrix.

Suppose $R_n^{-1} = I$, then from the estimation theory,

$$\hat{d} = (A^* \times A)^{-1} \times A^* \times e$$

References

1. A. Klein and P. W. Baier, "Linear Unbiased Data Estimation in Mobile Radio Systems Applying CDMA" IEEE JASC, vol. 11. no. 7, Sept., 1993, pp.1058-66.
2. 3GPP Technical Specification TS 25.142 V4.5.0, Base station conformance testing (TDD) Release 4.

TDSCDMA_12_2_DL_RakeReceiver



Description Downlink rake receiver

Library TDSCDMA, Receiver

Class TSDFTDSCDMA_12_2_DL_RakeReceiver

Parameters

Name	Description	Default	Unit	Type	Range
RIn	output resistance	DefaultRIn	Ohm	real	$(0, \infty)$
FCarrier	carrier frequency	1900MHz	Hz	real	$\{-1\}$ or $(0, \infty)^+$
AWGN	AWGN channel or not: No, Yes	Yes		enum	
SamplesPerSymbol	samples per symbol	8		int	[1, 32]
SlotIndex	slot index	6		int	[1, 6]
BasicMidambleID	index of basic midamble	0		int	[0, 127]
K	maximum number of midamble shifts in a cell	16		int	{2, 4,6,8,10,12,14,16}
MidambleID	midamble index	1		int	[1, K]
SpreadCode1	spreading code for the first DPCH	1		int	[1, 16]
SpreadCode2	spreading code for the second DPCH	2		int	[1, 16]
FilterLength	length of raised cosine filters in number of symbols	16		int	[1, ∞)
SystemDelay	total system delay in symbols including delay	16		int	[1, ∞)

	caused by filters				
IgnoreNumber	ignored subframe numbers	4		int	[1, ∞)
PowerThreshold	power threshold for channel estimation	0		real	(0, ∞)
PhyChNum_SA	physical channel allocation configuration	0 0 2 0 0 0 0		int array	[0, 16] for Downlink, [0, 2] for Uplink
MaxPhyChNum	sum of allocated physical channel in all slots	2		int	[1, 112]
ModType_SA	type of modulation of all slots, 0 for QPSK, 1 for 8PSK	0 0 0 0 0 0 0		int array	{0, 1}
TFCI_SA	allocated TFCI transmitted active slots configuration	0 0 1 0 0 0 0		int array	{0, 1}
TFCI_Length_SA	length of TFCI of all slots	0 0 16 0 0 0 0		int array	{0, 4,8,16,32} for QPSK, {0,6,12,24,48} for 8PSK
SS_TPC_SA	type of SS and TPC of all slots	2 2 1 2 2 2 2		int array	{1, 2,3}
MinSF_PA	minimum spreading factor array corresponding to allocated physical channels	16 16		int array	{1, 16} for Downlink {1,2,4,8,16} for Uplink

† The FCarrier parameter sets the internal oscillator frequency used for demodulation. Setting FCarrier to -1 will use the input signal characterization frequency as the internal oscillator frequency.

Pin Inputs

Pin	Name	Description	Signal Type
1	InRF	input signals	timed

Pin Outputs

Pin	Name	Description	Signal Type
2	output	output	int

Notes/Equations

- This subnetwork is used to implement 12.2k DL Rake receiver. The schematic for this subnetwork is shown in the following figure.

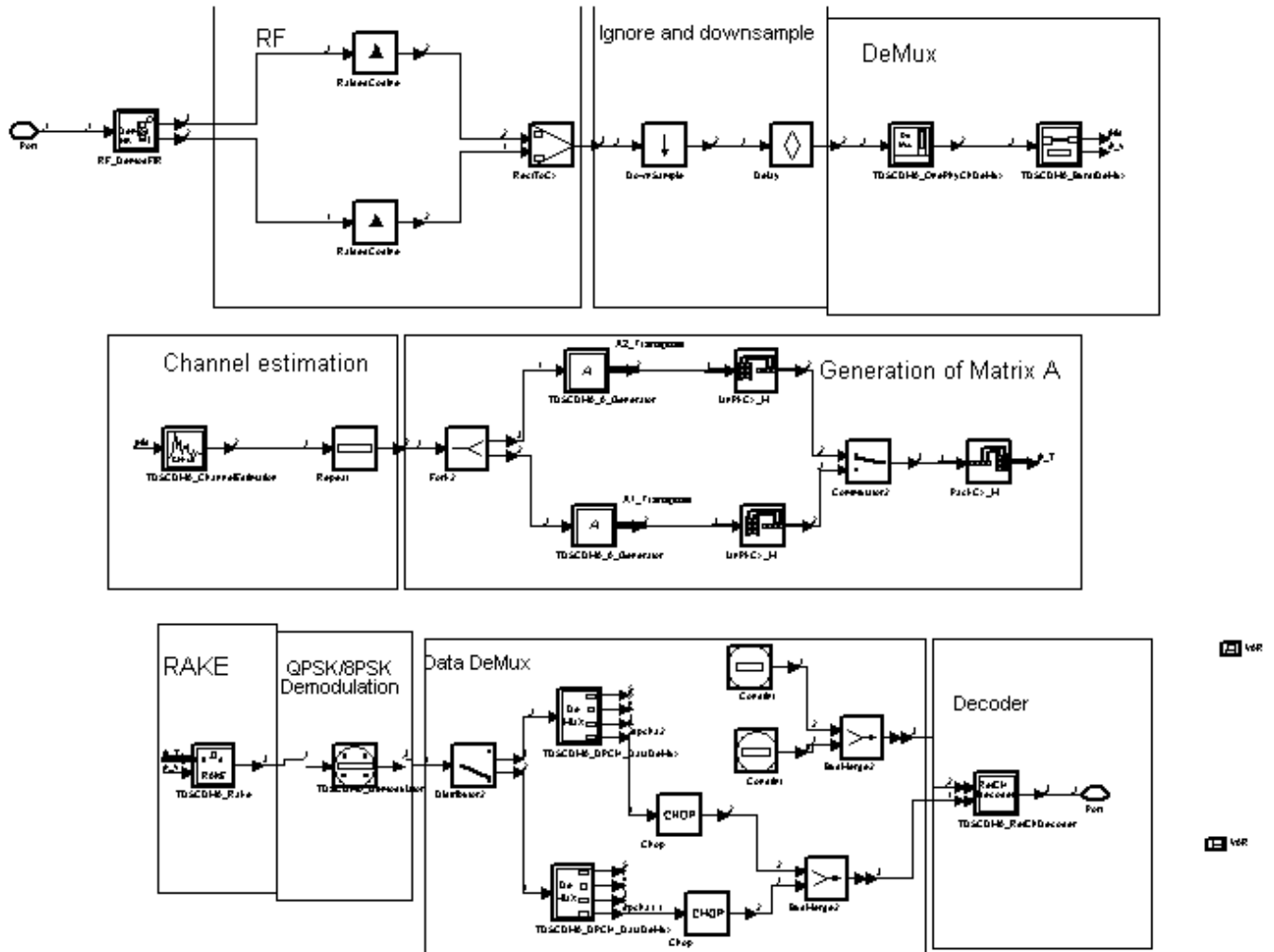

TDSCDMA_12_2_DL_RakeReceiver Schematic

- The received signal is demodulated to baseband and passed through a root raised-cosine filter. Certain delay is added to handle the mis-alignment caused by the filters in the transmitter and the receiver. The baseband signal is then demultiplexed and separated into two parts: midamble signal and data signal. The midamble signal is used to estimate the channel impulse response and further construct Matrix A. The Matrix A and data signal are used to estimate the original data symbols. Different algorithms, RAKE or Joint Detection (JD), can be used in the estimator. In this subnetwork, the core

algorithm is RAKE (also called discrete matched filter). The interference caused by multiple users is ignored. The optimal criteria is to maximize the SNR at the output. If the ZF-BLE JD algorithm is applied, which is the zero forcing block linear equalization algorithm, the noise is ignored, while the interference caused by multiple users is totally eliminated.

After a QPSK/8PSK demodulation, data symbol is converted to data bits. The TFCI, SS and TPC bits are dropped while the information bits are decoded.

Please refer to TDSCDMA_ChannelEstimation, TDSCDMA_A_Generator, TDSCDMA_b_k_Generator, TDSCDMA_RAKE and TDSCDMA_JointDetection for detail information on channel estimation and RAKE/JD core algorithm.

References

1. A. Klein and P. W. Baier, "Linear Unbiased Data Estimation in Mobile Radio Systems Applying CDMA" IEEE JASC, vol. 11. no. 7, Sept. 1993, pp.1058-66.
2. 3GPP Technical Specification TS 25.142 V4.5.0, Base station conformance testing (TDD) Release 4.

TDSCDMA_12_2_UL_JD_Receiver



Description Uplink joint detection receiver with 4 DPCH0

Library TDSCDMA, Receiver

Class TSDFTDSCDMA_12_2_UL_JD_Receiver

Parameters

Name	Description	Default	Unit	Type	Range
RIn	output resistance	DefaultRIn	Ohm	real	$(0, \infty)$
FCarrier	carrier frequency	1900MHz	Hz	real	$\{-1\}$ or $(0, \infty)^+$
SamplesPerSymbol	samples per symbol	8		int	$[1, 32]$
SlotIndex	slot index	2		int	$[1, 6]$

BasicMidambleID	index of basic midamble	0		int	[0, 127]
K	maximum number of midamble shifts in a cell	16		int	{2, 4,6,8,10,12,14,16}
MidambleID	midamble index	1		int	[1, K]
OCNS_MidambleID	OCNS midamble array	{2, 3, 4, 5 }		int array	[1, K]
SpreadCode	spreading code for the first DPCH	1		int	[1, 16]
OCNS_SpreadCode	OCNS spreading code array	{ 3, 4, 5, 6 }		int array	[1, 16]
FilterLength	length of raised cosine filters in number of symbols	16		int	[1, ∞)
SystemDelay	total system delay in symbols including delay caused by filters	16		int	[1, ∞)
IgnoreNumber	ignored subframe numbers	4		int	[1, ∞)
PowerThreshold	power threshold for channel estimation	0		real	(0, ∞)
PhyChNum_SA	physical channel allocation configuration	0 0 1 0 0 0 0		int array	[0, 16] for Downlink, [0, 2] for Uplink
MaxPhyChNum	sum of allocated physical channel in all slots	1		int	[1, 112]
ModType_SA	type of modulation of all slots, 0 for QPSK, 1 for 8PSK	0 0 0 0 0 0 0		int array	{0, 1}
TFCI_SA	allocated TFCI transmitted active slots configuration	0 0 1 0 0 0 0		int array	{0, 1}

Advanced Design System 2008

TFCI_Length_SA	length of TFCI of all slots	0 0 16 0 0 0 0		int array	{0, 4, 8, 16, 32} for QPSK, {0, 6, 12, 24, 48} for 8PSK
SS_TPC_SA	type of SS and TPC of all slots	2 2 1 2 2 2 2		int array	{1, 2,3}
MinSF_PA	minimum spreading factor array corresponding to allocated physical channels	8		int array	{1, 16} for Downlink {1,2,4,8,16} for Uplink

† The FCarrier parameter sets the internal oscillator frequency used for demodulation. Setting FCarrier to -1 will use the input signal characterization frequency as the internal oscillator frequency.

Pin Inputs

Pin	Name	Description	Signal Type
1	InRF	input signals	timed

Pin Outputs

Pin	Name	Description	Signal Type
2	output	output	int

Notes/Equations

1. This subnetwork is used to implement 12.2k UL JD receiver.
The schematic for this subnetwork is shown in the following figure.

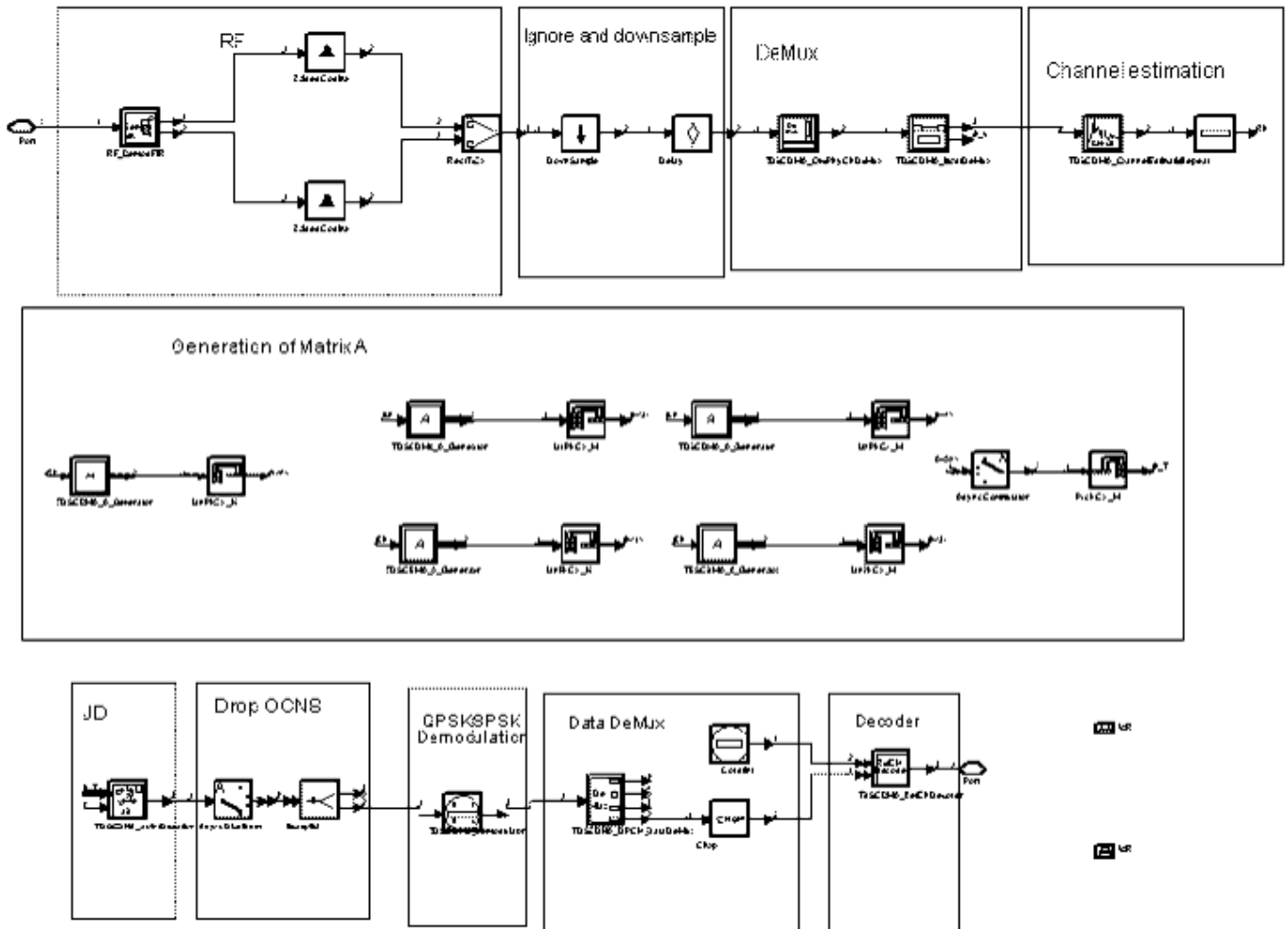

TDSCDMA_12_2_UL_JD_Receiver Schematic

2. Please refer to the [TDSCDMA 12_2_DL_RakeReceiver](#) for the description of the receiver structure and algorithm.

References

1. A. Klein and P. W. Baier, "Linear Unbiased Data Estimation in Mobile Radio Systems Applying CDMA" IEEE JASC, vol. 11. no. 7, Sept. 1993, pp.1058-66.
2. 3GPP Technical Specification TS 34.122 V4.5.0, Terminal Conformance Specification, Radio Transmission and Reception (TDD) (Release 4).



Description Uplink rake receiver
 Library TDSCDMA, Receiver
 Class TSDFTDSCDMA_12_2_UL_RakeReceiver

Parameters

Name	Description	Default	Unit	Type	Range
RIn	output resistance	DefaultRIn	Ohm	real	$(0, \infty)$
FCarrier	carrier frequency	1900MHz	Hz	real	$\{-1\}$ or $(0, \infty)^+$
AWGN	AWGN channel or not: No, Yes	Yes		enum	
SamplesPerSymbol	samples per symbol	8		int	[1, 32]
SlotIndex	slot index	2		int	[1, 6]
BasicMidambleID	index of basic midamble	0		int	[0, 127]
K	maximum number of midamble shifts in a cell	16		int	{2, 4,6,8,10,12,14,16}
MidambleID	midamble index	1		int	[1, K]
SpreadCode	spreading code for the DPCH	1		int	[1, 16]
FilterLength	length of raised cosine filters in number of symbols	16		int	[1, ∞)
SystemDelay	total system delay in symbols including delay caused by filters	16		int	[1, ∞)
IgnoreNumber	ignored subframe numbers	4		int	[1, ∞)

Advanced Design System 2008

PowerThreshold	power threshold for channel estimation	0		real	(0, ∞)
PhyChNum_SA	physical channel allocation configuration	0 0 1 0 0 0 0		int array	[0, 16] for Downlink, [0, 2] for Uplink
MaxPhyChNum	sum of allocated physical channel in all slots	1		int	[1, 112]
ModType_SA	type of modulation of all slots, 0 for QPSK, 1 for 8PSK	0 0 0 0 0 0 0		int array	{0, 1}
TFCI_SA	allocated TFCI transmitted active slots configuration	0 0 1 0 0 0 0		int array	{0, 1}
TFCI_Length_SA	length of TFCI of all slots	0 0 16 0 0 0 0		int array	{0, 4,8,16,32} for QPSK, {0,6,12,24,48} for 8PSK
SS_TPC_SA	type of SS and TPC of all slots	2 2 1 2 2 2 2		int array	{1, 2,3}
MinSF_PA	minimum spreading factor array corresponding to allocated physical channels	8		int array	{1, 16} for Downlink {1,2,4,8,16} for Uplink

† The FCarrier parameter sets the internal oscillator frequency used for demodulation. Setting FCarrier to -1 will use the input signal characterization frequency as the internal oscillator frequency.

Pin Inputs

Pin	Name	Description	Signal Type
1	InRF	input signals	timed

Pin Outputs

Pin	Name	Description	Signal Type
2	output	output	int

Notes/Equations

- This subnetwork is used to implement 12.2k UL Rake receiver.
The schematic for this subnetwork is shown in the following figure.

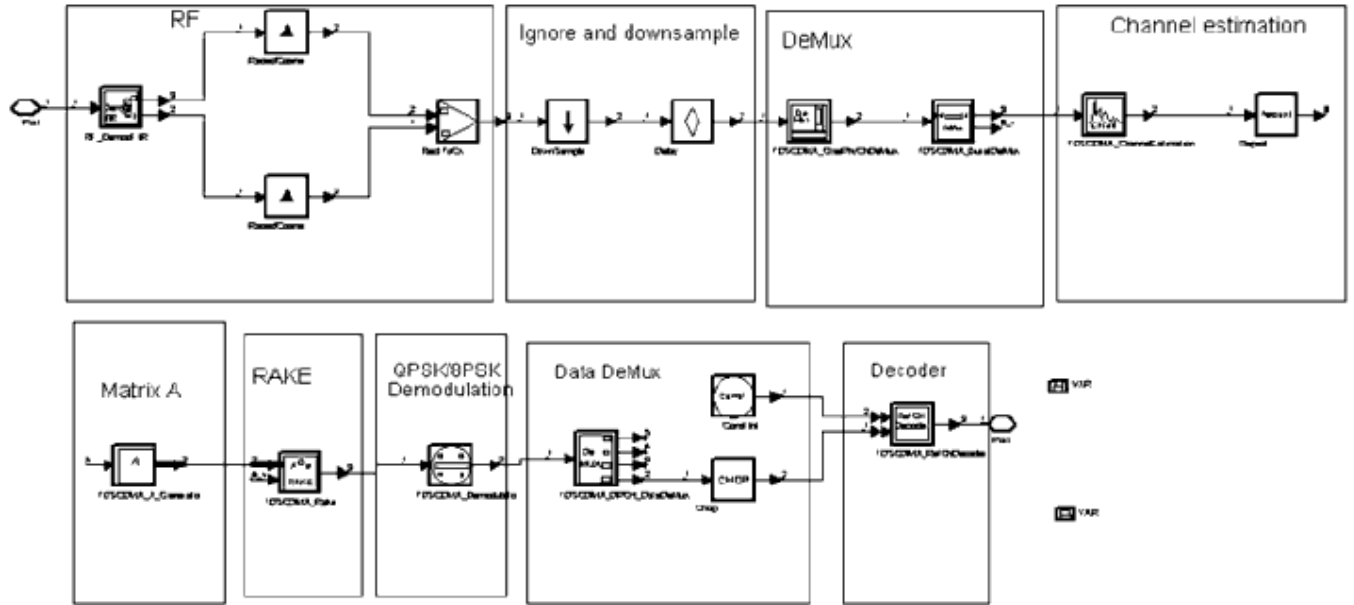

TDSCDMA_12_2_UL_RakeReceiver Schematic

- Please refer to the [TDSCDMA_12_2_DL_RakeReceiver](#) for the description of the receiver structure and algorithm.

References

- A. Klein and P.W.Baier, "Linear Unbiased Data Estimation in Mobile Radio Systems Applying CDMA" IEEE JASC, vol.11. no. 7, Sept. 1993, pp.1058-66.
- 3GPP Technical Specification TS 34.122 V4.5.0, Terminal Conformance Specification, Radio Transmission and Reception (TDD) (Release 4).

TDSCDMA_A_Generator



Description Matrix A generator
 Library TDSCDMA, Receiver
 Class SDFTDSCDMA_A_Generator

Parameters

Name	Description	Default	Type	Range
MidambleID	midamble index	1	int	[1, K]
ScrambleCode	index of scramble code	0	int	[0, 127]
SpreadFactor	spreading factor	16	int	{1, 2,4,8,16}
SpreadCode	index of OVFSF code	1	int	[1, SpreadFactor]
K	maximum number of midamble shifts in a cell	16	int	{2, 4,6,8,10,12,14,16}

Pin Inputs

Pin	Name	Description	Signal Type
1	h	channel impulse response	complex

Pin Outputs

Pin	Name	Description	Signal Type
2	A	matrix A	complex matrix

Notes/Equations

1. This subnetwork is used to generate matrix A, which is used in the Rake or JD receiver. The schematic for this subnetwork is shown in the following figure.

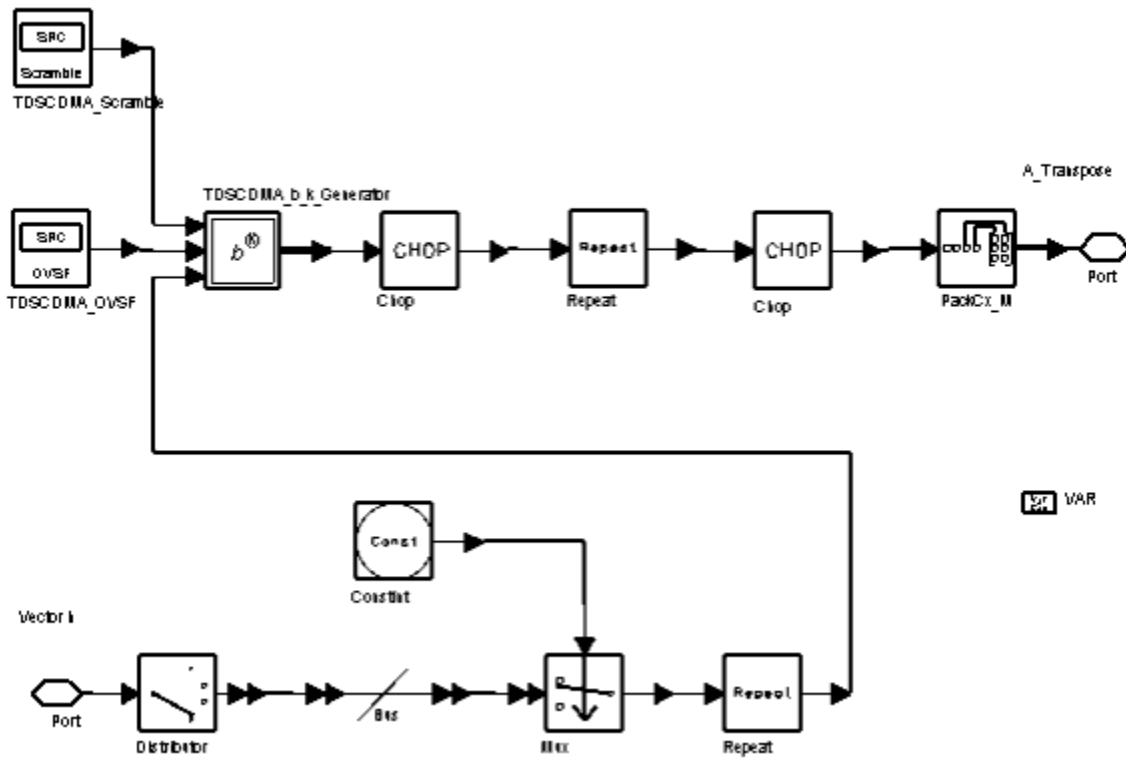

TDSCDMA_A_Generator Schematic

2. Matrix A is illustrated in the following figure.

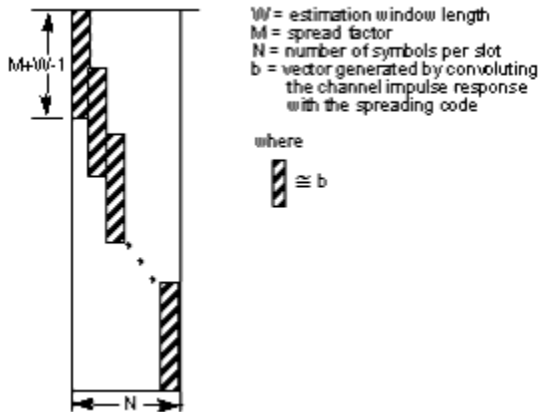

Structure of Matrix A

References

1. A. Klein and P.W.Baier, "Linear Unbiased Data Estimation in Mobile Radio Systems Applying CDMA" IEEE JASC,

TDSCDMA_b_k_Generator

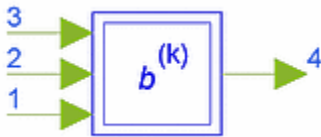

Description Vector b_k generator
 Library TDSCDMA, Receiver
 Class SDFTDSCDMA_b_k_Generator

Parameters

Name	Description	Default	Type	Range
SpreadFactor	spreading factor	16	int	{1, 2,4,8,16}
K	maximum number of midamble shifts in a cell	16	int	{2, 4,6,8,10,12,14,16}

Pin Inputs

Pin	Name	Description	Signal Type
1	h_k	channel impulse response	complex
2	OVSF	OVSF code	complex
3	scrb	scramble code	complex

Pin Outputs

Pin	Name	Description	Signal Type
4	b_k	vectro b_k	complex

Notes/Equations

1. This subnetwork is used to generate vector b_k , which is used to generate matrix A.

The schematic for this subnetwork is shown in the following figure.

- Let W = estimation window length, M = spreading factor and N = number of symbols per slot.
The output b is the convolution of c with h ,
where

$$c = (c_1 c_2 c_3 \dots c_M)^T$$

is the spreading code,

$$h = (h_1 h_2 h_3 \dots h_W)^T$$

is the channel impulse response.

Each firing, M spreading code tokens, M scramble code tokens, and W channel impulse response tokens are consumed; $M+W-1$ output tokens are produced.

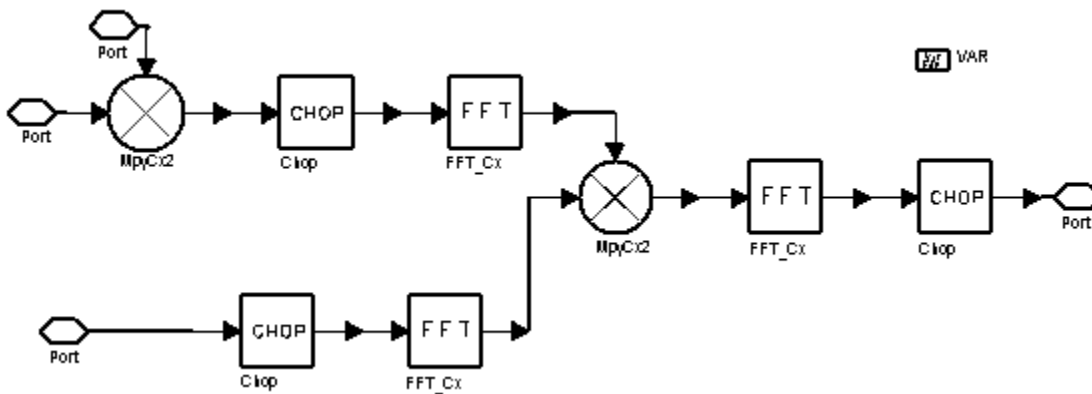

TDSCDMA_b_k_Generator Schematic

References

- A. Klein and P.W.Baier, "Linear Unbiased Data Estimation in Mobile Radio Systems Applying CDMA" IEEE JASC, vol. 11. no.7, Sept. 1993, pp.1058-66.

TDSCDMA_ChannelEstimation



Description Channel estimation
 Library TDSCDMA, Receiver
 Class SDFTDSCDMA_ChannelEstimation

Parameters

Name	Description	Default	Type	Range
BasicMidambleID	index of basic midamble	0	int	[0, 127]
AWGN	AWGN channel or not: No, Yes	Yes	enum	
PowerThreshold	power threshold for channel estimation	0	real	(0, ∞)
K	maximum number of midamble shifts in a cell	16	int	{2, 4,6,8,10,12,14,16}
IgnoreNumber	number of slots to be ignored	4	int	[1, ∞)

Pin Inputs

Pin	Name	Description	Signal Type
1	Mid	received midamble	complex

Pin Outputs

Pin	Name	Description	Signal Type
2	h	channel impulse response	complex

Notes/Equations

- This subnetwork is used to estimate channel impulse response. The schematic for this subnetwork is shown in the following figure. Each firing, 144 tokens are consumed, while 128 tokens are produced.

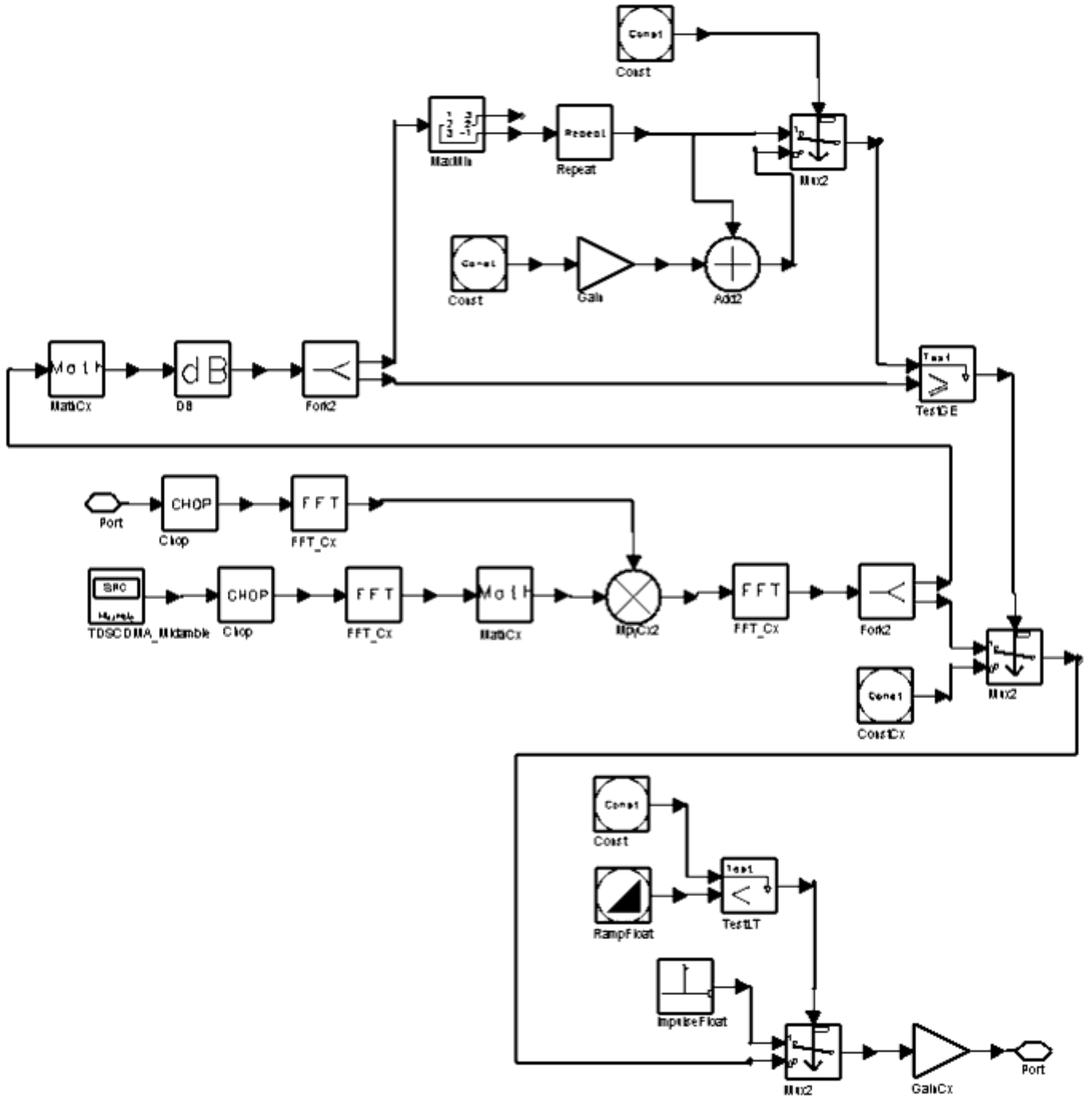

TDSCDMA_ChannelEstimation Schematic

The channel impulse response is calculated by applying FFT. The advantage of FFT/IFFT is the circular characteristic of midamble. After 3 FFT/IFFT the channel impulse response for all the users can be determined. The algorithm is described as follows:

$h(1:128)=128\text{IFFFT}(128\text{FFT}(\text{midamble_data}(16:144))./128\text{FFT}(\text{basic_midamble_code}(16:144)))$

- If channel type is AWGN, there is only one path, so only the path with maximum magnitude is selected. If channel type is not AWGN, PowerThreshold is used to refined the estimation; then

$$h_{refined}(i) = \begin{cases} 0; & \text{if}(\|h_{Max}^2\| - \|h^2(i)\| \geq \text{PowerThreshold}) \\ h(i); & \text{else} \end{cases}$$

References

- 3GPP TS 25.221, 3rd Generation Partnership Project; Technical Specification Group Radio Access Network; Physical channels and mapping of transport channels onto physical channels (TDD) (Release 4), version 4.5.0, Dec., 2001.

TDSCDMA_JointDetection



Description Joint detection receiver
 Library TDSCDMA, Receiver
 Class SDFTDSCDMA_JointDetection

Parameters

Name	Description	Default	Type	Range
K	maximum number of midamble shifts in a cell	16	int	{2, 4, 6, 8, 10, 12, 14, 16}
P	numbers of equivalent channels with spreading factor	2	int	

16

Pin Inputs

Pin	Name	Description	Signal Type
1	input	received signal	complex
2	A	Matrix A	complex matrix

Pin Outputs

Pin	Name	Description	Signal Type
3	output	output	complex

Notes/Equations

- This subnetwork is used to implement core algorithm of joint detection receiver. The schematic for this subnetwork is shown in the following figure.

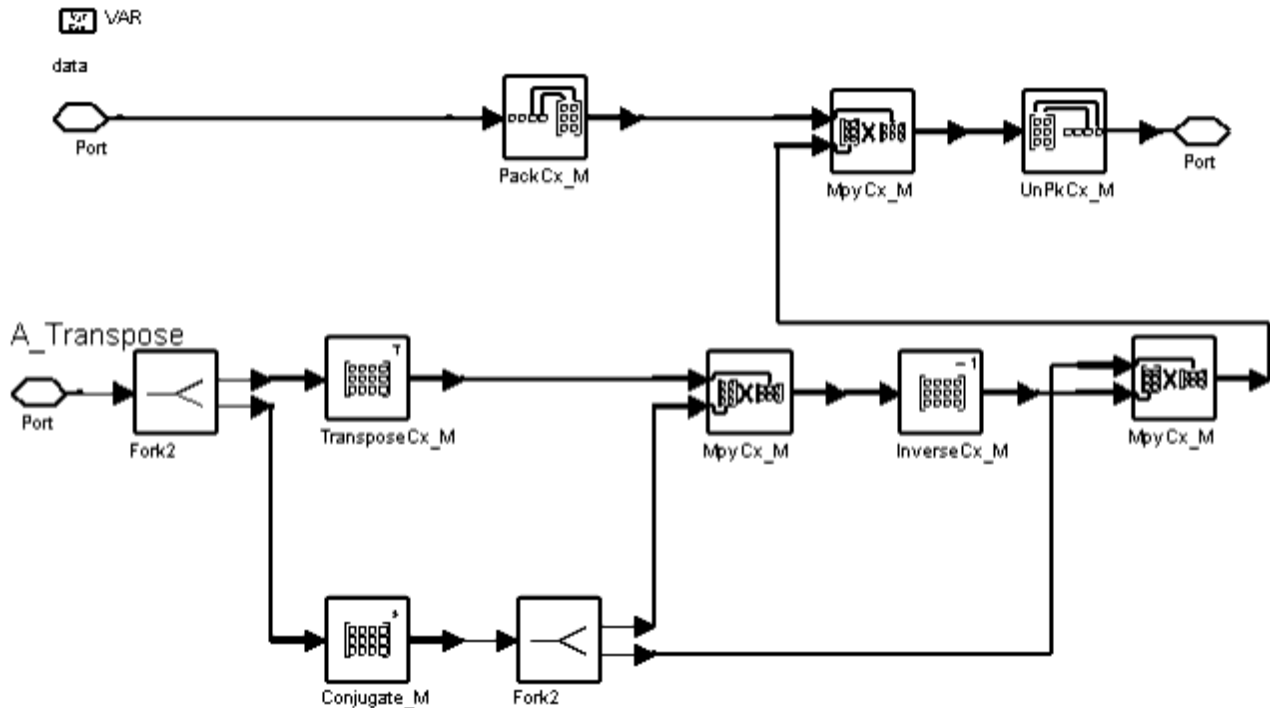

TDSCDMA_JointDetection Schematic

- Let $e = A \cdot d + n$, where $e = (e_1 e_2 e_3 \dots e_{N \cdot M + W - 1})^T$ is the received sequence,

$d = (d_1 d_2 d_3 \dots d_N)^T$ is the symbol sequence, A is the transfer matrix defined in [1] and

TDSCDMA_A_Generator, W is the estimation window length, M denotes the spreading factor and N denotes the number of symbols per slot. Then the zero forcing joint detection receiver could be given by

$$\hat{d}_{JD} = (A^H A)^{-1} A^H e$$

eliminates the multi-user interference to obtain unbiased estimates. Interference results in SNR degradation.

References

1. A. Klein and P.W.Baier, "Linear Unbiased Data Estimation in Mobile Radio Systems Applying CDMA" IEEE JASC, vol.11. no.7, Sept. 1993, pp.1058-66.

TDSCDMA_Rake



Description Rake receiver
 Library TDSCDMA, Receiver
 Class SDFTDSCDMA_Rake

Parameters

Name	Description	Default	Type	Range
K	maximum number of midamble shifts in a cell	16	int	{2, 4,6,8,10,12,14,16}
P	numbers of equivalent channels with spreading factor 16	2	int	[1, 16]

Pin Inputs

Pin	Name	Description	Signal Type
1	input	received signal	complex

2	A	Matrix A	complex matrix
---	---	----------	----------------

Pin Outputs

Pin	Name	Description	Signal Type
3	output	output	complex

Notes/Equations

1. This subnetwork is used to implement core algorithm of Rake receiver. The schematic for this subnetwork is shown in the following figure.

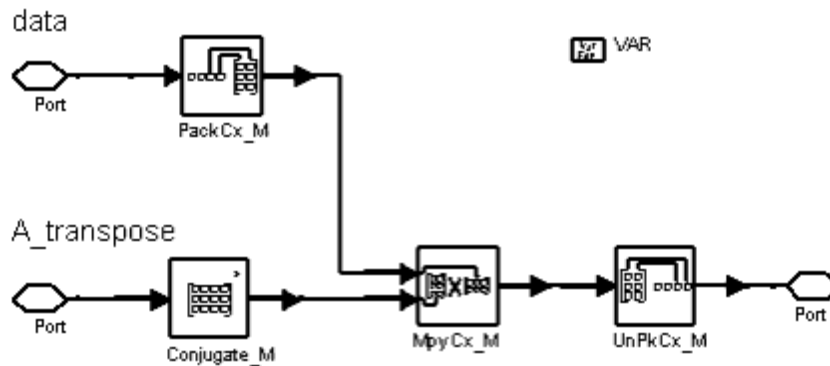

TDSCDMA_Rake Schematic

2. Let $e = A \cdot d + n$, where $e = (e_1 e_2 e_3 \dots e_{N \cdot M + W - 1})^T$ is the received sequence; $n = (n_1 n_2 n_3 \dots n_{N \cdot M + W - 1})^T$ is the noise sequence; $d = (d_1 d_2 d_3 \dots d_N)^T$ is the symbol sequence; A is the transfer matrix defined in [1] and TDSCDMA_A_Generator; W is the estimation window length; M denotes the spreading factor; and, N denotes the number of symbols per slot. Then the matched filter receiver or RAKE receiver could be given by $\hat{d}_{Rake} = A^H e$.

References

1. A. Klein and P.W.Baier, "Linear Unbiased Data Estimation in Mobile Radio Systems Applying CDMA" IEEE JASC, vol. 11. no.7, Sept. 1993, pp. 1058-66.

Signal Sources for TD-SCDMA Design Library

TDSCDMA_DL_RF

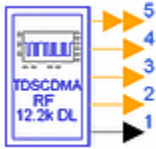

Description TDSCDMA downlink RF signal source

Library TDSCDMA, Signal Sources

Class TSDFTDSCDMA_DL_RF

Parameters

Name	Description	Default	Unit	Type	Range
ROut	output resistance	DefaultROut	Ohm	real	$(0, \infty)$
FCarrier	carrier frequency	1900MHz	Hz	real	$(0, \infty)$
Power	modulator output power	10W	W	real	$(0, \infty)$
SlotIndex	index of slot	6		int	{0, 2,3,4,5,6}
MidambleAllocScheme	midamble allocation scheme: UE_Specific, Common, Default	Default		enum	
BasicMidambleID	index of basic midamble	0		int	[0, 127]
K	maximum number of midamble shifts in a cell	16		int	{2, 4,6,8,10,12,14,16}
MidambleID1	index of midamble for the first DPCH	1		int	[1, K]
MidambleID2	index of midamble for the second DPCH	2		int	[1, K]
SpreadCode1	index of spread code for the first DPCH	1		int	[1, 16]

Advanced Design System 2008

SpreadCode2	index of spread code for the second DPCH	2		int	[1, 16]
PhyChNum	number of channelization codes used in a timeslot	2		int	[1, 16]
SyncCode	index of basic synchronization code	0		int	[0, 31]
ModPhase	type of modulation quadruples: S1, S2	S1		enum	
DwPCH_Gain	Gain for DwPCH	1		int	[0, ∞)
SamplesPerSymbo	samples per symbol period	8		int	[1, 32]
FilterLength	length of raised cosine filters in number of symbols	16		int	(0, ∞)

Pin Outputs

Pin	Name	Description	Signal Type
1	OutRF	output signals	timed
2	TFCI	transport format combination indicator bits	int
3	SS	information bits for uplink synchronization control	int
4	TPC	transmit power control bits	int
5	Data	information data bits	multiple int

Notes/Equations

- This TD-SCDMA signal source generates a 12.2 kbps downlink (DL) RF signal with two dedicated physical channels (DPCH) and one downlink pilot channel (DwPCH). To use this source, the designer typically needs to only set the RF carrier frequency (FCarrier) and power (Power). TD-SCDMA signal characteristics can be specified by setting the FilterLength, ModPhase, MidambleAllocScheme,

SlotIndex, BasicMidambleID, MidambleID1, MidambleID2, K, SpreadCode1, SpreadCode2, DwPCH_Gain and SyncCode parameters.

- This signal source is composed of a DSP section and RF modulo as shown in the the following figure. The RF output from the signal source is at the frequency specified (FCarrier), with the specified source resistance (ROut) and power (Power).

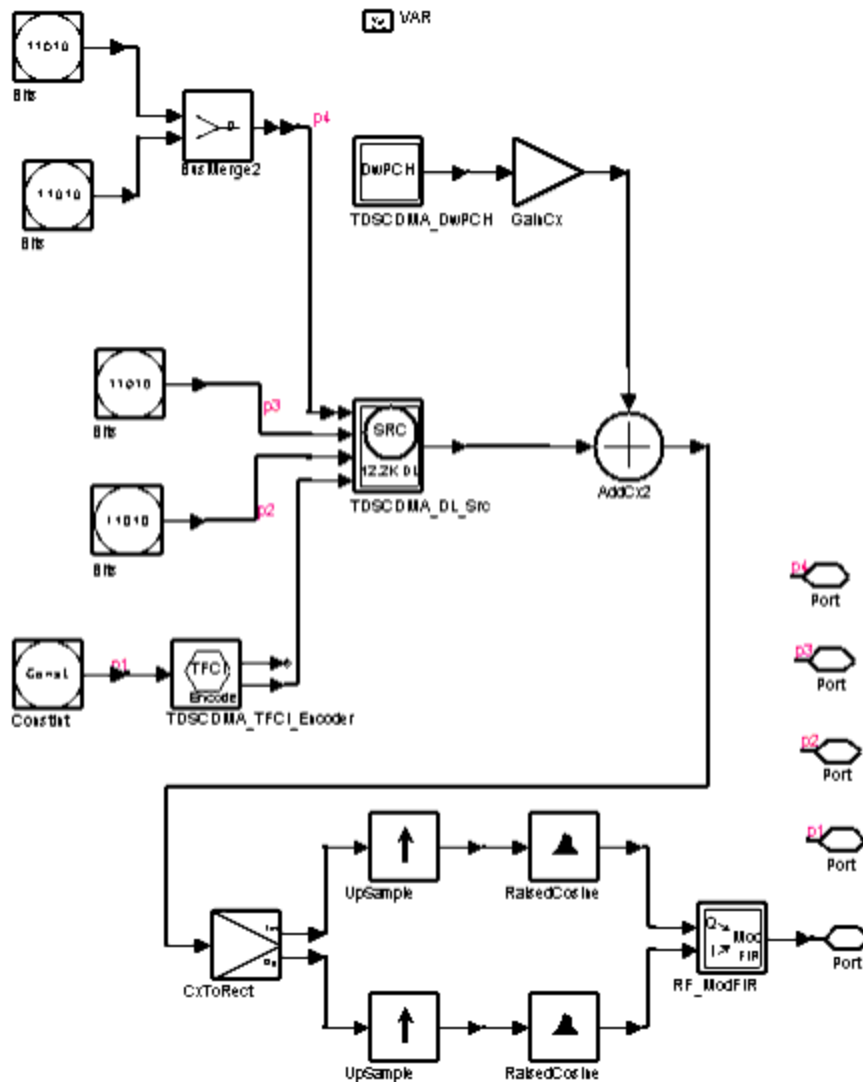

TDSCDMA_DL_RF Schematic

- This TD-SCDMA downlink signal source model is compatible with Agilent Signal Studio software option 411 for transmitter test. Details regarding Signal Studio for TD-SCDMA are included at the website <http://www.agilent.com/find/signalstudio>
- In the TD-SCDMA signal frame structure, one frame consists of two subframes. The subframe structure is illustrated in the following figure. As can be seen, each subframe consists of 7 time slots (TS), and one downlink pilot time slot (DwPTS), one guard period (GP) and one uplink pilot time slot (UpPTS). Each time slot can transmit DPCH signals. A TD-SCDMA chip has a sampling rate of 1.28 MHz.

For example, two DPCH signals in DPCH1 and DPCH2 are transmitted in TS0 shown in the following figure.

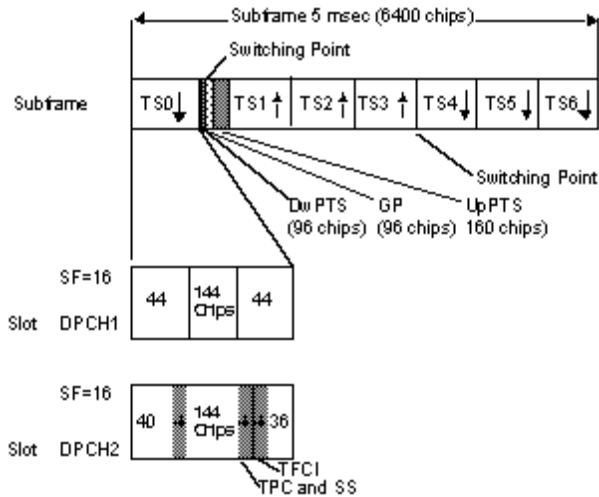

SubFrame Structure of 12.2 kbps DL Channel

5. In general, changing the TD-SCDMA downlink source parameters settings from their default value will affect various transmitter measurements, including power, envelope, CCDF, and spectrum.
6. Parameter details.
 - SamplesPerSymbol sets the number of samples in a chip. The default value of this parameter is set to 8 to display results properly under settings based on 3GPP NTDD standard. Set this value to a larger value if a simulation frequency bandwidth for this signal wider than 8×1.28 MHz is desired. Set this value to a smaller value for faster simulation times, but with lower signal fidelity.
 - FilterLength shows root raised-cosine (RRC) filter length in chips. The default value of this parameter is set to 12 to transmit a TD-SCDMA downlink signal properly in both time and frequency domains based on 3GPP NTDD standard [1-3]. Set this value to a smaller value for faster simulation times, but at the cost of lower signal fidelity.
 - ModPhase is used to select the phase quadruples of DwPTS for different phase rotation pattern. In Signal Studio, a Rotation Phase parameter is used to select the phase quadruples. There are two different phase quadruples, S1 and S2 specified by 3GPP NTDD standard [3]. A quadruple always starts with an even signal frame number. The following table describes the quadruples, where P-CCPCH is the primary common control physical channel.

Phase Modulation Sequences for Downlink Synchronization Code

Name	Phase Quadruple	Description
S1	135,45,225,135	There is a P-CCPCH in the next 4 sub-frames
S2	315,225,315,45	There is no P-CCPCH in the next 4 sub-frames

- MidambleAllocScheme is used to select the midamble allocation scheme. There are three midamble allocation schemes based on 3GPP NTDD standard [1,2].
 UE_Specific: a UE-specific midamble allocation for downlink and uplink is explicitly assigned by higher layers.

Default: the midamble allocation for downlink and uplink is assigned by layer 1 depending on associated channelization code.

Common: the downlink midamble allocation is assigned by layer 1 depending on the number of channelization codes currently present in the downlink time slot.

To set MidambleAllocScheme parameter based on 3GPP NTDD standard [1], related parameters must also be set:

if MidambleAllocScheme = UE_Specific, the BasicMidambleID, K and MidambleID parameters are used to specify which midamble is exported.

if MidambleAllocScheme = Common, only the BasicMidambleID, K are used to specify which midamble is exported, the MidambleID parameter is ignored.

if MidambleAllocScheme = Default, only the BasicMidambleID, K are used to specify which midamble is exported, the MidambleID parameter is ignored.

- SlotIndex parameter is used to select which slot signal in the subframe will be transmitted.
- BasicMidambleID sets the basic midamble code ID. The basic midamble code is used for training sequences for uplink and downlink channel estimation, power measurements and maintaining uplink synchronization. There are 128 different sequences; BasicMidambleID can be set from 0 to 127. In Signal Studio, Basic Midamble ID code has the same meaning as this parameter.
- K is the maximum number of different midamble shifts in a cell that can be decided by maximum users in the cell for current time slot.
- MidambleID1 and MidambleID2 set indices of midambles for the first and second DPCH, respectively. Midambles of different users active in the same cell and the same time slot are cyclically shifted versions of one basic midamble code.

Let $P = 128$, the length of basic midamble, then $W = \left\lfloor \frac{P}{K} \right\rfloor$, is the shift between midambles and $\lfloor x \rfloor$ denotes

the largest number less or equal to x . MidambleID range is from 1 to K .

MidambleID and K together correspond to parameter of Midamble Offset in Signal Studio for Timeslot setup.

Midamble Offset = MidambleID \times W .

- SpreadCode1 and SpreadCode2 set spread code indices for the first and second DPCH, respectively. For this signal source, the spreading factor is 16. In Signal Studio, Channelization code for Time slot setup has the same meaning as SpreadCode1 and SpreadCode2.
- DwPCH_Gain sets the gain of DwPCH relative to DPCH. In Signal Studio, there are dialog boxes with dB unit for each DwPCH to set the gain of DwPCH relative to DPCH.
- SyncCode sets the downlink pilot synchronization sequence (SYNC-DL). Downlink pilot synchronization is used for downlink synchronization and cell initial search. There are 32 different SYNC-DL code groups that are used to distinguish base stations.

DwPTS is composed of 64 chips of a complex SYNC_DL sequence:

$$\underline{s} = (s_{-1}, s_{-2}, \dots, s_{-64})$$

and 32 chips of guard period.

To generate the complex SYNC_DL code, the basic SYNC_DL code

$$\underline{s} = (s_1, s_2, \dots, s_{64})$$

is used.

There are 32 different basic SYNC_DL codes for the entire system. The relation between s and s_{-} is given by:

$$s_{-i} = (j)^i s_i \text{ where } v_i \in \{1, -1\}, i = 1, \dots, 64$$

Therefore, the elements s_{-i} of \underline{s}_{-} are alternating real and imaginary.

In Signal Studio, SYNC Code is used to set the downlink pilot code.

References

1. 3GPP TS 25.221, 3rd Generation Partnership Project; Technical Specification Group Radio Access Network; Physical channels and mapping of transport channels onto physical channels (TDD) (Release 4), version 4.5.0, Dec., 2001.
2. 3GPP TS 25.223, 3rd Generation Partnership Project; Technical Specification Group Radio Access Network; Spreading and modulation (TDD) (Release 4), version 4.3.0, Dec., 2001.
3. 3GPP TS 25.105, 3rd Generation Partnership Project; Technical Specification Group Radio Access Network; BS Radio transmission and Reception (TDD) (Release 4), version 4.5.0, June 2002.

TDSCDMA_DL_Src

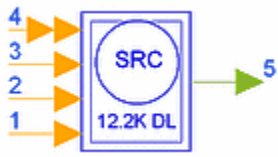

Description TDSCDMA downlink signal source

Library TDSCDMA, Signal Sources

Class SDFTDSCDMA_DL_Src

Parameters

Name	Description	Default	Type	Range
SlotIndex	index of slot	6	int	{0, 2,3,4,5,6}
MidambleAllocScheme	midamble allocation scheme: UE_Specific, Common, Default	Default	enum	
BasicMidambleID	index of basic midamble	0	int	[0, 127]
K	maximum number of midamble shifts in a cell	16	int	{2, 4,6,8,10,12,14,16}
MidambleID1	index of midamble for the first DPCH	1	int	[1, K]
MidambleID2	index of midamble	2	int	[1, K]

Advanced Design System 2008

	for the second DPCH			
SpreadCode1	index of spread code for the first DPCH	1	int	[1, 16]
SpreadCode2	index of spread code for the second DPCH	2	int	[1, 16]
PhyChNum	number of channelization codes used in a timeslot	2	int	[1, 16]

Pin Inputs

Pin	Name	Description	Signal Type
1	TFCI	transport format combination indicator bits	int
2	SS	information bits for uplink synchronization control	int
3	TPC	transmit power control bits	int
4	input	input data	multiple int

Pin Outputs

Pin	Name	Description	Signal Type
5	Output	output data	complex

Notes/Equations

- This subnetwork generates a downlink signal source with 12.2 kbps that includes two DPCHs. The schematic for this subnetwork is shown in the following figure.

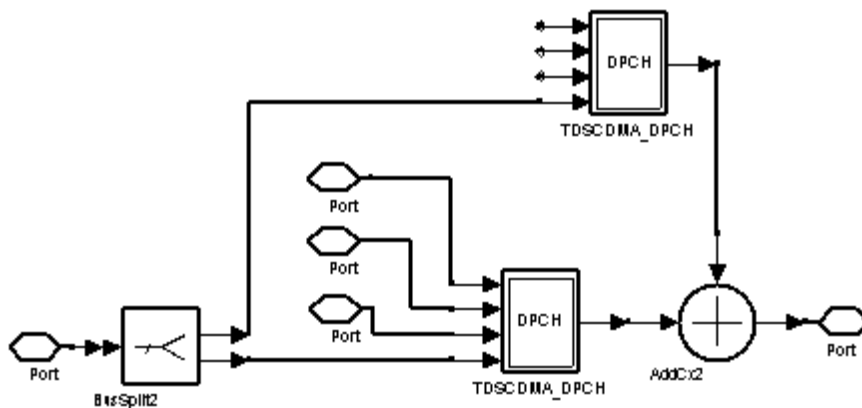

TDSCDMA_DL_Src Schematic

2. The frame structure is illustrated in the following figure.

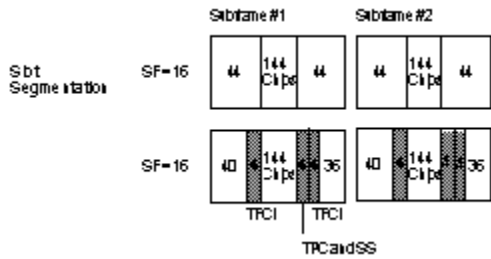

Frame Structure of 12.2 kbps Downlink Channel

References

1. 3GPP TS 25.105, 3rd Generation Partnership Project; Technical Specification Group Radio Access Network; UTRA(BS) TDD; Radio Transmission and Reception (Release 4), version 4.2.0.

TDSCDMA_DnLinkRF

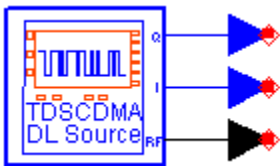

Description TD-SCDMA downlink signal source
 Library TDSCDMA, Signal Sources
 Class TSDFTDSCDMA_DnLinkRF
 Derived From baseARFsource

Parameters

Name	Description	Default	Sym	Unit	Type	Range
ROut	Source resistance	DefaultROut		Ohm	real	(0, ∞)
RTemp	Temperature	DefaultRTemp		Celsius	real	[-273.15, ∞)
TStep	Expression	1/1.28			string	

Advanced Design System 2008

	showing how TStep is related to the other source parameters	MHz/SamplesPerChip				
FCarrier	Carrier frequency	1900 MHz		Hz	real	(0, ∞)
Power	Power	0.01		W	real	[0, ∞)
MirrorSpectrum	Mirror spectrum about carrier? NO, YES	NO			enum	
GainImbalance	Gain imbalance, Q vs I	0.0		dB	real	(-∞, ∞)
PhaseImbalance	Phase imbalance, Q vs I	0.0		deg	real	(-∞, ∞)
I_OriginOffset	I origin offset (percent)	0.0			real	(-∞, ∞)
Q_OriginOffset	Q origin offset (percent)	0.0			real	(-∞, ∞)
IQ_Rotation	IQ rotation	0.0		deg	real	(-∞, ∞)
SamplesPerChip	Samples per chip	8	S		int	[2, 32]
RRC_FilterLength	RRC filter length (chips)	12			int	[2, 128]
ModPhase	Modulation phase quadruples: S1, S2	S1			enum	
MidambleAllocScheme	Midamble allocation scheme: UE_Specific, Common, Default	Common			enum	
BasicMidambleID	Basic midamble index	0			int	[0, 127]
MidambleID1	1st DPCH	1			int	[1, K]

Advanced Design System 2008

	midamble index					
MidambleID2	2nd DPCH midamble index	2			int	[1, K]
MaxMidambleShift	Max midamble shift	16	K		int	{2, 4, 6, 8, 10, 12, 14, 16}
SpreadCode1	1st DPCH spread code index	1			int	[1, 16]
SpreadCode2	2nd DPCH spread code index	2			int	[1, 16]
DwPCH_Gain	DwPCH gain	1			int	(0, ∞)
DownlinkPilotCode	Downlink pilot code index	0			int	[0, 31]
ActiveTimeslot	Slot index: TS0, TS2, TS3, TS4, TS5, TS6	TS6			enum	

Pin Outputs

Pin	Name	Description	Signal Type
1	RF	RF output	timed
2	I	I symbols	real
3	Q	Q symbols	real

Notes/Equations

1. This TD-SCDMA signal source generates a 12.2 kbps downlink RF signal with two dedicated physical channels (DPCH) and one downlink pilot channel (DwPCH). The RF signal has a chip rate of 1.28 MHz. The downlink is from the base station to the user equipment.
To use this source, the designer needs to set (as a minimum) RF carrier frequency (FCarrier) and power (Power). RF impairments can be introduced by setting the ROut, RTemp, MirrorSpectrum, GainImbalance, PhaseImbalance, I_OriginOffset, Q_OriginOffset, and IQ_Rotation parameters.
TD-SCDMA signal characteristics can be specified by setting the RRC_FilterLength, ModPhase, MidambleAllocScheme, BasicMidambleID, MidambleID1, MidambleID2, MaxMidambleShift, SpreadCode1, SpreadCode2, DwPCH_Gain, DownlinkPilotCode, and ActiveTimeslot parameters.

Note
While the function of this model is similar to TDSCDMA_DL_RF, some parameter and output pins are different.

2. This signal source includes a DSP section, RF modulator, and RF output resistance as illustrated in the following figure.

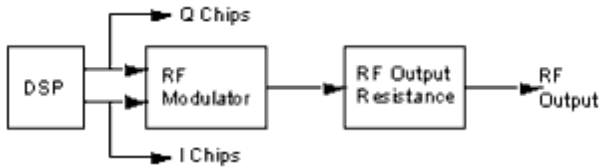

Signal Source Block Diagram

The ROut and RTemp parameters are used by the RF output resistance. The FCarrier, Power, MirrorSpectrum, GainImbalance, PhaseImbalance, I_OriginOffset, Q_OriginOffset, and IQ_Rotation parameters are used by the RF modulator. The remaining signal source parameters are used by the DSP block.

The RF output from the signal source is at the frequency specified (FCarrier), with the specified source resistance (ROut) and with power (Power) delivered into a matched load of resistance ROut. The RF signal has additive Gaussian noise power set by the resistor temperature (RTemp).

The I and Q outputs are baseband outputs with zero source resistance and contain the unfiltered I and Q chips available at the RF modulator input. Because the I And Q outputs are from the inputs to the RF modulator, the RF output signal has a time delay relative to the I and Q chips. This RF time delay (RF_Delay) is related to parameter value for RRC_FilterLength.

$$RF_Delay = RRC_FilterLength / (1.28e6) / 2 \text{ sec.}$$

3. The RF power delivered into a matched load with resistance ROut is the average power delivered in the subframe time slot specified by ActiveTimeslot (this is not the the average frame power, which is less). The following figure shows the RF envelope for an output RF signal with 30 dBm power delivered in time slot 6 (ActiveTimeSlot = TS6).

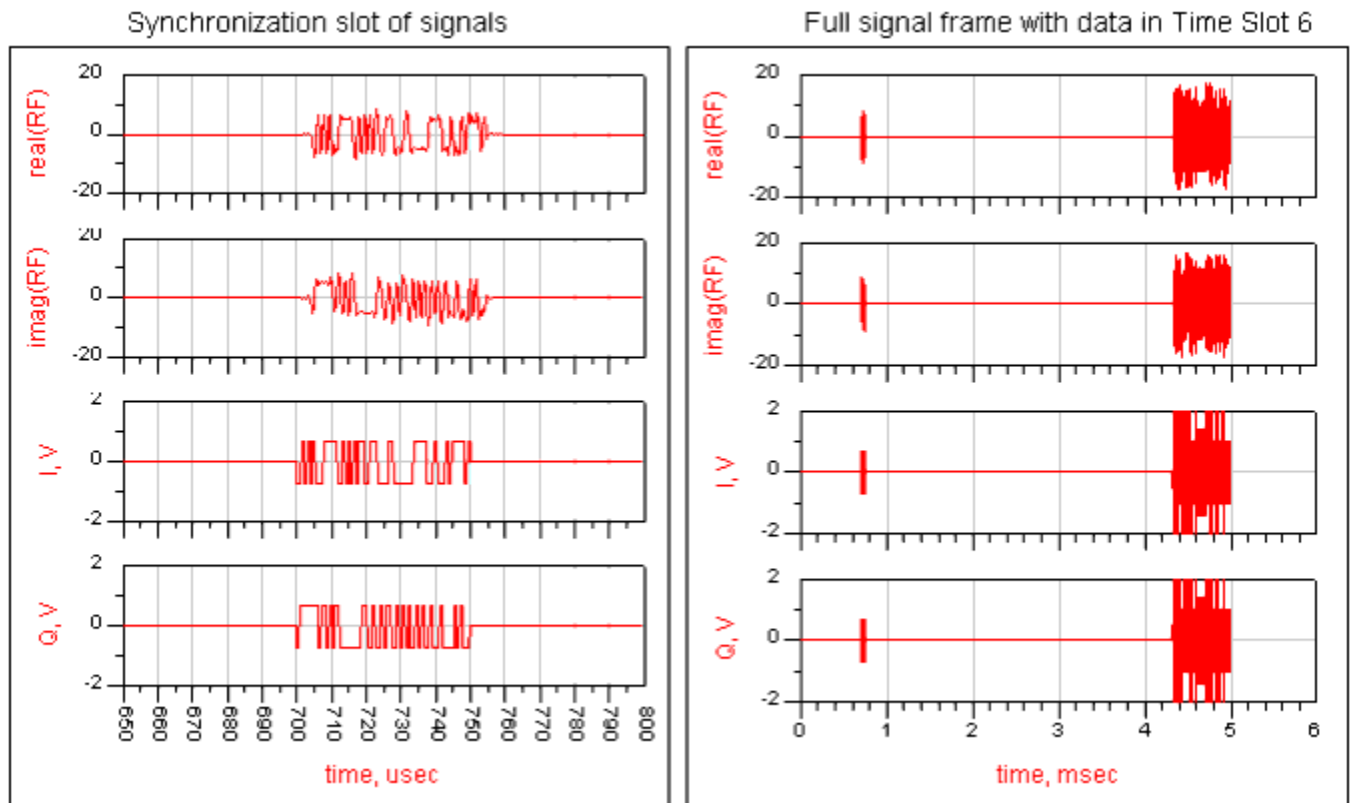

TD-SCDMA Downlink Source

- This TD-SCDMA downlink signal source model is compatible with Agilent Signal Studio software option 411 for transmission test.

Details regarding Signal Studio for TD-SCDMA are included at the website

<http://www.agilent.com/find/signalstudio>

Note

There are two standards for TD-SCDMA systems: the international standard is called the 3GPP NTDD standard; the China national standard is called the TD-SCDMA TSM standard. This partially-coded TD-SCDMA signal source in ADS is based on the 3GPP NTDD standard. The Agilent TD-SCDMA Signal Studio signal source is based on the TD-SCDMA TSM standard. For TD-SCDMA transmission tests, this partially-coded TD-SCDMA signal source in ADS is compatible with the Agilent Signal Studio signal source.

- In the TD-SCDMA signal frame structure, one frame consists of two subframes. Each subframe consists of 7 time slots (TS), and one downlink pilot time slot (DwPTS), one guard period (GP) and one uplink pilot time slot (UpPTS). Each time slot can transmit DPCH signals. One subframe is composed of 6400 chips. Because the chip rate is 1.28 MHz, the subframe has a 5 msec duration. The subframe structure is illustrated in the following figure.

For example, two DPCH signals in DPCH1 and DPCH2 are transmitted in TS0 as illustrated in the following figure. The first DPCH bits are modulated by QPSK and Spread by Walsh code of length 16 then transmitted in the slot. The DPCH1 signal is comprised of 88 coded information bits ($88 \times 16/2$ chips) and 144 chips for midamble sequence plus 16 chips for GP. The DPCH2 signal, with the same modulation and spread scheme as DPCH1, is composed of 76 coded information bits ($76 \times 16/2$ chips), 8 bits ($8 \times 16/2$ chips) for transport format combination indicator (TFCI), 144 chips for midamble sequence, 4 bits ($4 \times 16/2$ chips) for transmitter power

control and synchronization shift (TPC and SS) plus 16 chips for GP. The total chips for the subframe is composed of 7 time slots plus 96 chips for DwPTS, 96 chips for GP and 160 chips for UpPTS and summarized as $(88 \times 8 + 144 + 16) \times 7 + 160 + 96 \times 2 = 6400$ chips.

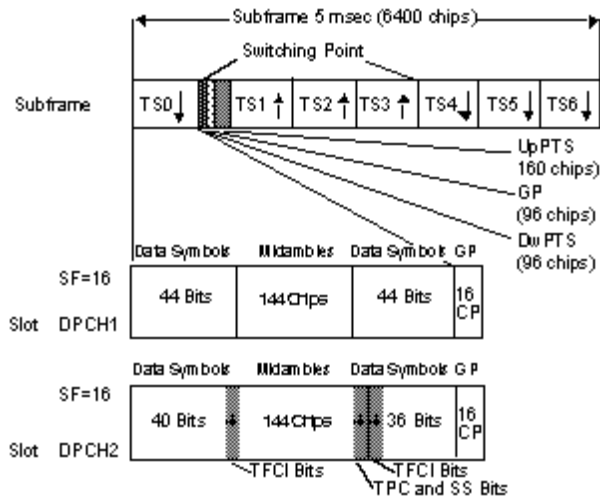

Subframe Structure of 12.2 kbps DL Channel

6. Parameter Details

- The ROut parameter is the RF output source resistance.
 - The RTemp parameter is the RF output source resistance temperature in Celsius and sets the noise density in the RF output signal to $(k(RTemp + 273.15))$ Watts/Hz, where k is Boltzmann's constant.
 - The FCarrier parameter is the RF output signal frequency.
 - The Power parameter is the RF output signal power. The Power of the signal is defined as the average power delivered in the subframe time slot specified by ActiveTimeslot. Refer to [note 3](#) for details.
 - The MirrorSpectrum parameter is used to mirror the RF_out signal spectrum about the carrier. This is equivalent to conjugating the complex RF envelope voltage.
- Depending on the configuration and number of mixers in an RF transmitter, the RF output signal from hardware RF generators can be inverted. If such an RF signal is desired, set this parameter to YES.
- The GainImbalance, PhaseImbalance, I_OriginOffset, Q_OriginOffset, and IQ_Rotation parameters are used to add certain impairments to the ideal output RF signal. Impairments are added in the order described here.

The unimpaired RF I and Q envelope voltages have gain and phase imbalance applied. The RF is given by:

$$V_{RF}(t) = A \left(V_I(t) \cos(\omega_c t) - g V_Q(t) \sin\left(\omega_c t + \frac{\phi\pi}{180}\right) \right)$$

where A is a scaling factor based on the Power and ROut parameters specified by the user, $V_I(t)$ is the in-phase RF envelope, $V_Q(t)$ is the quadrature phase RF envelope, g is the gain imbalance

$$g = 10^{\frac{\text{GainImbalance}}{20}}$$

and, ϕ (in degrees) is the phase imbalance.

Next, the signal $V_{RF}(t)$ is rotated by IQ_Rotation degrees. The I_OriginOffset and Q_OriginOffset are then applied to the rotated signal. Note that the amounts specified are percentages with respect to the output rms voltage. The output rms voltage is given by $\sqrt{2 \times ROut \times Power}$.

- The SamplesPerChip parameter sets the number of samples in a chip.

The default value of this parameter is set to 8 to display settings according to the 3GPP NTDD. It can be set to a larger value for a simulation frequency bandwidth wider than 8×1.28 MHz. It can be set to a smaller value for faster simulation; however, this will result in lower signal fidelity. If SamplesPerChip = 8, the simulation RF bandwidth is larger than the signal bandwidth by a factor of 8 (e.g., simulation RF bandwidth = 8×1.28 MHz).

- The RRC_FilterLength parameter is used to set root raised-cosine (RRC) filter length in number of chips. The default value of this parameter is set to 12 to transmit TD-SCDMA downlink signals in time and frequency domains based on the 3GPP NTDD standard [1] - [3]. It can be set to a smaller value for faster simulation; however, this will result in lower signal fidelity.
- ModPhase is used to select the phase quadruples of DwPTS for various phase rotation patterns. In Signal Studio, the Rotation Phase parameter is used to select the phase quadruples. There are two different phase quadruples, S1 and S2 specified by 3GPP NTDD standard [3], as described in the following table. A quadruple always starts with an even signal frame number.

Phase Modulation Sequences

Name	Phase Quadruple	Description
S1	135, 45, 225, 135	A P-CCPCH is present in the next 4 sub-frames
S2	315, 225, 315, 45	A P-CCPCH is not present in the next 4 sub-frames

- MidambleAllocScheme is used to select the midamble allocation scheme. There are three midamble allocation schemes based on the 3GPP NTDD standard [1], [2].
 UE specific midamble allocation a UE specific midamble for uplink and downlink is explicitly assigned by higher layers
 Default midamble allocation the midamble for uplink and downlink is assigned by layer 1 depending on associated channelization code.
 Common midamble allocation the midamble for downlink is allocated by layer 1 depending on the number of channelization codes currently present in the downlink time slot.
 To set MidambleAllocScheme parameter based on the 3GPP NTDD standard [1], related parameters must be set as stated here:
 if MidambleAllocScheme=UE_Specific, the BasicMidambleID, MaxMidambleShift and MidambleID parameters are used to specify which midamble is exported.
 if MidambleAllocScheme=Common, only the BasicMidambleID, MaxMidambleShift are used to specify which midamble is exported; the MidambleID parameter is ignored.
 if MidambleAllocScheme=Default, only the BasicMidambleID, MaxMidambleShift are used to specify which midamble is exported, the MidambleID parameter is ignored.
- BasicMidambleID sets the basic midamble code ID. The basic midamble code is used for training sequences for uplink and downlink channel estimation, power measurements and maintaining uplink synchronization. There are 128 different sequences; BasicMidambleID can be set from 0 to 127.
 In Signal Studio, Basic Midamble ID code has the same meaning as this parameter.
- MaxMidambleShift is the maximum number of different midamble shifts in a cell that can be determined by maximum users in the cell for the current time slot.
- MidambleID1 and MidambleID2 set the indices of midambles for the first and second DPCH, respectively. Midambles of different users active in the same cell and the same time slot are cyclically shifted versions of one basic midamble code.
 Let $P = 128$, the length of basic midamble and $K = \text{MaxMidambleShift}$, then

$\left\lfloor \frac{P}{K} \right\rfloor$, is the shift between midambles and $\lfloor x \rfloor$ denotes the largest number less or equal to x. The

MidambleID range is from 1 to MaxMidambleShift.

MidambleID and MaxMidambleShift together correspond to parameter of Midamble Offset in Signal Studio for Timeslot setup. Midamble Offset = MidambleID \times W.

- SpreadCode1 and SpreadCode2 set spread code indices for the first and second DPCH, respectively. For this signal source, the spreading factor is 16.

In Signal Studio, channelization code for time slot setup has the same meaning as SpreadCode1 and SpreadCode2.

- DwPCH_Gain sets the gain of DwPCH relative to DPCH.

In Signal Studio, there are dialog boxes with dB unit for each DwPCH to set the gain of DwPCH relative to DPCH.

- DownlinkPilotCode sets the downlink pilot synchronization sequence (SYNC-DL). Downlink pilot synchronization is used for DL synchronization and cell initial search. There are 32 different SYNC-DL code groups, which are used to distinguish base stations.

DwPTS has 64 chips of a complex SYNC_DL sequence $\underline{s} = (s_{-1}, s_{-2}, \dots, s_{-64})$ and 32 chips of guard

period. To generate the complex SYNC_DL code, the basic SYNC_DL code $\underline{s} = (s_1, s_2, \dots, s_{64})$ is

used. There are 32 different basic SYNC_DL codes for the whole system. The relation between \underline{s} and \underline{s} is given by:

$$s_{-i} = (j)^i s_i \text{ where } v_i \in \{1, -1\}, i = 1, \dots, 64$$

Therefore, the elements s_{-i} of \underline{s} are alternating real and imaginary.

In Signal Studio, SYNC Code is used to set the downlink pilot code.

- The ActiveTimeslot parameter is used to select which slot signal in the subframe will be transmitted.

References

1. 3GPP TS 25.221, 3rd Generation Partnership Project; Technical Specification Group Radio Access Network; Physical channels and mapping of transport channels onto physical channels (TDD) (Release 4), version 4.5.0, Dec., 2001.
http://www.3gpp.org/ftp/Specs/2001-12/Rel-4/25_series/25221-430.zip
2. 3GPP TS 25.223, 3rd Generation Partnership Project; Technical Specification Group Radio Access Network; Spreading and modulation (TDD) (Release 4), version 4.3.0, Dec., 2001.
http://www.3gpp.org/ftp/Specs/2001-12/Rel-4/25_series/25223-430.zip
3. 3GPP TS 25.105, 3rd Generation Partnership Project; Technical Specification Group Radio Access Network; BS Radio transmission and Reception (TDD) (Release 4), version 4.5.0, June 2002.
http://www.3gpp.org/ftp/Specs/2002-06/Rel-4/25_series/25105-450.zip

TDSCDMA_UpLinkRF

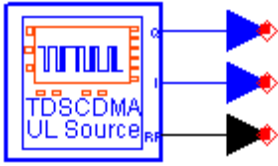

Description TD-SCDMA uplink signal source
 Library TDSCDMA, Signal Sources
 Class TSDFTDSCDMA_UpLinkRF
 Derived From baseARFsource

Parameters

Name	Description	Default	Sym	Unit	Type	Range
ROut	Source resistance	DefaultROut		Ohm	real	(0, ∞)
RTemp	Temperature	DefaultRTemp		Celsius	real	[-273.15, ∞)
TStep	Expression showing how TStep is related to the other source parameters	1/1.28 MHz/SamplesPerChip			string	
FCarrier	Carrier frequency	1900 MHz		Hz	real	(0, ∞)
Power	Power	0.01		W	real	[0, ∞)
MirrorSpectrum	Mirror spectrum about carrier? NO, YES	NO			enum	
GainImbalance	Gain imbalance, Q vs I	0.0		dB	real	(-∞, ∞)
PhaseImbalance	Phase imbalance, Q vs I	0.0		deg	real	(-∞, ∞)
I_OriginOffset	I origin offset (percent)	0.0			real	(-∞, ∞)
Q_OriginOffset	Q origin offset (percent)	0.0			real	(-∞, ∞)
IQ_Rotation	IQ rotation	0.0		deg	real	(-∞, ∞)

Advanced Design System 2008

SamplesPerChip	Samples per chip	8	S		int	[2, 32]
RRC_FilterLength	RRC filter length (chips)	12			int	[2, 128]
MidambleAllocScheme	Midamble allocation scheme: UE_Specific, Common, Default	Common			enum	
BasicMidambleID	Basic midamble index	0			int	[0, 127]
MidambleID	Midamble index	1			int	[1, K]
MaxMidambleShift	Max midamble shift	16	K		int	{2, 4, 6, 8, 10, 12, 14, 16}
SpreadCode	Spread code index	1			int	[1, 8]
ActiveTimeslot	Slot index: TS1, TS2, TS3, TS4, TS5, TS6	TS2			enum	

Pin Outputs

Pin	Name	Description	Signal Type
1	RF	RF output	timed
2	I	I symbols	real
3	Q	Q symbols	real

Notes/Equations

1. This TD-SCDMA signal source generates a 12.2 kbps uplink RF signal with one dedicated physical channel (DPCH) and one uplink pilot channel (UpPCH). The index of the basic synchronization code is set to 0 in the UpPCH. The RF signal has a chip rate of 1.28 MHz. The uplink is from the user equipment to the base station. To use this source, RF carrier frequency (FCarrier) and power (Power) must be set. RF impairments can be introduced by setting the ROut, RTemp, MirrorSpectrum, GainImbalance, PhaseImbalance, I_OriginOffset, Q_OriginOffset, and IQ_Rotation parameters. TD-SCDMA signal characteristics can be specified by setting the RRC_FilterLength, MidambleAllocScheme,

BasicMidambleID, MidambleID, MaxMidambleShift, SpreadCode, and ActiveTimeslot parameters.

Note
While the function of this model is similar to TDSCDMA_UL_RF, some parameter and output pins are different.

- This signal source includes a DSP section, RF modulator, and RF output resistance as illustrated in the following figure.

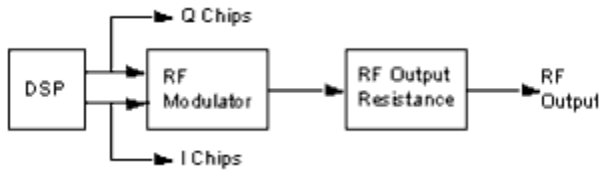

Signal Source Block Diagram

The ROut and RTemp parameters are used by the RF output resistance. The FCarrier, Power, MirrorSpectrum, GainImbalance, PhaseImbalance, I_OriginOffset, Q_OriginOffset, and IQ_Rotation parameters are used by the RF modulator. The remaining signal source parameters are used by the DSP block.

The RF output from the signal source is at the frequency specified (FCarrier), with the specified source resistance (ROut) and with power (Power) delivered into a matched load of resistance ROut. The RF signal has additive Gaussian noise power set by the resistor temperature (RTemp).

The I and Q outputs are baseband outputs with zero source resistance and contain the unfiltered I and Q chips available at the RF modulator input. Because the I And Q outputs are from the inputs to the RF modulator, the RF output signal has a time delay relative to the I and Q chips. This RF time delay (RF_Delay) is related to parameter value for RRC_FilterLength.

$$RF_Delay = RRC_FilterLength / (1.28e6) / 2sec.$$

- The RF power delivered into a matched load with resistance ROut is the average power delivered in the subframe time slot specified by parameter ActiveTimeslot. This is not the average subframe power (which is less). The following figure shows the RF envelope for one subframe with 10 dBm RF power delivered in time slot 2 (ActiveTimeslot = TS2).

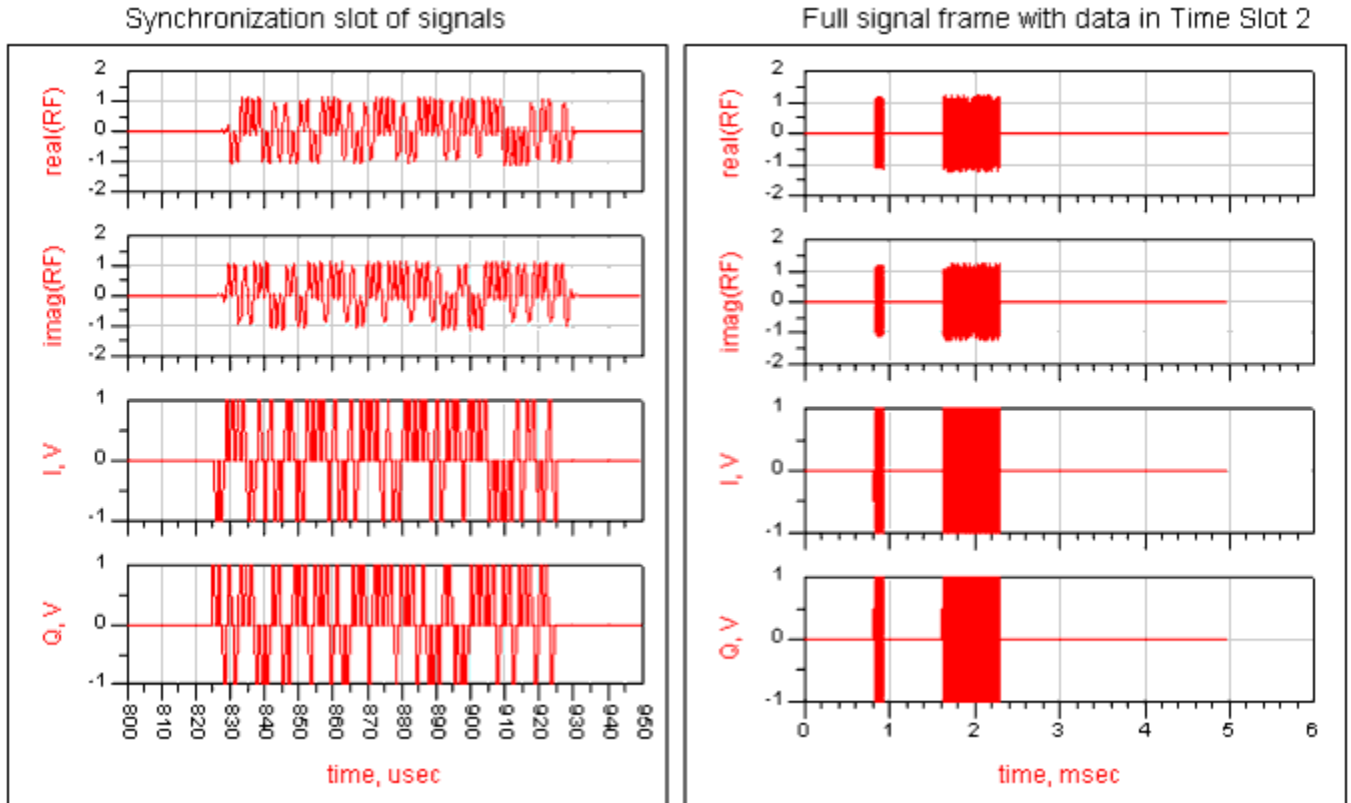

Source Power

- This TD-SCDMA uplink signal source model is compatible with Agilent Signal Studio software option 411 for transmission test.

Details regarding Signal Studio for TD-SCDMA are included at the website

<http://www.agilent.com/find/signalstudio>]

Note

There are two standards for TD-SCDMA systems: the international standard is called the 3GPP NTDD standard; the China national standard is called the TD-SCDMA TSM standard. This partially-coded TD-SCDMA signal source in ADS is based on the 3GPP NTDD standard. The Agilent TD-SCDMA signal studio signal source is based on the TD-SCDMA TSM standard. For TD-SCDMA transmission tests, this partially-coded TD-SCDMA signal source in ADS is compatible with the Agilent Signal Studio signal source.

- In the TD-SCDMA signal frame structure, one frame consists of two subframes. Each subframe consists of 7 time slots (TS), and one downlink pilot time slot (DwPTS), one guard period (GP) and one uplink pilot time slot (UpPTS). Each time slot can transmit DPCH signals. One subframe is composed of 6400 chips. Because the chip rate is 1.28 MHz, the subframe has a 5msec duration. The subframe structure is illustrated in the following figure.

For example, one DPCH signal is transmitted in TS2 as illustrated in the following figure. The DPCH bits are modulated by QPSK and spread by Walsh code of length 8 then transmitted in the slot. The DPCH signal is composed of 164 coded information bits ($164 \times 8/2$ chips), 8 bits ($8 \times 8/2$ chips) for transport format combination indicator (TFCI), 144 chips for midamble sequence, 2 bits ($2 \times 8/2$ chips) for transmitter power control and 2 bits ($2 \times 8/2$ chips) reserved (TPC and Reserved) plus 16 chips for GP. The total chips for the subframe is composed of 7 time slots plus 96 chips for DwPTS, 96 chips for GP and 160 chips for UpPTS and summarized as $(164 \times 4 + 8 \times 4 + 144 + 2 \times 4 + 2 \times 4 + 16) \times 7 + 160 + 96 \times 2 = 6400$ chips.

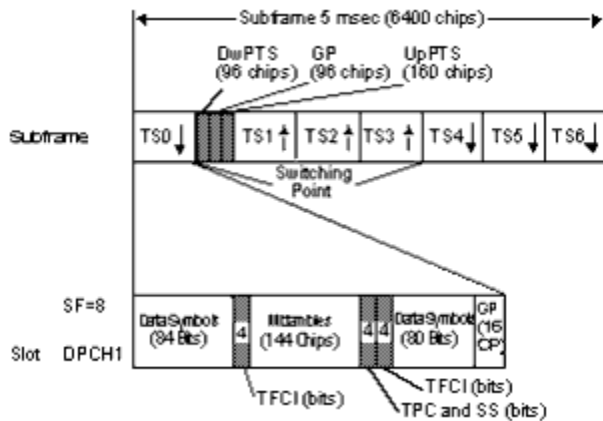

Subframe Structure of 12.2 kbps Uplink Channel

6. Parameter Details

- The ROut parameter is the RF output source resistance.
- The RTemp parameter is the RF output source resistance temperature in Celsius and sets the noise density in the RF output signal to $(k(RTemp+273.15))$ Watts/Hz, where k is Boltzmann's constant.
- The FCarrier parameter is the RF output signal frequency.
- The Power parameter is the RF output signal power. The Power of the signal is defined as the average power delivered in the subframe time slot specified by parameter ActiveTimeslot. See [note 3](#) for details.
- The MirrorSpectrum parameter is used to mirror the RF_out signal spectrum about the carrier. This is equivalent to conjugating the complex RF envelope voltage.

Depending on the configuration and number of mixers in an RF transmitter, the RF output signal from hardware RF generators can be inverted. If such an RF signal is desired, set this parameter to YES.

- The GainImbalance, PhaseImbalance, I_OriginOffset, Q_OriginOffset, and IQ_Rotation parameters are used to add certain impairments to the ideal output RF signal. Impairments are added in the order described here.

The unimpaired RF I and Q envelope voltages have gain and phase imbalance applied. The RF is given by:

$$V_{RF}(t) = A \left(V_I(t) \cos(\omega_c t) - g V_Q(t) \sin \left(\omega_c t + \frac{\phi \pi}{180} \right) \right)$$

where A is a scaling factor based on the Power and ROut parameters specified by the user, $V_I(t)$ is the in-phase RF envelope, $V_Q(t)$ is the quadrature phase RF envelope, g is the gain imbalance

$$g = 10^{\frac{\text{GainImbalance}}{20}}$$

and, ϕ (in degrees) is the phase imbalance.

Next, the signal $V_{RF}(t)$ is rotated by IQ_Rotation degrees. The I_OriginOffset and Q_OriginOffset are then applied to the rotated signal. Note that the amounts specified are percentages with respect to the output rms voltage. The output rms voltage is given by $\text{sqrt}(2 \times \text{ROut} \times \text{Power})$.

- The SamplesPerChip parameter sets the number of samples in a chip. The default value of this parameter is set to 8 to display settings according to the 3GPP NTDD. It can be set to a larger value for a simulation frequency bandwidth wider than 8×1.28 MHz. It can be set to a smaller value for faster simulation; however, this will result in lower signal fidelity. If SamplesPerChip = 8, the simulation RF bandwidth is larger than the signal bandwidth by a factor of 8 (e.g., simulation RF bandwidth = 8×3.84 MHz)
- The RRC_FilterLength parameter shows root raised-cosine (RRC) filter length in chips.

The default value of this parameter is set to 12 to transmit TD-SCDMA downlink signals in time and frequency domains based on the 3GPP NTDD standard [1-3]. It can be set to a smaller value for faster simulation; however, this will result in lower signal fidelity.

- MidambleAllocScheme is used to select the midamble allocation scheme. There are three midamble allocation schemes based on the 3GPP NTDD standard [1,2].
 UE specific midamble allocation: a UE specific midamble for uplink and downlink is explicitly assigned by higher layers
 Default midamble allocation: the midamble for uplink and downlink is assigned by layer 1 depending on associated channelization code.
 Common midamble allocation: the midamble for downlink is allocated by layer 1 depending on the number of channelization codes currently present in the downlink time slot.
 To set the MidambleAllocScheme parameter based on the 3GPP NTDD standard [1], related parameters must be set as stated here:
 if MidambleAllocScheme= UE_Specific, the BasicMidambleID, MaxMidambleShift and MidambleID parameters are used to specify which midamble is exported.
 if MidambleAllocScheme=Common, only the BasicMidambleID, MaxMidambleShift are used to specify which midamble is exported; the MidambleID parameter is ignored.
 if MidambleAllocScheme=Default, only the BasicMidambleID, MaxMidambleShift are used to specify which midamble is exported, the MidambleID parameter is ignored.
- BasicMidambleID sets the basic midamble code ID. The basic midamble code is used for training sequences for uplink and downlink channel estimation, power measurements and maintaining uplink synchronization. There are 128 different sequences; BasicMidambleID can be set from 0 to 127. In Signal Studio, Basic Midamble ID code has the same meaning as this parameter.
- MaxMidambleShift is the maximum number of different midamble shifts in a cell that can be determined by maximum users in the cell for the current time slot.
- MidambleID sets the index of midambles for DPCH. Midambles of different users active in the same cell and the same time slot are cyclically shifted versions of one basic midamble code.
 Let $P = 128$, the length of basic midamble and $K = \text{MaxMidambleShift}$, then

$$W = \left\lfloor \frac{P}{K} \right\rfloor$$
, is the shift between midambles and $\lfloor x \rfloor$ denotes the largest number less than or equal to x .
 MidambleID range is from 1 to MaxMidambleShift.
 MidambleID and MaxMidambleShift together correspond to the Midamble Offset parameter in Signal Studio for Timeslot setup. Midamble Offset = MidambleID \times W.
- SpreadCode sets the spread code index for the DPCH. For this signal source, the spreading factor is 8. In Signal Studio, Channelization code for Time slot setup has the same meaning of SpreadCode.
- ActiveTimeslot parameter is used to select which slot signal in the subframe will be transmitted.

References

1. 3GPP TS 25.221, 3rd Generation Partnership Project; Technical Specification Group Radio Access Network; Physical channels and mapping of transport channels onto physical channels (TDD) (Release 4), version 4.5.0, Dec., 2001.
http://www.3gpp.org/ftp/Specs/2001-12/Rel-4/25_series/25221-430.zip
2. 3GPP TS 25.223, 3rd Generation Partnership Project; Technical Specification Group Radio Access Network; Spreading and modulation (TDD) (Release 4), version 4.3.0, Dec., 2001.
http://www.3gpp.org/ftp/Specs/2001-12/Rel-4/25_series/25223-430.zip
3. 3GPP TS 25.102, 3rd Generation Partnership Project; Technical Specification Group Radio Access Network; UE

Radio transmission and Reception (TDD) (Release 4), version 4.5.0, June 2002.
http://www.3gpp.org/ftp/Specs/2002-06/Rel-4/25_series/25102-450.zip

TDSCDMA_OCNS

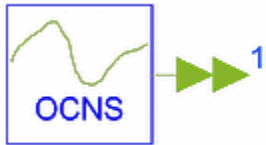

Description Flexible OCNS generator
 Library TDSCDMA, Signal Sources
 Class SDFTDSCDMA_OCNS

Parameters

Name	Description	Default	Type	Range
ModType_PA	type of modulation corresponding to allocated physical channels	0	int array	[0, 1]
SpreadFactor_PA	spreading factor corresponding to allocated physical channels	1	int array	{1, 2,4,8,16}
SpreadCode_PA	index of OVFSF code corresponding to allocated physical channels	1	int array	[1, SpreadFactor]
BasicMidambleID	index of basic midamble	1	int	[0, 127]
K	maximum number of midamble shifts in a cell	16	int	{2, 4,6,8,10,12,14,16}
MidambleID_PA	index of midamble corresponding to allocated physical channels	1	int array	[1, K]
Gain_PA	gain setting array corresponding to	1.0	real array	(0, ∞)

Advanced Design System 2008

	allocated physical channels			
SlotIndex	allocated active slots configuration	1	int	[0, 6]

Pin Outputs

Pin	Name	Description	Signal Type
1	DataOut	output data	multiple complex

Notes/Equations

1. This model is a flexible orthogonal channel noise simulator. The number of DPCH is determined by the dimension of ModType_SA. However, the dimensions of all array parameter must be the same.
Each firing, 6400 DataOut tokens are produced.
2. SlotIndex indicates the index of slot in which the physical channel will be transmitted.
3. ModType_PA is the modulation mapping scheme of the data bits, 0 for QPSK, 1 for 8PSK.
4. The elements of SpreadFactor_PA and SpreadCode_PA are the spreading factor and index of spreading code for each physical channel.
5. The index of scramble code is the same as BasicMidambleID.
6. The midamble of each physical channel is determined by UE_Specific based on K and MidambleID_PA settings.
7. Gain_PA determines the gain of each physical channel.

References

1. 3GPP TS 25.221, 3rd Generation Partnership Project; Technical Specification Group Radio Access Network; Physical channels and mapping of transport channels onto physical channels (TDD) (Release 4), version 4.5.0, June 2002.
2. 3GPP TS 25.223, 3rd Generation Partnership Project; Technical Specification Group Radio Access Network; Spreading and modulation (TDD) (Release 4), version 4.5.0, June 2002.
3. 3GPP TS 25.105, 3rd Generation Partnership Project; Technical Specification Group Radio Access Network; BS Radio transmission and Reception (TDD) (Release 4), version 4.5.0, June 2002.

TDSCDMA_SlotSrc

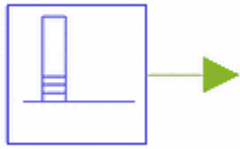

Description Flexible SubFrame generator
 Library TDSCDMA, Signal Sources
 Class SDFTDSCDMA_SlotSrc
 Derived From TDSCDMA_CCTrCH_MuxBase

Parameters

Name	Description	Default	Type	Range
Link	link selection: Downlink, Uplink	Uplink	enum	
SlotIndex	allocated active slots configuration	1	int	[0, 6]
ChannelState_PA	active status for each slots	1	int array	{0, 1}
ModType_PA	type of modulation corresponding to allocated physical channels	0	int array	{0, 1}
SpreadFactor_PA	spreading factor corresponding to allocated physical channels	16	int array	{1, 2,4,8,16}
SpreadCode_PA	index of OVSF code corresponding to allocated physical channels	16	int array	[1, SpreadFactor]
BasicMidambleID	index of basic midamble	1	int	[0, 127]
K	maximum number of midamble shifts in a cell	16	int	{2, 4,6,8,10,12,14,16}
UserID_PA	user id for each DPCH in a slot	1	int array	[1, K]
Gain_PA	gain setting array corresponding to allocated physical	1.0	real array	(0, ∞)

	channels			
--	----------	--	--	--

Pin Outputs

Pin	Name	Description	Signal Type
1	DataOut	output data	complex

Notes/Equations

1. This model is a flexible channel signal simulator that generates signals for several physical channels in one specified time slot. The number of slots is determined by SlotIndex. The physical channels are specified by 1s in the ChannelState_PA parameter array; the maximum number of physical channels in one timeslot is 16. Dimensions of all other array parameters are determined by ChannelState_PA.
2. The output of this model is a subframe with one time slot data filled. Each firing, 6400 DataOut tokens are produced. Data of each physical channel is randomly generated, modulated, spread and scrambled.
3. In the TD-SCDMA signal frame structure, one frame consists of two subframes. The subframe structure is illustrated in the following figure; each subframe consists of 7 time slots (TS), and one downlink pilot time slot (DwPTS), one guard period (GP) and one uplink pilot time slot (UpPTS). Each time slot transmits physical channel signals. Each physical channel signal is composed of 704 chips for data, TFCI and TPC, 144 chips midamble and 16 chips guard period. The following figure illustrates an output subframe with n physical channels in TS0.

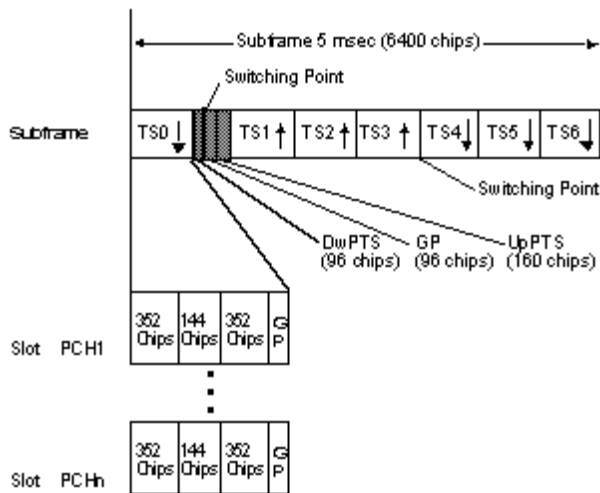

Example of a SubFrame Structure

4. Link sets uplink/downlink for each slot; the link is limited to downlink in TS0.
5. SlotIndex indicates the slot index in which the physical channels will be transmitted.
6. ChannelState_PA is an integer array indicating the on/off status of each physical channel; when the element of the parameter is set to 1, the corresponding physical channel is active, otherwise 0 for inactive.
7. ModType_PA determines the modulation mapping scheme of the data bits: 0 for QPSK and 1 for 8PSK.
8. After modulation, data is spread with corresponding spreading codes. The spreading factor of each physical channel is determined by SpreadFactor_PA, while the spreading code index is set by SpreadCode_PA.

9. BasicMidambleID sets the basic midamble code ID. There are 128 different sequences. Hence, BasicMidambleID can be set from 0 to 127.
10. UserID_PA sets the indices of midambles for the each PCH. Midambles of different users active in the same cell and the same time slot are cyclically shifted versions of one basic midamble code.
Let

$P = 128$, the length of basic midamble; set K as the max midamble shift,

then

$W = \left\lfloor \frac{P}{K} \right\rfloor$ is the shift between midambles

$\lfloor x \rfloor$ denotes the largest number less or equal to x .

11. The midamble allocation schemes are based on 3GPP NTDD standard [1,2].
 - UE specific midamble allocation: a UE specific midamble for downlink and uplink is explicitly assigned by higher layers
 - Default midamble allocation: the midamble for downlink and uplink is assigned by layer 1 depending on associated channelization code.
 - Common midamble allocation: the midamble for downlink is allocated by layer 1 depending on the number of channelization codes currently present in the downlink time slot.
In this model, the UE_Specific midamble allocation scheme is used to generate midamble chips based on K and UserID_PA settings.
12. The index of scramble code is the same as BasicMidambleID.
13. Gain_PA determines the gain of each physical channel.

References

1. 3GPP TS 25.221, 3rd Generation Partnership Project; Technical Specification Group Radio Access Network; Physical channels and mapping of transport channels onto physical channels (TDD) (Release 4), version 4.5.0, June 2002.
2. 3GPP TS 25.223, 3rd Generation Partnership Project; Technical Specification Group Radio Access Network; Spreading and modulation (TDD) (Release 4), version 4.5.0, June 2002.

TDSCDMA_UL_RF



Description TDSCDMA uplink RF signal source
 Library TDSCDMA, Signal Sources
 Class TSDFTDSCDMA_UL_RF

Parameters

Name	Description	Default	Unit	Type	Range
ROut	output resistance	DefaultROut	Ohm	real	(0, ∞)
FCarrier	carrier frequency	1900MHz	Hz	real	(0, ∞)
Power	modulator output power	0.1W	W	real	(0, ∞)
SlotIndex	index of slot	2		int	[1, 6]
MidambleAllocScheme	midamble allocation scheme: UE_Specific, Default	Default		enum	
BasicMidambleID	index of basic midamble	0		int	[0, 127]
K	maximum number of midamble shifts in a cell	16		int	{2, 4,6,8,10,12,14,16}
MidambleID	index of midamble	1		int	[1, K]
SpreadCode	index of spread code	1		int	[1, 8]
SamplesPerSymbol	samples per symbol period	8		int	[1, 32]
FilterLength	length of raised cosine filters in number of symbols	16		int	(0, ∞)

Pin Outputs

Advanced Design System 2008

Pin	Name	Description	Signal Type
1	OutRF	output signals	timed
2	TFCI	transport format combination indicator bits	int
3	SS	information bits for uplink synchronization control	int
4	TPC	transmit power control bits	int
5	Data	input information data bits	int

Notes/Equations

1. This TD-SCDMA signal source generates a 12.2 kbps uplink (UL) RF signal with one dedicated physical channel (DPCH).
2. To use this source, one typically needs to only set the RF carrier frequency (FCarrier) and power (Power). Specific TD-SCDMA signal characteristics may be set, as may be required by a project system engineer, by setting parameters FilterLength, MidambleAllocScheme, SlotIndex, BasicMidambleID, MidambleID, K and SpreadCode.
3. This signal source is composed of a DSP section, RF modulator and output source resistor as shown in the following figure.
The RF output from the signal source is at the frequency specified (FCarrier), with the specified source resistance (ROut) and power (Power).

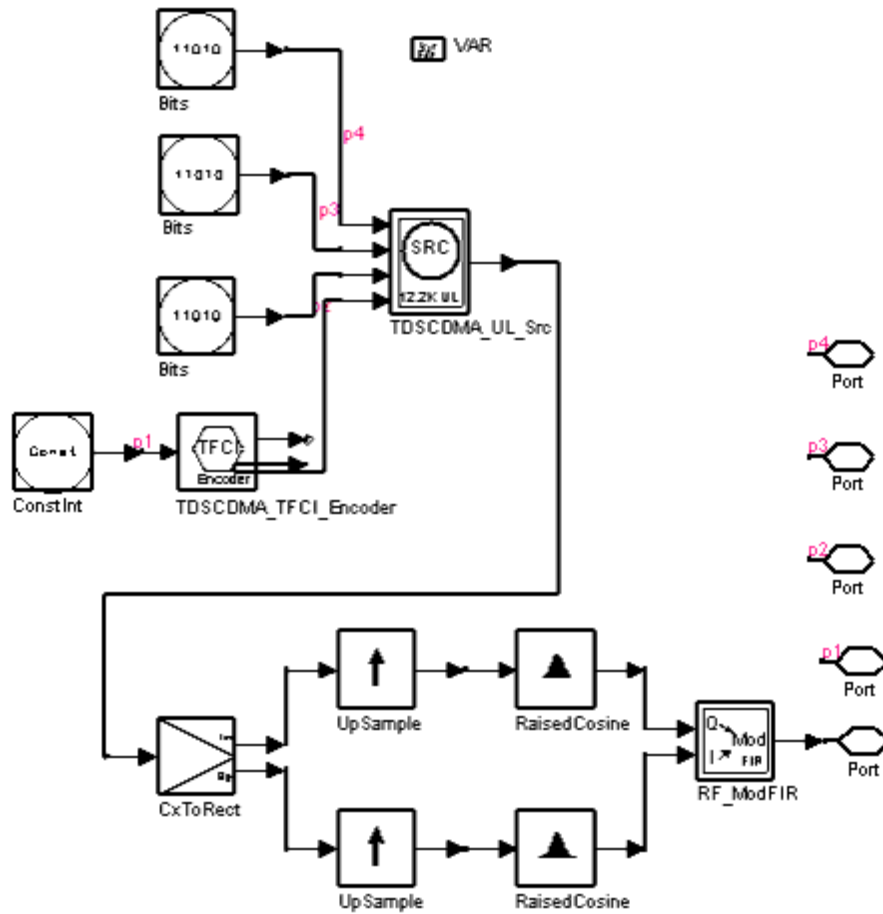

TDSCDMA_UL_RF Schematic

4. This TD-SCDMA uplink signal source model is compatible with Agilent Signal Studio software option 411 for transmitter test. Details regarding Signal Studio for TD-SCDMA are included at the website <http://www.agilent.com/find/signalstudio>. This partially coded TD-SCDMA signal source per 3GPP NTDD is almost identical to TD-SCDMA TSM defined for Signal Studio.
5. In the TD-SCDMA signal frame structure, one frame consists of two subframes. The subframe structure is illustrated in the following figure. As can be seen, each subframe consists of 7 time slots (TS), and one downlink pilot time slot (DwPTS), one guard period (GP) and one uplink pilot time slot (UpPTS). Each time slot can transmit DPCH signals

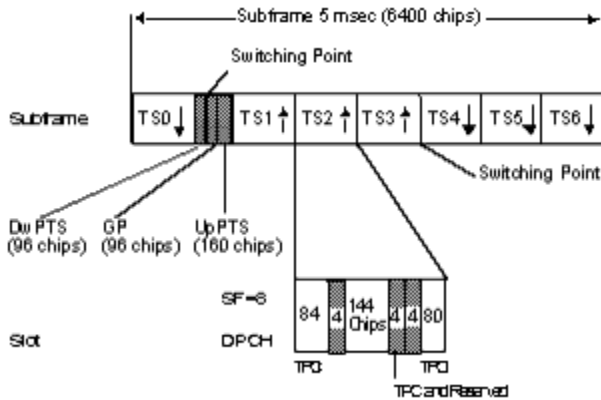

SubFrame Structure of 12.2 kbps Uplink Channel

6. In general, changing the TD-SCDMA uplink source parameters settings from their default value will affect various transmitter measurements including Power, Envelope, CCDF, and Spectrum.

7. Parameter details

- SamplesPerSymbol sets the number of samples in a chip. The default value of this parameter is set to 8 to display results properly under settings based on 3GPP NTDD standard. Set this value to a larger value if a simulation frequency bandwidth for this signal wider than 8×1.28 MHz is desired. Set this value to a smaller value for faster simulation times, but at the cost of lower signal fidelity.
- FilterLength shows root raised-cosine (RRC) filter length in chips. The default value of this parameter is set to 12 to transmit TD-SCDMA uplink signals in both time and frequency domains according to 3GPP NTDD standard [1-3]. Set this value to a smaller value for faster simulation times, but at the cost of lower signal fidelity.
- MidambleAllocScheme is used to select the midamble allocation scheme. There are three midamble allocation schemes based on 3GPP NTDD standard [1,2].
 UE_Specific: a UE-specific midamble allocation for downlink and uplink is explicitly assigned by higher layers.
 Default: the midamble allocation for downlink and uplink is assigned by layer 1 depending on associated channelization code.
 Common: the downlink midamble allocation is assigned by layer 1 depending on the number of channelization codes currently present in the downlink time slot.
 To set MidambleAllocScheme parameter based on 3GPP NTDD standard [1], related parameters must also be set:
 if MidambleAllocScheme = UE_Specific, the BasicMidambleID, K and MidambleID parameters are used to specify which midamble is exported.
 if MidambleAllocScheme = Common, only the BasicMidambleID, K are used to specify which midamble is exported, the MidambleID parameter is ignored.
 if MidambleAllocScheme = Default, only the BasicMidambleID, K are used to specify which midamble is exported, the MidambleID parameter is ignored.

- SlotIndex parameter is used to select which slot signal in the subframe will be transmitted.
- BasicMidambleID sets the basic midamble code ID. The basic midamble code is used for training sequences for uplink and downlink channel estimation, power measurements and maintaining uplink synchronization. There are 128 different sequences; BasicMidambleID can be set from 0 to 127. In Signal Studio, Basic Midamble ID code has the same meaning as this parameter.

- K is the maximum number of different midamble shifts in a cell that can be determined by maximum users in the cell for current time slot.
- MidambleID sets the index of midambles for DPCH. Midambles of different users active in the same cell and the same time slot are cyclically shifted versions of one basic midamble code.

Let $P = 128$, the length of basic midamble, then $W = \left\lfloor \frac{P}{K} \right\rfloor$, is the shift between midambles and $\lfloor x \rfloor$ denotes

the largest number less or equal to x . MidambleID range is from 1 to K.

MidambleID and K together correspond to parameter of Midamble Offset in Signal Studio for Timeslot setup.

Midamble Offset = MidambleID \times W.

- SpreadCode sets the spread code index for the DPCH. For this signal source, the spreading factor is 8. In Signal Studio, Channelization code for Time slot setup has the same meaning as SpreadCode.

References

1. 3GPP TS 25.102, 3rd Generation Partnership Project; Technical Specification Group Radio Access Network; UTRA(UE) TDD; Radio Transmission and Reception (Release 4), version 4.2.0.

TDSCDMA_UL_Src



Description TDSCDMA uplink signal source

Library TDSCDMA, Signal Sources

Class SDFTDSCDMA_UL_Src

Parameters

Name	Description	Default	Type	Range
SlotIndex	index of slot	2	int	[1, 6]
MidambleAllocScheme	midamble allocation scheme: UE_Specific, Default	Default	enum	
BasicMidambleID	index of basic midamble	0	int	[0, 127]
K	maximum number of	16	int	{2,

Advanced Design System 2008

	midamble shifts in a cell			4,6,8,10,12,14,16}
MidambleID	index of midamble	1	int	[1, K]
SpreadCode	index of spread code	1	int	[1, 8]

Pin Inputs

Pin	Name	Description	Signal Type
1	Data	input data	int
2	TFCI	transport format combination indicator bits	int
3	SS	information bits for uplink synchronization control	int
4	TPC	transmit power control bits	int

Pin Outputs

Pin	Name	Description	Signal Type
5	Output	output data	complex

Notes/Equations

1. This subnetwork generates an uplink signal source with 12.2 kbps that includes one DPCH. The schematic for this subnetwork is shown in the following figure.

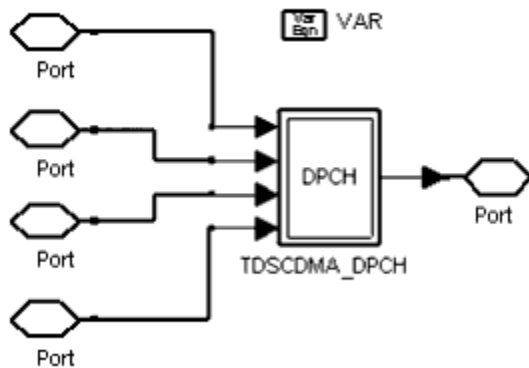

TDSCDMA_UL_Src Schematic

2. The frame structure is illustrated in the following figure.

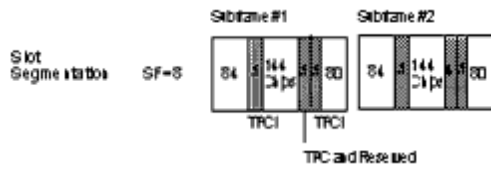

Frame Structure of 12.2 kbps UL Channel

References

1. 3GPP TS 25.221, 3rd Generation Partnership Project; Technical Specification Group Radio Access Network; Physical channels and mapping of transport channels onto physical channels (TDD) (Release 4), version 4.3.0, Dec., 2001.