



Agilent Technologies

ADS 2008
January 2008
Ultra-Wideband Design Library

Advanced Design System 2008

© Agilent Technologies, Inc. 2000-2008

395 Page Mill Road, Palo Alto, CA 94304 U.S.A.

No part of this manual may be reproduced in any form or by any means (including electronic storage and retrieval or translation into a foreign language) without prior agreement and written consent from Agilent Technologies, Inc. as governed by United States and international copyright laws.

Acknowledgments

Mentor Graphics is a trademark of Mentor Graphics Corporation in the U.S. and other countries. Microsoft®, Windows®, MS Windows®, Windows NT®, and MS-DOS® are U.S. registered trademarks of Microsoft Corporation. Pentium® is a U.S. registered trademark of Intel Corporation. PostScript® and Acrobat® are trademarks of Adobe Systems Incorporated. UNIX® is a registered trademark of the Open Group. Java™ is a U.S. trademark of Sun Microsystems, Inc. SystemC® is a registered trademark of Open SystemC Initiative, Inc. in the United States and other countries and is used with permission. MATLAB® is a U.S. registered trademark of The Math Works, Inc.. HiSIM2 source code, and all copyrights, trade secrets or other intellectual property rights in and to the source code in its entirety, is owned by Hiroshima University and STARC.

Errata The ADS product may contain references to "HP" or "HPEESOF" such as in file names and directory names. The business entity formerly known as "HP EEsof" is now part of Agilent Technologies and is known as "Agilent EEsof". To avoid broken functionality and to maintain backward compatibility for our customers, we did not change all the names and labels that contain "HP" or "HPEESOF" references.

Warranty The material contained in this document is provided "as is", and is subject to being changed, without notice, in future editions. Further, to the maximum extent permitted by applicable law, Agilent disclaims all warranties, either express or implied, with regard to this manual and any information contained herein, including but not limited to the implied warranties of merchantability and fitness for a particular purpose. Agilent shall not be liable for errors or for incidental or consequential damages in connection with the furnishing, use, or performance of this document or of any information contained herein. Should Agilent and the user have a separate written agreement with warranty terms covering the material in this document that conflict with these terms, the warranty terms in the separate agreement shall control.

Technology Licenses The hardware and/or software described in this document are furnished under a license and may be used or copied only in accordance with the terms of such license. Portions of this product include the SystemC software licensed under Open Source terms, which are available for download at <http://systemc.org/>. This software is redistributed by Agilent. The Contributors of the SystemC software provide this software "as is" and offer no warranty of any kind, express or implied, including without limitation warranties or conditions or title and non-infringement, and implied warranties or conditions merchantability and fitness for a particular purpose. Contributors shall not be liable for any damages of any kind including without limitation direct, indirect, special, incidental and consequential damages, such as lost profits. Any provisions that differ from this disclaimer are offered by Agilent only.

Restricted Rights Legend If software is for use in the performance of a U.S. Government prime contract or subcontract, Software is delivered and licensed as "Commercial computer software" as defined in DFAR 252.227-7014 (June 1995), or as a "commercial item" as defined in FAR 2.101(a) or as "Restricted computer software" as defined in FAR 52.227-19 (June 1987) or any equivalent agency regulation or contract clause. Use, duplication or disclosure of Software is subject to Agilent Technologies' standard commercial license terms, and non-DOD Departments and Agencies of the U.S. Government will receive no greater than Restricted Rights as defined in FAR 52.227-19(c)(1-2) (June 1987). U.S. Government users will receive no greater than Limited Rights as defined in FAR 52.227-14 (June 1987) or DFAR 252.227-7015 (b)(2) (November 1995), as applicable in any technical data.

Contents

- About UWB Design Library
- - WiMedia PHY specification
 - - MB-OFDM Transmitter for Physical Layer Block Diagram
 - Component Libraries
 - - Channel Coding Components
 - - Measurement Component
 - - Multiplex Components
 - - Receiver Components
 - - Signal Source Components
 - Glossary of Terms/References
- Channel Coding Components for Ultra-Wideband Design Library
- - UWB FCS
 - - Notes/Equations
 - - The schematic of subnetwork UWB_FCS
 - - The schematic of UWB_XOR
 - UWB Interleaver
 - - Notes/Equations
 - - References
 - UWB Puncturer
 - - Notes/Equations
 - - An example of the bit-stealing and bit-inserting procedure ($R=11/32$)
 - - An example of the bit-stealing and bit-inserting procedure ($R=1/2$)
 - - An example of the bit-stealing and bit-inserting procedure ($R=5/8$)
 - - An example of the bit-stealing and bit-inserting procedure ($R=3/4$)
 - - References
 - UWB Scrambler
 - - Notes/Equations
 - - - PLCP frame format
 - - Scrambler seed selection
 - - References
- Measurement Components for Ultra-Wideband Design Library
- - UWB MBOFDM EVM
 - Notes/Equations
 - - Relationship of SearchLength, MeasurementOffset and MeasurementInterval
 - References
 - UWB RF CCDF
 - - Notes/Equations
 - - UWB_RF_CCDF schematic
 - - References
- Multiplex Components for Ultra-Wideband Design Library
- - UWB DemuxDataPLCP
 - - Notes/Equations
 - - References
 - UWB DemuxOFDMSym
 - - Notes/Equations
 - - References

- UWB GuardGain
 - - Notes/Equations
 - - The schematic of subnetwork UWB_GuardGain
 - References
- UWB MuxFrame
 - - Notes/Equations
 - - The schematic of subnetwork UWB_MuxFrame
 - References
- UWB MuxHeadPSDU
 - - Notes/Equations
 - - The schematic of UWB_MuxHeadPSDU
 - PLCP frame format
 - References
- UWB MuxOFDMSym
 - - Notes/Equations
 - - The schematic of subnetwork UWB_GuardGain
 - References
- UWB TimeSpreading
 - - Notes/Equations
 - References
- UWB TimeSpreadingMR
 - - Notes/Equations
 - References
- Receiver Components
 - UWB ChEstimator
 - - Notes/Equations
 - - UWB_ChEstimator Schematic
 - References
 - UWB Demapper
 - - Notes/Equations
 - References
 - UWB DemuxFrame
 - - Notes/Equations
 - References
 - UWB FrameSync
 - - Notes/Equations
 - - PLCP frame format.
 - Block diagram of the PLCP preamble
 - Block diagram of PLCP preamble construction
 - Time Frequency Codes and associated Preamble Patterns
 - Cover sequence for standard preamble
 - Cover sequence for burst preamble
 - References
 - UWB FreqSync
 - - Notes/Equations
 - - UWB_FreqSync Schematic
 - References
 - UWB PhaseTracker
 - - Notes/Equations
 - References

- UWB Receiver
 - - Notes/Equations
 - UWB_Receiver Schematic
 - References
- UWB Receiver FH RF
 - - Notes/Equations
 - UWB_Receiver_FH_RF Schematic
 - References
- UWB Receiver RF
 - - Notes/Equations
 - UWB_Receiver_RF Schematic
 - References
- Signal Source Components
 - UWB Freq Hopping
 - - Notes/Equations
 - The schematic of subnetwork UWB_Freq_Hopping
 - Frequency allocation diagram
 - References
 - UWB Mapper
 - - Notes/Equations
 - References
 - UWB PHY Header
 - - Notes/Equations
 - The schematic of subnetwork UWB_PHY_Header
 - PHY Header bit assignment
 - References
 - UWB_PLCP_Header
 - - Notes/Equations
 - The schematic of subnetwork UWB_PLCP_Header
 - Block diagram of PLCP header construction
 - CCITT CRC-16 block diagram
 - References
 - UWB SignalSource
 - - Notes/Equations
 - The schematic of subnetwork UWB_SignalSource
 - PLCP frame format.
 - References
 - UWB SignalSource RF
 - - Notes/Equations
 - The schematic of subnetwork UWB_SignalSource_RF
 - References
 - UWB Source FH RF
 - - Notes/Equations
 - The schematic of subnetwork UWB_Source_FH_RF
 - References
- UWB Receiver Test & Verification Design Examples
 - Introduction
 - UWB MB-OFDM Receiver Minimum Input Level Sensitivity Measurement:
 - - Features
 - Description

- - UWB_OFDM_RxSensitivity.dsn
- Specification requirements
- Simulation Results
- - UWB_OFDM_RxSensitivity.dds
- Benchmark
- UWB MB-OFDM PER vs.Range in AWGN Environment:
 - - - Features
 - Description
 - - UWB_OFDM_PER_vs_Rang_AWGN.dsn
 - Specification Requirement
 - - PER vs. Range in AWGN environment
 - Simulation Results
 - - UWB_OFDM_PER_vs_Rang_AWGN.dds
 - Benchmark
 - References:
- UWB MB-OFDM PER vs.Range in Fading Environment:
 - - Features
 - Description
 - - UWB_OFDM_PER_vs_Range_Fading.dsn
 - Simulation Results
 - - UWB_OFDM_PER_vs_Range_Fading.dds
 - Benchmark
 - References:
- UWB MB-OFDM Receiver Performance with ADC Effect:
 - - Features
 - - Description
 - - UWB_OFDM_ADC_Effect.dsn
 - Simulation Results
 - - UWB_OFDM_ADC_Effect.dds
 - Benchmark
 - References:
- UWB MB-OFDM Receiver Performance with WLAN 11a Interferer:
 - - Features
 - Description
 - - UWB_OFDM_Rx_with_WLAN_11a_Interferer.dsn
 - Simulation Results
 - - UWB_OFDM_Rx_with_WLAN_11a_Interferer.dds
 - Benchmark
 - References:
- UWB MB-OFDM Receiver Performance with WiMax Interferer:
 - - Features
 - Description
 - - UWB_OFDM_Rx_with_WiMax_Interferer.dsn
 - Simulation Results
 - - UWB_OFDM_Rx_with_WiMax_Interferer.dds
 - Benchmark
 - References:
- UWB Transmitter Design Examples
 - Introduction
 - Example of Encoding a Packet for the Multi-band OFDM PHY

- - Features
 - Description
 - UWB_OFDM_Demo Schematic
 - Simulation Results
 - PLCP preamble
 - PLCP Header and Frame payload
 - Benchmark
 - References
- Complementary Cumulative Distribution Function Measurement
- - Features
 - Description
 - UWB_OFDM_TxCCDF.dsn Schematic
 - Simulation Results
 - CCDF of UWB_Source_FH_RF
 - Waveform of UWB_Source_FH_RF
 - Benchmark
 - References
- Error Vector Magnitude without Reference Signal
- - Features
 - Description
 - UWB_EVM Schematic
 - Simulation Results
 - Measurement results
 - Benchmark
 - References
- Transmit Spectrum Measurement for UWB MB-OFDM System
- - Features
 - Description
 - Transmit spectrum mask
 - Schematics
 - UWB_OFDM_TxSpectrum.dsn Schematic
 - Simulation Results
 - Power Spectrum Density
 - Power spectrum at 1MHz RBW
 - Hopped LO vs. Time
 - Hopped signal vs. Time
 - Baseband signal vs. Time
 - Benchmark
 - References

About UWB Design Library

The Agilent EEsof UWB Design Library is for the WiMedia Multi-Band OFDM market. It follows WiMedia Multiband OFDM Physical Layer Specification Release 1.1. This design library focuses on the physical layer of UWB systems and is

intended to be a baseline system for designers to get an idea of what a nominal or ideal system performance would be. Evaluations can be made regarding degraded system performance due to system impairments that may include nonideal component performance.

WiMedia PHY specification

WiMedia physical-layer specification employs frequency hopping of 528-MHz-wide orthogonal frequency-division-multiplexing (OFDM) channels. It uses 122 carriers or "tones", of which 100 carry quadrature phase-shift keying modulated data. A basic 640-Mb/s data rate combined with FEC rates of 11/32, 1/2, 5/8 or 3/4, and frequency-spreading ratios of 1, 2 or 4 on the carriers, results in data rates of 53.3, 80, 106.7, 160, 200, 320 and 480 Mb/s. Multiple modes of operation include a mandatory three-band mode (mode 1) operating between 3.1 and 5 GHz. Before any two MB-OFDM radios can communicate in their high-rate OFDM mode, they must first synchronize using a time-based sequence.

The MB-OFDM transmitter block diagram is shown in the following figure.

Major specifications for the MB-OFDM) physical layer are listed in the following table.

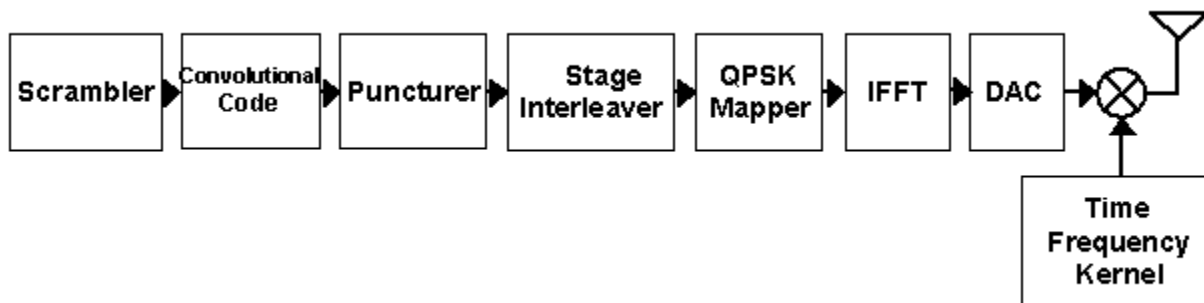

MB-OFDM Transmitter for Physical Layer Block Diagram

Specification	Settings
Information data rate	53.3, 80, 106.7, 160, 200, 320, 400 and 480 Mb/s
Modulation	QPSK/DCM OFDM
Error correcting code	K = 7 (64 states) convolutional code
Coding rate	1/3, 11/32, 1/2, 5/8, 3/4
Number of data subcarriers	100
Number of defined pilot subcarriers	10

Number of guard subcarriers	12
Number of total subcarriers used	122
Δ_F	4.125 MHz (= 528 MHz/128)
TFFT: IFFT/FFT period	242.42 ns ($1/\Delta_F$)
TZP: Zero pad duration	70.08 ns (= 37/528 MHz)

Component Libraries

The UWB Design Library is organized by library according to the types of behavioral models and subnetworks.

Channel Coding Components

The channel coding models provide channel coding, scrambling and interleaving in the transmitter end, and channel decoding and de interleaving in the receiving end.

- UWB_FCS: UWB frame check sequence
- UWB_Interleaver: UWB interleaver or de-interleaver
- UWB_Puncturer: UWB puncturer or de-puncturer
- UWB_Scrambler: UWB scrambler

Measurement Component

The measurement models provide basic measurements.

- UWB_RF_CCDF: UWB CCDF measurement
- UWB_EVM: UWB EVM measurement without frequency hopping
- UWB_FH_EVM: UWB EVM measurement with frequency hopping

Multiplex Components

This library provides 9 models for use with MB-OFDM systems.

- UWB_ConjCombiner: UWB conjugation combiner
- UWB_Conjugate: UWB conjugator
- UWB_DemuxDataPLCP: UWB PLCP and PSDU demultiplexer
- UWB_DemuxOFDMSym: UWB OFDM symbol demultiplexer
- UWB_MuxFrame: UWB frame multiplexer
- UWB_MuxHeadPSDU: UWB PLCP header and PSDU multiplexer
- UWB_MuxOFDMSym: UWB OFDM symbol multiplexer
- UWB_TimeSpreadingMR: UWB time-domain spreader or despreader with maximum ratio combination
- UWB_TimeSpreadingMR: UWB time-domain spreader or despreader

Receiver Components

This library provides models for use with UWB MB-OFDM receiver.

- UWB_ChEstimator: UWB channel estimator
- UWB_DemuxFrame: frame de-multiplexer with frequency offset compensation, cyclic prefix and guard interval removed
- UWB_FrameSync: UWB coarse timing synchronizer
- UWB_FreqSync: UWB frequency synchronizer
- UWB_PhaseTracker: UWB phase tracker
- UWB_Receiver: UWB receiver
- UWB_Receiver_FH_RF: UWB RF frequency hopping receiver
- UWB_Receiver_RF: UWB RF receiver

Signal Source Components

This library provides models for use with UWB MB-OFDM signal source.

- UWB_Freq_Hopping: UWB frequency hopping synthesizer
- UWB_PHY_Header: UWB physical header generator
- UWB_SignalSource: UWB signal source
- UWB_SignalSource_RF: UWB RF signal source
- UWB_Source_FH_RF: UWB RF frequency hopping signal source
- UWB_TimeDomainSeq: UWB time domain synchronization sequence generator

Glossary of Terms/References

AWGN	addition white Gaussian noise
CCDF	complementary cumulative distribution function

CSMA/CA	carrier sense multiple access/collision avoidance
DS-UWB	direct-sequence UWB
DCM	dual carrier modulation
EVM	error vector magnitude
FEC	forward error correction
FFT	fast fourier transform
IEEE	Institute of Electrical and Electronic Engineering
IFFT	inverse fast fourier transform
MAC	medium access control
MB-OFDM	multi band orthogonal frequency division multiplexing
OFDM	orthogonal frequency division multiplexing
PA	power amplifier
PER	packet error rate
PHY	physical layer
PLCP	physical layer convergence protocol
PSDU	PLCP service data unit
QPSK	quadrature phase shift keying
RF	radio frequency
RX	receive or receiver
SDU	service data unit
TFC	time frequency code
TX	transmit or transmitter
UWB	ultra wideband
WPAN	wireless personal-area network

1. "Multiband OFDM Physical Layer Specification", WiMedia Alliance document, Release 1.1, July 14, 2005.

Channel Coding Components for Ultra-Wideband Design Library

UWB FCS

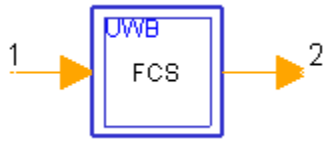

Description: UWB frame check sequence
 Library: UWB, Channel Coding
 Class: SDFUWB_FCS

Parameters

Name	Description	Default	Unit	Type	Range
DataLength	Octet number of PSDU	100		int	[1:4095]

Pin Inputs

Pin	Name	Description	Signal Type
1	PSDU	data	int

Pin Outputs

Pin	Name	Description	Signal Type
2	output	output signals	int

Notes/Equations

- This subnetwork is used to append frame check sequence after frame body.
- Frame check sequence is a 32-bit field containing a 32-bit CRC. The FCS is calculated over all the fields of the MAC header and/or the Frame Body field. These are referred to as the calculation fields.
 The FCS is calculated using the following standard generator polynomial of degree 32:

$$G(x) = x^{32} + x^{26} + x^{23} + x^{22} + x^{16} + x^{12} + x^{11} + x^{10} + x^8 + x^7 + x^5 + x^4 + x^2 + x + 1$$
 The FCS is the 1's complement of the sum (modulo 2) of the following:
 - The remainder of x^k ($x^{31} + x^{30} + x^{29} + \dots + x^2 + x + 1$) divided (modulo 2) by $G(x)$, where k is the number of bits in the calculation fields, and
 - The remainder after multiplication of the contents (treated as a polynomial) of the calculation fields by x^{32} and then division by $G(x)$.
 The FCS field is transmitted commencing with the coefficient of the highest-order term.
 As a typical implementation, at the transmitter, the initial remainder of the division is preset to all 1's and is then modified by division of the calculation fields by the generator polynomial $G(x)$. The 1's complement of this remainder is transmitted, with the highest-order bit first, as the FCS field.

3. The schematic of this subnetwork is shown in the following figure.

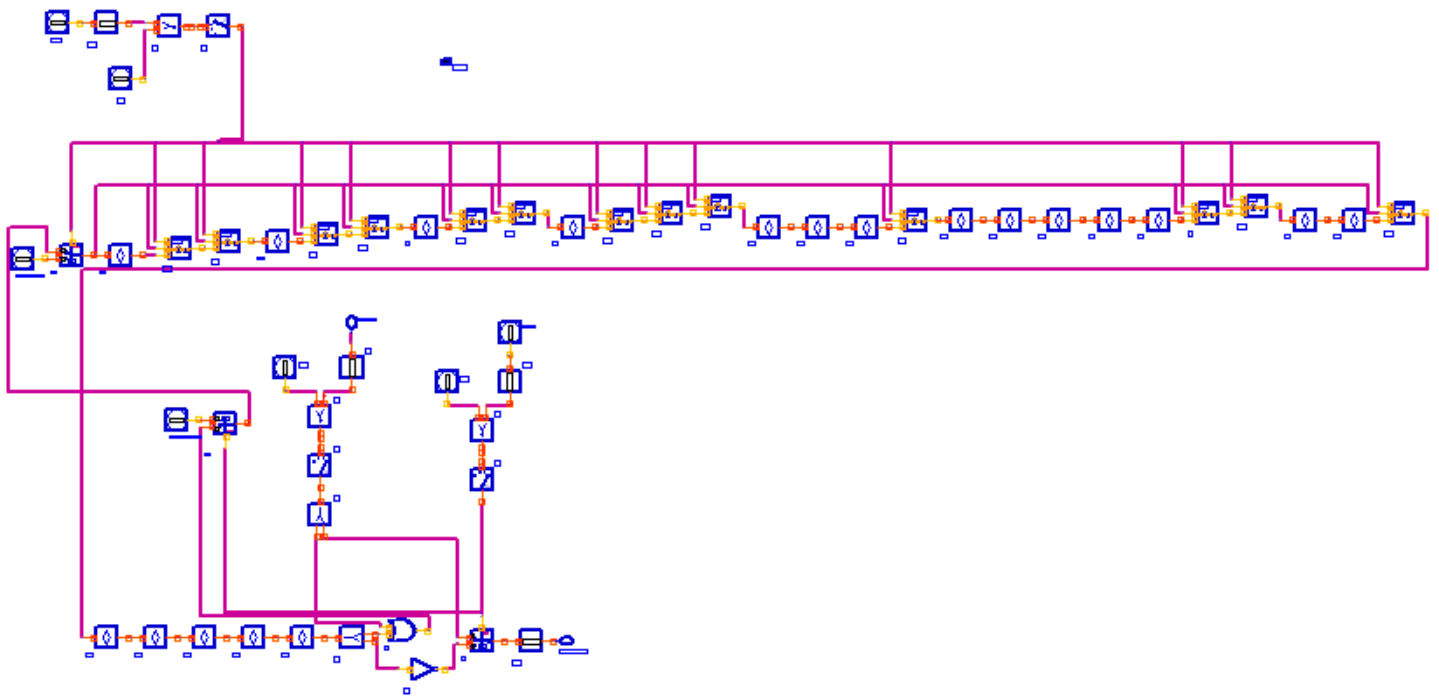

The schematic of subnetwork UWB_FCS

The CRC encoder consists of the division circuit and the control part for setting the initial value to all ones, implementing the operating of dividing, exporting the remainder and taking one's complement of the remainder. The basic unit of division circuit includes Delay and UWB_XOR. The model Delay is used to simulate the register in division circuit. The schematic of UWB_XOR is shown in the following figure. The subnetwork UWB_XOR implements logic exclusive OR operation to the its inputs from Pin 1 and Pin 2 and sends the result to component D1 if its input from Pin 3 is 1, while it will set the value of component D1 to 1, if its input from Pin 3 is 0.

1. DataLength is the length of calculation field mentioned above. The unit for DataLength is byte instead of bit. So the length of information bits shall be $8 \times \text{DataLength}$.

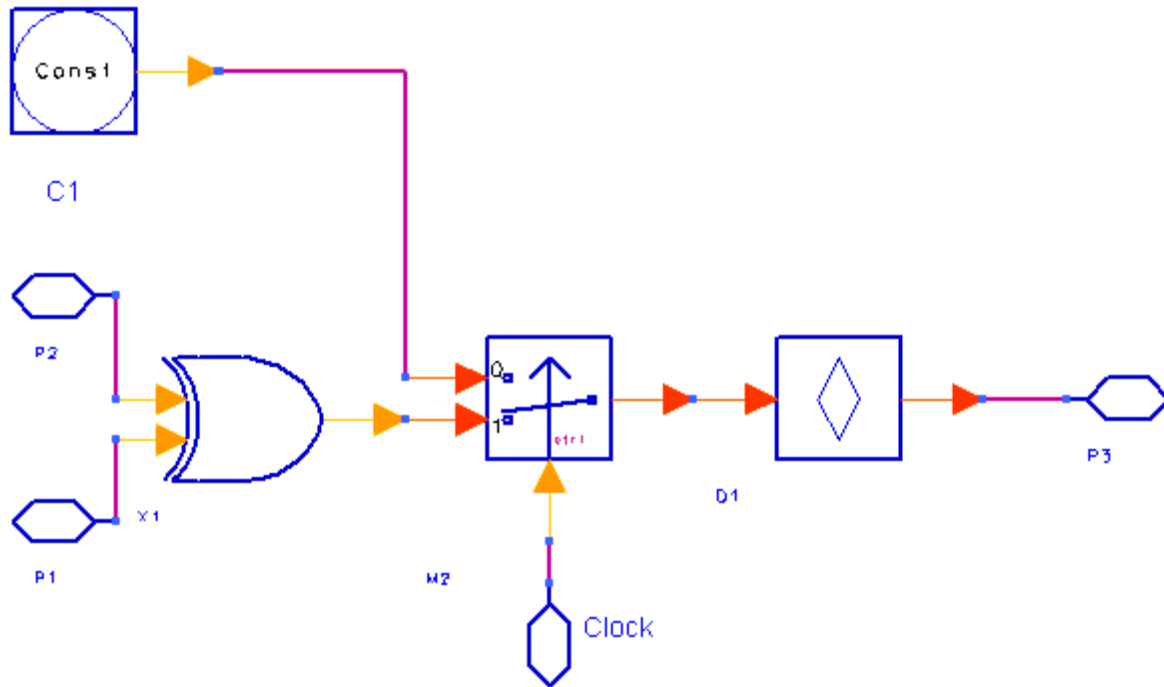

The schematic of UWB_XOR

UWB Interleaver

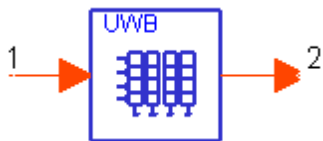

Description: UWB interleaver or de-interleaver
 Library: UWB, Channel Coding
 Class: SDFUWB_Interleaver

Parameters

Name	Description	Default	Unit	Type	Range
DataRate	Data rate: _53.3 Mbps, _55 Mbps,	_53.3 Mbps		enum	

Advanced Design System 2008

	_80 Mbps, _106.67 Mbps, _110 Mbps, _160 Mbps, _200 Mbps, _320 Mbps, _400 Mbps, _480 Mbps				
InterleavingOption	Interleaving option: Interleaving, Deinterleaving	Interleaving		enum	

Pin Inputs

Pin	Name	Description	Signal Type
1	Input	data to be processed	anytype

Pin Outputs

Pin	Name	Description	Signal Type
2	Output	processed data	anytype

Notes/Equations

- The coded and padded bit stream is interleaved prior to modulation and this model is used to perform interleaving or de-interleaving. Each firing, $6/TSF*N$ CBPS tokens are consumed and $6/TSF*N$ CBPS tokens are output. TSF is time spreading factor and N CBPS is the number of coded bits per OFDM symbol. The relationship of TSF, NCBPS and DataRate is specified in the following table.

Rate-dependent parameters

Data Rate (Mb/s)	Modulation	Coding rate (R)	Frequency-Domain Spreading (FDS)	Time-Domain Spreading (TSF)	Coded bits per OFDM symbol (NCBPS)
53.3	QPSK	1/3	Yes	Yes (2)	100
55*	QPSK	11/32	Yes	Yes (2)	100
80	QPSK	1/2	Yes	Yes (2)	100
106.7	QPSK	1/3	No	Yes (2)	200
110*	QPSK	11/32	No	Yes (2)	200

160	QPSK	1/2	No	Yes (2)	200
200	QPSK	5/8	No	Yes (2)	200
320	DCM	1/2	No	No (1)	200
400	DCM	5/8	No	No (1)	200
480	DCM	3/4	No	No (1)	200
* The data rate is not defined in the WiMedia PHY specification					

- The bit interleaving operation is performed in three stages: (i) symbol interleaving across across the OFDM symbols, followed by (ii) intra-symbol tone interleaving, and (iii) intra-symbol cyclic shifts. The symbol interleaver permutes the bits across OFDM symbols to exploit frequency across sub-bands, while the tone interleaver permutes the bits across the data tones within an OFDM symbol to exploit frequency diversity across tones and provide robustness against narrow-band interferers. This model perform all three above interleaving operations.
- Symbol block interleaver shall interleave among the $6/TSF \times N_{CBPS}$ coded bits ($6/TSF$ symbols). Let the sequences $\{U(i)\}$ and $\{S(i)\}$ represent the input and output bits of the symbol block interleaver, respectively. The input-output relationship of this interleaver shall be given by:

$$S(i) = U \left\{ \text{Floor} \left(\frac{i}{N_{CBPS}} \right) + (6/TSF) \times \text{Mod}(i, N_{CBPS}) \right\}, i=0, \dots, (6/TSF \times N_{CBPS} - 1)$$

where the function Floor(.) returns the largest integer value less than or equal to its argument value, and where Mod(.) returns the remainder after division of i by N CBPS .

- The output of the symbol block interleaver is then passed through a tone block interleaver. The outputs of the symbol block interleaver are grouped into blocks of N CBPS bits and then permuted using a regular block interleaver of size $N_{Tint} \times 10$, where $N_{Tint} = N_{CBPS} / 10$. Let the sequences $\{S(i)\}$ and $\{T(i)\}$ represent the input and output bits of the tone block interleaver, respectively. The input-output relationship of this interleaver shall be given by:

$$T(i) = S \left\{ \text{Floor} \left(\frac{i}{N_{Tint}} \right) + 10 \text{Mod}(i, N_{Tint}) \right\}, i=0, \dots, N_{CBPS} - 1$$

- The output of the tone block interleaver is then passed through the last stage, which consists of a different cyclic shift of each block of N CBPS bits within the span of the symbol block interleaver defined above. Let $\{T(b,i)\}$ and $\{V(b,i)\}$ represent the input and output sequences, respectively. The input-output relationship shall be given by:

$$V(b, i) = T(b, \text{Mod}(i + A(b), N_{CBPS})), i=0, \dots, N_{CBPS} - 1$$

For conjugate symmetric mode, $N_{CBPS} = 100$: $A(b) = b \times 33$, $b=0,1,2$

For non-conjugate symmetric mode with $TSF=2$, $N_{CBPS} = 200$: $A(b) = b \times 66$, $b=0,1,2$

For non-conjugate symmetric mode with $TSF=1$, $N_{CBPS} = 200$: $A(b) = b \times 33$, $b=0,1,2, \dots, 5$.

- When the parameter InterleavingOption is set to Interleaving, Interleaving is performed; else the reverse process is performed.

References

- "Multiband OFDM Physical Layer Specification", WiMedia Alliance document, Release 1.1, July 14, 2005.

UWB Puncturer

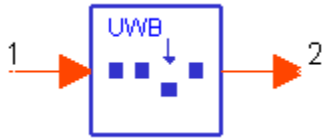

Description: UWB puncturer or de-puncturer
 Library: UWB, Channel Coding
 Class: SDFUWB_Puncturer

Parameters

Name	Description	Default	Unit	Type	Range
DataRate	Data rate: _53.3 Mbps, _55 Mbps, _80 Mbps, _106.67 Mbps, _110 Mbps, _160 Mbps, _200 Mbps, _320 Mbps, _400 Mbps, _480 Mbps	_53.3 Mbps		enum	
DataLength	Octet number of PSDU	100		int	[1:4095]
InfoType	Information type: Header, PSDU	PSDU		enum	
PunctureMode	Type of puncture mode: Stealing, Inserting: Stealing, Inserting	Stealing		enum	

Pin Inputs

Pin	Name	Description	Signal Type
1	Input	data stream to be punctured or inserted	anytype

Pin Outputs

Pin	Name	Description	Signal Type
2	Output	punctured or inserted data stream	anytype

Notes/Equations

1. This model is used to omit some of the encoded bits on the transmitter side in order to derive various coding rates from R=1/3 convolutional code, or insert a dummy "zero" bits into the convolutional decoder on the receiver side in place of the omitted bits. The multirate information will be provided in item 6.
2. If the parameter PunctureMode is set to Stealing, omitting is performed; else if the parameter PunctureMode is set to Inserting, inserting is performed.
3. If the parameter InfoType is set to Header, this model is used to process the PLCP header; else if the parameter InfoType is set to PSDU, this model is used to process the PLCP frame body.
4. The value of parameter DataLength is needed only when the parameter InfoType is set to PSDU.
5. The puncture patterns are illustrated in the four figures below. In each of these cases, the tables should be filled in with encoder output bits from the left to the right. For the last block of bits, the process should be stopped at the point at which the encoder output bits are exhausted, and the puncturing patterns applied to the partially filled block.
6. Each firing, if PunctureMode is set to Stealing, N1 tokens are consumed and N2 tokens are output; else if PunctureMode is set to Inserting, N2 tokens are consumed and N1 tokens are output, where N1 and N2 are given as follows:

$$\sqrt{1} = \lceil N_{sym} \times N_{CBPS} \times R \rceil \times$$

$$\sqrt{2} = N_{sym} \times N_{CBPS}$$

where R is coding rate, NCBPS is the number of coded bits per OFDM symbol, and Nsym is the number of OFDM symbols of PLCP header or PLCP frame body before time-domain spreading. If the parameter InfoType is set to Header, Nsym is 6; else if the parameter InfoType is set to PSDU, Nsym is calculated as follows:

$$N_{sym} = \frac{6}{TSF} \times \left\lceil \frac{\frac{8 \times DataLength + 32 + 6}{R}}{\frac{6}{TSF} \times N_{CBPS}} \right\rceil$$

where TSF is Time Spreading Factor, DataLength is the length in byte of data of PLCP frame body and is given by the parameter DataLength. The relationship of TSF, R, NCBPS and DataRate is specified in the following table.

Data Rate (Mb/s)	Modulation	Coding rate	Conjugate	Time	Overall	Coded bits per OFDM symbol (N CBPS)
53.3	QPSK	1/3	Yes	2	4	100
80	QPSK	1/2	Yes	2	4	100
110	QPSK	11/32	No	2	2	200
160	QPSK	1/2	No	2	2	200
200	QPSK	5/8	No	2	2	200
320	DCM	1/2	No	1 (No spreading)	1	200
400	DCM	5/8	No	1 (No spreading)	1	200

480	DCM	3/4	No	1 (No spreading)	1	200
-----	-----	-----	----	------------------	---	-----

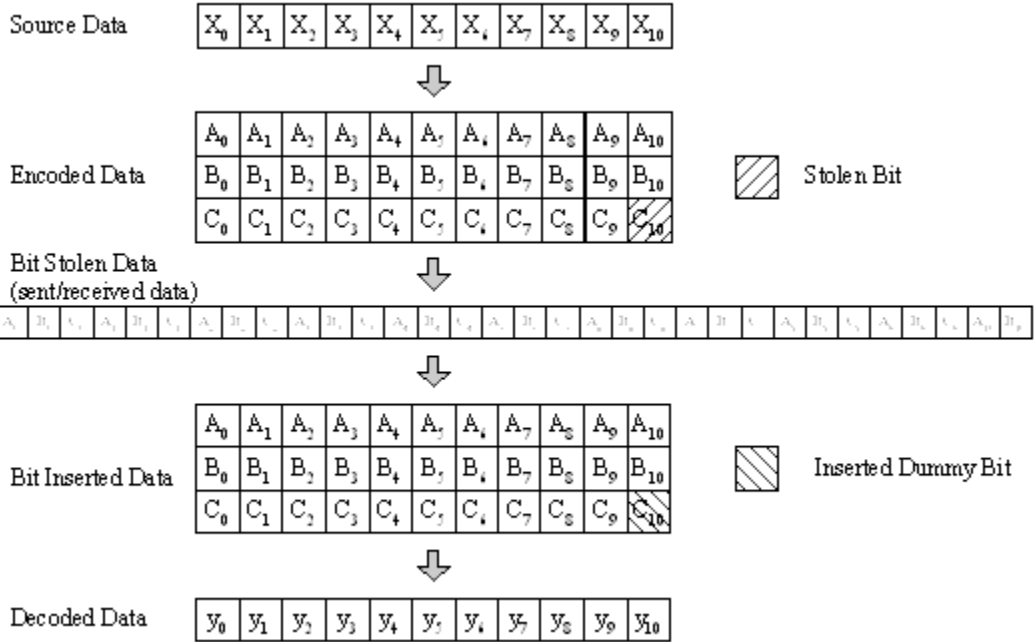

An example of the bit-stealing and bit-inserting procedure (R=11/32)

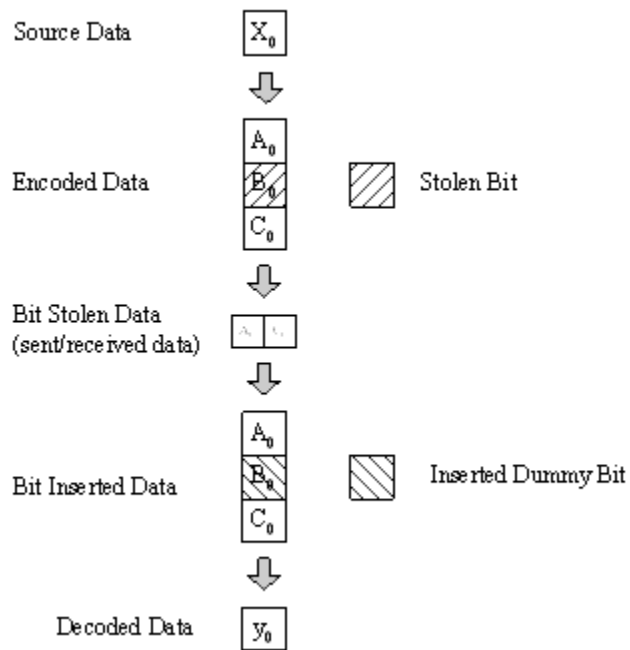

An example of the bit-stealing and bit-inserting procedure ($R=1/2$)

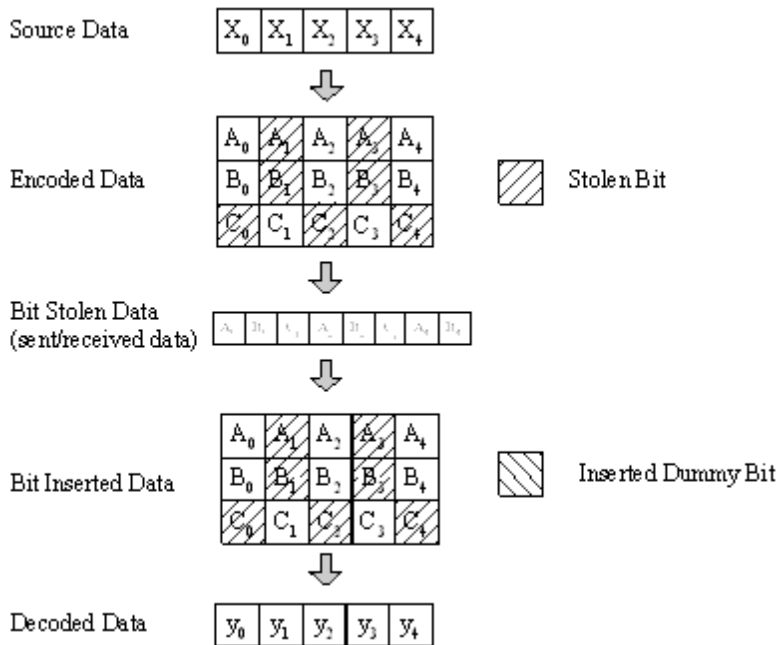

An example of the bit-stealing and bit-inserting procedure (R=5/8)

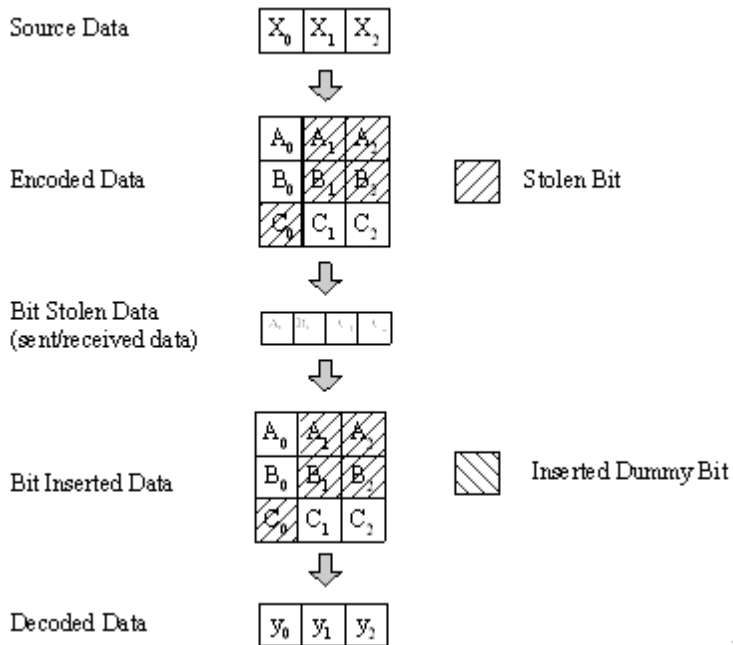

An example of the bit-stealing and bit-inserting procedure (R=3/4)

References

1. "Multiband OFDM Physical Layer Specification", WiMedia Alliance document, Release 1.1, July 14, 2005.

UWB Scrambler

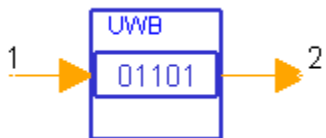

Description: UWB scrambler
 Library: UWB, Channel Coding
 Class: SDFUWB_Scrambler

Parameters

Name	Description	Default	Unit	Type	Range
DataRate	Data rate: _53.3 Mbps, _55 Mbps, _80 Mbps, _106.67 Mbps, _110 Mbps, _160 Mbps, _200 Mbps, _320 Mbps, _400 Mbps, _480 Mbps	_53.3 Mbps		enum	
DataLength	Octet number of PSDU	100		int	[1:4095]
InfoType	Information type: Header, PSDU	PSDU		enum	
ScramblerSeed	Scrambler seed selection: Seed 00, Seed 01, Seed 10, Seed 11	Seed 00		enum	

Pin Inputs

Pin	Name	Description	Signal Type
1	Input	bits to be scrambled	int

Pin Outputs

Pin	Name	Description	Signal Type
2	Output	scrambled bits	int

Notes/Equations

1. This model is used to scramble the PLCP header or the PLCP frame body. As shown in the figure below, if the parameter InfoType is set to Header, this model is used to scramble the PLCP header. Each firing, 200 tokens are consumed and 200 tokens are output. That is, the contents of the entire PLCP header are consumed, but only the combination of the MAC Header, HCS, the tail bits following it and the pad bits shall be scrambled, and the tail bits following HCS shall be reset to zero after scrambling; if the parameter InfoType is set to PSDU, this model is used to scramble the PLCP frame body. Each firing, N tokens are consumed and N tokens are output, where N is specified in the following equations. That is, the contents of the entire PLCP frame body are consumed, and all bits are scrambled, but the tail bits following FCS shall be reset to zero after scrambling.

$$N = \lceil N_{sym_{PSDU}} \times N_{CBPS} \times R \rceil$$

where R is the coding rate of PSDU, NCBPS is the number of coded bits per OFDM symbol, and NsymPSDU is the number of OFDM symbols of PSDU before time-domain spreading.

$$N_{sym_{PSDU}} = \frac{6}{TSF} \times \left\lceil \frac{\frac{8 \times DataLength + 32 + 6}{R}}{\frac{6}{TSF} \times N_{CBPS}} \right\rceil$$

where TSF is Time Spreading Factor, and DataLength is the length in byte of data of PLCP frame body and is given by the parameter DataLength. The relationship of TSF, R, NCBPS and DataRate is specified in the following table.

Data Rate (Mb/s)	Modulation	Coding rate	Conjugate	Time	Overall	Coded bits per OFDM symbol (N CBPS)
53.3	QPSK	1/3	Yes	2	4	100
80	QPSK	1/2	Yes	2	4	100
110	QPSK	11/32	No	2	2	200
160	QPSK	1/2	No	2	2	200
200	QPSK	5/8	No	2	2	200
320	DCM	1/2	No	1 (No spreading)	1	200
400	DCM	5/8	No	1 (No spreading)	1	200
480	DCM	3/4	No	1 (No spreading)	1	200

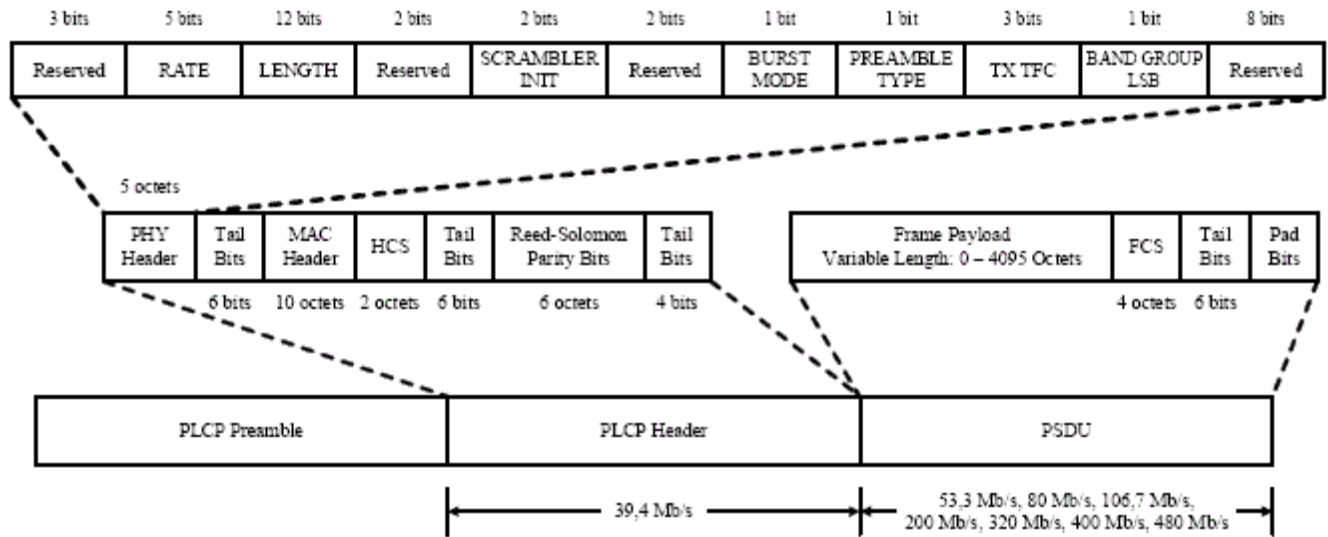

PLCP frame format

- The polynomial generator, $g(D)$, for pseudo-random binary sequence (PRBS) used to scramble the input bits shall be $g(D) = 1 + D^{14} + D^{15}$, where D is a single bit delay. The polynomial not only forms a maximal length sequence, but is also a primitive polynomial. Using this generator, the corresponding PRBS, x_n is generated as $x_n = x_{n-14} \oplus x_{n-15}$, $n=0,1,2,\dots$

The following sequence defines the initialization vector, x_{init} , which is specified by the parameter seed value in the following table.

$$x_{init} = [x_{n-1}^i x_{n-1}^i \dots x_{n-14}^i x_{n-15}^i]$$

where x_{n-k}^i represents the binary initial value at the output of the k th delay element.

Seed identifier (S 1 ,S 2)	Seed value (x -1 x -2 ...x -14 x -15)	Scrambler Output First 16 bits
0,0	0011 1111 1111 111	0000000000001000
0,1	0111 1111 1111 111	0000000000000100
1,0	1011 1111 1111 111	0000000000001110
1,1	1111 1111 1111 111	0000000000000010

Scrambler seed selection

- At the first firing, the seed identifier used to initialize the PRBS is specified by the parameter ScramblerSeed. At the subsequent firings, the PRBS is initialized with seed identifier increased in a 2-bit rollover counter for each PLCP header or PLCP frame body.
- The output scrambled data bits, s_m , are obtained as follows: $s_m = d_m \oplus x_m$, $m=0,1,2,\dots$

where d_m represents the unscrambled data bits.

References

1. "Multiband OFDM Physical Layer Specification", WiMedia Alliance document, Release 1.1, July 14, 2005.

Measurement Components for Ultra-Wideband Design Library

UWB MBOFDM EVM



Description: UWB MBOFDM EVM measurement for FreqHopping and Non-FreqHopping signals

Library: UWB, Measurement

Class: TSDF_UWB_MBOFDM_EVM

Parameters

Name	Description	Default	Unit	Type	Range
RLoad	load resistance. DefaultRLoad will inherit from the DF controller.	DefaultRLoad	Ohm	real	(0, ∞)
RTemp	physical temperature, in degrees C, of load resistance. DefaultRTemp will inherit from the DF controller.	DefaultRTemp	Celsius	real	[-273.15, ∞)
FCarrier	carrier frequency (-1 means same as input)	3960 MHz	Hz	real	(0, ∞)
MirrorSpectrum	Mirror frequency	NO		enum	

Advanced Design System 2008

	spectrum?: NO, YES				
Start	start time for data recording. DefaultTimeStart will inherit from the DF Controller.	DefaultTimeStart	sec	real	[0, ∞)
AverageType	average type: Off, RMS (Video)	RMS (Video)		enum	
FramesToAverage	number of frames that will be averaged if AverageType is RMS (Video)	10		int	[1, ∞)
SearchLength	search length, it's better to include more than 2 full frames	500 usec	sec	real	(0, ∞)
ResultLength	result length when ResultLengthType is set to Manual Override. If ResultLengthType is set to Auto Select then this value is used as the maximum ResultLength.	60		int	[0:999]
MeasurementOffset	measurement offset (the first MeasurementOffset number of data symbols shall be excluded for EVM)	0		int	[0:999]
MeasurementInterval	number of data symbols to be measured	48		int	[1:1000]
TFC	TFC number: TFC 1, TFC 2, TFC 3, TFC 4, TFC 5, TFC 6, TFC 7	TFC 1		enum	
PreambleType	stand preamble	Standard		enum	

Advanced Design System 2008

	or short preamble: Standard Preamble, short Preamble	Preamble			
DataRate	information transmit rate of data part: _53.3 Mbps, _80 Mbps, _106.7 Mbps, _160 Mbps, _200 Mbps, _320 Mbps, _400 Mbps, _480 Mbps	_53.3 Mbps		enum	
FreqHopping	frequency hopping analysis or not, only valid for TFC 1 2 3 and 4: NO, YES	YES		enum	
TrkPhaseAvgSym	symbol numbers to average of non-preamble part in phase tracking, EveryFrame means no average: FollowSpec, EveryFrame	FollowSpec		enum	
PmbIPhaseAvgSym	symbol numbers to average of preamble part in phase error calculating	5		int	[0, 12]
SymbolTimingAdjust	symbol time adjustment in "Bandwidth" sample rate before the valid symbol portion	-1		real	[-10, 0]
Bandwidth	real bandwidth of input signal in each band	528 MHz		real	(0, inf)
SaveConstellation	if set YES, the measured vector	NO		enum	(0, inf)

	used for EVM calculation shall be saved to Data File: NO, YES				
--	---	--	--	--	--

Pin Inputs

Pin	Name	Description	Signal Type
1	input	input signal	timed

Notes/Equations

1. This model is used to perform EVM (Error Vector Magnitude or Relative Constellation Error) measurement for UWB MB-OFDM signal. Format of the input signal should be compatible with the WiMedia PHY specification (see [Reference 1](#)). Signals with and without frequency-hopping are both supported.
2. The input signal should be a timed RF (complex envelope) signal or this model will error out. This measurement provides results in Data Display for:

RCE_dB (Relative Constellation Error in dB of all non-zero sub-carriers of analyzed OFDM symbols, if frequency-hopping exists, the RCE in each sub-band shall be displayed in the Simulation/Synthesis Message box),

RCE_rms_percent (Relative Constellation Error in root mean square percentage of all non-zero sub-carriers of analyzed OFDM symbols),

Constellation (the equalized vector being measured in all detected frames, constellation may be displayed in Data Display System with this vector).

Additionally, synchronization correlation coefficient, carrier frequency offset as well as some other auxiliary information are provided in Simulation/Synthesis Messages box.

3. The algorithm used here is the same as the one used in Agilent 89600 software. Following is a brief description of the algorithm.
Starting at the time instant specified by the Start parameter, a signal segment of length SearchLength is acquired. This signal segment is searched in order for a complete burst (or frame) to be detected.

The burst search algorithm looks for both a burst on and a burst off transition. In order for the burst search algorithm to detect a burst, an idle part must exist between consecutive bursts and the bursts should be at least 15 dB above the noise floor.

Advanced Design System 2008

If the acquired signal segment does not contain a complete burst, the algorithm will not detect any burst and the analysis that follows will most likely produce incorrect results. Therefore, SearchLength must be long enough to acquire at least one complete burst. Because the time instant specified by the Start parameter can be soon after the beginning of a burst, it is recommended that SearchLength be set to a value equal to or greater than $2 * \text{burstLength} + 3 * \text{idle}$, where burstLength is the duration of a burst in seconds. If duration of the burst or the idle part is unknown, then a TimedSink component can be used to record the signal and the signal can be plotted in the Data Display. By observing the magnitude of the signal's envelope versus time one can determine the duration of the burst and the idle interval.

After a burst is detected, synchronization is performed. The burst is then demodulated (the FCarrier parameter sets the frequency of the internal local oscillator signal) and analyzed to get the EVM measurement results.

If AverageType is set to Off, only one burst is detected, demodulated, and analyzed.

If AverageType is set to RMS (Video), after the first burst is analyzed the signal segment corresponding to it is discarded and new signal samples are collected from the input to fill in the signal buffer of length SearchLength. When the buffer is full again a new burst search is performed and when a burst is detected it is demodulated and analyzed. These steps repeat until FramesToAverage bursts are processed or SearchLength*FramesToAverage long signals are analyzed.

If for any reason a burst is misdetectd (in this model, if synchronization correlation coefficient is less than 0.6, the burst shall be discarded) the results from its analysis are discarded. The EVM results obtained from all the successfully detected, demodulated, and analyzed bursts are averaged to give the average result.

4. Parameter details.

FCarrier is the internal local oscillator frequency used by demodulator. If set -1, local carrier frequency inside the model shall be the same as that of the input signal.

MirrorSpectrum is used to mirror the spectrum (invert the Q envelope) of input signal.

Start indicates the time instant from which the input signal is collected for measurement.

AverageType is used to select average type of measurement. If it is set to Off, only one burst is detected, demodulated, and analyzed. If it is set to RMS (Video), measurement shall be repeated until FramesToAverage bursts are detected or SearchLength*FramesToAverage long signals are analyzed.

SearchLength indicates how long a signal is used in each measurement. It's recommended that SearchLength be set a value of a little more than 2 times of the duration of a valid burst plus idle part.

ResultLength indicates the maximum number of OFDM symbols that may be used for measurement in a burst. The preamble symbols are not included in ResultLength (only PLCP header and PSDU are taken into account).

MeasurementOffset indicates the number of OFDM symbols at the beginning of PLCP header and PSDU that shall be discarded in EVM calculation. It should be less than ResultLength. For EVM of PLCP header and PSDU, MeasurementOffset should be to 0. For EVM of PSDU, MeasurementOffset should be set 12.

MeasurementInterval indicates the number of data OFDM symbols used for EVM calculation. It should be less than the real number of OFDM symbols contained in PLCP header and PSDU, and should be less than ResultLength. The sum of MeasurementOffset and MeasurementInterval should be less than ResultLength. Otherwise, the measurement result shall be unreliable. See the following figure for the relationship of SearchLength, MeasurementOffset, and MeasurementInterval.

Relationship of SearchLength, MeasurementOffset and MeasurementInterval

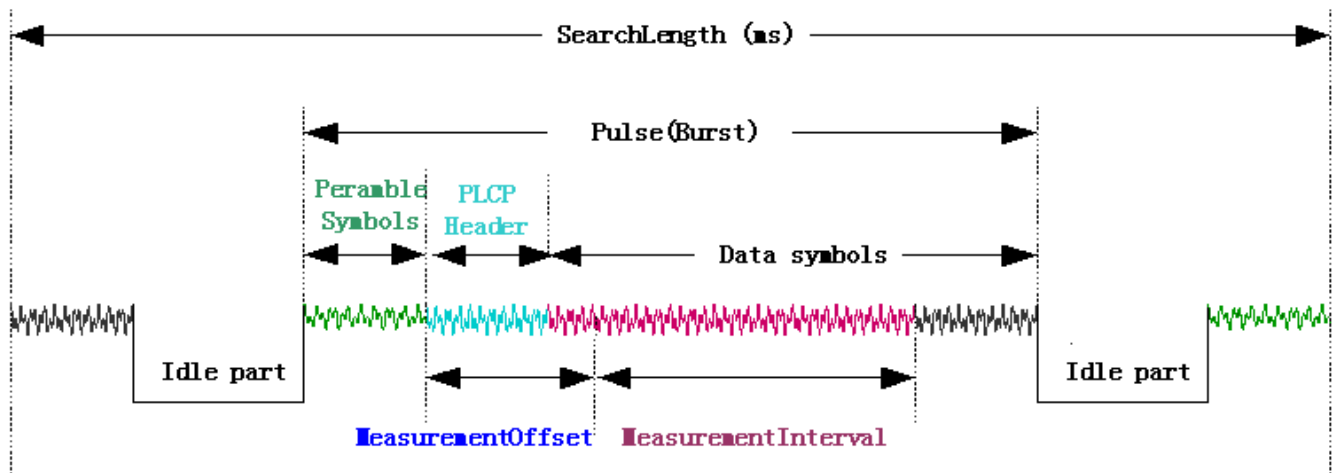

FrequencyHopping tells the model that the input signal is a frequency hopping signal or not. If NO is set, TFC shall be used to determine the preamble sequence rather than both preamble sequence and frequency hopping pattern. If, by default, YES is set, the input signal should be with a sample rate of at least $4 \times \text{Bandwidth}$.

SymbolTimingAdjust is used for optimal demodulation. This parameter controls how far the FFT window is back away from the estimated one. The value is in terms of samples at the sample rate of parameter Bandwidth. Note that this parameter value is negative, because the FFT start time is moved back by this parameter. For EVM measurement, -1 is recommended.

Bandwidth is the real bandwidth of the input signal, the default value is 528 MHz.

SaveConstellation is an option for one to save the equalized vector being measured to the data file. If YES is selected, measured vector in all successfully analyzed bursts are saved to the data file and one may plot constellation of the measured signal in the Data Display System.

References

[1] "Multiband OFDM Physical Layer Specification", WiMedia Alliance document, Release 1.1, July 14, 2005.

UWB RF CCDF

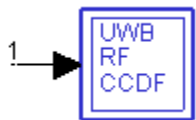

Description: UWB CCDF measurement
 Library: UWB, Measurement
 Class: TSDFUWB_RF_CCDF

Parameters

Name	Description	Default	Unit	Type	Range
RLoad	Input resistance	DefaultRLoad	Ohm	real	(0, ∞)
RTemp	Temperature	DefaultRTemp	Celsius	real	[-273.15, ∞)
StartSym	Symbol from which measurement begin	25740		int	[0, ∞)
BurstLen	length of input	6600		int	[1, inf)

Advanced Design System 2008

	signal burst				
BurstNum	Number of bursts	78		int	[1,inf)
OutputPoint	Indicate output precision	100		int	[1,inf)
DataRate	Data rate: _53.3 Mbps, _55 Mbps, _80 Mbps, _106.67 Mbps, _110 Mbps, _160 Mbps, _200 Mbps, _320 Mbps, _400 Mbps, _480 Mbps	_53.3 Mbps		enum	
DataLength	Octet number of PSDU	100		int	[1:4095]
PreambleFormat	PLCP preamble format: Standard Format, Burst Format	Standard Format		enum	
TFC_Number	Time frequency code: TFC1, TFC2, TFC3, TFC4, TFC5, TFC6, TFC7	TFC1		enum	
OversamplingOption	Oversampling ratio: Ratio 1, Ratio 2, Ratio 4, Ratio 8, Ratio 16, Ratio 32	Ratio 2		enum	
Bandwidth	Bandwidth	528 MHz	Hz	real	(0, ∞)
CyclicPrefix	Cyclic prefix with zero padding	70.08 nsec	sec	real	[0, ∞)
GuardInterval	Guard interval with zero padding	0.0 nsec	sec	real	[0, ∞)
IdleInterval	Idle Interval	0.0 nsec	sec	real	[0, ∞)

Pin Inputs

Pin	Name	Description	Signal Type
1	RF_Signal	received RF signal to be measured	timed

Notes/Equations

1. This subnetwork is used to measure complementary cumulative distribution function (CCDF) of the RF signal.
2. The schematic of this subnetwork is shown in the following figure. The UWB_FrameSync performs frame synchronization and the parameters from DataRate to IdleInterval are used to configure it, and the settings of these parameters should be consistent with that of the UWB signal source. UWB_DemuxFrame extracts the synchronized frames, which are output to UWB_DisFunc for CCDF measurement. The measurement result are collected by four NumericSink. The distribution range is sent to the NumericSink identified by SignalRange_dB and is divided into segments according to the parameter OutputPoint. The corresponding distribution probability is calculated based on these segments and sent to the NumericSink identified by CCDF. UWB_DisFunc calculates peak power of 99.9% probability and average power of the input signals. These results are collected by the NumericSinks identified as PeakPower and MeanPower. Note that PeakPower, MeanPower and SignalRange units are dBm; SignalRange is the absolute signal power minus MeanPower.

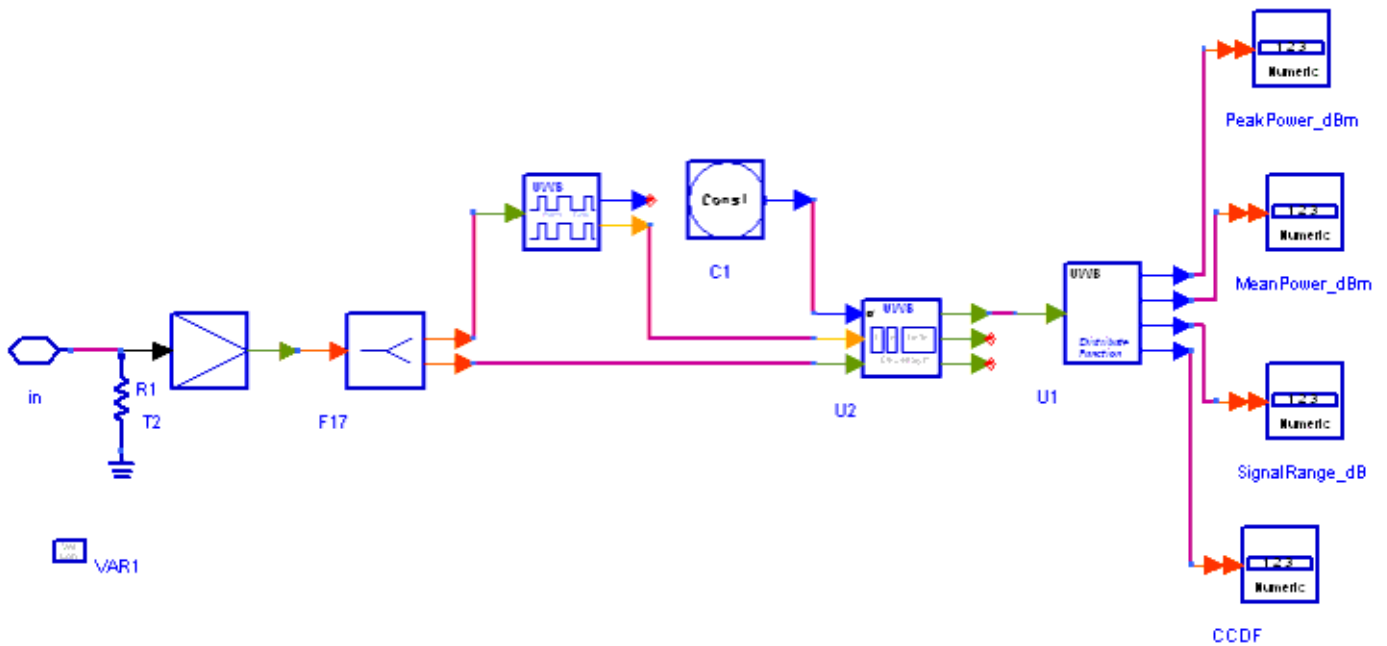

UWB_RF_CCDF schematic

References

1. "Multiband OFDM Physical Layer Specification", WiMedia Alliance document, Release 1.1, July 14, 2005.

Multiplex Components for Ultra-Wideband Design Library

UWB DemuxDataPLCP

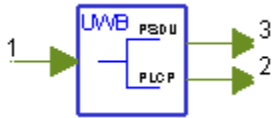

Description: UWB PLCP header and PSDU demultiplexer

Library: UWB, Multiplex

Class: SDFUWB_DemuxDataPLCP

Parameters

Name	Description	Default	Unit	Type	Range
DataRate	Data rate: _53.3 Mbps, _55 Mbps, _80 Mbps, _106.67 Mbps, _110 Mbps, _160 Mbps, _200 Mbps, _320 Mbps, _400 Mbps, _480 Mbps	_53.3 Mbps		enum	
DataLength	Octet number of PSDU	100		int	[1:4095]

Pin Inputs

Pin	Name	Description	Signal Type
1	Input	data to be demultiplexed	complex

Pin Outputs

Pin	Name	Description	Signal Type
2	PLCPHeader	PLCP header	complex
3	PSDU	PSDU	complex

Notes/Equations

1. This model is used to de-multiplex PLCP header and PSDU in an OFDM frame. Each firing, $122 \cdot N_{sym_despreading}$ tokens are consumed, where $N_{sym_despreading}$ is the number of OFDM symbols in PLCP header and PSDU after despreading; $122 \cdot N_{sym}$ Header-despreading tokens are output at pin PLCPHeader and $122 \cdot N_{sym}$ PSDU-despreading tokens are output at pin PSDU, where N_{sym} Header-despreading is the number of OFDM symbols in PLCP header after time domain despreading, and N_{sym} PSDU-despreading is the number of OFDM symbols in PSDU after time domain despreading.
2. The number of de-multiplexed OFDM symbols are calculated as follows:

$$N_{sym_{Header-despreading}} = 6$$

$$N_{sym_{PSDU-despreading}} = \frac{6}{TFC} \times \left\lceil \frac{8 \times DataLength + 38}{N_{IBP6S}} \right\rceil$$

Where N_{IBP6S} is the information bits per 6 OFDM symbols, TSF is Time Spreading Factor, which is 2 for Time-Domain Spreading and 1 otherwise. They are determined by the data rate. Please refer to the following table for detail.

rate-dependent parameters

Data Rate (Mb/s)	Modulation	Coding rate (R)	Frequency-Domain Spreading (FDS)	Time-Domain Spreading (TDS)	Coded bits / 6 OFDM symbol (NCBP6S)	Info bits / 6 OFDM symbol (NIBP6S)
53.3	QPSK	1/3	Yes	Yes	300	100
55*	QPSK	11/32	Yes	Yes	300	103.125
80	QPSK	1/2	Yes	Yes	300	150
106.7	QPSK	1/3	No	Yes	600	200
110*	QPSK	11/32	No	Yes	600	206.25
160	QPSK	1/2	No	Yes	600	300
200	QPSK	5/8	No	Yes	600	375
320	DCM	1/2	No	No	1200	600
400	DCM	5/8	No	No	1200	750
480	DCM	3/4	No	No	1200	900

Notes: * denotes the data rate which the new specification is not defined

References

1. "Multiband OFDM Physical Layer Specification", WiMedia Alliance document, Release 1.1, July 14, 2005.

UWB DemuxOFDMSym



Description: UWB OFDM symbol demultiplexer

Library: UWB, Multiplex

Class: SDFUWB_DemuxOFDMSym

Pin Inputs

Pin	Name	Description	Signal Type
1	In	data subcarriers input	complex

Pin Outputs

Pin	Name	Description	Signal Type
2	Data	OFDM symbol output	complex

Notes/Equations

1. This model is used to extract the data from their corresponding subcarriers. Only the data are sent to the output, while the pilot and guard are discarded.
Each firing 100 Data tokens are produced when 122 In tokens consumed.
2. In transmitter end, the input data are mapped from the indices 0 to 99 to the logical frequency offset indices -56 to 56, excluding the locations reserved for the pilot subcarriers, guard subcarriers, and the DC subcarrier. Please refer to online manual for UWB_MuxOFDMSym for detail.
This model implements the reverse operation and extract the data from the data subcarriers.

References

1. "Multiband OFDM Physical Layer Specification", WiMedia Alliance document, Release 1.1, July 14, 2005.

UWB GuardGain



Description: UWB guard subcarriers gain

Library: UWB, Multiplex

Class: SDFUWB_GuardGain

Parameters

Name	Description	Default	Unit	Type	Range
GuardGain	Gain of guard subcarriers	1.0, 1.0, 1.0, 1.0, 1.0		real array	(0, ∞)

Pin Inputs

Pin	Name	Description	Signal Type
1	Input	data subcarriers input	complex

Pin Outputs

Pin	Name	Description	Signal Type
2	Output	OFDM symbol output	complex

Notes/Equations

1. This subnetwork is used to adjust the gain of guard subcarriers. The schematic of this subnetwork is shown in the following figure.

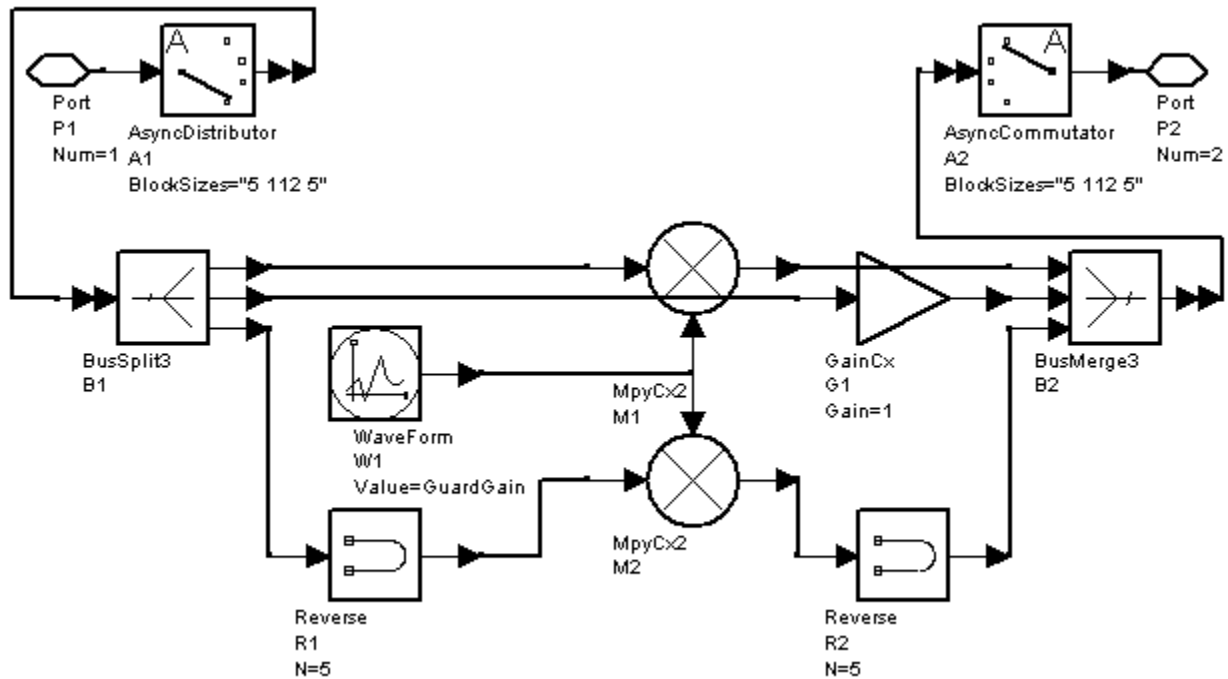

The schematic of subnetwork UWB_GuardGain

This function is not defined in IEEE specifications. But to change the gain of guard subcarriers is required in some case. With this subnetwork, the amplitude of guard subcarriers can be customized by setting the parameter GuardGain.

GuardGain is a floating-point array. The number of element of this array should be 5 unless it is intended to be other values. If the number of element is less than 5, zeros will be append to make them 5 element. If the number of element is larger than 5, the sixth and the follows will be the guard gain of the second OFDM symbol. This parameter only specifies 5 gain values of positive guard subcarriers. The gain for negative guard subcarriers will be set automatically according to the rule of mirror.

References

1. IEEE P802.15-04/0493r1, Multi-band OFDM Physical Layer Proposal for IEEE 802.15 Task Group 3a, September 2004.
2. IEEE P802.15-03/0268r3, Multi-band OFDM Physical Layer Proposal for IEEE 802.15 Task Group 3a, May 2004.

UWB MuxFrame

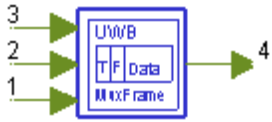

Description: UWB frame multiplexer

Library: UWB, Multiplex

Class: SDFUWB_MuxFrame

Parameters

Name	Description	Default	Unit	Type	Range
DataRate	Data rate: _53.3 Mbps, _55 Mbps, _80 Mbps, _106.67 Mbps, _110 Mbps, _160 Mbps, _200 Mbps, _320 Mbps, _400 Mbps, _480 Mbps	_53.3 Mbps		enum	
DataLength	Octet number of PSDU	100		int	[1:4095]
PreambleFormat	PLCP preamble format: Standard Format, Burst Format	Standard Format		enum	
OversamplingOption	Oversampling ratio: Ratio 1, Ratio 2, Ratio 4, Ratio 8, Ratio 16, Ratio 32	Ratio 2		enum	
Bandwidth	Bandwidth	528 MHz	Hz	real	(0, ∞)
CyclicPrefix	Cyclic prefix with zero padding	70.08 nsec	sec	real	[0, ∞)
GuardInterval	Guard interval with zero padding	0.0 nsec	sec	real	[0, ∞)
IdleInterval	Idle Interval	0.0 nsec	sec	real	[0, ∞)

Pin Inputs

Pin	Name	Description	Signal Type
-----	------	-------------	-------------

1	Preamble	preamble	complex
2	Hdr_Data	header and data	complex

Pin Outputs

Pin	Name	Description	Signal Type
3	Out	data after mutiplexing	complex

Notes/Equations

- This subnetwork is used to multiplex the PLCP preamble (OFDM) symbols and the concatenation of PLCP Header and PSDU (OFDM) symbols into one frame.

Input of the Preamble pin is time domain waveform of the preamble part without zero padding, which includes the frame synchronization sequence and channel estimation sequence.

Input of the Hdr_Data pin is time domain waveform of the concatenation of PLCP Header and PSDU without zero padding.

Each firing,

$$128 \cdot N_{sync} \cdot 2^{OversamplingOption}$$

tokens are consumed at the Preamble pin, $128 \cdot (N_{hdr} + N_{frame}) \cdot 2^{OversamplingOption}$

tokens are consumed at the Hdr_Data pin, and

$$[S_{idle} + (128 + S_{CP} + S_{GI}) \cdot (N_{sync} + N_{hdr} + N_{frame})] \cdot 2^{OversamplingOption}$$

tokens are consumed at the Out pin,

where

$$N_{sync} = \begin{cases} 30 & StandardPreamble \\ 18 & BurstPreamble \end{cases}$$

is the number of OFDM symbols in the PLCP Preamble,

$$N_{hdr} = 12$$

is the number of OFDM symbols in the PLCP Header,

$$N_{frame} = 6 \times \left\lceil \frac{8 \times DataLength + 32 + 6}{N_{IBP6S}} \right\rceil$$

is the number of OFDM symbols in the PSDU,

$$S_{idle} = \lfloor IdleInterval \cdot Bandwidth + 0.5 \rfloor$$

is the number of samples of the idle part between consecutive bursts at the sample rate of Bandwidth,

$$S_{CP} = \lfloor CyclicPrefix \cdot Bandwidth + 0.5 \rfloor$$

is the number of samples of the zero padded part in each OFDM symbol at the sample rate of Bandwidth,

$$S_{GI} = \lfloor GuardInterval \cdot Bandwidth + 0.5 \rfloor$$

is the number of samples of guard interval part in each OFDM symbol at the sample rate of Bandwidth, just

similar with S_{CP} , and should be set 0 by default.

2. The schematic of this subnetwork is shown in the following figure:

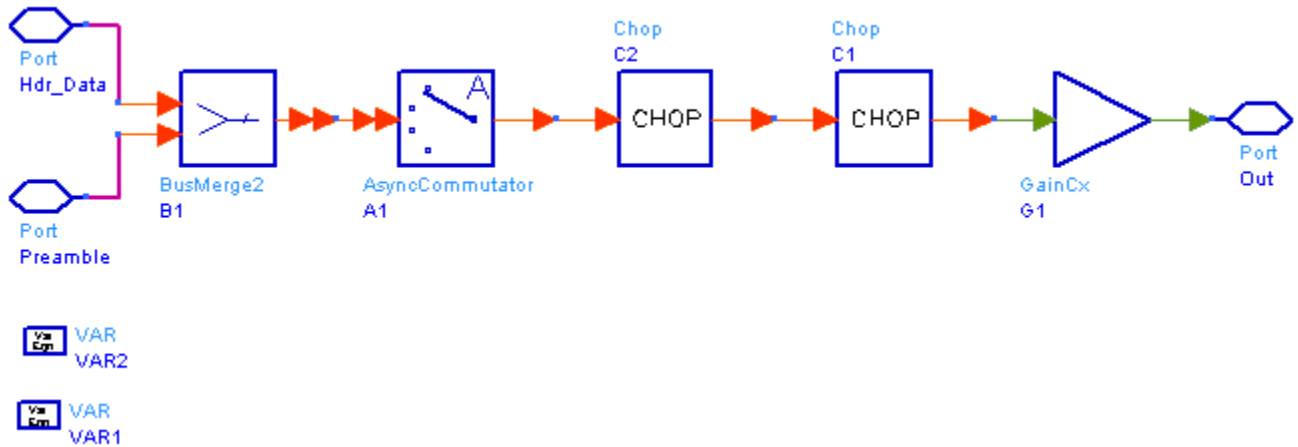

The schematic of subnetwork UWB_MuxFrame

Firstly, the Hdr_Data signals are padded to Preamble signals. Then, each OFDM symbol are zero padded. Next, an idle signal is put ahead of the zero padded signal. Finally, signal power is adjusted by a gain so as for the average (idle interval part is not taken into account) output power is the same as the input signals.

3. DataRate, PreambleFormat and DataLength parameters are used to determine the number of OFDM symbols per UWB MB-OFDM frame. Please refer to the following table for details.

Rate-dependent parameters

Data Rate (Mb/s)	Modulation	Coding rate (R)	Frequency-Domain Spreading (FDS)	Time-Domain Spreading (TDS)	Coded bits / 6 OFDM symbol (NCBP6S)	Info bits / 6 OFDM symbol (NIBP6S)
53.3	QPSK	1/3	Yes	Yes	300	100
55*	QPSK	11/32	Yes	Yes	300	103.125
80	QPSK	1/2	Yes	Yes	300	150
106.7	QPSK	1/3	No	Yes	600	200
110*	QPSK	11/32	No	Yes	600	206.25
160	QPSK	1/2	No	Yes	600	300
200	QPSK	5/8	No	Yes	600	375
320	DCM	1/2	No	No	1200	600
400	DCM	5/8	No	No	1200	750
480	DCM	3/4	No	No	1200	900

* the data rate is not defined in the WiMedia PHY specification

References

1. "Multiband OFDM Physical Layer Specification", WiMedia Alliance document, Release 1.1, July 14, 2005.

UWB MuxHeadPSDU

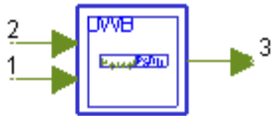

Description: UWB PLCP header and PSDU multiplexer

Library: UWB, Multiplex

Class: SDFUWB_MuxHeadPSDU

Parameters

Name	Description	Default	Unit	Type	Range
DataRate	Data rate: _53.3 Mbps, _55 Mbps, _80 Mbps, _106.67 Mbps, _110 Mbps, _160 Mbps, _200 Mbps, _320 Mbps, _400 Mbps, _480 Mbps	_53.3 Mbps		enum	
DataLength	Octet number of PSDU	100		int	[1:4095]

Pin Inputs

Pin	Name	Description	Signal Type
1	Header	PLCP header	complex
2	PSDU	data	complex

Pin Outputs

Pin	Name	Description	Signal Type
3	output	output signals	complex

Notes/Equations

1. This subnetwork is used to multiplex OFDM symbols of PLCP Header and PSDU. PLCP Header stands for physical layer convergence procedure and PSDU stands for PHY sublayer service data units. The schematic of this subnetwork is shown in the following figure.

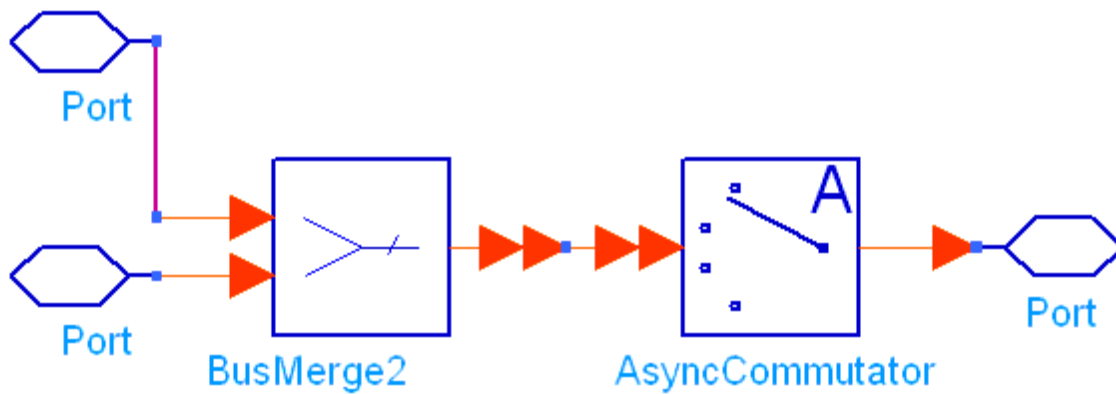

Var Eqn VAR

The schematic of UWB_MuxHeadPSDU

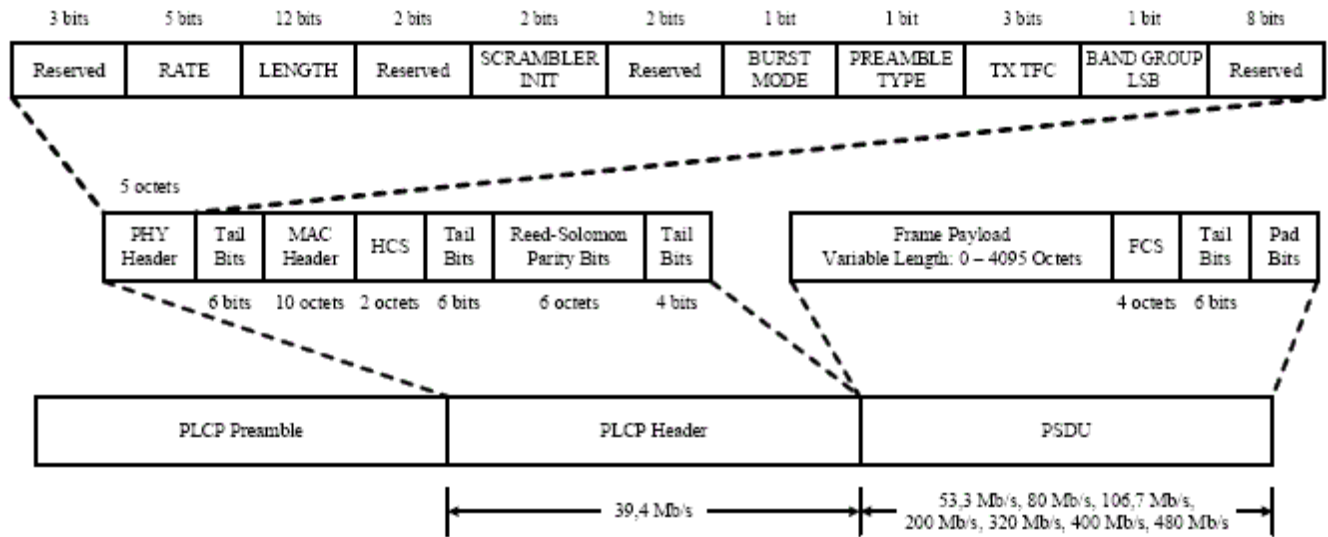

PLCP frame format

The figure above shows the frame format of UWB. The function of this subnetwork is to multiplex the latter two parts, that is, PLCP Header and PSDU. According to the figure, the data rate and data length of PLCP Header are fixed, so the number of OFDM symbols for PLCP Header is fixed to 6; The data rate and data length for PSDU is variable, and the number of OFDM symbol can be calculated using equations. The equations can be found in the [schematic of subnetwork UWB_MuxHeadPSDU](#), where N_{Sym} is the number of OFDM symbol for PSDU and ceil is a function to get the minimal integer larger or equal to its argument.

Note that time frequency codes are implemented after this model in the data flow.

2. Each OFDM symbol includes 122 subcarriers, which means a block of 122 data is transmitted for each OFDM symbol.

References

1. "Multiband OFDM Physical Layer Specification", WiMedia Alliance document, Release 1.1, July 14, 2005.

UWB MuxOFDMSym



Description: UWB OFDM symbol multiplexer
 Library: UWB, Multiplex
 Class: SDFUWB_MuxOFDMSym

Parameters

Name	Description	Default	Unit	Type	Range
DataRate	Data rate: _53.3 Mbps, _55 Mbps, _80 Mbps, _106.67 Mbps, _110 Mbps, _160 Mbps, _200 Mbps, _320 Mbps, _400 Mbps, _480 Mbps	_53.3 Mbps		enum	
DataLength	Octet number of PSDU	100		int	[1:4095]
InfoType	Information type: Header, PSDU	PSDU		enum	
PilotPN_Phase	Phase of pilot PN	0		int	[0:126]

Pin Inputs

Pin	Name	Description	Signal Type
1	Data	data subcarriers input	complex

Pin Outputs

Pin	Name	Description	Signal Type
2	Out	OFDM symbol output	complex

Notes/Equations

1. This model is used to map the data, pilot and guard into their corresponding subcarriers. The data are from the input, while the pilot and guard are generated by this model.
 Each firing 122 Out tokens are produced when 100 Data tokens consumed.
2. Firstly, the input data will be mapped from the indices 0 to 99 to the logical frequency offset indices -56 to 56,

excluding the locations reserved for the pilot subcarriers, guard subcarriers, and the DC subcarrier, as shown below:

$$M(n) = \begin{cases} n - 56 & n = 0 \\ n - 55 & 1 \leq n \leq 9 \\ n - 54 & 10 \leq n \leq 18 \\ n - 53 & 19 \leq n \leq 27 \\ n - 52 & 28 \leq n \leq 36 \\ n - 51 & 37 \leq n \leq 45 \\ n - 50 & 46 \leq n \leq 49 \\ n - 49 & 50 \leq n \leq 53 \\ n - 48 & 54 \leq n \leq 62 \\ n - 47 & 63 \leq n \leq 71 \\ n - 46 & 72 \leq n \leq 80 \\ n - 45 & 81 \leq n \leq 89 \\ n - 44 & 90 \leq n \leq 98 \\ n - 43 & n = 99 \end{cases}$$

The schematic of subnetwork UWB_GuardGain

Twelve of the subcarriers for pilot signals are generated according to the chapter 1.13.1 in [1]. They are put in subcarriers numbered -55, -45, -35, -25, -15, -5, 5, 15, 25, 35, 45, and 55. The value of pilot may be different according to the setting of parameter DataRate and InfoType.

10 guard subcarriers are generated according to the chapter 1.13.2 in [1]. They are located in subcarriers with indices -61, -60,..., -57, and 57, 58,..., 61.

References

1. IEEE P802.15-04/0493r1, Multi-band OFDM Physical Layer Proposal for IEEE 802.15 Task Group 3a, September 2004.
2. IEEE P802.15-03/0268r3, Multi-band OFDM Physical Layer Proposal for IEEE 802.15 Task Group 3a, May 2004.

UWB TimeSpreading



Description: UWB time domain spreader or despreader

Library: UWB, Multiplex

Class: SDFUWB_TimeSpreading

Parameters

Name	Description	Default	Unit	Type	Range
DataRate	Data rate: _53.3 Mbps, _55 Mbps, _80 Mbps, _106.67 Mbps, _110 Mbps, _160 Mbps, _200 Mbps, _320 Mbps, _400 Mbps, _480 Mbps	_53.3 Mbps		enum	
DataLength	Octet number of PSDU	100		int	[1:4095]
OperationType	Operation type: Spreading, Despreading	Spreading		enum	
PilotPN_Phase	Phase of pilot PN	0		int	[0:126]

Pin Inputs

Pin	Name	Description	Signal Type
1	Input	symbols to be time-(de)spread	complex

Pin Outputs

Pin	Name	Description	Signal Type
2	Output	time-(de)spread symbols	complex

Notes/Equations

1. This model is used to perform time-domain spreading operation before IFFT at the transmitter side and de-spreading operation after FFT at the receiver side.

For spreading, $N_u \times (N_{sym_{Header}} + N_{sym_{PSDU}})$ tokens are consumed at the Input pin,

$N_u \times (N_{sym_{Header-TSF}} + N_{sym_{PSDU-TSF}})$ tokens are produced at the Output pin, where N_u

is the number of used (both data and pilot, non-zero) sub-carriers in one OFDM symbol,

$N_{sym_{Header}} + N_{sym_{PSDU}}$ is the number of PLCP header and PSDU (OFDM) symbols before time-domain

spreading in one UWB MB-OFDM frame, $N_{sym_{Header-TSF}} + N_{sym_{PSDU-TSF}}$

is the number of PLCP header and PSDU symbols after time-domain spreading in one UWB MB-OFDM frame. For

de-spreading, $N_u \times (N_{sym_{Header-TSF}} + N_{sym_{PSDU-TSF}})$ tokens are consumed at the Input pin,

$N_u \times (N_{sym_{Header}} + N_{sym_{PSDU}})$ tokens are produced at the Output pin.

- Parameter DataRate and DataLength are used to determine the number of OFDM symbols per frame. In addition, DataRate is used to determine the time-domain spreading parameters such as conjugate symmetric input to IFFT, time spreading factor, etc. Please refer to the following table for details.

Rate-dependent parameters

Data Rate (Mb/s)	Modulation	Coding rate (R)	Frequency-Domain Spreading (FDS)	Time-Domain Spreading (TDS)	Coded bits / 6 OFDM symbol (NCBP6S)	Info bits / 6 OFDM symbol (NIBP6S)
53.3	QPSK	1/3	Yes	Yes	300	100
55*	QPSK	11/32	Yes	Yes	300	103.125
80	QPSK	1/2	Yes	Yes	300	150
106.7	QPSK	1/3	No	Yes	600	200
110*	QPSK	11/32	No	Yes	600	206.25
160	QPSK	1/2	No	Yes	600	300
200	QPSK	5/8	No	Yes	600	375
320	DCM	1/2	No	No	1200	600
400	DCM	5/8	No	No	1200	750
480	DCM	3/4	No	No	1200	900

*the data rate is not defined in the WiMedia PHY specification

For PLCP Header, the data rate is 53.3 Mb/s,

$$N_{sym_{Header}} = 6$$

$$N_{sym_{Header-TSF}} = 1;$$

for PSDU,

$$N_{sym_{PSDU}} = \frac{6}{TSF} \times \left\lceil \frac{8 \times DataLength + 32 + 6}{N_{IBP6S}} \right\rceil$$

1. "Multiband OFDM Physical Layer Specification", WiMedia Alliance document, Release 1.1, July 14, 2005.

UWB TimeSpreadingMR



Description: UWB time domain spreader or despreader (maximum ratio combination)

Library: UWB, Multiplex

Class: SDFUWB_TimeSpreadingMR

Parameters

Name	Description	Default	Unit	Type	Range
DataRate	Data rate: _53.3 Mbps, _55 Mbps, _80 Mbps, _106.67 Mbps, _110 Mbps, _160 Mbps, _200 Mbps, _320 Mbps, _400 Mbps, _480 Mbps	_53.3 Mbps		enum	
DataLength	Octet number of PSDU	100		int	[1:4095]
OperationType	Operation type: Spreading, Despreading	Despreading		enum	
PilotPN_Phase	Phase of pilot PN	0		int	[0:126]

Pin Inputs

Pin	Name	Description	Signal Type
1	Input	symbols to be time-(de)spread (equalized symbol in de-spreading operation)	complex
2	CFR	channel frequency-domain	complex

Advanced Design System 2008

		response (should be left unconnected in spreading operation)	
--	--	--	--

Pin Outputs

Pin	Name	Description	Signal Type
3	Output	time-(de)spread symbols (for de-spreading operation, MR combined symbol, similar with input)	complex
4	CFROut	channel frequency-domain response output $\sqrt{h_1^2 + h_2^2}$ (no use in spreading operation)	complex

Notes/Equations

- This model is used to perform time-domain spreading operation before IFFT at the transmitter side and de-spreading operation after FFT at the receiver side.

For spreading, only the Input pin and the Output pin shall be used, each firing,

$N_u \times (N_{sym_{Header}} + N_{sym_{PSDU}})$ tokens are consumed at the Input pin,

$N_u \times (N_{sym_{Header-TSF}} + N_{sym_{PSDU-TSF}})$ tokens are produced at the Output pin, where N_u is the number of used (both data and pilot, or non-zero) sub-carriers in one OFDM symbol,

$N_{sym_{Header}} + N_{sym_{PSDU}}$ is the number of PLCP header and PSDU (OFDM) symbols before time-domain spreading in one UWB MB-OFDM frame, $N_{sym_{Header-TSF}} + N_{sym_{PSDU-TSF}}$ is the number of PLCP header and PSDU symbols after time-domain spreading in one UWB MB-OFDM frame.

For de-spreading, $N_u \times (N_{sym_{Header-TSF}} + N_{sym_{PSDU-TSF}})$ tokens are consumed at the CFR pin and the Input pin, $N_u \times (N_{sym_{Header}} + N_{sym_{PSDU}})$ tokens are produced at the CFROut pin and the Output pin.

- Parameter DataRate and DataLength are used to determine the number of OFDM symbols per frame. In addition, DataRate is used to determine the time-domain spreading parameters such as conjugate symmetric input to IFFT, time spreading factor, etc. Please refer to the following table for details.

Rate-dependent parameters

Data Rate (Mb/s)	Modulation	Coding rate (R)	Frequency-Domain Spreading (FDS)	Time-Domain Spreading (TDS)	Coded bits / 6 OFDM symbol (NCBP6S)	Info bits / 6 OFDM symbol (NIBP6S)
53.3	QPSK	1/3	Yes	Yes	300	100

for data rates of 106.7, 110, 160 and 200Mbps,

$$C'_n(l) = C_n(N_u - 1 - l) \cdot p_{\text{mod}(n+6, 127)} \quad ;$$

for data rates of 320, 400 and 480Mbps, no time-domain spreading is applied;

where n=0 shall correspond to the first OFDM symbol following the PLCP preamble, and the value of the index n is OFDM symbol number before time spreading.

5. The time-domain de-spreading operation is implemented in frequency domain at the receiver side. Assume the equalized lth sub-carrier in the nth received OFDM symbol is represented by $C_n(l)$, the repeated version of this OFDM symbol is represented by $C'_n(l)$, the corresponding channel frequency domain response are $H_n(l)$ and $H'_n(l)$, then the de-spread version of $C_n(l)$ and $H_n(l)$, represented by $C_{\text{merged}_n}(l)$ and $H_{\text{merged}_n}(l)$, shall be obtained as follows with maximum ratio (MR) combination:

for data rates of 53.3, 55 and 80Mbps (PLCP header is of 53.3Mbps),

$$C_{\text{merged}_n}(l) = \frac{C_n(l) \cdot |h_n(l)|^2 + C'_n(l) \cdot |h'_n(l)|^2}{|h_n(l)|^2 + |h'_n(l)|^2} \quad ;$$

$$H_{\text{merged}_n}(l) = \sqrt{|h_n(l)|^2 + |h'_n(l)|^2} \quad ;$$

for data rates of 106.7, 110, 160 and 200Mbps,

$$C_{\text{merged}_n}(l) = \frac{C_n(l) \cdot |h_n(l)|^2 + [\text{imag}(C'_n(N_u - 1 - l)) + j \cdot \text{real}(C'_n(N_u - 1 - l))] \cdot |h'_n(N_u - 1 - l)|^2}{|h_n(l)|^2 + |h'_n(N_u - 1 - l)|^2} \quad ;$$

$$H_{\text{merged}_n}(l) = \sqrt{|h_n(l)|^2 + |h'_n(N_u - 1 - l)|^2} \quad ;$$

for data rates of 320, 400 and 480Mbps, no time-domain de-spreading is applied;

where n=0 shall correspond to the first OFDM symbol following the PLCP preamble, and the value of the index n is OFDM symbol number without time spreading.

References

1. "Multiband OFDM Physical Layer Specification", WiMedia Alliance document, Release 1.1, July 14, 2005.

Receiver Components

UWB ChEstimator



Description: UWB channel estimator

Library: UWB, Receiver

Class: SDFUWB_ChEstimator

Parameters

Name	Description	Default	Unit	Type	Range
TFC_Number	Time frequency code: TFC1, TFC2, TFC3, TFC4, TFC5, TFC6, TFC7	TFC1		enum	

Pin Inputs

Pin	Name	Description	Signal Type
1	input	received frequency-domain training sequence	complex

Pin Outputs

Pin	Name	Description	Signal Type
2	Coef	channel impulse response	complex

Notes/Equations

1. The model is used to estimate the channel impulse response by comparing the received frequency-domain OFDM training sequence with the original training sequence. The schematic for UWB_ChEstimator is shown in the following figure.

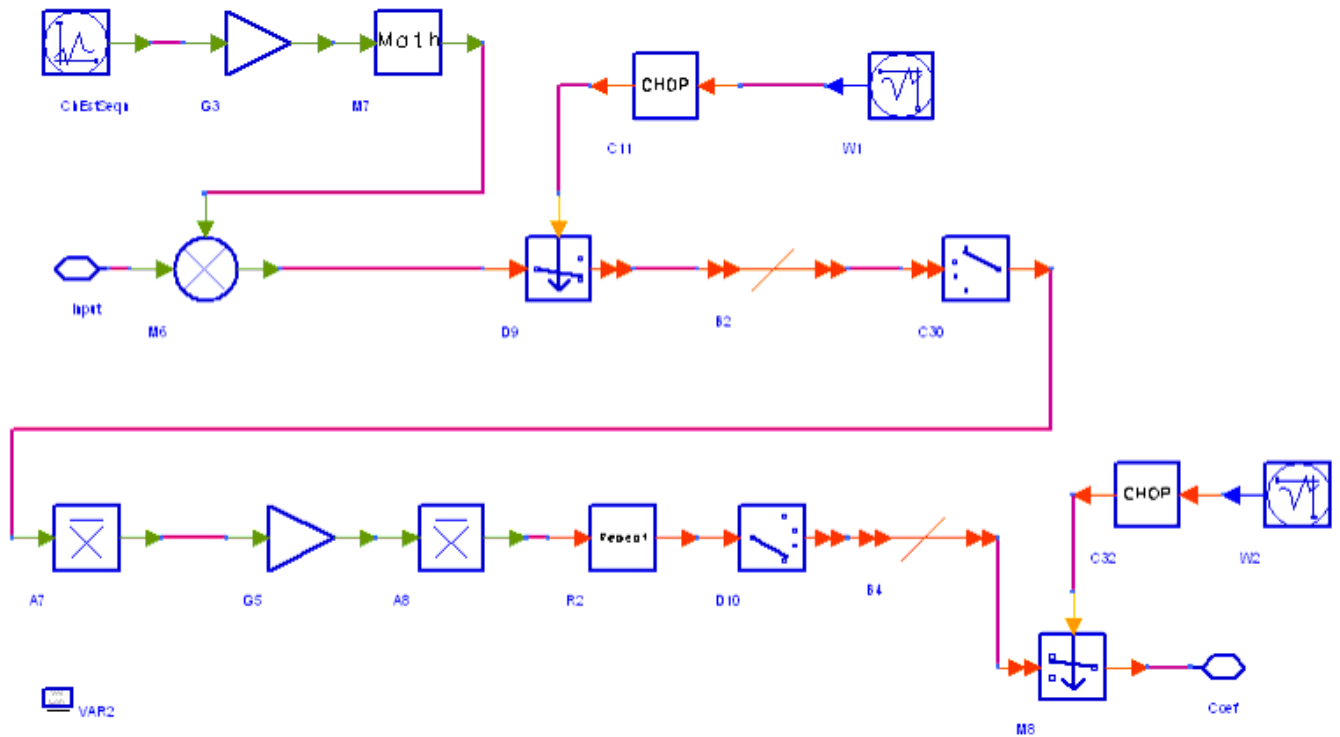

UWB_ChEstimator Schematic

2. The CIR h_i for the i th subcarrier can be easily obtained by

$$h_i = \frac{x_i}{L_i}$$

where x_i is the received training sequence on the i th subcarrier and L_i is the original training sequence.

3. The channel estimation training sequence includes 6 identical OFDM symbols, so the estimation accuracy can be improved by averaging estimated CIRs on the same sub-band. The DeMux and Bus components are used to separate and collect the h_i for each sub-band, and then it is averaged and Mux back to the 6 OFDM symbols.

References

1. "Multiband OFDM Physical Layer Specification", WiMedia Alliance document, Release 1.1, July 14, 2005.

UWB Demapper

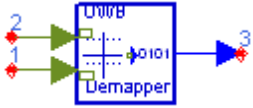

Description: UWB Constellation Demapper

Library: UWB, Receiver

Class: SDFUWB_Demapper

Parameters

Name	Description	Default	Type
DataRate	Data rate: _53.3 Mbps, _55 Mbps, _80 Mbps, _106.67 Mbps, _110 Mbps, _160 Mbps, _200 Mbps, _320 Mbps, _400 Mbps, _480 Mbps	_53.3 Mbps	enum
OutputType	whether a positive value or a negative value represents logic 1: Positive_for_1, Negative_for_1	Positive_for_1	enum

Pin Inputs

Pin	Name	Description	Signal Type
1	Input	equalized complex number to be demapped on each subcarrier	complex
2	CSI	frequency domain response of transmission channel on each subcarrier	complex

Pin Outputs

Pin	Name	Description	Signal Type
3	Output	soft bit for viterbi decoder	real

Notes/Equations

1. This model is used to de-map the equalized constellation signal into Non Return to Zero (NRZ) soft bits used for de-interleaver and convolutional decoder. Here soft bit is a measure of how likely it is that the bit is a 0 or 1 rather than the certain value of 0 or 1.
2. Each firing, ND (number of data sub-carriers in an OFDM symbol) tokens are consumed at the Input pin and CSI

pin, and NCBPS (coded bits per OFDM symbol) bits are generated at the Output pin, where
 $N_D=100$;

NCBPS=100, if data rate is equal to or less than 80 Mb/s;

NCBPS=200, if data rate is greater than 80Mb/s.

Data fed into the Input pin should be equalized constellation signals, and data fed into the CSI pin should be frequency response of the transmission channel on each sub-carrier.

3. We assume input constellations are represented by $\{d[k]\}$, channel frequency response are represented by $\{h[k]\}$, output soft bits are $\{b[i]\}$, where $k=0, 1, 2, \dots, N_D-1, i=0, 1, 2, \dots, \text{NCBPS}-1$.

For data rates equal to or less than 80 Mb/s,

firstly, de-spreading is applied which combines two constellations (represented by $d[k]$ and $d[N_D-1-k]$) on symmetrical sides of the DC sub-carrier to one constellation.

$$d_{combined}[k] = \frac{d[k] \cdot |h[k]|^2 + d[N_D-1-k] \cdot |h[N_D-1-k]|^2}{|h[k]|^2 + |h[N_D-1-k]|^2}, k = 0, 1, \dots, N_D/2 - 1$$

Accordingly, channel frequency responses are also combined in another way.

$$h_{combined}[k] = |h[k]|^2 + |h[N_D-1-k]|^2, k = 0, 1, \dots, N_D/2 - 1$$

Each combined constellation is de-mapped into two float values. After multiplying weight factor derived from the combined channel response with the two float values, two soft bits on the constellation (or carried on the two symmetrical sub-carriers) are obtained.

$$\left. \begin{array}{l} d[k], d[N_D-1-k] \\ h[k], h[N_D-1-k] \end{array} \right\} \rightarrow \left. \begin{array}{l} d_{combined}[k] \\ h_{combined}[k] \end{array} \right\} \rightarrow \{b[2k+0], b[2k+1]\}, k = 0, 1, \dots, N_D/2 - 1$$

For data rates equal to or less than 200Mb/s and greater than 80Mb/s, the de-mapping procedure is the same as that for data rates no higher than 80Mb/s except the bypass of frequency de-spreading (constellation combination).

$$\left. \begin{array}{l} d[k] \\ h[k] \end{array} \right\} \rightarrow \{b[2k+0], b[2k \times 2 + 1]\}, k = 0, 1, \dots, N_D - 1$$

For data rates equal to or less than 480Mb/s and greater than 200Mb/s, 4 bits are carried by two 16-QAM constellations (or DCM constellations, represented by $d[k]$ and $d[k+50]$). Joint de-mapping and combining are applied on the DCM constellations to obtain 4 soft bits.

$$\left. \begin{array}{l} d[k], d[k+50] \\ h[k], h[k+50] \end{array} \right\} \rightarrow \{b[2k+0], b[2k+1], b[2k+50], b[2k+51]\}, k = 0, 1, \dots, 24$$

$$\left. \begin{array}{l} d[k], d[k+50] \\ h[k], h[k+50] \end{array} \right\} \rightarrow \{b[2k+50], b[2k+51], b[2k+100], b[2k+101]\}, k = 25, 26, \dots, 49$$

4. Parameter OutputType is used to select whether a positive value or a negative value represents logic 1.

References

1. "Multiband OFDM Physical Layer Specification", WiMedia Alliance document, Release 1.1, July 14, 2005.

UWB DemuxFrame

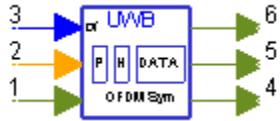

Description: UWB frame de-multiplexer with frequency offset compensation, cyclic prefix and guard interval removed

Library: UWB, Receiver

Class: SDFUWB_DemuxFrame

Parameters

Name	Description	Default	Unit	Type	Range
DataRate	Data rate: _53.3 Mbps, _55 Mbps, _80 Mbps, _106.67 Mbps, _110 Mbps, _160 Mbps, _200 Mbps, _320 Mbps, _400 Mbps, _480 Mbps	_53.3 Mbps		enum	
DataLength	Octet number of PSDU	100		int	[1:4095]
PreambleFormat	PLCP preamble format: Standard Format, Burst Format	Standard Format		enum	
OversamplingOption	Oversampling ratio: Ratio 1, Ratio 2, Ratio 4, Ratio 8, Ratio 16, Ratio 32	Ratio 2		enum	
Bandwidth	Bandwidth	528 MHz	Hz	real	(0, ∞)
CyclicPrefix	Cyclic prefix with zero padding	70.08 nsec	sec	real	[0, ∞)
GuardInterval	Guard interval	0.0 nsec	sec	real	[0, ∞)

	with zero padding				
IdleInterval	Idle Interval	0.0 nsec	sec	real	[0, ∞)
FreqOffset	Actual frequency offset	0.0	Hz	real	(∞, ∞)
DelaySpreadRatio	Multipath time delay spread relative to zero-padded suffix duration	3/4	Hz	real	[0,1]

Pin Inputs

Pin	Name	Description	Signal Type
1	input	received frame signals	complex
2	index	synchronization index	int
3	DeltaF	carrier frequency offset	real

Pin Outputs

Pin	Name	Description	Signal Type
4	CE	six channel estimate sequences	complex
5	output	PLCP Header and PSDU OFDM signals	complex
6	frame	Preamble, PLCP Header and PSDU OFDM signals	complex

Notes/Equations

1. This model is used to de-multiplex the received frame signals into one channel estimate sequence (six OFDM symbols), the concatenation of PLCP Header and PSDU OFDM signals, and the whole burst without idle interval; moreover, the cyclic prefix and guard interval are removed, time offset and carrier frequency offset are also compensated before de-multiplexing.

Each firing,

$$N_{total} = [S_{idle} + (128 + S_{CP} + S_{GI}) \cdot (N_{sync} + N_{hdr} + N_{frame})] \cdot 2^{OversamplingOption}$$

tokens are consumed at the input pin,

1 token is consumed at the index pin and the DeltaF pin,

$$128 \cdot N_{ce} \cdot 2^{OversamplingOption}$$

$$128 \cdot (N_{hdr} + N_{frame}) \cdot 2^{OversamplingOption}$$

tokens are produced at the output pin, and

$$[(128 + S_{CP} + S_{GI}) \cdot (N_{sync} + N_{hdr} + N_{frame})] \cdot 2^{OversamplingOption}$$

tokens are produced at the frame pin,

where

$$N_{sync} = \begin{cases} 30 & \text{StandardPreamble} \\ 18 & \text{BurstPreamble} \end{cases}$$

is the number of OFDM symbols in the PLCP Preamble,

$$N_{cc} = 6$$

is the number of OFDM symbols of channel estimation sequence in the PLCP Preamble,

$$N_{hdr} = 12$$

is the number of OFDM symbols in the PLCP Header,

$$N_{frame} = 6 \times \left\lceil \frac{[8 \times DataLength + 32 + 6]}{N_{IBP6S}} \right\rceil$$

is the number of OFDM symbols in the PSDU,

$$S_{idle} = \lfloor IdleInterval \cdot Bandwidth + 0.5 \rfloor$$

is the number of samples of the idle part between consecutive bursts at the sample rate of Bandwidth,

$$S_{CP} = \lfloor CyclicPrefix \cdot Bandwidth + 0.5 \rfloor$$

is the number of samples of the zero padded part in each OFDM symbol at the sample rate of Bandwidth,

$$S_{GI} = \lfloor GuardInterval \cdot Bandwidth + 0.5 \rfloor$$

is the number of samples of guard interval part in each OFDM symbol at the sample rate of Bandwidth, just similar with S_{CP} , and should be set 0 by default.

2. DataRate, PreambleFormat and DataLength parameters are used to determine the number of OFDM symbols per UWB MB-OFDM frame. Please refer to the following table for detail.

Rate-dependent parameters

Data Rate (Mb/s)	Modulation	Coding rate (R)	Frequency-Domain Spreading (FDS)	Time-Domain Spreading (TDS)	Coded bits / 6 OFDM symbol (NCBP6S)	Info bits / 6 OFDM symbol (NIBP6S)
53.3	QPSK	1/3	Yes	Yes	300	100
55*	QPSK	11/32	Yes	Yes	300	103.125
80	QPSK	1/2	Yes	Yes	300	150
106.7	QPSK	1/3	No	Yes	600	200
110*	QPSK	11/32	No	Yes	600	206.25
160	QPSK	1/2	No	Yes	600	300
200	QPSK	5/8	No	Yes	600	375

320	DCM	1/2	No	No	1200	600
400	DCM	5/8	No	No	1200	750
480	DCM	3/4	No	No	1200	900

*the data rate is not defined in the WiMedia PHY specification

- Because of the transmission delay, a detected frame usually falls into 2 consecutive received blocks, so the buffer length for input pin is $2 \times N_{total}$. The start point of the detected frame is determined by the input signal at the index pin. Only after receiving the second input block, this model can output one actual frame. So this model causes a fixed delay of one frame.
- Pin DeltaF inputs the estimated frequency offset (Δf_i) of each received frame. This estimated frequency offset must not effect the next frames in the frequency compensator. The FreqOffset parameter is set as the actual frequency offset between the transmitter and the receiver; when the ith frame is processed, the actual phase of previous i-1 frames is calculated and removed. The ith estimated frequency offset (Δf_i) compensates for the phase in the current frame only.
- Assume sequence $x_0, x_1, \dots, x_{2 \times N_{total} - 1}$ is signal from the input pin after removing the actual phase of previous i-1 frames caused by the actual frequency offset from FreqOffset parameter. $y_0, y_1, \dots, y_{2 \times N_{total} - 1}$ are the sequences, whose phase caused by frequency offset, are removed:

$$y_k = x_k \times e^{-j2\pi\Delta f_i k T_{Step}}$$

where

$$\Delta f_i$$

is frequency offset of the ith received frame, which is the input of the DeltaF pin,

is the sample time step (interval) of the input signal. When

$$T_{Step} = \frac{1}{Bandwidth \times 2^{OversamplingOption}}$$

frequency offset compensation is applied, the actual MB-OFDM frame with idle part being discarded will be output at the frame pin. the index pin inputs the start point of the detected MB-OFDM frame (including idle). The equation is:

$$z_k = y_{k + Index + N_{idle}} \quad k = 0, 1, \dots, N_{FFTpoint} \times N_{SYM} - 1$$

$z_0, z_1, \dots, z_{N_{FFTpoint} \times N_{SYM} - 1}$ sequences are output at frame pin.

- Parameter DelaySpreadRatio is used to optimize the synchronization window under fading channel. It should be the ratio of maximum multi-path delay spread to 1/4 of an OFDM symbol duration (or 60.61ns).

References

- "Multiband OFDM Physical Layer Specification", WiMedia Alliance document, Release 1.1, July 14, 2005.

UWB FrameSync

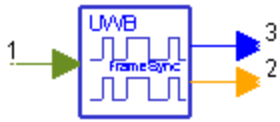

Description: UWB coarse timing synchronizer

Library: UWB, Receiver

Class: SDFUWB_FrameSync

Parameters

Name	Description	Default	Unit	Type	Range
DataRate	Data rate: _53.3 Mbps, _55 Mbps, _80 Mbps, _106.67 Mbps, _110 Mbps, _160 Mbps, _200 Mbps, _320 Mbps, _400 Mbps, _480 Mbps	_53.3 Mbps		enum	
DataLength	Octet number of PSDU	100		int	[1:4095]
PreambleFormat	PLCP preamble format: Standard Format, Burst Format	Standard Format		enum	
OversamplingOption	Oversampling ratio: Ratio 1, Ratio 2, Ratio 4, Ratio 8, Ratio 16, Ratio 32	Ratio 2		enum	
Bandwidth	Bandwidth	528 MHz	Hz	real	(0, ∞)
CyclicPrefix	Cyclic prefix with zero padding	70.08 nsec	sec	real	[0, ∞)
GuardInterval	Guard interval with zero padding	0.0 nsec	sec	real	[0, ∞)
IdleInterval	Idle Interval	0.0 nsec	sec	real	[0, ∞)
TFC_Number	Time frequency code: TFC1, TFC2, TFC3, TFC4, TFC5,	TFC1		enum	

	TFC6, TFC7				
SearchMode	Searching mode synchronization: EveryFrame, Once	EveryFrame		enum	
SearchWindow	Searching window synchronization	24		int	†

† The minimum value of this parameter should be the number of OFDM symbols in the synchronization sequences portion of the PLCP preamble, and the maximum value of this parameter should be the number of OFDM symbols in one MB-OFDM frame.

Pin Inputs

Pin	Name	Description	Signal Type
1	input	input signals for synchronization	complex

Pin Outputs

Pin	Name	Description	Signal Type
2	index	synchronization index	int
3	corr	correlation output	real

Notes/Equations

1. This model is used to implement the synchronization for UWB OFDM system.
Each firing, 1 token is produced at index pin; N_{total} tokens are produced at corr pin; N_{total} tokens are consumed at input pin. N_{total} is the number of samples in one frame.
2. The correlation values between the received and the reference signals, and the specific auto correlation values of the received signals are calculated for synchronization. The maximum correlation value is searched for and the corresponding index is selected as the frame start point. The frame start point is outputted at the index pin.
3. DataRate, PreambleFormat and DataLength parameters are used to determine the number of OFDM symbols per UWB-OFDM frame.
When the DataRate is set, the data rate-dependent parameters such as modulation, coding rate, frequency spreading factor, time spreading factor, and information bits per 6 OFDM symbol (N IBP6S) will be set according to the specification. Please refer to the following table for detail.

Rate-dependent Parameters

Advanced Design System 2008

Data Rate (Mb/s)	Modulation	Coding rate (R)	Frequency-Domain Spreading (FDS)	Time-Domain Spreading (TDS)	Coded bits / 6 OFDM symbol (NCBP6S)	Info bits / 6 OFDM symbol (NIBP6S)
53.3	QPSK	1/3	Yes	Yes	300	100
55*	QPSK	11/32	Yes	Yes	300	103.125
80	QPSK	1/2	Yes	Yes	300	150
106.7	QPSK	1/3	No	Yes	600	200
110*	QPSK	11/32	No	Yes	600	206.25
160	QPSK	1/2	No	Yes	600	300
200	QPSK	5/8	No	Yes	600	375
320	DCM	1/2	No	No	1200	600
400	DCM	5/8	No	No	1200	750
480	DCM	3/4	No	No	1200	900

* denotes the data rate which the new specification is not defined

The following figure shows the format for the PLCP frame including three parts: the PLCP preamble, PLCP header (PHY header, MAC header, header check sequence, tail bits, Reed-Solomon parity bits and tail bits), MAC frame body (frame payload plus FCS, tail bits, and pad bits).

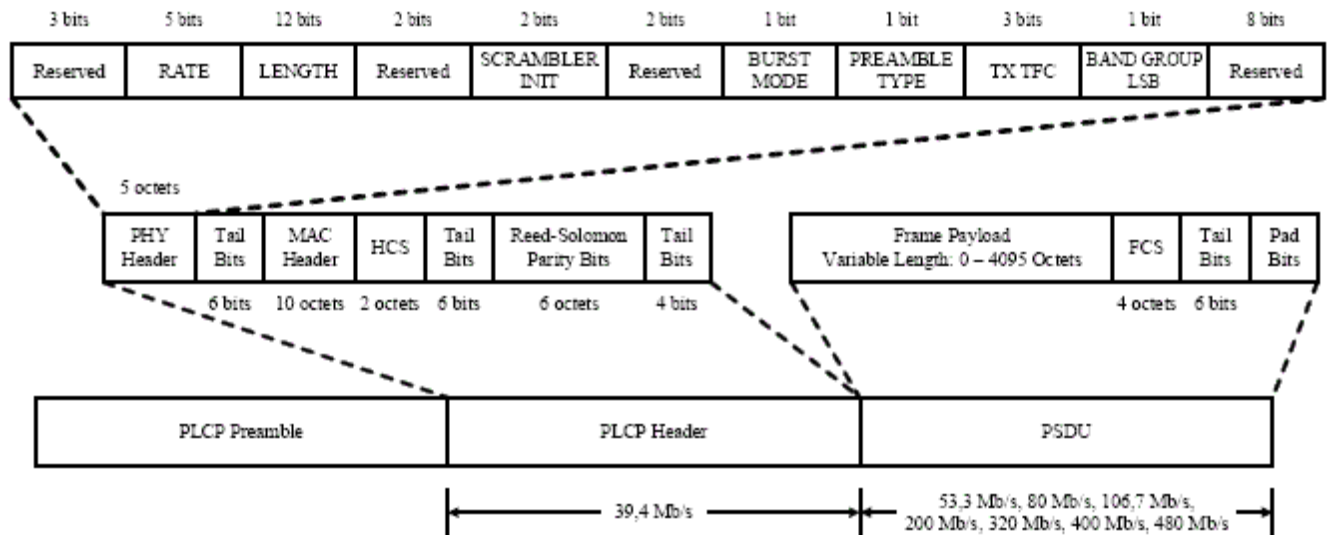

PLCP frame format.

The PLCP preamble consists of two portions: the packet/frame synchronization sequence and the channel

estimation sequence. There are 24 or 12 OFDM symbols in the time domain synchronization sequence portion for Standard preamble or Burst preamble, respectively:

$$N_{sym_{TimeSeq}} = \begin{cases} 24 & \text{Standard} \\ 12 & \text{Burst} \end{cases}$$

The frequency domain channel estimation portion of the preamble is constructed by successively appending 6 periods of an OFDM training sequence. That is $N_{sym_{FreqSeq}} = 6$.

So, there are 30 and 18 OFDM symbols for Standard preamble and Burst preamble, respectively.

$$N_{sym_{Preamble}} = N_{sym_{TimeSeq}} + N_{sym_{FreqSeq}} = \begin{cases} 30 & \text{Standard} \\ 18 & \text{Burst} \end{cases}$$

The preceding figure shows the PLCP Header, which consists of 200 bits. After convolutional code, mapping, and time spreading, the OFDM symbols of PLCP Header is:

$$N_{sym_{Header}} = 12$$

MAC frame body consists of frame payload, FCS, tail bits, and pad bits. The OFDM symbols of PSDU after time-domain spreading is computed as follows:

$$N_{sym_{PSDU}} = 6 \times \left\lceil \frac{8 \times DataLength + 38}{N_{IBP6S}} \right\rceil$$

Where N_{IBP6S} are determined by the data rate. Please refer to the preceding table for detail.

The number of pad bits is:

$$N_{pad} = N_{IBP6S} \times \left\lceil \frac{8 \times DataLength + 38}{N_{IBP6S}} \right\rceil - (8 \times DataLength + 38)$$

So, the total number of OFDM symbols N_{SYM}

per UWB-OFDM frame is: $N_{SYM} = N_{sym_{Preamble}} + N_{sym_{Header}} + N_{sym_{PSDU}}$

4. PreambleFormat and TFC_Number are used to determine the packet/frame synchronization sequence of the PLCP preamble.

The structure of the PLCP preamble is shown in the following figure.

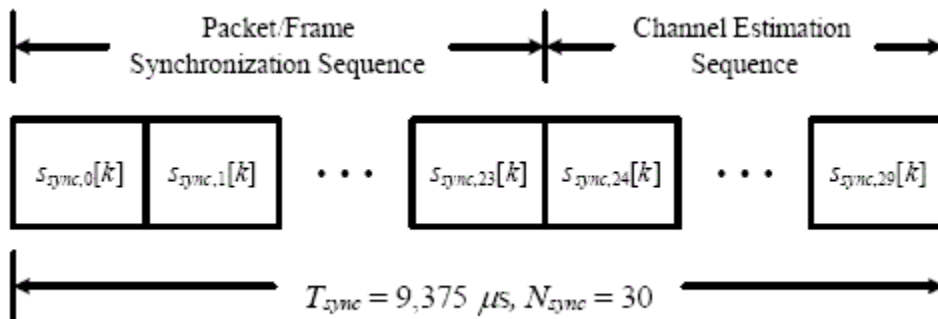

(a) Block diagram of the standard PLCP preamble

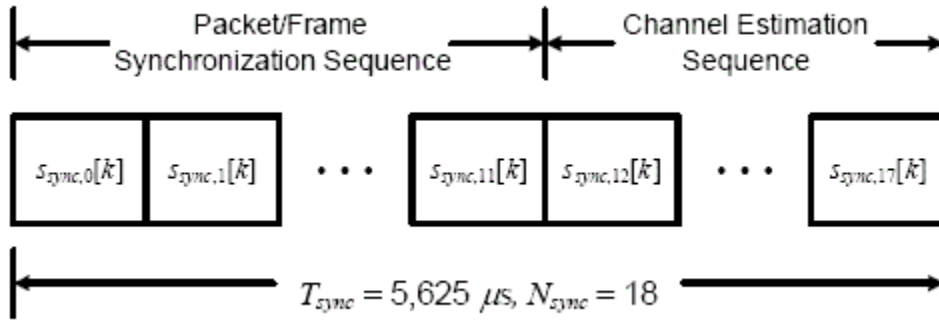

(b) Block diagram of the burst PLCP preamble

Block diagram of the PLCP preamble

The packet/frame synchronization sequence shall be structured as shown in the following figure:

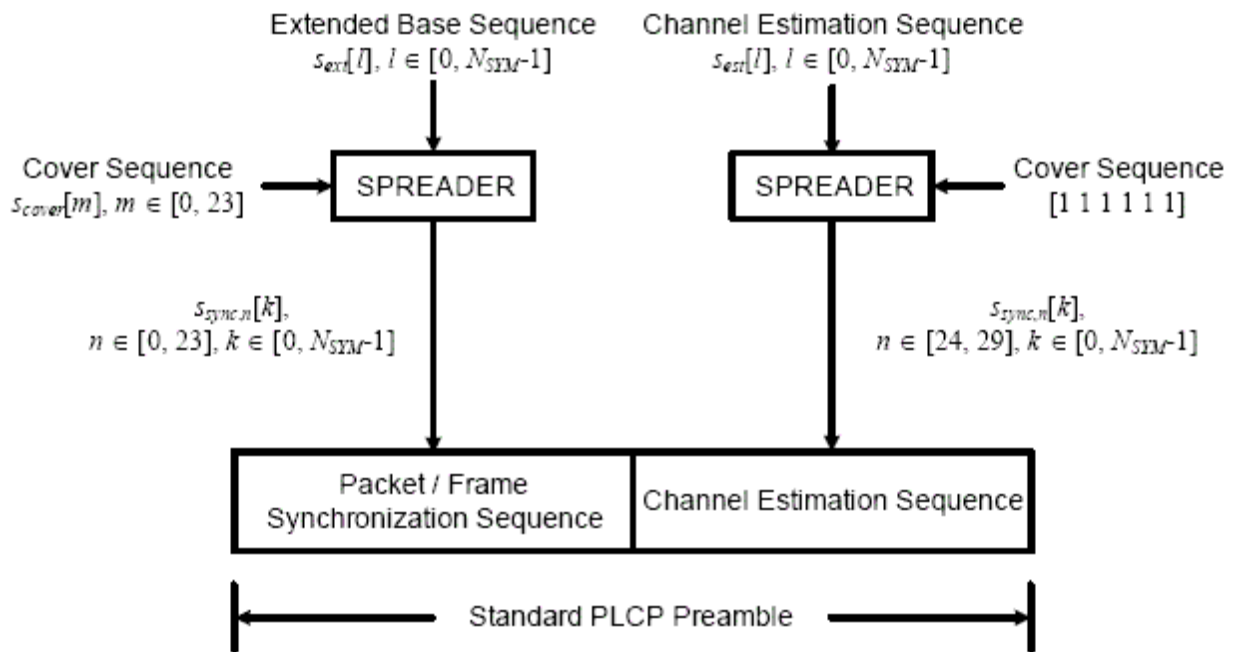

(a) Block diagram of the standard PLCP preamble construction

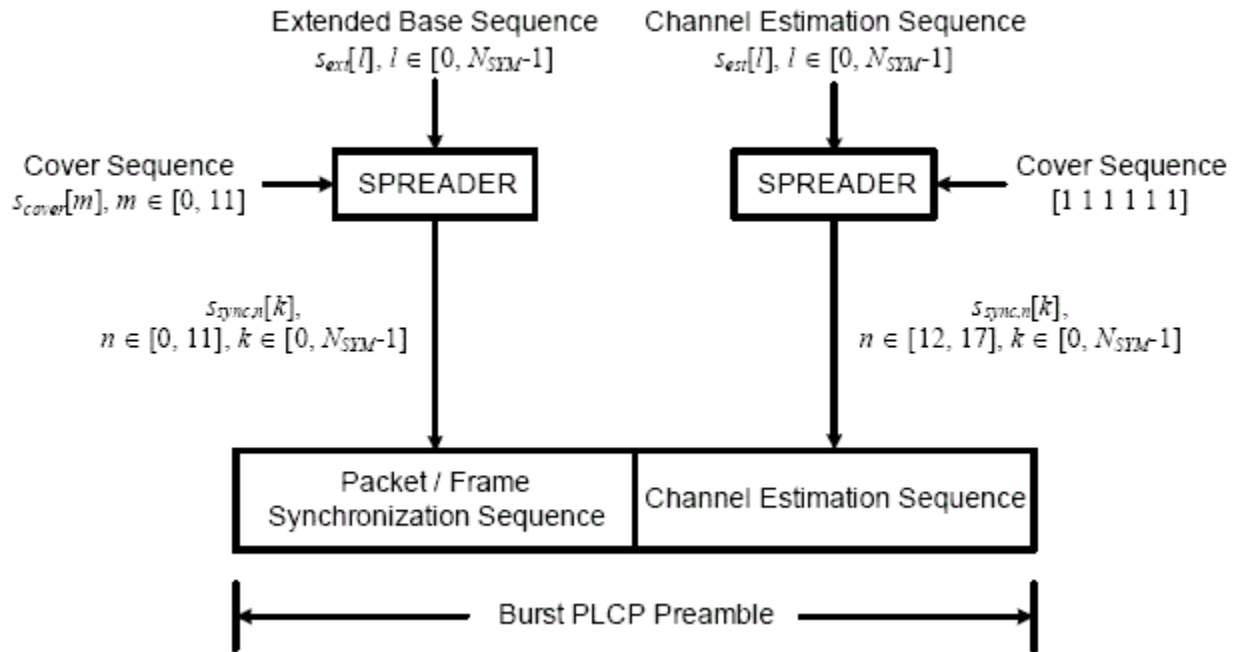

(b) Block diagram of the burst PLCP preamble construction

Block diagram of PLCP preamble construction

- For a given time-frequency code, select the appropriate base time-domain sequence $s_{base}[l]$ from Table 6-4 through Table 6-10 of reference [1] and the appropriate cover sequence $s_{cover}[m]$. The cover sequence is decided by the PreambleFormat and the TFC_Number as shown in the following table and the cover sequences for the time preamble are defined in the second of the following two tables.
- Form an extended time-domain sequence $s_{ext}[l]$ by appending N_{ZPS} "zeros samples" to the length N_{FFT} sequence $s_{base}[l]$.
- The k^{th} sample of the n^{th} symbol in the preamble $s_{sync,n}[k]$, corresponding to the packet/frame synchronization sequence, is given by: $s_{sync,n}[k] = s_{cover}[n] \times s_{ext}[k]$, where $n \in [0, N_{pf} - 1]$, $k \in [0, N_{SYMP} - 1]$, N_{pf} is the number of symbols in the packet/frame synchronization sequence (Standard preamble: 24 / Burst preamble:12) and N_{SYMP} is the number of samples per symbol.

The packet/frame synchronization sequence can be used for packet detection and acquisition, coarse carrier frequency estimation, and coarse symbol timing.

Finally, the channel estimation portion of the preamble, denoted as {CE0, CE1, ... CE5}, shall be constructed by successively appending 6 periods of an OFDM training sequence.

Time Frequency Codes and associated Preamble Patterns

TFC Number	Preamble Pattern Number	Cover Sequence Number
------------	-------------------------	-----------------------

Advanced Design System 2008

1	1	1
2	2	1
3	3	2
4	4	2
5	5	3
6	6	3
7	7	3

Cover sequence for standard preamble

m	Scover[m] for TFC 1,2	Scover[m] for TFC 3,4	Scover[m] for TFC 5,6,7
0	1	1	-1
1	1	1	-1
2	1	1	-1
3	1	1	-1
4	1	1	-1
5	1	1	-1
6	1	1	-1
7	1	1	1
8	1	1	-1
9	1	1	-1
10	1	1	1
11	1	1	-1
12	1	1	-1
13	1	1	1
14	1	1	-1
15	1	1	-1
16	1	1	1
17	1	1	-1
18	1	1	-1
19	1	-1	1

20	1	1	-1
21	-1	-1	1
22	-1	1	1
23	-1	-1	1

Cover sequence for burst preamble

m	Scover[m] for TFC 1,2	Scover[m] for TFC 3,4	Scover[m] for TFC 5,6,7
	1	1	-1
1	1	1	-1
2	1	1	-1
3	1	1	1
4	1	1	1
5	1	1	-1
6	1	1	-1
7	1	-1	1
8	1	1	-1
9	-1	-1	1
10	-1	1	1
11	-1	-1	1

5. OversamplingOption, Bandwidth, CyclicPrefix and GuardInterval are used for calculating the number of samples in one OFDM symbol period. The number of samples for one OFDM symbol (N) is computed as follows:

$$N = 2^{\text{OversamplingOption}} \times (128 + \text{Bandwidth} \times (\text{CyclicPrefix} + \text{GuardInterval}))$$

The number of samples in one FFT period ($N_{FFTpoint}$) is computed as follows:

$$N_{FFTpoint} = 2^{\text{OversamplingOption}} \times 128$$

6. IdleInterval is used to simulate the arbitrary time interval between two UWB packets.

The length of Idle (N_{idle}) can be computed as follows:

$$N_{idle} = \text{IdleInterval} \times \text{Bandwidth} \times 2^{\text{OversamplingOption}}$$

After determining N_{SYM} , N and N_{idle} , the length of one MB-OFDM frame (N_{total}) can be calculated:

$$N_{total} = N \times N_{SYM} + N_{idle}$$

7. The SearchMode is used to set the searching mode, "EveryFrame" means searching every frame; "Once" means searching once in the entire simulation. The SearchWindow is used to set the number of symbols for searching.

It is in the unit of OFDM symbol. The minimum value should be 24 for standard preamble or 12 for shortened preamble, and the maximum value should be the number of OFDM symbols in a UWB frame.

References

1. "Multiband OFDM Physical Layer Specification", WiMedia Alliance document, Release 1.1, July 14, 2005.

UWB FreqSync



Description: UWB frequency synchronizer

Library: UWB, Receiver

Class: SDFUWB_FreqSync

Parameters

Name	Description	Default	Unit	Type	Range
BandGroup	BandGroup: BandGroup1, BandGroup2, BandGroup3, BandGroup4, BandGroup5, BandGroup6	BandGroup1		enum	
DataRate	Data rate: _53.3 Mbps, _55 Mbps, _80 Mbps, _106.67 Mbps, _110 Mbps, _160 Mbps, _200 Mbps, _320 Mbps, _400 Mbps, _480 Mbps	_53.3 Mbps		enum	
DataLength	Octet number of PSDU	100		int	[1:4095]
PreambleFormat	PLCP preamble format: Standard	Standard Format		enum	

Advanced Design System 2008

	Format, Burst Format				
TFC_Number	Time frequency code: TFC1, TFC2, TFC3, TFC4, TFC5, TFC6, TFC7	TFC1		enum	
OversamplingOption	Oversampling ratio: Ratio 1, Ratio 2, Ratio 4, Ratio 8, Ratio 16, Ratio 32	Ratio 2		enum	
Bandwidth	Bandwidth	528 MHz	Hz	real	(0, ∞)
CyclicPrefix	Cyclic prefix with zero padding	70.08 nsec	sec	real	[0, ∞)
GuardInterval	Guard interval with zero padding	0.0 nsec	sec	real	[0, ∞)
IdleInterval	Idle Interval	0.0 nsec	sec	real	[0, ∞)

Pin Inputs

Pin	Name	Description	Signal Type
1	input	received frame signals	complex
2	index	synchronization index	int

Pin Outputs

Pin	Name	Description	Signal Type
3	DeltaF	carrier frequency offset	real

Notes/Equations

1. This model is used to estimate the carrier frequency offset for the UWB receiver. The Schematic for UWB_FreqSync is shown in the following figure.

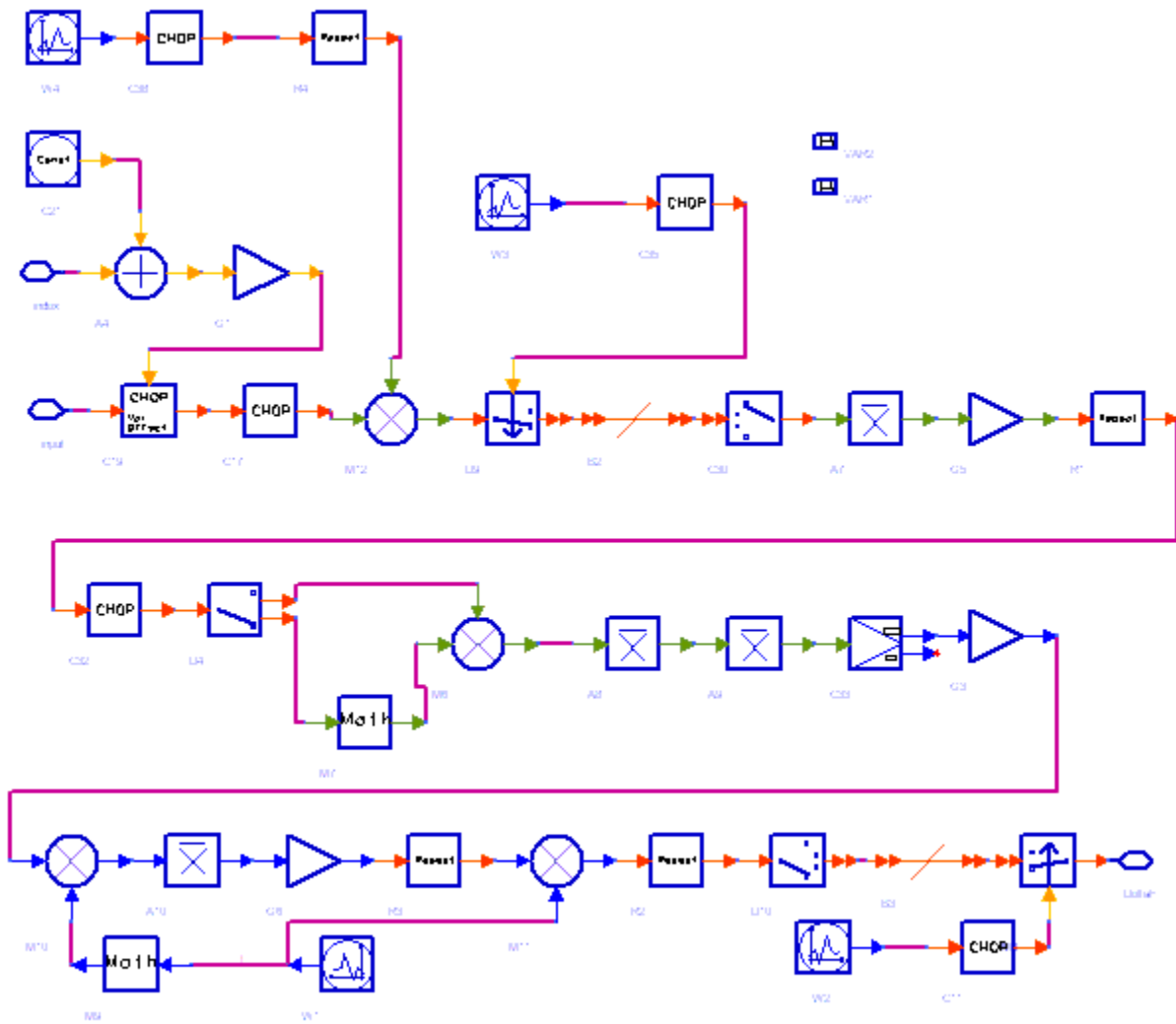

UWB_FreqSync Schematic

- The modulating signal for different sub-band is generated from the same clock oscillator, so the frequency offset for each sub-bands is correlated and can be used to estimate the same clock oscillator frequency offset. Assume that f_i is the carrier frequency for the i th sub-band and Δf_i is its frequency offset, f_o oscillator frequency and Δf_o is its offset, then $\Delta f_i/f_i = \Delta f_o/f_o$
- The input signal is time synonymized and separated to each sub-band. Then the i th sub-band phase offset, $\Delta\theta_i$, can be determined by correlating consecutive OFDM symbols and is averaged on the same sub-band.

$$\Delta\theta_i = \arg \left(\sum_{j=1}^{N-1} \sum_{k=1}^M x_j((j-1) \times M + k) \times x_j^*(j \times M + k) \right), i = 1 \dots N_b$$

where x_j is the received preamble samples sequence, N is the number of preambles OFDM symbols for each

sub-band, M is the number of samples per OFDM symbol except the GP and CP and N_b is the number of sub-bands.

Then frequency offset per Hz for the clock oscillator can be estimated by

$$(\Delta f_o)/f_o = \sum_{i=1}^{N_b} (\Delta \theta_i / 2\pi T) / f_i / N_b$$

where T is the time interval between two consecutive preamble OFDM symbols on the same sub-band.

Finally, the frequency offset is averaged over all the sub-band to improve the estimation accuracy.

$$\Delta f_i = f_i \times (\Delta f_o) / f_o, i = 1, \dots, N_b$$

References

1. "Multiband OFDM Physical Layer Specification", WiMedia Alliance document, Release 1.1, July 14, 2005.

UWB PhaseTracker



Description: UWB Phase tracker

Library: UWB, Receiver

Class: SDFUWB_PhaseTracker

Parameters

Name	Description	Default	Unit	Type	Range
DataRate	Data rate: _53.3 Mbps, _55 Mbps, _80 Mbps, _106.67 Mbps, _110 Mbps, _160 Mbps, _200 Mbps, _320 Mbps, _400 Mbps, _480 Mbps	_53.3 Mbps		enum	
DataLength	Octet number of	100		int	[1:4095]

Advanced Design System 2008

	PSDU				
PilotPN_Phase	Phase of pilot PN	10		int	[0:126]

Pin Inputs

Pin	Name	Description	Signal Type
1	input	all sub-carriers in one OFDM symbol	complex
2	CIR	estimated channel impulse response	complex

Pin Outputs

Pin	Name	Description	Signal Type
3	coef	channel coefficient in active subcarriers	complex
4	theta	phase difference between current CIR and estimated CIR	real

Notes/Equations

- The model is used to track the common phase shift of each OFDM symbol and output the update channel impulse response with the estimated phase shift compensation.

According to [Reference 1](#), in each OFDM symbol following the PLCP preamble, twelve of the subcarriers are dedicated to pilot signals in order to make coherent detection robust against frequency offsets and phase noise. these pilots single are in subcarriers numbered -55,-45,-35,-25,-15,-5,5,15,25,35,45 and 55. Assume $P(n, k)$ is the pilot on the n^{th} subcarrier for the k^{th} OFDM symbol and $CE(n)$ is the frequency-domain OFDM training sequence on the n^{th} subcarrier.

Then for data rate less than 110Mbps:

$$P(n, k) = CE(n), n = 5, 15, 25, 35, 45, 55$$

$$P(n, k) = conj(P(-n, k)), n = -5, -15, -25, -35, -45, -55$$

For data rate higher than 110Mbps:

$$P(n, k) = CE(n), n = 5, 15, 25, 35, 45, 55$$

$$P(n, k) = P(-n, k), n = -5, -15, -25, -35, -45, -55$$

The pilot subcarriers are further BPSK modulated by a pseudo-random binary sequence to prevent the generation of spectral lines.

- When the pilot signal is received, it is BPSK demodulated, de-conjugated and if necessary. Then channel estimation on the n^{th} subcarrier for the k^{th} symbol $CIR(n, k)$ can be obtained. Assume $CIR_{CE}(n)$ is the estimated channel impulse response on the n^{th} subcarrier, then the common phase shift for the k^{th} symbol can be estimated by

$$\hat{\phi}(k) = \arg\left(\sum_n CIR(n, k) \times conj(CIR_{CE}(n))\right)$$

- The output update channel impulse response for the k^{th}

OFDM symbol will be

$$CIR_{out}(n, k) = CIR_{CE}(n) \times e^{j\hat{\phi}(k)}$$

References

- "Multiband OFDM Physical Layer Specification", WiMedia Alliance document, Release 1.1, July 14, 2005.

UWB Receiver



Description: UWB receiver

Library: UWB, Receiver

Class: SDFUWB_Receiver

Parameters

Name	Description	Default	Unit	Type	Range
BandGroup	BandGroup: BandGroup1, BandGroup2,	BandGroup1		enum	

Advanced Design System 2008

	BandGroup3, BandGroup4, BandGroup5, BandGroup6				
DataRate	Data rate: _53.3 Mbps, _55 Mbps, _80 Mbps, _106.67 Mbps, _110 Mbps, _160 Mbps, _200 Mbps, _320 Mbps, _400 Mbps, _480 Mbps	_53.3 Mbps		enum	
DataLength	Octet number of PSDU	100		int	[1:4095]
PreambleFormat	PLCP preamble format: Standard Format, Burst Format	Standard Format		enum	
TFC_Number	Time frequency code: TFC1, TFC2, TFC3, TFC4, TFC5, TFC6, TFC7	TFC1		enum	
OversamplingOption	Oversampling ratio: Ratio 1, Ratio 2, Ratio 4, Ratio 8, Ratio 16, Ratio 32	Ratio 2		enum	
Bandwidth	Bandwidth	528 MHz	Hz	real	(0, ∞)
CyclicPrefix	Cyclic prefix with zero padding	70.08 nsec	sec	real	[0, ∞)
IdleInterval	Idle Interval	0.0 nsec	sec	real	[0, ∞)
ScramblerSeed	Scrambler seed selection: Seed 00, Seed 01, Seed 10, Seed 11	Seed 11		enum	
FreqOffset	Actual frequency offset	0.0	Hz	real	(∞, ∞)
SearchMode	Searching mode synchronization: EveryFrame, Once	EveryFrame		enum	

Advanced Design System 2008

SearchWindow	Searching window synchronization	24		int	†
--------------	----------------------------------	----	--	-----	---

†The minimum value of this parameter should be the number of OFDM symbols in the synchronization sequences portion of the PLCP preamble, and the maximum value of this parameter should be the number of OFDM symbols in one MB-OFDM frame.

Pin Inputs

Pin	Name	Description	Signal Type
1	input	received signal to be demodulated	complex

Pin Outputs

Pin	Name	Description	Signal Type
2	For_EVM	undemapped signal after FFT used for EVM	complex
3	UnDecodedBits	deinterleaved data bits before decoding	int
4	PSDUFCS	PSDU and FCS bits	int
5	PSDU	PSDU bits	int

Notes/Equations

1. This subnetwork model is used to implement baseband receiver algorithm for WiMedia MB-OFDM system following [Reference 1](#).
2. The schematic for UWB-OFDM baseband receiver is shown in the following figure.

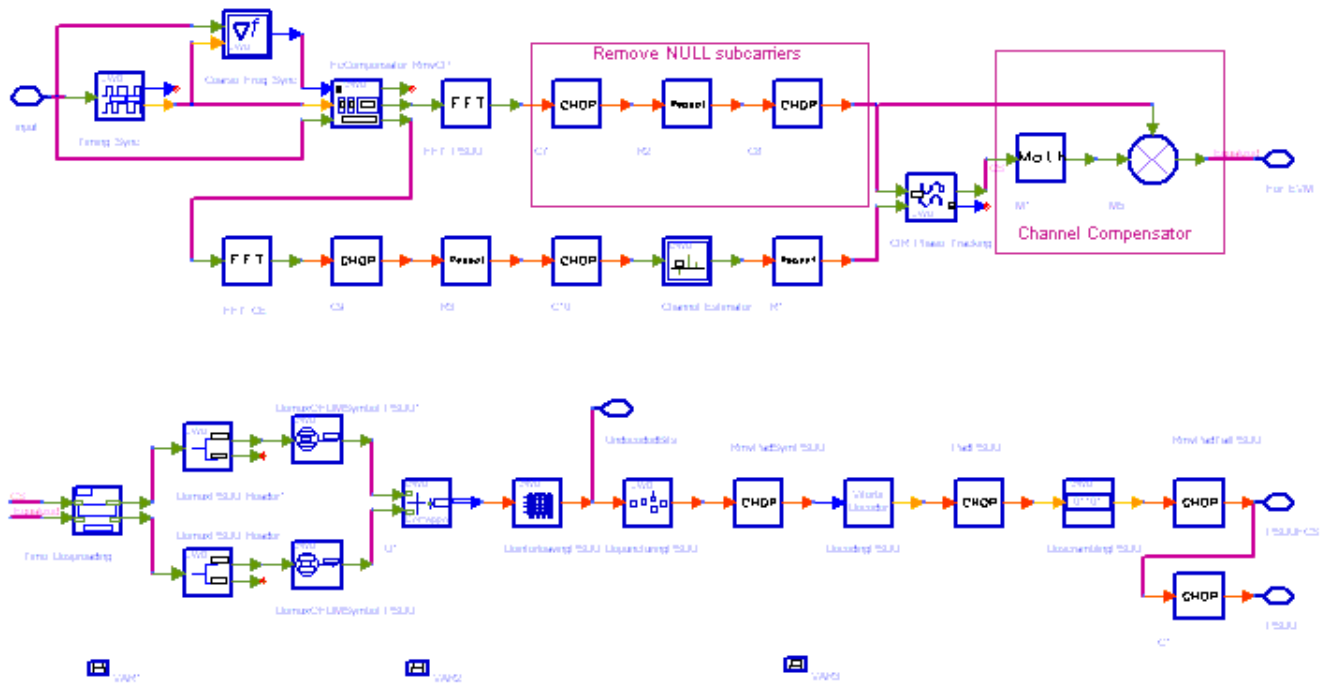

UWB_Receiver Schematic

Receiver functions are implemented as follows:

The start of frame is detected. UWB_FrameSync correlates the received signal with the preambles and selects the index with the maximum correlation value as the start of frame. The transition from time-domain sequence to channel estimation sequences is detected and timing (with one sample resolution) is established (packet synchronization). Then frequency offset for each sub-band is estimated by UWB_FreqSync with the time-domain sequence. The time and frequency offset are compensated by UWB_DemuxFrame, which outputs six channel estimation sequences and the OFDM symbols for PLCP Header and payload frame (PSDU) demodulation. The UWB_DemuxFrame component introduces one frame delay.

Channel response coefficients are estimated for each subcarrier (channel estimation) on each sub-band. The estimated channel response coefficients are duplicated to compensate the PLCP Header and frame payload in the same frame.

Each OFDM symbol is transformed into 122 subcarriers by FFT. Common phase variation of the pilot subcarriers are estimated, then all subcarrier values are de-rotated according to the estimated phase. UWB_PhaseTracker implements these functions.

Advanced Design System 2008

The received signal on each subcarrier is divided by the estimated channel response coefficient (phase tracking, phase synchronization, and equalization). This simple one-tap frequency domain channel response compensation method is an advantage of OFDM system.

After the one-tap frequency equalization, the demodulated OFDM symbols for PLCP Header and PSDU are outputs at pin For_EVM. The signal can be used to demonstrate the demodulated constellation and to calculate the EVM.

The equalized OFDM symbols of PLCP Header and frame payload are de-spread by UWB_TimeSpreading in De-spreading mode. 12 OFDM symbols of PLCP Header are de-spread to 6 OFDM symbols based on maximum ratio combination (MRC). According to the data rate of PSDU, the OFDM symbols of PSDU are also de-spread accordingly.

After de-spreading, OFDM symbols of PLCP Header and frame payload are de-multiplexed by UWB_DemuxDataPLCP. There are two branches of output: one is frame payload; another is PLCP Header. The PLCP Header de-mapping and decoding are not implemented in this release.

After de-spreading, UWB_DemuxOFDMSym de-multiplexes 122 subcarriers into 100 data subcarriers, 12 pilot subcarriers and 10 guard subcarriers. UWB_DemuxOFDMSym just outputs signal at 100 data subcarriers.

A QPSK/DCM demapper will then demap the the signal constellation to soft output bits with channel state information weighted.

After that, the frame payload bits are de-interleaved, decoded and de-scrambled.

The PSDU with FCS is the output at pin PSDUFCS and PSDU is the output at Pin PSDU, respectively.

The de-interleaved frame payload signal is the output at pin UndecodedBits, which is the signal before Viterbi decoding.

3. Parameter details

DataRate is for data rate of UWB-OFDM system. This release supports 53.3, 55, 80, 106.67, 110, 160, 200, 320,

400 and 480 Mb/s.

DataLength represents the bytes of PSDU (MAC frame body). Its value range is for 1 to 4095 bytes.

TFC_Number is for Time-frequency codes number, which controls the frequency hopping sequence (see Table 1).

PreambleFormat is used to select Standard PLCP or Shortened PLCP preamble format defined in UWB-OFDM.

OversamplingOption indicates the oversampling ratio of transmission signal. There are seven oversampling ratios (1, 2, 4, 8, 16, 32, 64) to support in this receiver. For example, if OversamplingOption = Ratio 2, it means the IFFT size is 256.

Bandwidth specifies the spectrum bandwidth of UWB-OFDM. The default value is 528 MHz.

CyclicPrefix and IdleInterval are defined as cyclic prefix duration time and idle interval duration time. The default value for CyclicPrefix and GuardInterval are 70.08 nsec and 0 nsec.

ScramblerSeed is to select the seed identifier. And the seed identifier controls 15 bit initialization vector. Please note, the receiver has a fixed one frame delay. So, the values of ScramblerSeed in UWB-OFDM signal source (UWB_SignalSource, UWB_SignalSource_RF and UWB_Source_FH_RF) and receiver (UWB_Receiver, UWB_Receiver_RF and UWB_Receiver_FH_RF) should be the two consecutive values. Only above setting can get right BER (Bit Error Rate). For examples, ScramblerSeed =Seed 00 in UWB-OFDM signal source; ScramblerSeed = Seed 11 in UWB-OFDM receiver.

PilotPN_Phase is to set the start phase of pilot (PRBS). The specification requires PilotPN_Phase=0.

References

1. "Multiband OFDM Physical Layer Specification", WiMedia Alliance document, Release 1.1, July 14, 2005.

UWB Receiver FH RF



Description: UWB RF frequency hopping receiver

Library: UWB, Receiver

Class: TSDFUWB_Receiver_FH_RF

Parameters

Name	Description	Default	Unit	Type	Range
RLoad	Input resistance	DefaultRLoad	Ohm	real	(0, ∞)
RTemp	Temperature	DefaultRTemp	Celsius	real	[-273.15, ∞)
GainImbalance	Gain imbalance, Q vs I	0.0	dB	real	(∞, ∞)
PhaseImbalance	Phase imbalance, Q vs I	0.0	deg	real	(∞, ∞)
Sensitivity	voltage output sensitivity, Vout/Vin	1		real	(∞, ∞)
Delay	Frequency synthesizer delay	1.8939 nsec	sec	real	[0, ∞)
BandGroup	BandGroup: BandGroup1, BandGroup2, BandGroup3, BandGroup4, BandGroup5, BandGroup6	BandGroup1		enum	
DataRate	Data rate: _53.3 Mbps, _55 Mbps, _80 Mbps, _106.67 Mbps, _110 Mbps, _160 Mbps, _200 Mbps, _320 Mbps, _400 Mbps, _480 Mbps	_53.3 Mbps		enum	
DataLength	Octet number of	100		int	[1:4095]

Advanced Design System 2008

	PSDU				
PreambleFormat	PLCP preamble format: Standard Format, Burst Format	Standard Format		enum	
TFC_Number	Time frequency code: TFC1, TFC2, TFC3, TFC4, TFC5, TFC6, TFC7	TFC1		enum	
OversamplingOption	Oversampling ratio: Ratio 1, Ratio 2, Ratio 4, Ratio 8, Ratio 16, Ratio 32	Ratio 2		enum	
Bandwidth	Bandwidth	528 MHz	Hz	real	(0, ∞)
CyclicPrefix	Cyclic prefix with zero padding	70.08 nsec	sec	real	[0, ∞)
IdleInterval	Idle Interval	0.0 nsec	sec	real	[0, ∞)
ScramblerSeed	Scrambler seed selection: Seed 00, Seed 01, Seed 10, Seed 11	Seed 11		enum	
SearchMode	Searching mode synchronization: EveryFrame, Once	EveryFrame		enum	
SearchWindow	Searching window synchronization	24		int	†

†The minimum value of this parameter should be the number of OFDM symbols in the synchronization sequences portion of the PLCP preamble, and the maximum value of this parameter should be the number of OFDM symbols in one MB-OFDM frame.

Pin Inputs

Pin	Name	Description	Signal Type
1	RF_Signal	received RF signal to be demodulated	timed

Pin Outputs

Pin	Name	Description	Signal Type
2	For_EVM	undemapped signal after FFT used for EVM	complex
3	UnDecodedBits	deinterleaved data bits before decoding	int
4	PSDUFCS	PSDU bits with FCS	int
5	PSDU	PSDU bits	int

Notes/Equations

1. This subnetwork model implements UWB-OFDM RF receiver with frequency hopping function following [Reference 1](#). Firstly, the received RF signal with frequency hopping is demodulated by QAM_DemodExtOsc, then the demodulated signal is fed into baseband receiver. The RF receiver schematic is shown in the following figure.

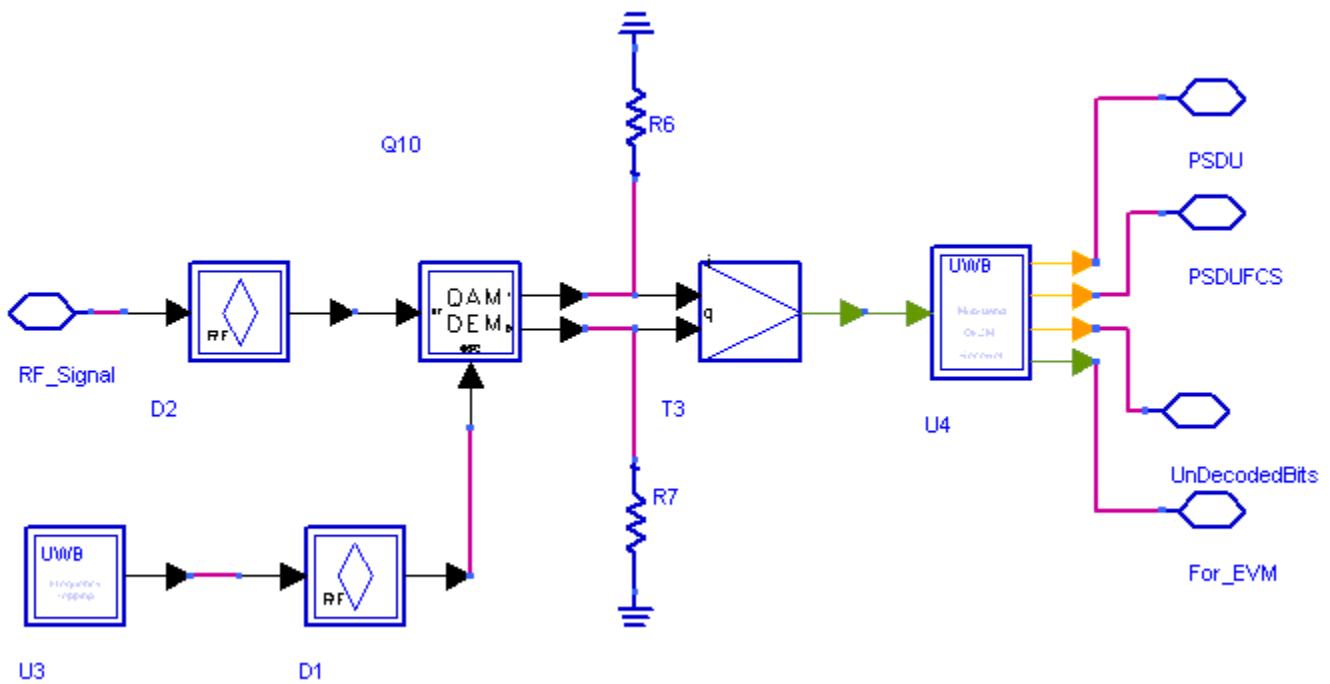

UWB_Receiver_FH_RF Schematic

References

1. "Multiband OFDM Physical Layer Specification", WiMedia Alliance document, Release 1.1, July 14, 2005.

UWB Receiver RF

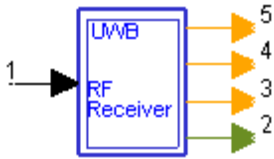

Description: UWB RF receiver
 Library: UWB, Receiver
 Class: TSDFUWB_Receiver_RF

Parameters

Name	Description	Default	Unit	Type	Range
RLoad	Input resistance	DefaultRLoad	Ohm	real	(0, ∞)
RTemp	Temperature	DefaultRTemp	Celsius	real	[-273.15, ∞)
FCarrier	Carrier frequency	3432MHz	Hz	real	(0, ∞)
GainImbalance	Gain imbalance, Q vs I	0.0	dB	real	(∞, ∞)
PhaseImbalance	Phase imbalance, Q vs I	0.0	deg	real	(∞, ∞)
Sensitivity	voltage output sensitivity, Vout/Vin	1		real	(∞, ∞)
Phase	Reference phase in degrees	0.0	deg	real	(∞, ∞)
BandGroup	BandGroup: BandGroup1, BandGroup2, BandGroup3, BandGroup4, BandGroup5, BandGroup6	BandGroup1		enum	
DataRate	Data rate: _53.3 Mbps, _55 Mbps, _80 Mbps,	_53.3 Mbps		enum	

Advanced Design System 2008

	_106.67 Mbps, _110 Mbps, _160 Mbps, _200 Mbps, _320 Mbps, _400 Mbps, _480 Mbps				
DataLength	Octet number of PSDU	100		int	[1:4095]
PreambleFormat	PLCP preamble format: Standard Format, Burst Format	Standard Format		enum	
TFC_Number	Time frequency code: TFC1, TFC2, TFC3, TFC4, TFC5, TFC6, TFC7	TFC1		enum	
OversamplingOption	Oversampling ratio: Ratio 1, Ratio 2, Ratio 4, Ratio 8, Ratio 16, Ratio 32	Ratio 2		enum	
Bandwidth	Bandwidth	528 MHz	Hz	real	(0, ∞)
CyclicPrefix	Cyclic prefix with zero padding	70.08 nsec	sec	real	[0, ∞)
IdleInterval	Idle Interval	0.0 nsec	sec	real	[0, ∞)
ScramblerSeed	Scrambler seed selection: Seed 00, Seed 01, Seed 10, Seed 11	Seed 11		enum	
FreqOffset	Actual frequency offset	0.0	Hz	real	(∞, ∞)
SearchMode	Searching mode synchronization: EveryFrame, Once	EveryFrame		enum	
SearchWindow	Searching window synchronization	24		int	†

†The minimum value of this parameter should be the number of OFDM symbols in the synchronization sequences portion of the PLCP preamble, and the maximum value of this parameter should be the number of OFDM symbols in one MB-OFDM frame.

Advanced Design System 2008

Pin Inputs

Pin	Name	Description	Signal Type
1	RF_Signal	received RF signal to be demodulated	timed

Pin Outputs

Pin	Name	Description	Signal Type
2	For_EVM	undemapped signal after FFT used for EVM	complex
3	UnDecodedBits	deinterleaved data bits before decoding	int
4	PSDUFCS	PSDU bits with FCS	int
5	PSDU	PSDU bits	int

Notes/Equations

1. This subnetwork is used to demodulate and decode single band UWB-OFDM RF signals without frequency hopping. The received RF signal is demodulated by QAM_Demod first and then the demodulated signal is fed into the baseband receiver for baseband processing. The RF receiver schematic is shown in the following figure.

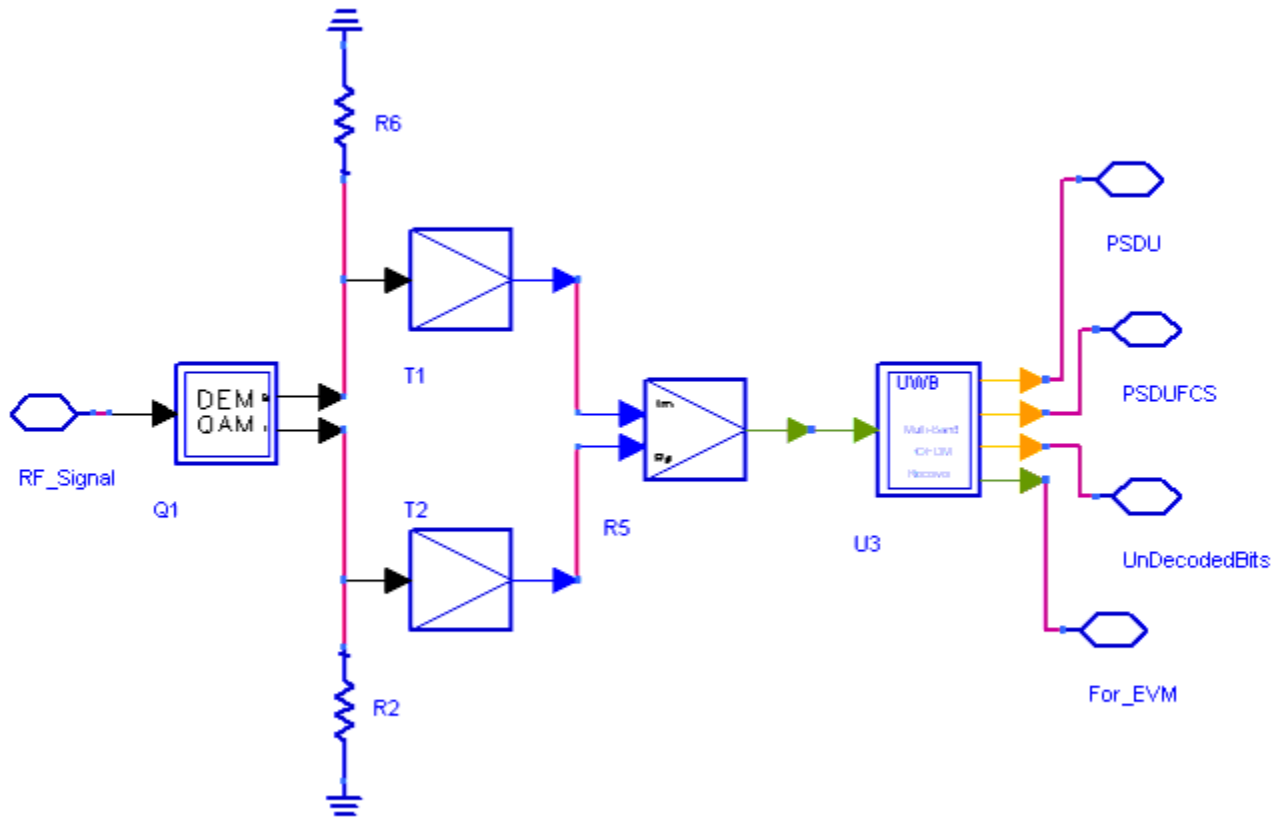

UWB_Receiver_RF Schematic

References

1. IEEE P802.15-04/0493r1, Multi-band OFDM Physical Layer Proposal for IEEE 802.15 Task Group 3a, September 2004.

Signal Source Components

UWB Freq Hopping



Description: UWB frequency hopping synthesizer

Library: UWB, Signal Source

Class: TSDFUWB_Freq_Hopping

Parameters

Name	Description	Default	Unit	Type	Range
ROut	Source resistance	DefaultROut	Ohm	real	(0, ∞)
RTemp	Temperature	DefaultRTemp	Celsius	real	[-273.15, ∞)
BandGroup	BandGroup: BandGroup1, BandGroup2, BandGroup3, BandGroup4, BandGroup5, BandGroup6	BandGroup1		enum	
DataRate	Data rate: _53.3 Mbps, _55 Mbps, _80 Mbps, _106.67 Mbps, _110 Mbps, _160 Mbps, _200 Mbps, _320 Mbps, _400 Mbps, _480 Mbps	_53.3 Mbps		enum	
DataLength	Octet number of PSDU	100		int	[1:4095]
PreambleFormat	PLCP preamble format: Standard Format, Burst Format	Standard Format		enum	
TFC_Number	Time frequency code: TFC1, TFC2, TFC3, TFC4, TFC5, TFC6, TFC7	TFC1		enum	
OversamplingOption	Oversampling	Ratio 2		enum	

Advanced Design System 2008

	ratio: Ratio 1, Ratio 2, Ratio 4, Ratio 8, Ratio 16, Ratio 32				
Bandwidth	Bandwidth	528 MHz	Hz	real	$(0, \infty)$
CyclicPrefix	Cyclic prefix with zero padding	70.08 nsec	sec	real	$[0, \infty)$
GuardInterval	Guard interval with zero padding	0.0 nsec	sec	real	$[0, \infty)$
IdleInterval	Idle Interval	0.0 nsec	sec	real	$[0, \infty)$
Fo	Oscillator frequency	4224e6	Hz	real	$(0, \infty)$
DeltaF	Oscillator frequency offset	0.0	Hz	real	(∞, ∞)

Pin Outputs

Pin	Name	Description	Signal Type
1	output	local Oscillator Out	timed

Notes/Equations

1. The subnetwork UWB_Freq_Hopping implements frequency hopping function in Band Group 1, The schematic of this subnetwork is shown in the following figure:

The time step per sample is:

$$T_{Step} = 1/(Bandwidth)/2^{OversamplingOption}$$

The duration time of one OFDM symbol is:

$$T_{SYM} = 128/(Bandwidth) + CyclicPrefix + GuardInterval$$

The subnetwork UWB_Freq_Hopping generates N samples with a fixed carrier frequency, then shifts to output N samples with another fixed carrier frequency. For example, according to the table of time frequency codes below, when TFC_Number=1, the subnetwork UWB_Freq_Hopping first generates N samples with 3432 MHz, then N samples with 3960 MHz, then N samples with 4488MHz periodically.

2. Frequency alloaction diagram is shown in the following diagram:

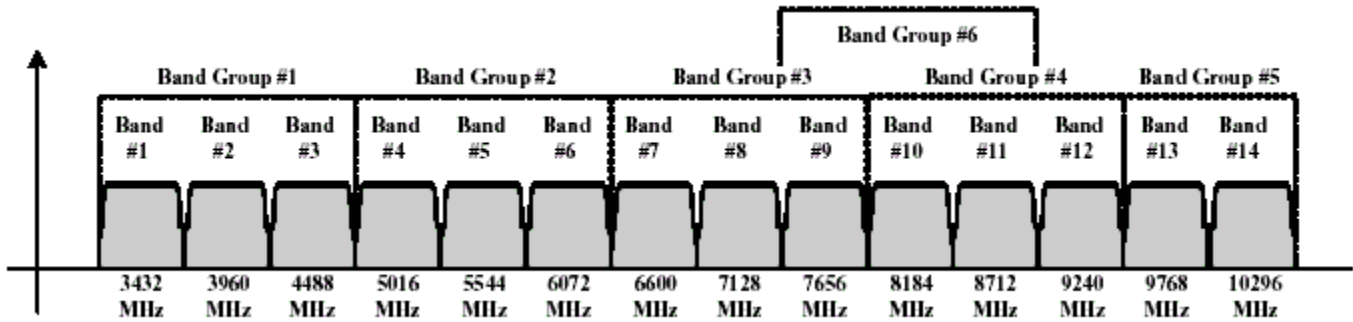

Frequency allocation diagram

Total six band groups are supported. For each band group, unique logical channels corresponding to different piconets are defined by using different time-frequency codes (TFCs). The TFCs and the preamble patterns associated with them are defined in the following table, using BAND_ID values for Band Group 1, and shall be defined in a similar manner for the Band Groups 2-6 by substituting the BAND_ID values appropriate for each Band Group. For example, for Band Group 2, the three BAND_ID values 4,5,6 shall replace the values 1,2,3 respectively in the table to generate the TFCs. For Band Groups 1-4, only TFCs numbered 1 through 4 shall be defined (with appropriate BAND_ID values). For Band Group 5, only TFC numbers 5 and 6 shall be defined (with appropriate BAND_ID values).

Time Frequency Codes and associated Preamble Patterns

TFC Number	Preamble Pattern number	Cover Sequence number	Length 6 Time Frequency Code (BAND ID values for Band Group 1)					
1	1	1	1	2	3	1	2	3
2	2	1	1	3	2	1	3	2

3	3	1	1	1	2	2	3	3
4	4	1	1	1	3	3	2	2
5	5	1	1	1	1	1	1	1
6	6	2	2	2	2	2	2	2
7	7	3	3	3	3	3	3	3

References

1. "Multiband OFDM Physical Layer Specification", WiMedia Alliance document, Release 1.1, July 14, 2005.

UWB Mapper

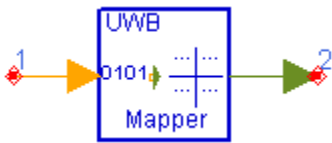

Description: UWB Constellation Mapper
 Library: UWB, Signal Source
 Class: SDFUWB_Mapper

Parameters

Name	Description	Default	Type
DataRate	Data rate: _53.3 Mbps, _55 Mbps, _80 Mbps, _106.67 Mbps, _110 Mbps, _160 Mbps, _200 Mbps, _320 Mbps, _400 Mbps, _480 Mbps	_53.3 Mbps	enum

Pin Inputs

Pin	Name	Description	Signal Type
1	Input	bit stream to be mapped onto constellation	int

Pin Outputs

Pin	Name	Description	Signal Type
2	Output	constellation mapped	complex

Notes/Equations

1. This model is used to map the channel coded and interleaved binary data sequence onto complex signals (constellations). For data rates 200Mb/s and lower, the binary data shall be mapped onto QPSK constellations. For data rates 320Mb/s and higher, the binary data shall be mapped onto multi-dimensional constellations using a dual-carrier modulation (DCM) technique.
2. Mapping are operated on OFDM symbols. Each firing, NCBPS (coded bits per OFDM symbol) bits are consumed at the Input pin, and ND (number of data sub-carriers in an OFDM symbol) complex constellations are generated at the Output pin, where

NCBPS=100, if data rate is equal to or less than 80 Mb/s;

NCBPS=200, if data rate is greater than 80Mb/s;

ND=100.

3. Assuming the input binary sequence are represented by $\{b[i]\}$, where $i=0, 1, 2, \dots, \text{NCBPS}$, and output constellations are represented by $\{d[k]\}$, where $k=0, 1, 2, \dots, \text{ND}$.

For data rates equal to or less than 80 Mb/s,

$$d[k] = K_{MOD} \times \{[(2 \times b[2k] - 1) + j(2 \times b[2k + 1] - 1)]\}, k = 0, 1, 2, \dots, 49 ;$$

$$d[k] = d^*[N_D - 1 - k], k = 50, 51, 52, \dots, N_D - 1 ;$$

$$K_{MOD} = \sqrt{1/2} .$$

For data rates equal to or less than 200Mb/s and greater than 80Mb/s,

$$d[k] = K_{MOD} \times \{[(2 \times b[2k] - 1) + j(2 \times b[2k + 1] - 1)]\}, k = 0, 1, 2, \dots, N_D - 1 ;$$

$$K_{MOD} = \sqrt{1/2} .$$

For data rates equal to or less than 480Mb/s and greater than 200Mb/s, $\{b[i]\}$ are divided into 50 group of 4 bits, each bit group is represented as $\{b[g(k)], b[g(k)+1], b[g(k)+50], b[g(k)+51]\}$, where $k=0, 1, 2, \dots, 49$ and

$$g[k] = \begin{cases} 2k & k \in [0, 24] \\ 2k + 50 & k \in [25, 49] \end{cases} .$$

$$d[k] = K_{MOD} \times \{b[g(k)] \cdot 4 - 2 + b[g(k) + 1] \cdot 2 - 1\} + jK_{MOD} \times \{b[g(k) + 50] \cdot 4 - 2 + b[g(k) + 51] \cdot 2 - 1\}, k \in [0, 49]$$

$$d[k + 50] = K_{MOD} \times \{b[g(k)] \cdot 2^{-1+2-(b[g(k)+1] \cdot 4)} + jK_{MOD} \times \{b[g(k) + 50] \cdot 2^{-1+2-(b[g(k) + 51] \cdot 4)}\}, k \in [0, 49]$$

$$K_{MOD} = \sqrt{1/10}$$

References

1. "Multiband OFDM Physical Layer Specification", WiMedia Alliance document, Release 1.1, July 14, 2005.

UWB PHY Header



Description: UWB physical header generator

Library: UWB, Signal Source

Class: SDFUWB_PHY_Header

Parameters

Name	Description	Default	Type	Range
BandGroup	BandGroup: BandGroup1, BandGroup2, BandGroup3, BandGroup4, BandGroup5, BandGroup6	BandGroup1	enum	
DataRate	Data rate: _53.3 Mbps, _55 Mbps, _80 Mbps, _106.67 Mbps, _110 Mbps, _160 Mbps, _200 Mbps, _320 Mbps, _400 Mbps, _480 Mbps	_53.3 Mbps	enum	
DataLength	Octet number of PSDU	100	int	[1:4095]
TFC_Number	Time frequency code: TFC1, TFC2, TFC3,	TFC1	enum	

Advanced Design System 2008

	TFC4, TFC5, TFC6, TFC7			
ScramblerSeed	Scrambler seed selection: Seed 00, Seed 01, Seed 10, Seed 11	Seed 00	enum	
BM_Bit	Whether the next packet transmission is in burst mode	1	int	[0:1]
PT_Bit	Type of PLCP preamble used in the next packet; 0 means Standard Preamble and 1 means Burst Preamble	0	int	[0:1]

Pin Outputs

Pin	Name	Description	Signal Type
1	DataOut	UWB PHY header data	int

Notes/Equations

1. This subnetwork is used to output the bits of PHY Header.
2. The schematic of this subnetwork is shown in the following figure:

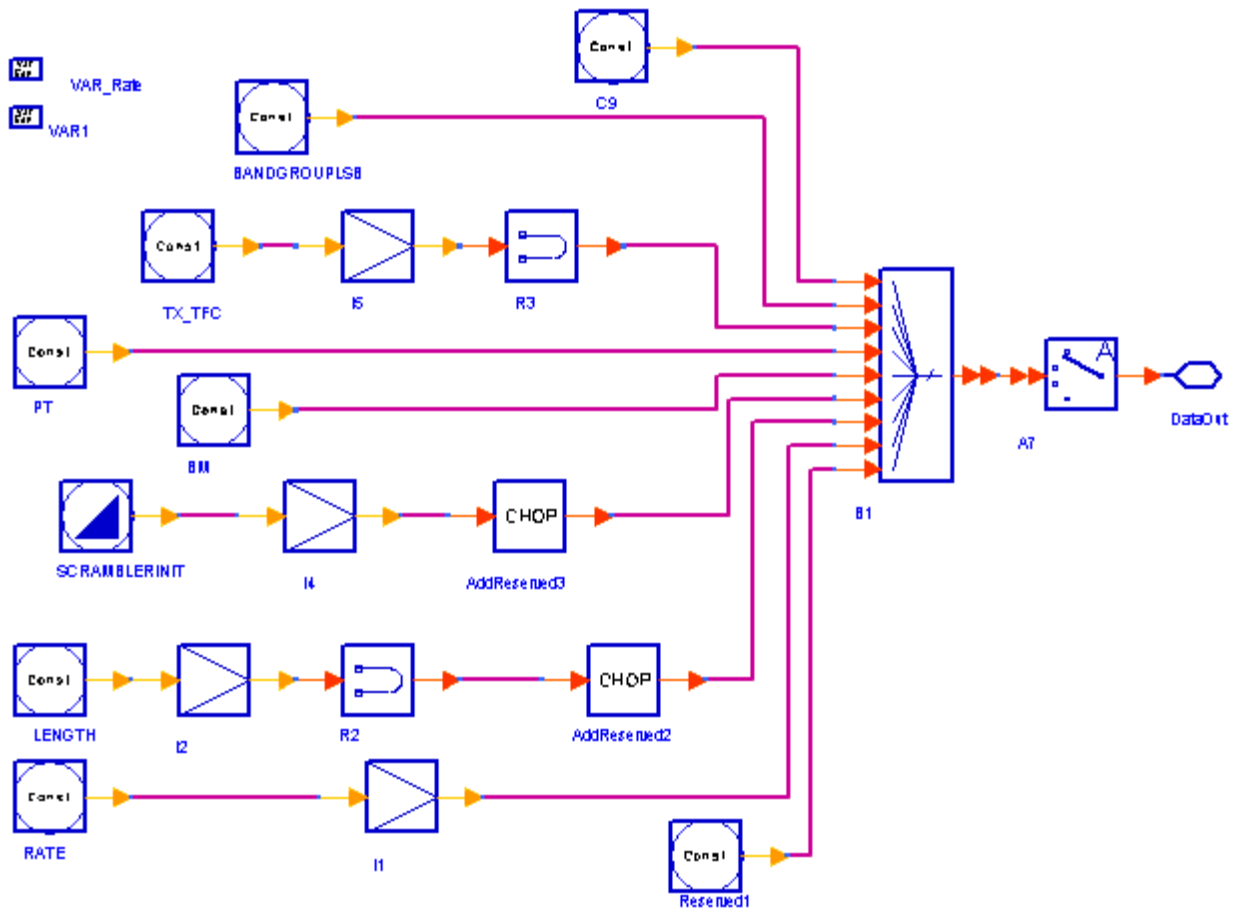

The schematic of subnetwork UWB_PHY_Header

3. The PHY header field shall be composed of 40 bits, as illustrated in the following figure. Bits 3-7 shall encode the RATE. Bits 8-19 shall encode the LENGTH field, with the least significant bit (LSB) being transmitted first. Bits 22-23 shall encode the seed value for the initial state of the scrambler, which is used to synchronize the descrambler of the receiver. Bit 26 shall encode whether the next packet is part of a packet "burst", i.e. burst mode transmission. Bit 27 shall encode the preamble type (standard or burst preamble) used in the next packet if in burst mode. Bits 28-30 shall be used to indicate the TF code used at the transmitter. Bit 31 shall be used to indicate the LSB of the band group used at the transmitter. All other bits which are not defined in this section shall be understood to be reserved for future use and shall be set to zero.

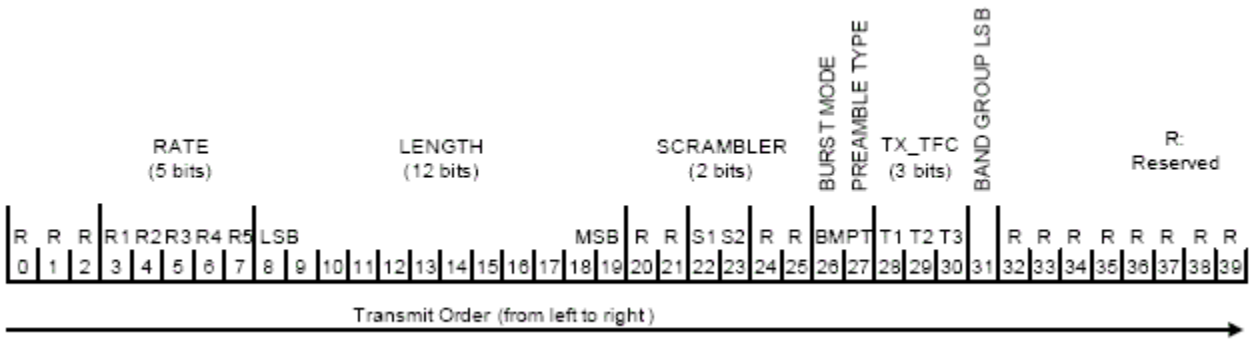

PHY Header bit assignment

4. The DataRate parameter is used to determine the RATE field. And the bits R1-R5 shall be set according to the values in the following table:

Rate (Mb/s)	R1 - R5
53.3	00000
80	00001
106.7	00010
160	00011
200	00100
320	00101
400	00110
480	00111
Reserved	01000-11111

- The DataLength parameter is used to determine the LENGTH field. The PLCP length field shall be an unsigned 12-bit integer that indicates the number of bytes in the frame payload (which does not include the FCS, the tail bits, or the pad bits).
- The ScramblerSeed parameter is used to determine the SCRAMBLER field. The MAC shall set bits S1-S2 according to the scrambler seed identifier value. This two-bit value corresponds to the seed value chosen for the data scrambler.
- The parameters BM_Bit and PT_Bit are used to determine the BM and PT fields. Because it is a MAC function to set BM and PT fields, user can set these two parameters according to section 6.3.1 of [1] if user want to test MAC layer function.
According to the specification, the MAC shall set the burst mode (BM) bit to indicate whether the next packet is part of a packet "burst", i.e. burst mode transmission. In this mode, the inter-frame spacing shall be equal to a pMIFSTime (see Section section 7.3 of [Reference 1](#)). In burst mode, the minimum packet size shall be 1 byte. In non-burst mode, the minimum packet size shall be zero bytes.

Burst mode bit (BM)	Next packet status
0	Next packet not part of burst
1	Next packet is part of burst

Advanced Design System 2008

The MAC shall set the preamble type (PT) bit in burst mode to indicate the type of PLCP preamble (standard or burst) used in the next packet as defined in the following table. For data rates of 200 Mbps and below, this bit shall be always set to zero.

Preamble Type bit (PT)	Type of preamble used in next packet
0	Standard Preamble
1	Burst Preamble

8. The TFC_Number parameter is used to determine TX_TFC field. The MAC shall configure the TX_TFC field to indicate the time-frequency code used at the transmitter for the current packet. Depending on the time-frequency code used, bits T1-T3 shall be set according to the values in the following table:

TF Code	T1 - T3
1	100
2	010
3	110
4	001
5	101
6	011
7	111
Reserved	000

9. The BandGroup parameter is used to determine BandGroup LSB (BG_LSB) field. The MAC shall configure the BG_LSB field to indicate the LSB of the band group used at the transmitter for the current packet. The bit BG_LSB shall be set according to the values in the following table:

Band Group	Band Group LSB (BG_LSB)
1,3,5	1
2,4	0

References

1. "Multiband OFDM Physical Layer Specification", WiMedia Alliance document, Release 1.1, July 14, 2005.

UWB_PLCP_Header



Description: UWB PLCP header generator

Library: UWB, Signal Source

Class: SDFUWB_PLCP_Header

Derived From: UWB_SubcktBase

Parameters

Name	Description	Default	Type	Range
BandGroup	BandGroup: BandGroup1, BandGroup2, BandGroup3, BandGroup4, BandGroup5, BandGroup6	BandGroup1	enum	
DataRate	Data rate: _53.3 Mbps, _55 Mbps, _80 Mbps, _106.67 Mbps, _110 Mbps, _160 Mbps, _200 Mbps, _320 Mbps, _400 Mbps, _480 Mbps	_53.3 Mbps	enum	
DataLength	Octet number of PSDU	100	int	[1, 4095]
TFC_Number	Time frequency code: TFC1, TFC2, TFC3, TFC4, TFC5, TFC6, TFC7	TFC1	enum	
ScramblerSeed	Scrambler seed selection: Seed 00, Seed 01, Seed 10, Seed 11	Seed 00	enum	
MAC_Header	10-byte MAC header	{0XD3, 0XC2, 0X36, 0X8C, 0X8F, 0X36, 0X0D, 0XBB, 0XED, 0XBA}	int array	(0, 255)
BM_Bit	Whether the next packet transmission is in burst mode	1	int	[0, 1]

PT_Bit	Type of PLCP preamble used in the next packet; 0 means Standard Preamble and 1 means Burst Preamble	0	int	[0, 1]
--------	---	---	-----	--------

Pin Outputs

Pin	Name	Description	Signal Type
1	DataOut	UWB PLCP header data	int

Notes/Equations

1. This subnetwork is used to output the bits of PLCP Header.
2. The schematic of this subnetwork is shown in the following figure:

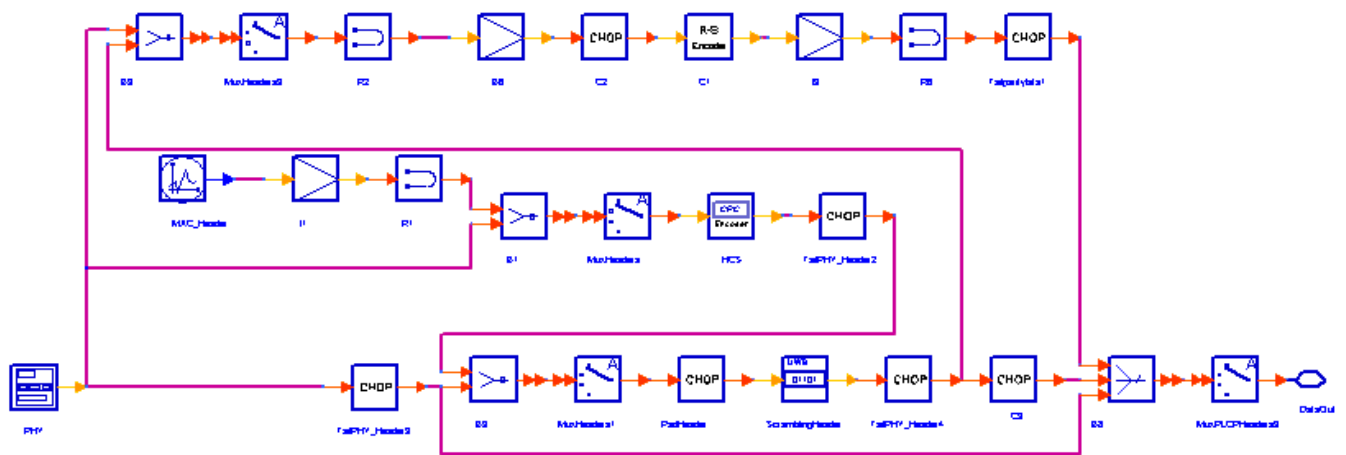

The schematic of subnetwork UWB_PLCP_Header

3. The PLCP header shall be composed of 200 bits to convey information about both the PHY and the MAC that is needed at the receiver in order to successfully decode the PSDU. The scrambled and Reed-Solomon encoded PLCP header shall be formed as shown in the following figure.

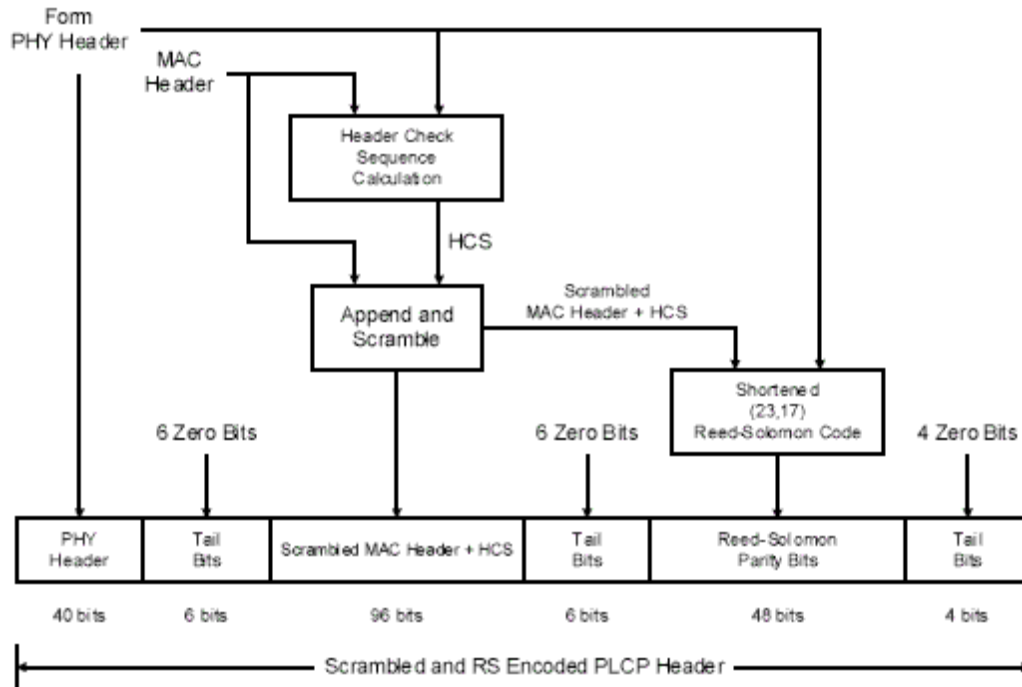

Block diagram of PLCP header construction

- Format the PHY header based on information provided by the MAC.
 - Calculate the HCS value (2 octets) over the combined PHY and MAC headers.
 - The resulting HCS value is appended to the MAC header. The resulting combination (MAC Header + HCS) is scrambled.
 - Apply a shortened Reed-Solomon code (23, 17) to the concatenation of the PHY header (5 octets), scrambled MAC header and HCS (12 octets).
 - Insert 6 tail bits after the PHY header, 6 tail bits after the scrambled MAC header and HCS, and append the 6 parity octets and 4 tail bits at the end to form the scrambled and Reed-Solomon encoded PLCP header. The output bits of PLCP header is encoded using a R=1/3, K=7 convolutional code, interleaved using a bit interleaver, mapped onto a QPSK constellation and finally, the resulting complex values are loaded onto the data subcarriers for the IDFT in order to create the real baseband signal.
4. The PHY header contains information about the data rate of the MAC frame body, the length of the frame payload (which does not include the FCS), the seed identifier for the data scrambler, and information about the next packet - whether it is being sent in burst mode and whether it employs a burst preamble or not.
5. The combination of PHY header and the MAC header shall be protected with a 2 bytes CCITT CRC-16 header check sequence (HCS). The CCITT CRC-16 HCS shall be the ones complement of the remainder generated by the modulo-2 division of the combined PHY and MAC headers by the polynomial: $x^{16} + x^{12} + x^5 + 1$. The HCS bits shall be processed in the transmit order. All HCS calculations shall be made prior to data scrambling. The schematic of the processing order is shown in the following figure. The registers shall be initialized to all ones.

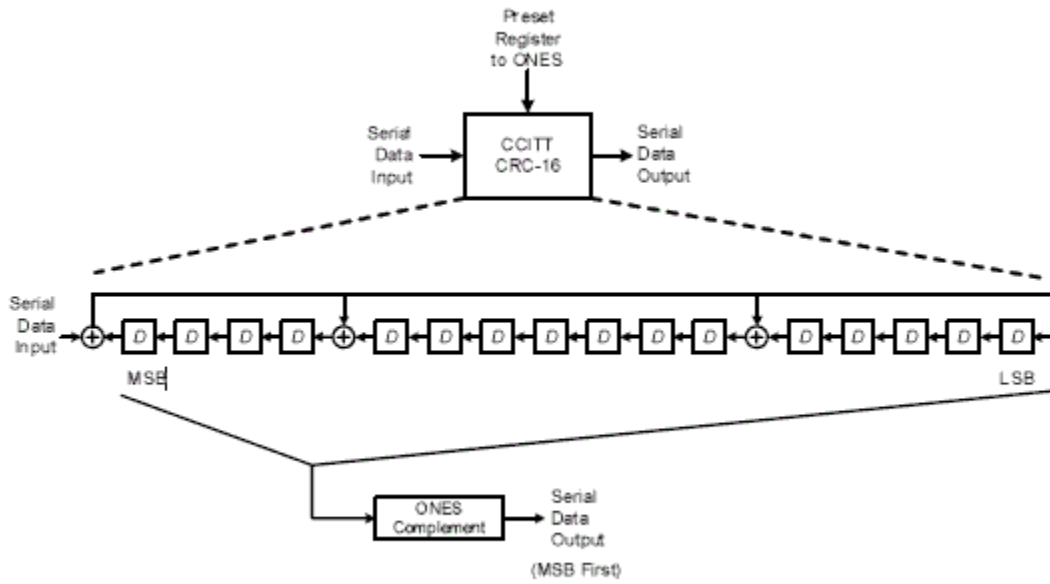

CCITT CRC-16 block diagram

6. The MAC header and HCS shall be scrambled. The scrambler shall be initialized to a seed value specified by the MAC at the beginning of the MAC header and then re-initialized to the same seed value at the beginning of the PSDU.

The polynomial generator, $g(D)$, for pseudo-random binary sequence (PRBS) used to scramble the MAC header and HCS bits shall be:

$$g(D) = 1 + D^{14} + D^{15}$$

where D is a single bit delay element. Using this generator, the corresponding PRBS, x_n is generated as $x_n = x_{n-14} \oplus x_{n-15}$, $n=0,1,2,\dots$

The following sequence defines the initialization vector, x_{init} , which is specified by the parameter "seed value" in the following table.

$$x_{init} = [x_{n-1}^i x_{n-1}^i \dots x_{n-14}^i x_{n-15}^i]$$

where x_{n-k}^i represents the binary initial value at the output of the k th delay element.

Seed identifier (S 1 , S 2)	Seed value (x -1 x -2 ...x -14 x -15)	Scrambler Output First 16 bits x 0 x 1 ...x 15
0,0	0011 1111 1111 111	0000000000001000
0,1	0111 1111 1111 111	0000000000000100
1,0	1011 1111 1111 111	0000000000001110
1,1	1111 1111 1111 111	0000000000000010

The output scrambled data bits, s_m , are obtained as follows:

$$s_m = d_m \oplus x_m, m=0,1,2,\dots$$

where d_m represents the unscrambled MAC header and HCS bits.

7. The PLCP header shall use a systematic (23, 17) Reed-Solomon outer code to improve upon the robustness of

the R=1/3, K=7 inner convolutional code. The Reed-Solomon code is defined over $GF(2^8)$ with a primitive polynomial $p(z) = z^8 + z^4 + z^3 + z^2 + 1$, where α is the root of the primitive polynomial $p(z)$. For

brevity, this Galois field is denoted as F. As notation, the element

$M = b_7z^7 + b_6z^6 + b_5z^5 + b_4z^4 + b_3z^3 + b_2z^2 + b_1z^1 + b_0$, where $M \in F$, has the following binary representation $b_7b_6b_5b_4b_3b_2b_1b_0$, where b_7 is the MSB and b_0 is the LSB.

The generator polynomial is obtained by shortening a systematic (255,249) Reed-Solomon code, which is specified by the generator polynomial:

$$g(x) = \prod_{i=1}^6 (x - \alpha^i) = x^6 + 126x^5 + 4x^4 + 158x^3 + 58x^2 + 49x + 117$$

, where $g(x)$ is the generator

polynomial over F, $x \in F$ and the coefficients are given in decimal notation.

The mapping of the information bytes $m = (m_{248}, m_{247}, \dots, m_0)$ to codeword bytes

$$c = (m_{248}, m_{247}, \dots, m_0, r_5, r_4, \dots, r_0)$$

is achieved by computing the remainder polynomial $r(x)$,

$$r(x) = \prod_{i=0}^5 r_i x^i = x^6 m(x) \text{ mod } g(x)$$

, where $m(x)$ is the information polynomial:

248 , and $r_i, i=0, \dots, 5$, and $m_i, i=0, \dots, 248$, are elements of F.

$$m(x) = \prod_{i=0}^{248} m_i x^i$$

The shortening operation pre-appends 232 zero elements to the incoming 17 octets message as follow: $m_i = 0, i=17, \dots, 248$, where the 17 bytes message is formed by concatenating the 5 bytes PHY header and the 12 bytes scrambled MAC header and HCS. The message order is as follows: m_{16} is the first octet of the PHY header, m_{12} is the last byte of the PHY header, m_{11} is the first byte of the scrambled MAC header and HCS and m_0 is the last one. The bit mapping within the PLCP header is LSB first. The order of parity bytes is as follow: r_5 is the first and r_0 is the last octet of the Reed-Solomon parity section. The mapping within the Reed-Solomon parity section of the PLCP header is LSB first.

References

1. "Multiband OFDM Physical Layer Specification", WiMedia Alliance document, Release 1.1, July 14, 2005.

UWB SignalSource

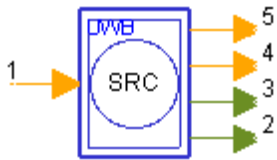

Description: UWB signal source
 Library: UWB, Signal Source
 Class: SDFUWB_SignalSource

Parameters

Name	Description	Default	Unit	Type	Range
BandGroup	BandGroup: BandGroup1, BandGroup2, BandGroup3, BandGroup4, BandGroup5, BandGroup6	BandGroup1		enum	
DataRate	Data rate: _53.3 Mbps, _55 Mbps, _80 Mbps, _106.67 Mbps, _110 Mbps, _160 Mbps, _200 Mbps, _320 Mbps, _400 Mbps, _480 Mbps	_53.3 Mbps		enum	
DataLength	Octet number of PSDU	100		int	[1:4095]
PreambleFormat	PLCP preamble format: Standard Format, Burst Format	Standard Format		enum	
TFC_Number	Time frequency code: TFC1, TFC2, TFC3, TFC4, TFC5, TFC6, TFC7	TFC1		enum	
OversamplingOption	Oversampling ratio: Ratio 1, Ratio 2, Ratio 4,	Ratio 2		enum	

Advanced Design System 2008

	Ratio 8, Ratio 16, Ratio 32				
Bandwidth	Bandwidth	528 MHz	Hz	real	(0, ∞)
CyclicPrefix	Cyclic prefix with zero padding	70.08 nsec	sec	real	[0, ∞)
IdleInterval	Idle Interval	0.0 nsec	sec	real	[0, ∞)
ScramblerSeed	Scrambler seed selection: Seed 00, Seed 01, Seed 10, Seed 11	Seed 00		enum	
MAC_Header	10-byte MAC header	{0XD3, 0XC2, 0X36, 0X8C, 0X8F, 0X36, 0X0D, 0XBB, 0XED, 0XBA}		int array	(0:255)

Pin Inputs

Pin	Name	Description	Signal Type
1	PSDU	Physical Service Data Unit bits	int

Pin Outputs

Pin	Name	Description	Signal Type
2	Signal	baseband signal	complex
3	ForEVM	signal for EVM test	complex
4	Encoded	encoded PSDU	int
5	PSDUFCS	PSDU bits with FCS added	int

Notes/Equations

1. This subnetwork is used to generate baseband signal for UWB. The schematic of this subnetwork is shown in the following figure.

320	DCM	1/2	No	No	1200	600
400	DCM	5/8	No	No	1200	750
480	DCM	3/4	No	No	1200	900

* denotes the data rate which the new specification is not defined

- CyclicPrefix, IdleInterval are used to set the timing-related parameters. CyclicPrefix is part of zero pad duration after the IFFT output. IdleInterval is used to simulate the arbitrary time interval between two UWB packets.
- OverSamplingOption and Bandwidth are used to set the TStep of simulation.
- The format of preamble can also be set by parameter PreambleFormat.
- The time frequency code is decided by the parameter TFC_Number.
- MAC_Header is used to specify the content of MAC header.

4. UWB_SignalSource is implemented according to the specifications in [Reference 1](#). The following figure shows the format for the PLCP frame including three parts: the PLCP preamble, PLCP header (PHY header, MAC header, header check sequence, tail bits, Reed-Solomon parity bits and tail bits), MAC frame body (frame payload plus FCS, tail bits, and pad bits).

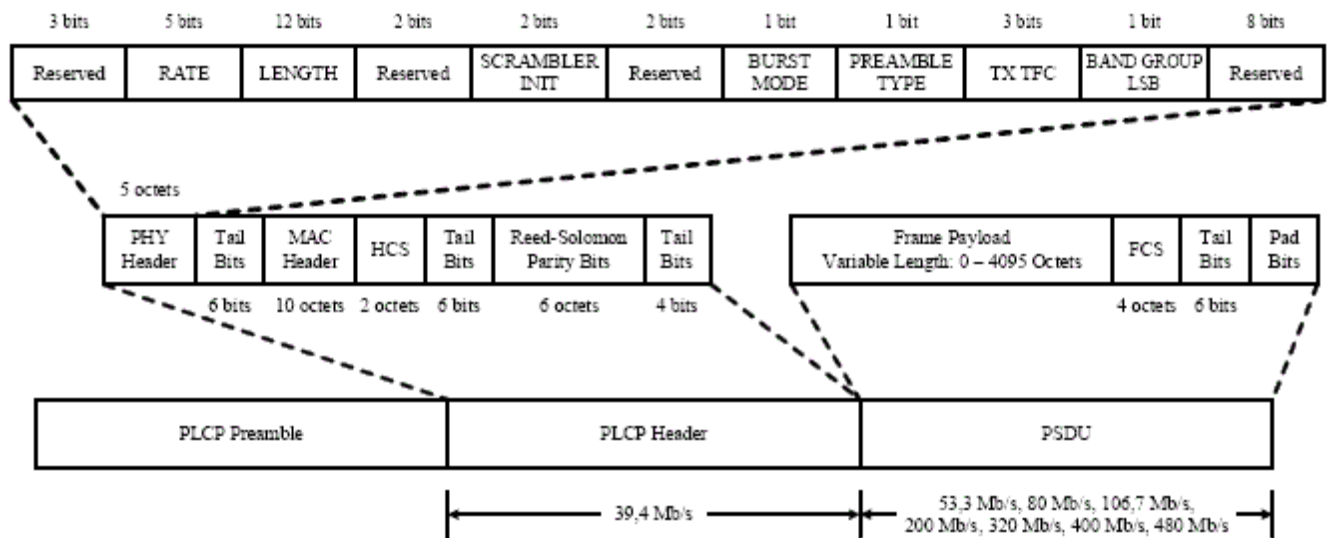

PLCP frame format.

The standard PLCP preamble consists of two portions: the packet/frame synchronization sequence and the channel estimation sequence. There are 24 or 12 OFDM symbols in the time domain synchronization sequence portion for Standard preamble or Burst preamble, respectively and 6 OFDM symbols in the channel estimation sequence. These two portions are implemented by the model WaveFormCx. The FFT and IFFT are used to oversample the basic timed domain sequence. The the packet/frame synchronization sequence and the channel estimation sequence are repeated, multiplied by the cover sequence and then combined to the preamble. The PLCP header bits is produced by the model PLCP_Header, which consists of 200 bits. The output bits of PLCP_Header is encoded using a R=1/3, K=7 convolutional code, interleaved using a bit interleaver, mapped onto a QPSK constellation and finally, the resulting complex values are loaded onto the data subcarriers for the

IDFT in order to create the real baseband signal.

The PSDU data part is appended the frame check sequence after frame body by the model UWB_FCS, scrambled by UWB_Scrambler, added pad bits, coded, punctured, interleaved and mapped. Then the UWB_MuxOFDMSym model is used to map the input data, generated pilot and guard into their corresponding subcarriers.

The PLCP header and the PSDU data is multiplexed by the model UWB_MuxHeadPSDU. Then the model UWB_TimeSpreading performs the time-domain spreading for the multiplexed PLCP header and PSDU data. After this the IFFT is executed to produce the time-domain signal.

The model UWB_MuxFrame is used to multiplex the PLCP preamble and the multiplexed PLCP header and PSDU data symbols into one frame.

The number of OFDM symbols per UWB-OFDM frame also consists of three parts.

There is 30 and 18 OFDM symbols for Standard preamble and Burst preamble, respectively.

$$N_{sym}Preamble = \begin{cases} 30 & \text{Standard} \\ 18 & \text{Shortened} \end{cases}$$

The OFDM symbols of PLCP Header after time-domain spreading is as follows: $N_{sym}Header = 12$

MAC frame body consists of frame payload, FCS, tail bits, and pad bits. The OFDM symbols of PSDU after time-domain spreading is computed as follows:

$$N_{sym}PSDU = 6 \times \left\lceil \frac{8 \times DataLength + 38}{N_{IBP6S}} \right\rceil$$

Where N_{IBP6S} are determined by the data rate. Please refer to the preceding table for details.

The number of pad bits is:

$$N_{pad} = N_{IBP6S} \times \left\lceil \frac{8 \times DataLength + 38}{N_{IBP6S}} \right\rceil - (8 \times DataLength + 38)$$

So, the total number of OFDM symbols N_{SYM}

per UWB-OFDM frame is: $N_{SYM} = N_{sym}Preamble + N_{sym}Header + N_{sym}PSDU$

References

1. "Multiband OFDM Physical Layer Specification", WiMedia Alliance document, Release 1.1, July 14, 2005.

UWB SignalSource RF

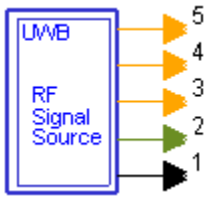

Description: UWB RF signal source
 Library: UWB, Signal Source
 Class: TSDFUWB_SignalSource_RF

Parameters

Name	Description	Default	Unit	Type	Range
ROut	Source resistance	DefaultROut	Ohm	real	(0, ∞)
RTemp	Temperature	DefaultRTemp	Celsius	real	[-273.15, ∞)
TStep	Expression showing how TStep is related to the other source parameters	1/Bandwidth/(2^OversamplingOption)		string	
FCarrier	Carrier frequency	3432MHz	Hz	real	(0, ∞)
Power	Power	0.01	W	real	[0, ∞)
MirrorSpectrum	Mirror spectrum about carrier?: NO, YES	NO		enum	
GainImbalance	Gain imbalance, Q vs I	0.0	dB	real	(∞, ∞)
PhaseImbalance	Phase imbalance, Q vs I	0.0	deg	real	(∞, ∞)
I_OriginOffset	I origin offset (percent)	0.0		real	(∞, ∞)
Q_OriginOffset	Q origin offset (percent)	0.0		real	(∞, ∞)
IQ_Rotation	IQ rotation	0.0	deg	real	(∞, ∞)
DataPattern	Data pattern: PN9, PN15, FIX4, _4_1_4_0, _8_1_8_0, _16_1_16_0, _32_1_32_0, _64_1_64_0	PN9		enum	

Advanced Design System 2008

BandGroup	BandGroup: BandGroup1, BandGroup2, BandGroup3, BandGroup4, BandGroup5, BandGroup6	BandGroup1		enum	
DataRate	Data rate: _53.3 Mbps, _55 Mbps, _80 Mbps, _106.67 Mbps, _110 Mbps, _160 Mbps, _200 Mbps, _320 Mbps, _400 Mbps, _480 Mbps	_53.3 Mbps		enum	
DataLength	Octet number of PSDU	100		int	[1:4095]
PreambleFormat	PLCP preamble format: Standard Format, Burst Format	Standard Format		enum	
TFC_Number	Time frequency code: TFC1, TFC2, TFC3, TFC4, TFC5, TFC6, TFC7	TFC1		enum	
OversamplingOption	Oversampling ratio: Ratio 1, Ratio 2, Ratio 4, Ratio 8, Ratio 16, Ratio 32	Ratio 2		enum	
Bandwidth	Bandwidth	528 MHz	Hz	real	(0, ∞)
CyclicPrefix	Cyclic prefix with zero padding	70.08 nsec	sec	real	[0, ∞)
IdleInterval	Idle Interval	0.0 nsec	sec	real	[0, ∞)
ScramblerSeed	Scrambler seed selection: Seed 00, Seed 01, Seed 10, Seed 11	Seed 00		enum	
MAC_Header	10-byte MAC header	{0XD3, 0XC2, 0X36, 0X8C, 0X8F, 0X36, 0X0D, 0XBB,		int array	(0:255)

		0XED, 0XBA}		
--	--	-------------	--	--

Pin Outputs

Pin	Name	Description	Signal Type
1	RF	RF signal	timed
2	For_EVM	signal for EVM test	complex
3	EncodedBits	encoded PSDU	int
4	PSDUFCS	PSDU bits with FCS added	int
5	PSDU	PSDU bits	int

Notes/Equations

1. This subnetwork is used to generate RF signal of UWB system.
2. The schematic of this subnetwork is shown in the following figure:

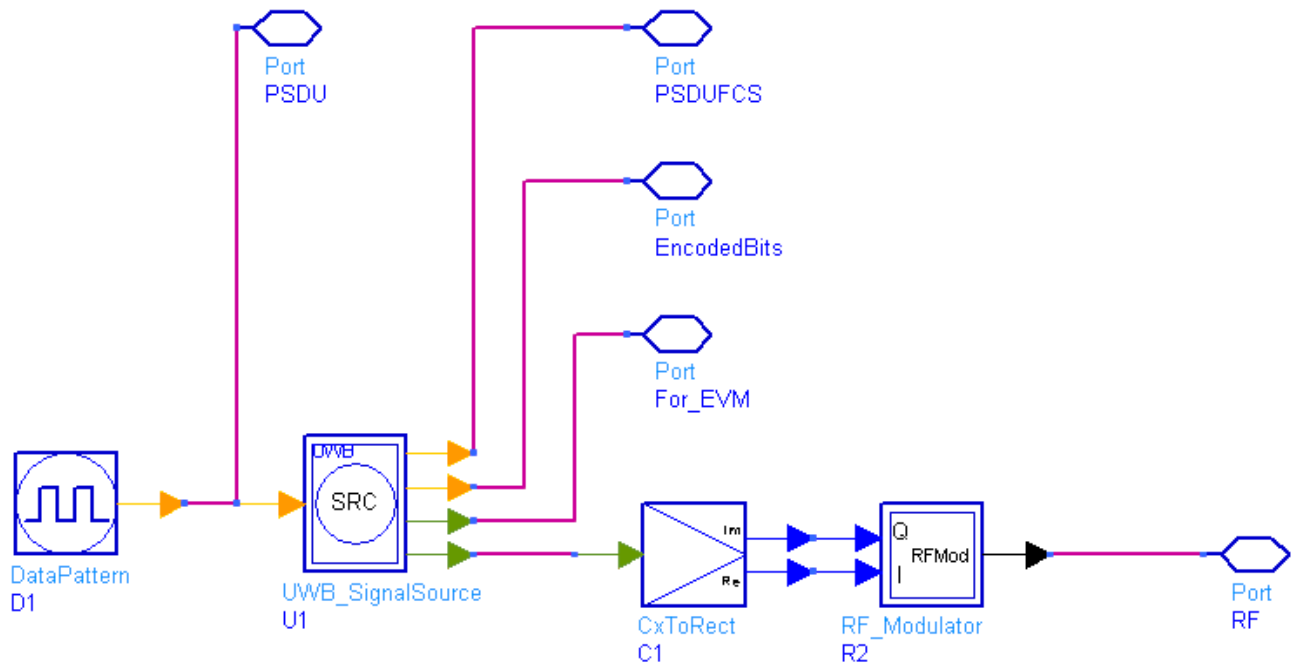

The schematic of subnetwork UWB_SignalSource_RF

According to the schematic, the subnetwork includes two parts. One is UWB_SignalSource, which generates the baseband signal of UWB system. Another part is RF_Modulator.

3. The signal source can be easily user-defined by changing the setting of parameter list above.
- ROut, RTemp, Power, GainImbalance, PhaseImbalance are used to set the RF features of UWB system.
 - BandGroup is used to set the band group used at the transmitter for the current packet.
 - DataRate, DataLength, ScramblerSeed are used to set the multi-band OFDM PHY specific service parameter. These parameters will be transmitted in the PHY header and also be used to frame the packets. When the DataRate is set, the data rate-dependent parameters such as modulation, coding rate, frequency spreading factor, time spreading factor, and information bits per 6 OFDM symbol (N IBP6S) will be set according to the specification. Please refer to the following table for detail.
{anchor:1173015

rate-dependent parameters

Data Rate (Mb/s)	Modulation	Coding rate (R)	Frequency-Domain Spreading (FDS)	Time-Domain Spreading (TDS)	Coded bits / 6 OFDM symbol (NCBP6S)	Info bits / 6 OFDM symbol (NIBP6S)
53.3	QPSK	1/3	Yes	Yes	300	100
55*	QPSK	11/32	Yes	Yes	300	103.125
80	QPSK	1/2	Yes	Yes	300	150
106.7	QPSK	1/3	No	Yes	600	200
110*	QPSK	11/32	No	Yes	600	206.25
160	QPSK	1/2	No	Yes	600	300
200	QPSK	5/8	No	Yes	600	375
320	DCM	1/2	No	No	1200	600
400	DCM	5/8	No	No	1200	750
480	DCM	3/4	No	No	1200	900
* denotes the data rate which the new specification is not defined						

- CyclicPrefix, IdleInterval are used to set the timing-related parameters. CyclicPrefix is part of zero pad duration after the IFFT output.
IdleInterval is used to simulate the arbitrary time interval between two UWB packets.
- OverSamplingOption and Bandwidth are used to set the TStep of simulation.
- The format of preamble can also be set by parameter PreambleFormat.
- The time frequency code is decided by the parameter TFC_Number.
- MAC_Header is used to specify the content of MAC header.

References

1. "Multiband OFDM Physical Layer Specification", WiMedia Alliance document, Release 1.1, July 14, 2005.

UWB Source FH RF

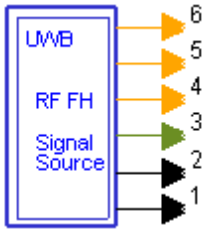

Description: UWB RF frequency hopping signal source

Library: UWB, Signal Source

Class: TSDFUWB_Source_FH_RF

Parameters

Name	Description	Default	Unit	Type	Range
ROut	Source resistance	DefaultROut	Ohm	real	(0, ∞)
RTemp	Temperature	DefaultRTemp	Celsius	real	[-273.15, ∞)
TStep	Expression showing how TStep is related to the other source parameters	$1/\text{Bandwidth}/(2^{\text{OversamplingOption}})$		string	
Power	Power	0.01	W	real	[0, ∞)
GainImbalance	Gain imbalance, Q vs I	0.0	dB	real	(∞, ∞)
PhaseImbalance	Phase imbalance, Q vs I	0.0	deg	real	(∞, ∞)
DataPattern	Data pattern: PN9, PN15, FIX4, _4_1_4_0, _8_1_8_0, _16_1_16_0, _32_1_32_0, _64_1_64_0	PN9		enum	
BandGroup	BandGroup: BandGroup1, BandGroup2, BandGroup3, BandGroup4, BandGroup5, BandGroup6	BandGroup1		enum	

Advanced Design System 2008

DataRate	Data rate: _53.3 Mbps, _55 Mbps, _80 Mbps, _106.67 Mbps, _110 Mbps, _160 Mbps, _200 Mbps, _320 Mbps, _400 Mbps, _480 Mbps	_53.3 Mbps		enum	
DataLength	Octet number of PSDU	100		int	[1:4095]
PreambleFormat	PLCP preamble format: Standard Format, Burst Format	Standard Format		enum	
TFC_Number	Time frequency code: TFC1, TFC2, TFC3, TFC4, TFC5, TFC6, TFC7	TFC1		enum	
OversamplingOption	Oversampling ratio: Ratio 1, Ratio 2, Ratio 4, Ratio 8, Ratio 16, Ratio 32	Ratio 2		enum	
Bandwidth	Bandwidth	528 MHz	Hz	real	(0, ∞)
CyclicPrefix	Cyclic prefix with zero padding	70.08 nsec	sec	real	[0, ∞)
IdleInterval	Idle Interval	0.0 nsec	sec	real	[0, ∞)
ScramblerSeed	Scrambler seed selection: Seed 00, Seed 01, Seed 10, Seed 11	Seed 00		enum	
MAC_Header	10-byte MAC header	{0XD3, 0XC2, 0X36, 0X8C, 0X8F, 0X36, 0X0D, 0XBB, 0XED, 0XBA}		int array	(0:255)

Pin Outputs

Pin	Name	Description	Signal Type
1	RF	RF signal	timed

2	RFCarrier	hopping carrier	timed
3	For_EVM	signal for EVM test	complex
4	EncodedBits	encoded PSDU	int
5	PSDUFCS	PSDU bits with FCS added	int
6	PSDU	PSDU bits	int

Notes/Equations

1. This subnetwork is used to generate RF signal for UWB with frequency hopping. The schematic of this subnetwork is shown in the following figure.

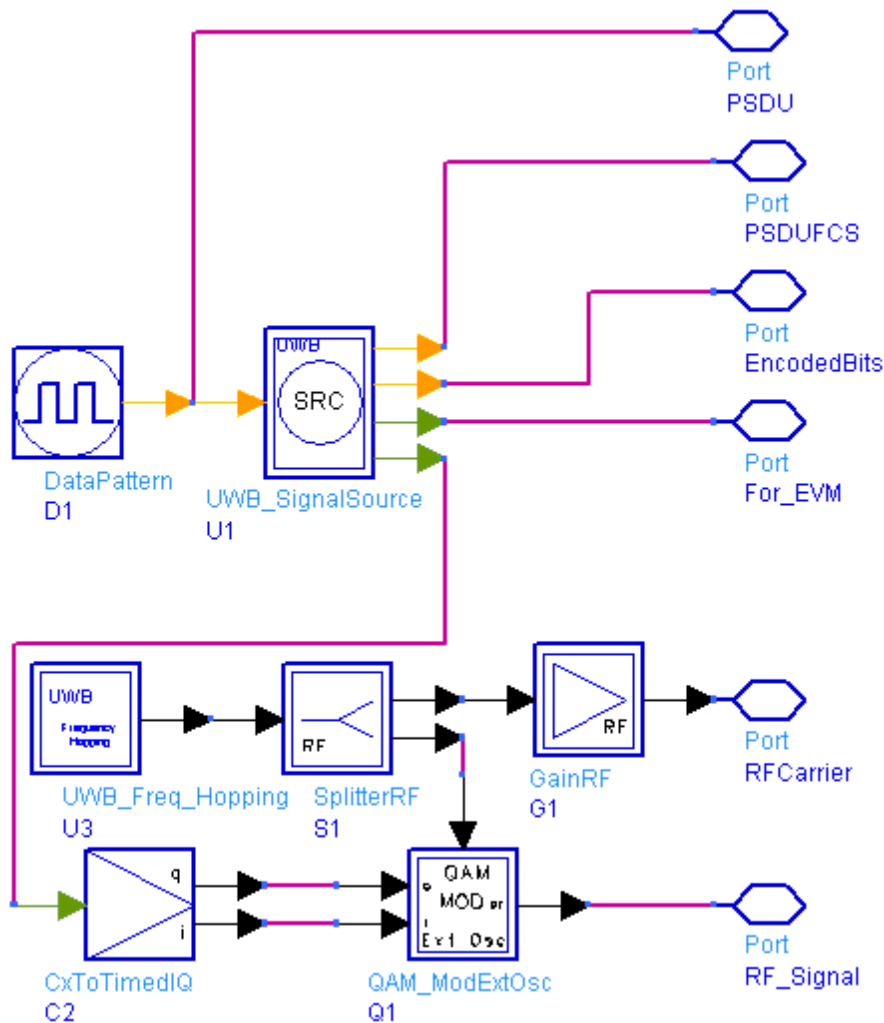

The schematic of subnetwork UWB_Souce_FH_RF

According to the schematic, the subnetwork includes two parts. One is UWB_SignalSource, which generates the baseband signal of UWB system. Another part is QAM_ModExtOsc, which implements multi-band OFDM RF system. The UWB_Freq_Hopping can support all the frequency pattern of all Band Group. DataPattern is used to simulate the data for P SDU.

2. The detailed information about baseband signal generator can be found in online manual of UWB_SignalSource.
3. ROut, RTemp, Power, GainImbalance, PhaseImbalance are used to set the RF features of UWB system.
4. The time-frequency code number can be set by parameter TFC_Number. The TFC_Number also defines the preamble pattern number and cover sequence number in UWB system. For BandGroup1, 2, 3 and 4, the valid value for TFC_Number is 1, 2, 3, 4, 5, 6 and 7. For BandGroup 5, only TFC_Number 5 and 6 is defined.
5. The hopping carriers are generated by UWB_Freq_Hopping. Note that the FCarrier here can not be changed in one simulation. Please refer to the on-line manual of UWB_Freq_Hopping for detailed information.
6. The model G1 is used to set the output impedance of RFCarrier.

References

1. "Multiband OFDM Physical Layer Specification", WiMedia Alliance document, Release 1.1, July 14, 2005.

UWB Receiver Test & Verification Design Examples

Introduction

The UWB_OFDM_Rx_prj provides UWB receiver test and measurement design examples, which are built up based on WiMedia Multiband OFDM Physical Layer Specification, release 1.1:

- UWB_OFDM_RxSensitivity.dsn: minimum receiver sensitivity measurement
- UWB_OFDM_PER_vs_Range_AWGN.dsn: PER performance under AWGN channel
- UWB_OFDM_PER_vs_Range_Fading.dsn: PER performance under fading channel
- UWB_OFDM_ADC_Effect.dsn: Receiver performance with ADC effect
- UWB_OFDM_Rx_with_WLAN_11a_Interferer.dsn: Receiver performance with WLAN 11a Interferer
- UWB_OFDM_Rx_with_WiMax_Interferer.dsn: Receiver performance with WiMax Interferer

UWB MB-OFDM Receiver Minimum Input Level Sensitivity Measurement:

UWB_OFDM_RxSensitivity.dsn

Features

- data rate is 200 Mbps
- NF is 6.6 dB

Description

This design is an example of UWB MB-OFDM receiver minimum input level sensitivity measurement. According to the section 1.6 of [Reference 1](#), for a packet error rate (PER) shall be less than 8% at a PSDU length of 1024 bytes, the minimum receiver sensitivity numbers for the various rates and modes are listed in the following table. The minimum input levels are measured at the antenna connector (NF is assumed to be 6.6 dB). For data rate of 200 Mbps, the sensitivity number is -74.5 dBm.

The schematic of this design is shown in the following figure. The flexible parameters that users have access to are listed in `Signal_Generation_VARS', `RF_Channel_VAR' and `Measurement_VAR'.

UWB_OFDM_RxSensitivity.dsn



Push into Info to read local information

UWB OFDM: Receiver minimum input level sensitivity measurement for MB-OFDM

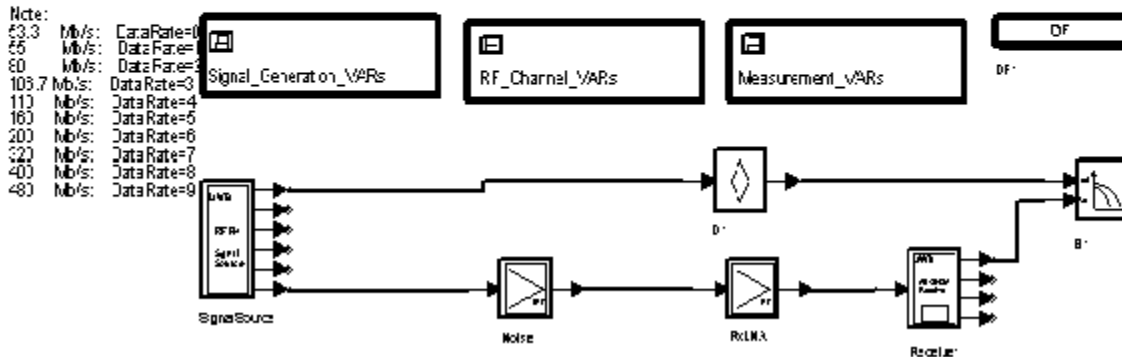

UWB_OFDM_RxSensitivity.dsn

Specification requirements

Advanced Design System 2008

Data Rate (Mbps)	Minimum sensitivity (dBm) for Mode 1
53.3	-80.8
80	-78.9
106.7	-77.8
160	-75.9
200	-74.5
320	-72.8
400	-71.5
480	-70.4

Simulation Results

Simulation results are displayed in UWB_OFDM_RxSensitivity.dds. BER and PER at given input levels are simulated. This page is shown in the following figure.

Index	BER	PER
0	0.000	0.000

Eqn PER=FER

UWB_OFDM_RxSensitivity.dds

Benchmark

- Hardware Platform: Pentium-M 2GHz, 1.5GB memory
- Software Platform: Windows XP, ADS 2005A
- Simulation Time: approximately 2 hours

1. "Multiband OFDM Physical Layer Specification", WiMedia Alliance document, Release 1.1, July 14, 2005.

UWB MB-OFDM PER vs.Range in AWGN Environment:

UWB_OFDM_PER_vs_Range_AWGN.dsn

Features

- Signal power is -9.9 dBm
- NF is 6.6 dB

Description

The performance of the Multi-band OFDM system was evaluated in AWGN environment in this example. The simulation shall be performed with at least 500 packets with a payload of 1K bytes each. The performance simulation incorporates losses due to packet acquisition accuracy, channel estimation accuracy, carrier offset recovery accuracy and etc. The schematic of this example is shown in the following figure. The flexible parameters that users have access to are listed in "Signal_Generation_VARS", "RF_Channel_VAR" and "Measurement_VARS".

UWB_OFDM_PER_vs_Range_AWGN.dsn



UWB_OFDM_PER_vs_Range_AWGN.dsn
17

Push into to read local information

UWB OFDM: PER vs. Range in AWGN environment for MB-OFDM

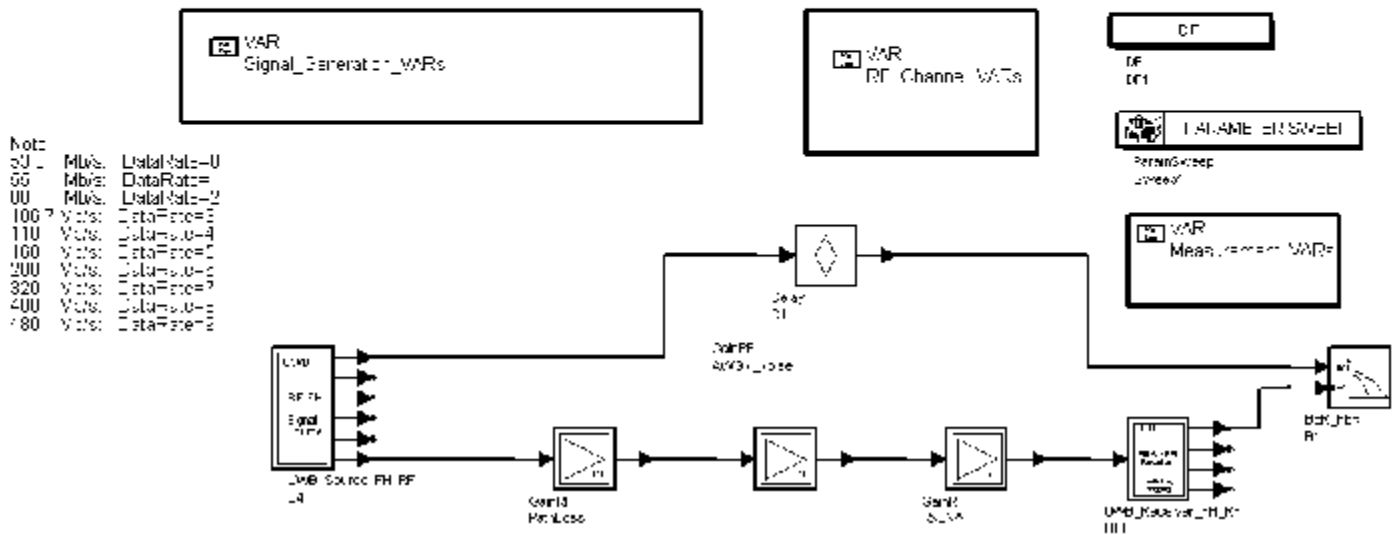

UWB_OFDM_PER_vs_Range_AWGN.dsn

Specification Requirement

The PER requirement for a Mode 1 DEV as a function of distance and information data rate in an AWGN environment is specified in [Reference 2](#), as is shown in the following figure.

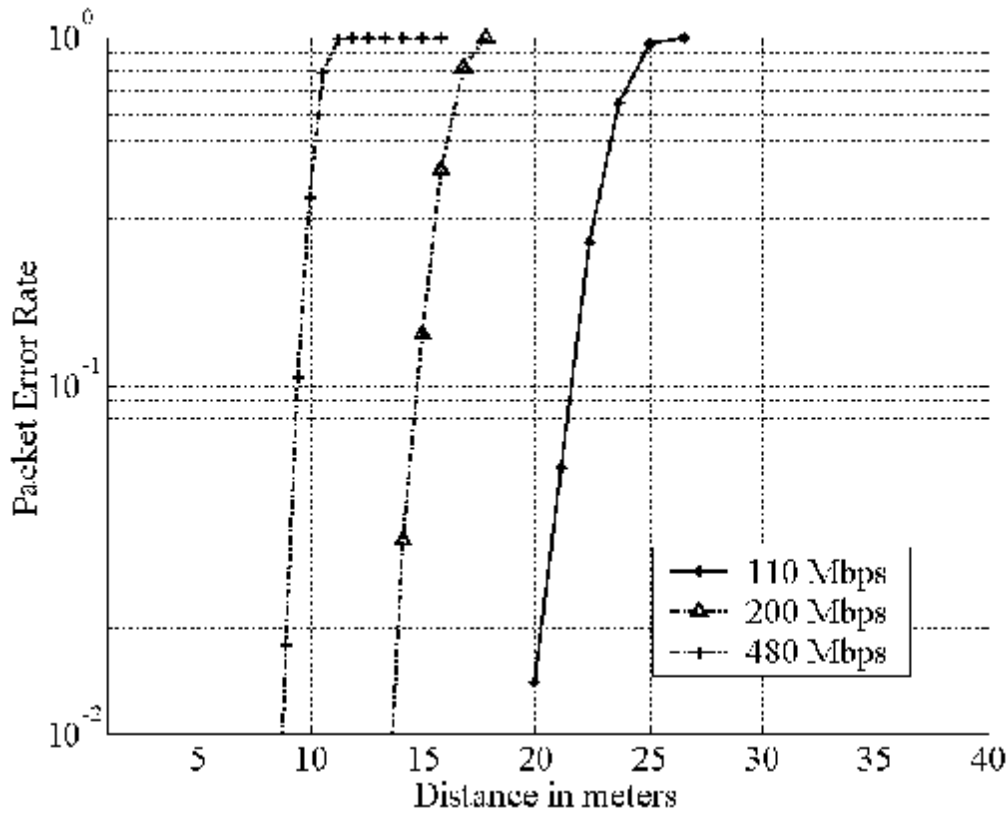

2

PER vs. Range in AWGN environment

Simulation Results

Simulation result is displayed in UWB_OFDM_PER_vs_Range_AWGN.dds, which is shown in the following figure.

PER for a Mode 1 DEV as a function of distance and information data rate, in an AWGN environment.

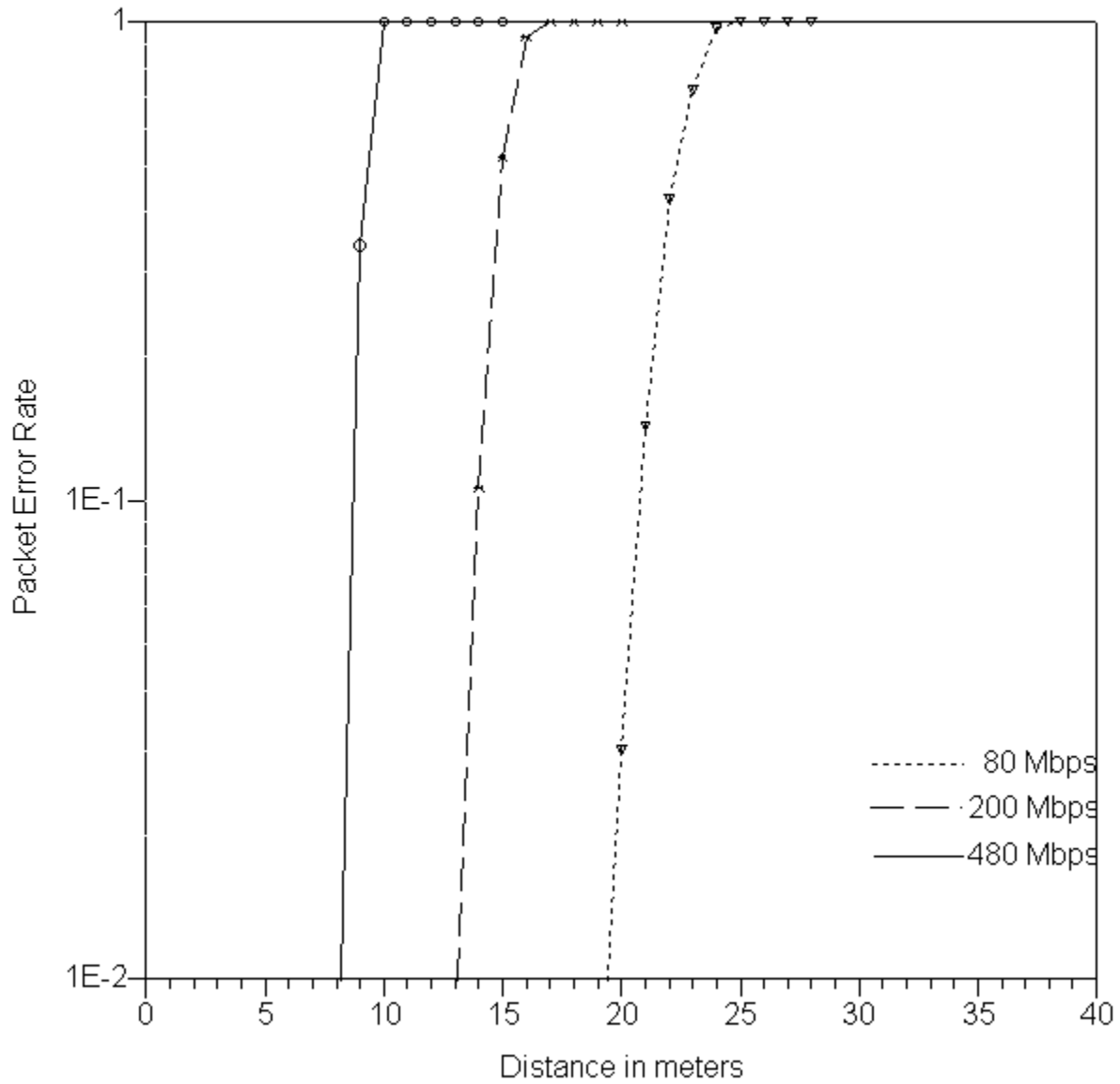

UWB_OFDM_PER_vs_Rang_AWGN.dds

Benchmark

Advanced Design System 2008

- Hardware Platform: Pentium IV 2.26 GHz, 512 MB memory
- Software Platform: Windows 2000, ADS 2004A
- Simulation Time: approximately 6 hours

References:

1. "Multiband OFDM Physical Layer Specification", WiMedia Alliance document, Release 1.1, July 14, 2005.
2. IEEE P802.15-04/0493r1, Multi-band OFDM Physical Layer Proposal for IEEE 802.15 Task Group 3a, September 2004.

UWB MB-OFDM PER vs. Range in Fading Environment:

UWB_OFDM_PER_vs_Range_Fading.dsn

Features

- Signal power is -9.9 dBm
- NF is 6.6 dB

Description

The performance of the Multi-band OFDM system was evaluated in fading environment in this example. The simulation shall be performed with at least 500 packets with a payload of 1K bytes each. The performance simulation incorporates losses due to packet acquisition accuracy, channel estimation accuracy, carrier offset recovery accuracy and etc. The schematic of this example is shown in the following figure. The flexible parameters that users have access to are listed in `Signal_Generation_VARS`, `RF_Channel_VAR` and `Measurement_VAR`.

UWB_OFDM_PER_vs_Range_Fading.dsn



Push into to read local information

UWB OFDM: PER vs. Range in fading environment for MB-OFDM

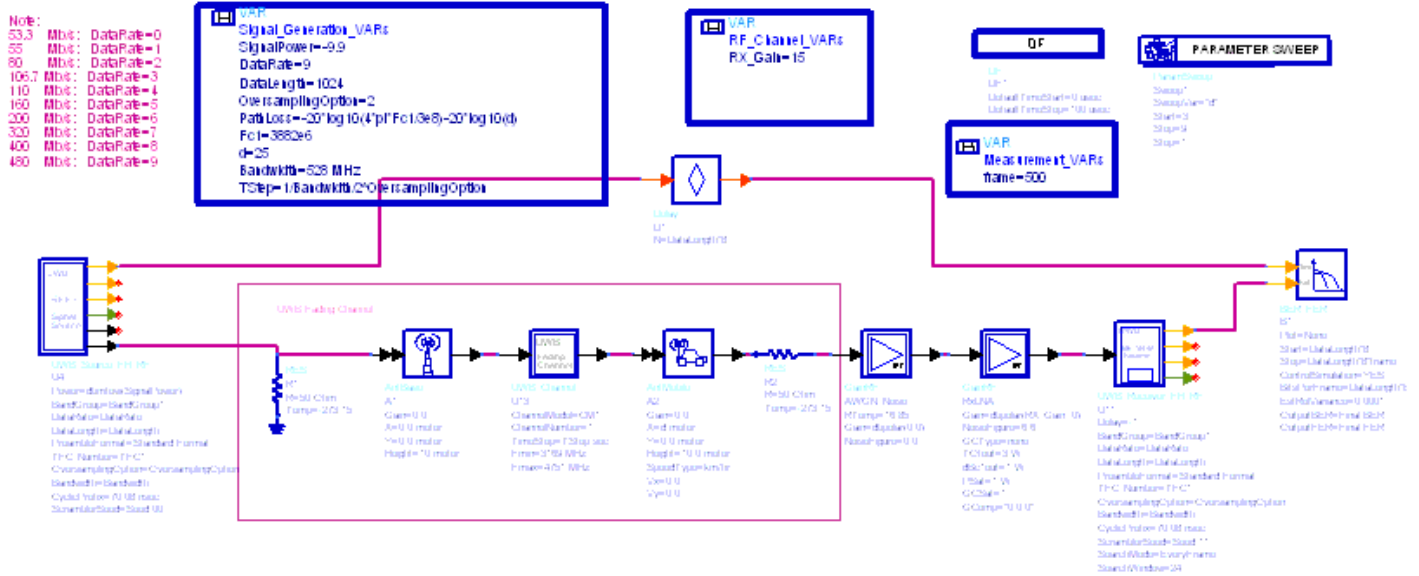

UWB_OFDM_PER_vs_Range_Fading.dsn

Simulation Results

Simulation result is displayed in UWB_OFDM_PER_vs_Range_Fading.dds, which is shown in the following figure.

PER for a Mode 1 DEV as a function of distance and information data rate in an fading environment (CM1)

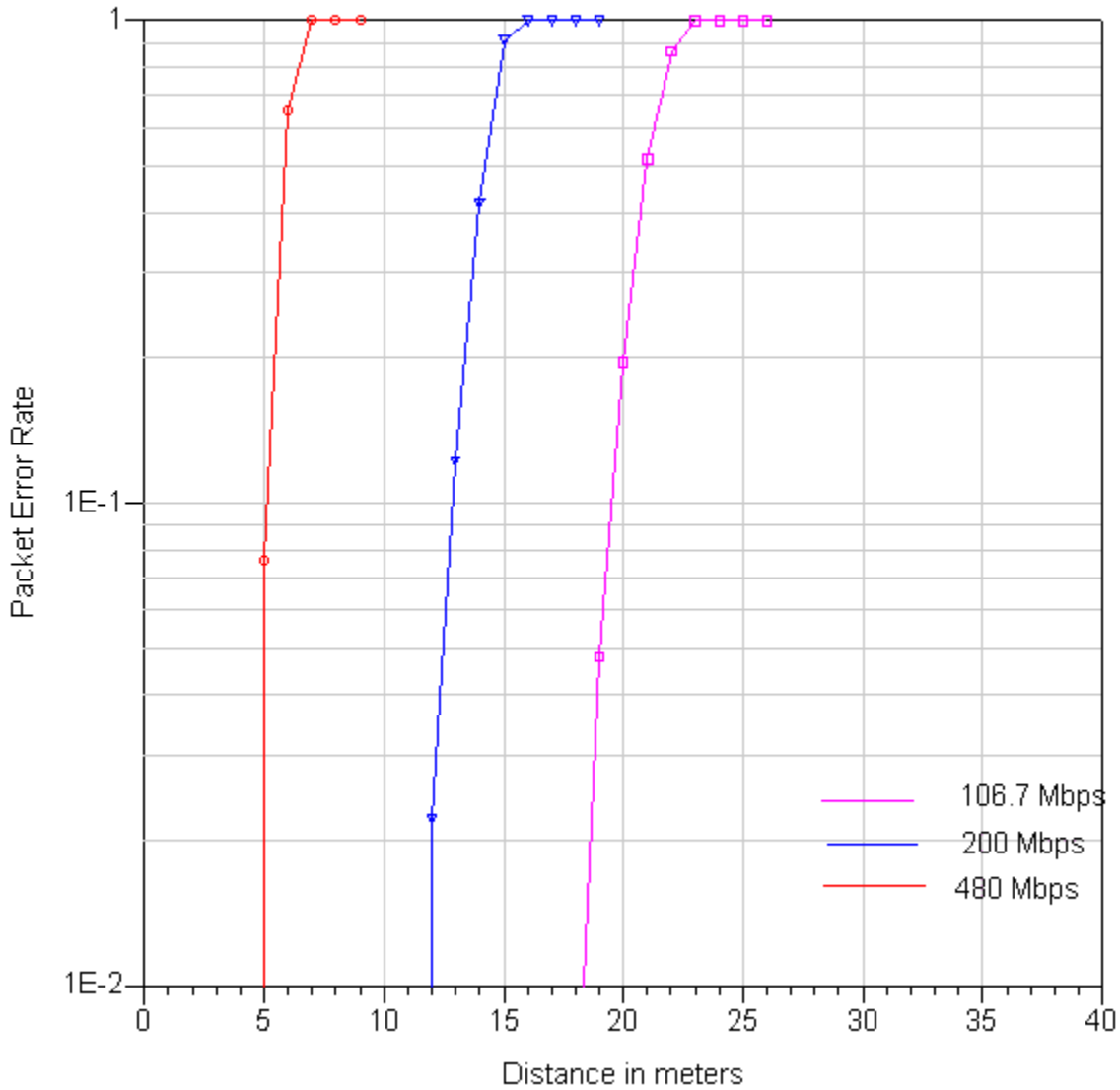

UWB_OFDM_PER_vs_Range_Fading.dds

Benchmark

- Hardware Platform: Pentium IV 2.26 GHz, 512 MB memory
- Software Platform: Windows 2000, ADS 2004A

- Simulation Time: approximately 14 hours

References:

1. "Multiband OFDM Physical Layer Specification", WiMedia Alliance document, Release 1.1, July 14, 2005.

UWB MB-OFDM Receiver Performance with ADC Effect:

UWB_OFDM_ADC_Effect.dsn

Features

- Number of bits is 4
- Reference voltage is 0.3V

Description

The ADC effect to the UWB MB-OFDM receiver is evaluated in this example. The RF signal is produced by the model `UWB_Source_FH_RF` and demodulated by `QAM_DemodExtOsc` and `UWB_Freq_Hopping`, and then the I, Q output signals are inputted into the `ADC_Timed` models respectively. The input signal is sampled at the rising zero crossing of the RF clock signal in the `ADC_Timed` model. Once a rising zero crossing is detected, linear interpolation is used to find the exact zero crossing time as well as the value of the input signal at the zero crossing time. Because the `ADC_Timed` model does not downsample the input signal; instead, it samples and holds the input signal. To downsample the output of this component, an external `DownSample` component is used. And then the parameter `OversamplingOption` of the UWB receiver should be set according to the downsample rate and the parameter `OversamplingOption` of the UWB source. The schematic of this example is shown in the following figure. The flexible parameters that users have access to are listed in `'Signal_Generation_VARS'` and `'Measurement_VARS'`.

UWB_OFDM_ADC_Effect.dsn

UWB OFDM: Receiver performance with ADC Effect



UWB_OFDM_ADC_Effect_Info Information

Push in to read local information

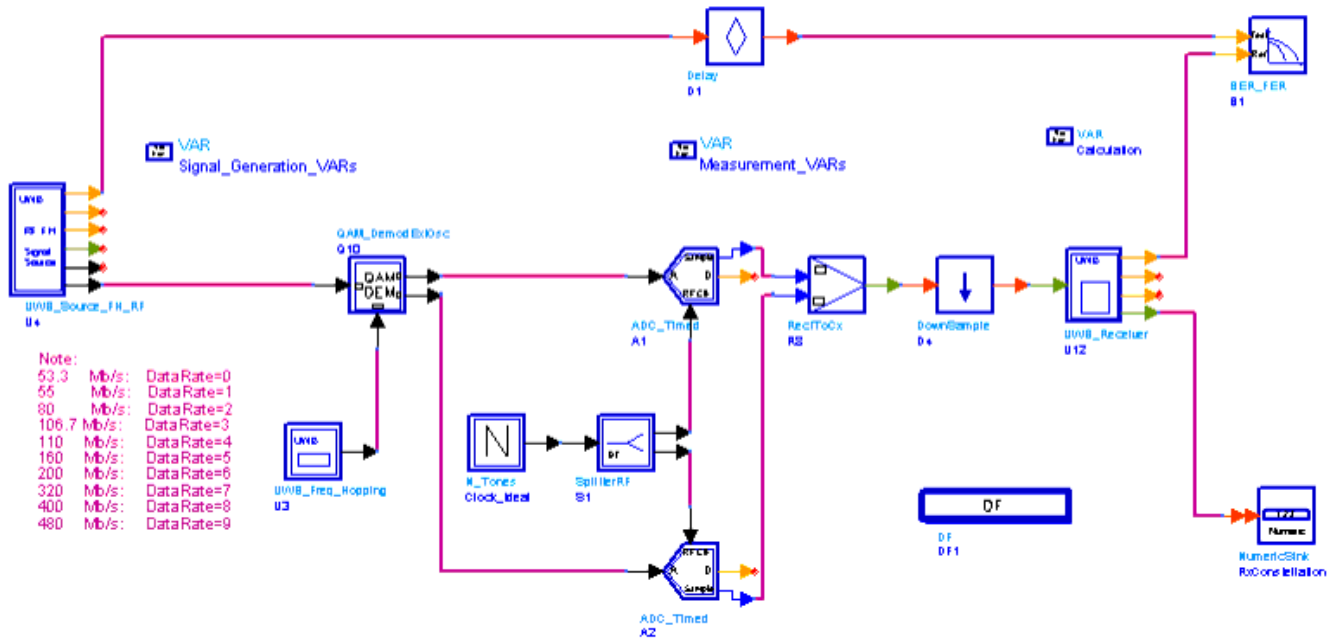

UWB_OFDM_ADC_Effect.dsn

Simulation Results

Simulation result is displayed in UWB_OFDM_ADC_Effect.dds, which is shown in the following figure.

UWB OFDM Constellation with ADC Effect

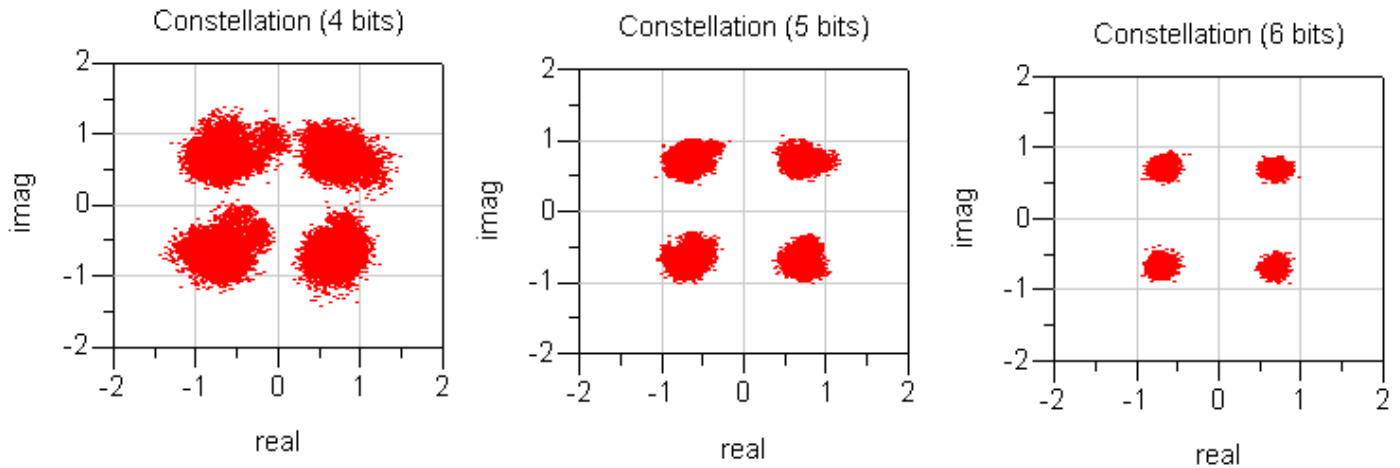

UWB_OFDM_ADC_Effect.dds

Benchmark

- Hardware Platform: Pentium IV 2.26 GHz, 1 GB memory
- Software Platform: Windows 2000, ADS 2005A
- Simulation Time: approximately 2 minutes

References:

1. "Multiband OFDM Physical Layer Specification", WiMedia Alliance document, Release 1.1, July 14, 2005.

UWB MB-OFDM Receiver Performance with WLAN 11a Interferer:

UWB_OFDM_Rx_with_WLAN_11a_Interferer.dsn

Features

- UWB signal uses BandGroup 1
- data rate is 106.7 Mbps
- Received signal power is -71.8 dBm
- NF is 6.6 dB
- WLAN 11a interference power at the Rx antenna is -17 dBm

Description

The UWB OFDM receiver performance with WLAN 11a interferer is measured in this example. The UWB signal working on BandGroup 1 occupies the spectrum from 3168 MHz to 4752 MHz, while the WLAN 11a is at 5.19 GHz with a bandwidth of 20 MHz. In this case, the 11a interferer is an out-of-band interferer.

The RF signal is generated by the model UWB_Source_FH_RF. The WLAN 11a signal is loaded by the model NumericSource. In order to display and analyze these signals, the parameter OversamplingOption of UWB source should be set to 3 or larger. At the same time, the 11a signal should be interpolated and decimated to the same sampling rate. The 11a interference is added to the UWB signal at the model SummerRF and then the AWGN is added. The UWB signal with interference and noise is sent to a bandpass filter then put into the model UWB receiver.

In this example, the WLAN 11a interference signal is generated and saved in the ds file WLAN_80211a_Source.ds in advance. It's bandwidth is 20 MHz and the sample rate is 20×32 MHz. The data rate is 54 Mbps and the data length is 1024 bytes.

The schematic of this example is shown in the following figure. The flexible parameters that users have access to are listed in 'Signal_Generation_VARS'.

UWB_OFDM_Rx_with_WLAN_11a_Interferer.dsn

UWB OFDM: Receiver performance with WLAN 11a interferer



UWB_OFDM_Rx_with_WLAN_11a_Interferer_Info Information.
 Push in to read local information

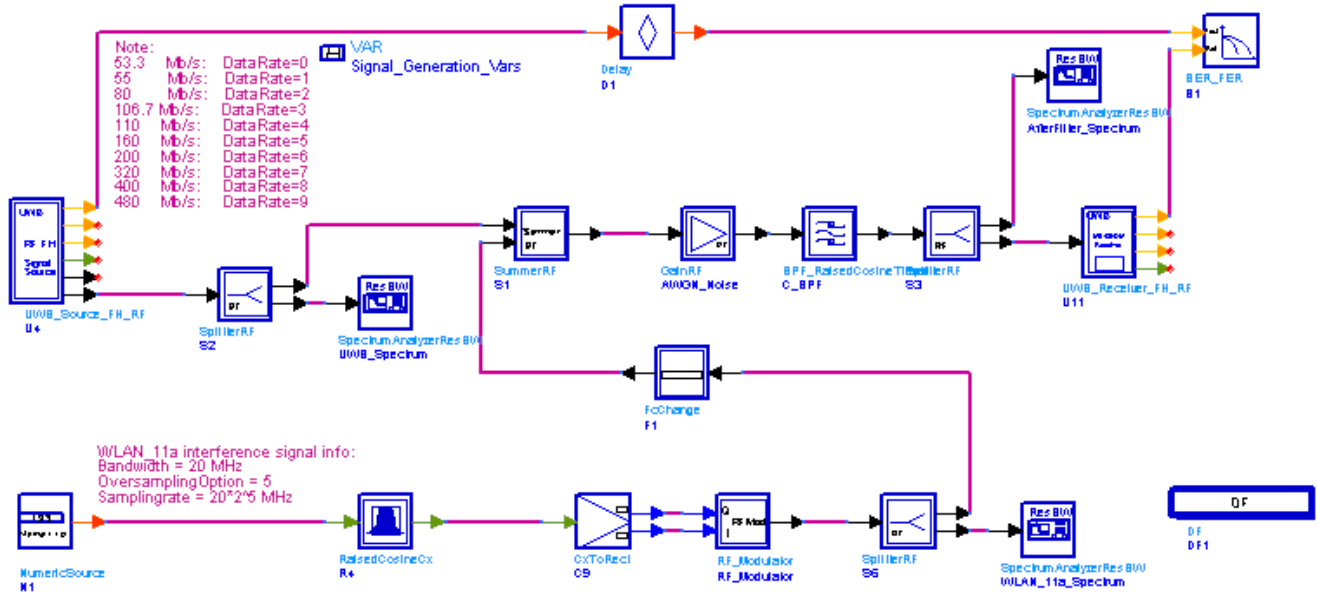

UWB_OFDM_Rx_with_WLAN_11a_Interferer.dsn

Simulation Results

Simulation result is displayed in UWB_OFDM_Rx_with_WLAN_11a_Interferer.dds, which is shown in the following figure.

UWB_OFDM_Rx_with_WLAN_11a_Interferer

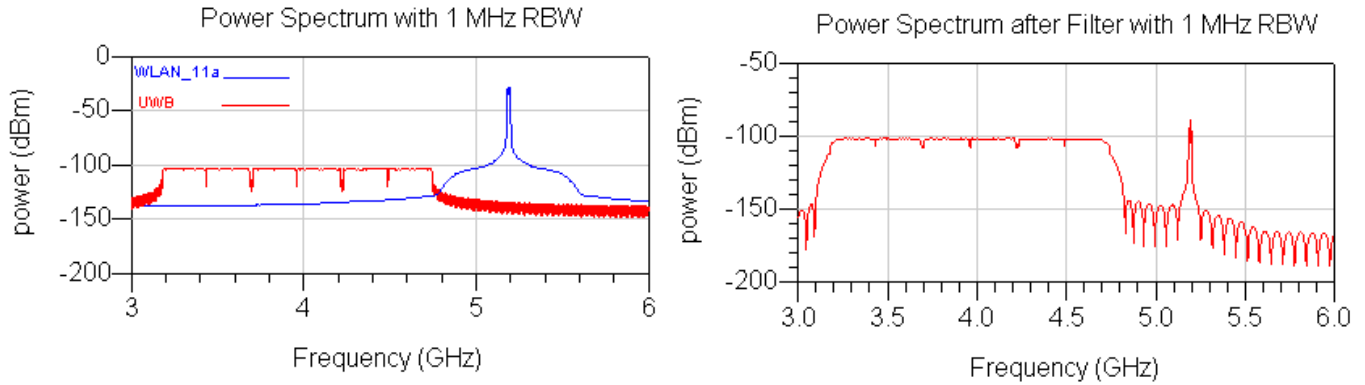

Index	BER	FER
0	0.000	0.000

UWB_OFDM_Rx_with_WLAN_11a_Interferer.dds

Benchmark

- Hardware Platform: Pentium IV 2.26 GHz, 1 GB memory
- Software Platform: Windows 2000, ADS 2005A
- Simulation Time: approximately 8 hours

References:

1. "Multiband OFDM Physical Layer Specification", WiMedia Alliance document, Release 1.1, July 14, 2005.

UWB MB-OFDM Receiver Performance with WiMax Interferer:

UWB_OFDM_Rx_with_WiMax_Interferer.dsn

Features

- UWB signal uses BandGroup 1
- data rate is 80 Mbps
- Received signal power is -71.8 dBm
- WiMax interference power at the Rx antenna is -78.8 dBm

Description

The UWB OFDM receiver performance with WiMax interferer is measured in this example. The UWB signal working on BandGroup 1 occupies the spectrum from 3168 MHz to 4752 MHz, while the WiMax can work from 2 GHz to 5 GHz and the bandwidth is no more than 20 MHz. In this example, the WiMax interferer is set to be an in-band interferer.

The RF signal is produced by the model UWB_Source_FH_RF. The WiMax signal is loaded by the model NumericSource. In order to display and analyze these signals, the parameter OversamplingOption of UWB source should be set to 2 or larger. At the same time, the WiMax signal should be interpolated and decimated to the same sampling rate. The WiMax interference is added to the UWB signal at the model SummerRF and then the AWGN is added. The UWB signal with interference and noise is sent to a bandpass filter then put into the model UWB receiver.

In this example, the WiMax interference signal is generated and saved in the ds file WMAN_OFDMA_10M.ds in advance. It's bandwidth is 10 MHz and the sample rate is 11.2 MHz. The schematic of this example is shown in the following figure. The flexible parameters that users have access to are listed in "Signal_Generation_VARS".

UWB_OFDM_Rx_with_WiMax_Interferer.dsn

UWB OFDM:Receiver performance with WiMax interferer



UWB_OFDM_Rx_with_WiMax_Interferer_Info
Information

Push in to read local information

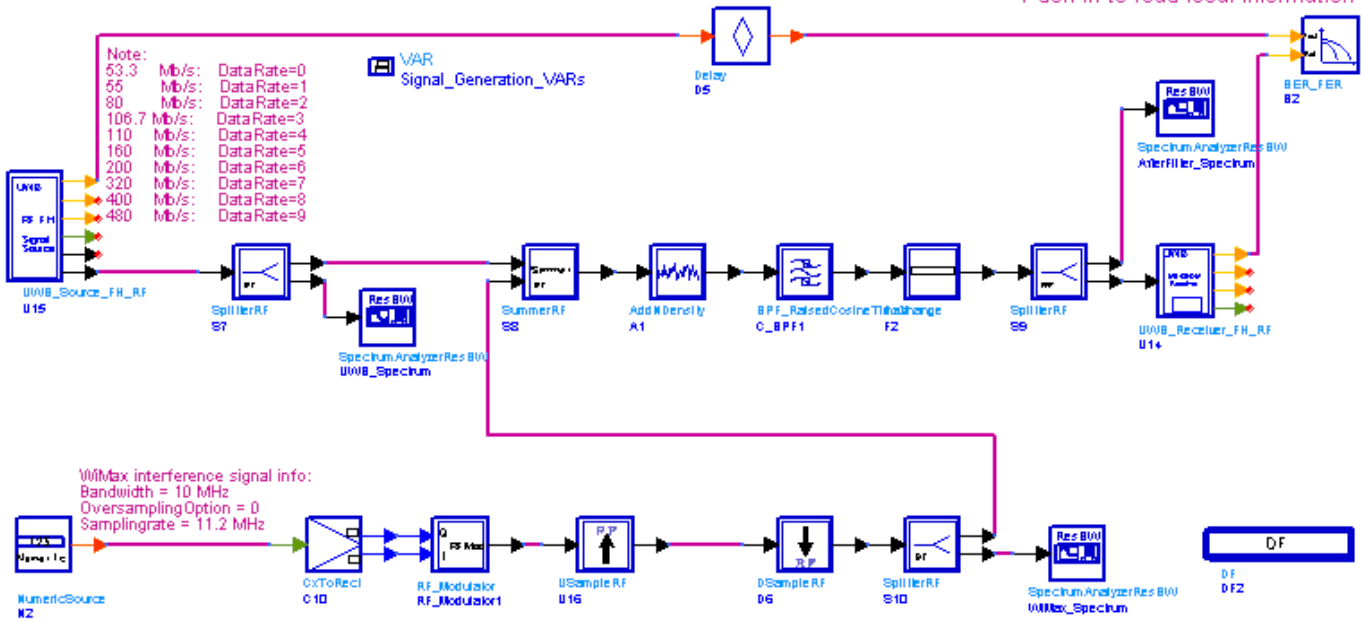

UWB_OFDM_Rx_with_WiMax_Interferer.dsn

Simulation Results

Simulation result is displayed in UWB_OFDM_Rx_with_WiMax_Interferer.dds, which is shown in the following figure.

UWB_OFDM_Rx_with_WiMax_Interferer

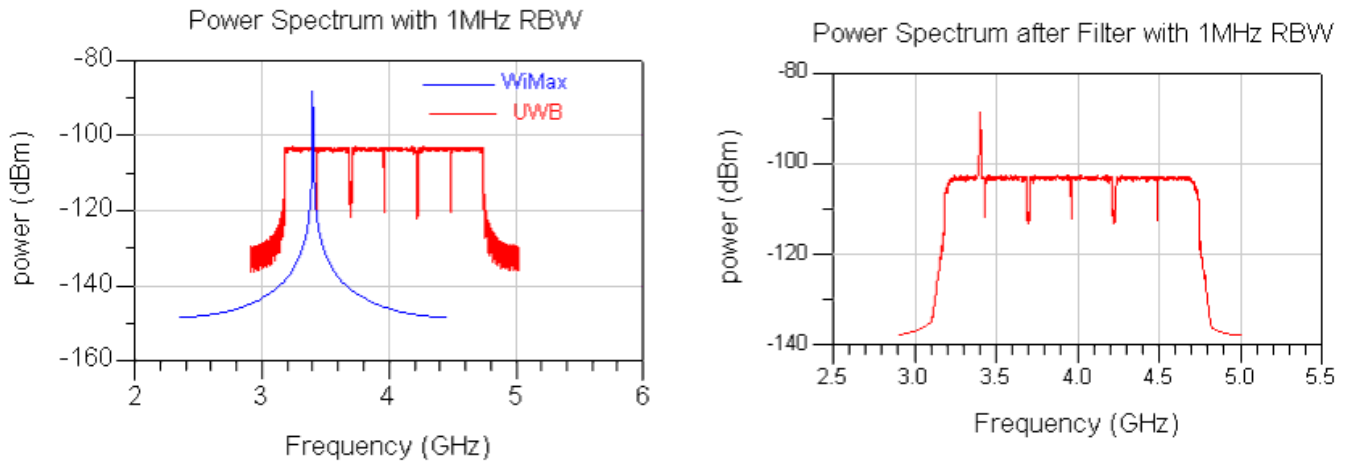

Index	BER	FER
0	0.000	0.000

UWB_OFDM_Rx_with_WiMax_Interferer.dds

Benchmark

- Hardware Platform: Pentium IV 2.26 GHz, 1 GB memory
- Software Platform: Windows 2000, ADS 2005A
- Simulation Time: approximately 3.5 hours

References:

1. "Multiband OFDM Physical Layer Specification", WiMedia Alliance document, Release 1.1, July 14, 2005.
2. IEEE P802.15-04/0493r1, Multi-band OFDM Physical Layer Proposal for IEEE 802.15 Task Group 3a, September 2004.

UWB Transmitter Design Examples

Introduction

UWB_OFDM_Tx_prj provides UWB transmitter test and measurement design examples, which are built up based on WiMedia Multiband OFDM Physical Layer Specification, release 1.1:

- UWB_OFDM_Demo.dsn: demonstrates an example of encoding a frame of Multi-band OFDM PHY.
- UWB_OFDM_TxCCDF.dsn: measures Complementary Cumulative Distribution Function of the transmitted signal
- UWB_OFDM_TxEVM.dsn: measures error vector magnitude and records constellations of reference signal and signal to be measured. The transmitter is UWB RF signal source with frequency hopping and provides reference signal.
- UWB_TxSpectrum.dsn: measures transmit PSD mask.

Example of Encoding a Packet for the Multi-band OFDM PHY

UWB_OFDM_Demo.dsn

Features

- PHY header rate of 53.3 Mbps
- Payload data rate of 200 Mbps
- The entire packet at the output of the transmitter
- All details of the encoding can be got by inserting sink in the proper position

Description

This design is used to verify the signal generator UWB_SignalSource in UWB design library using the same setting as the example in Annex A in [Reference 1](#). The schematic of this design is shown in the following figure.

UWB_OFDM_Demo.dsn

UWB OFDM: An example of Encoding a packet for the Multi-band OFDM PHY

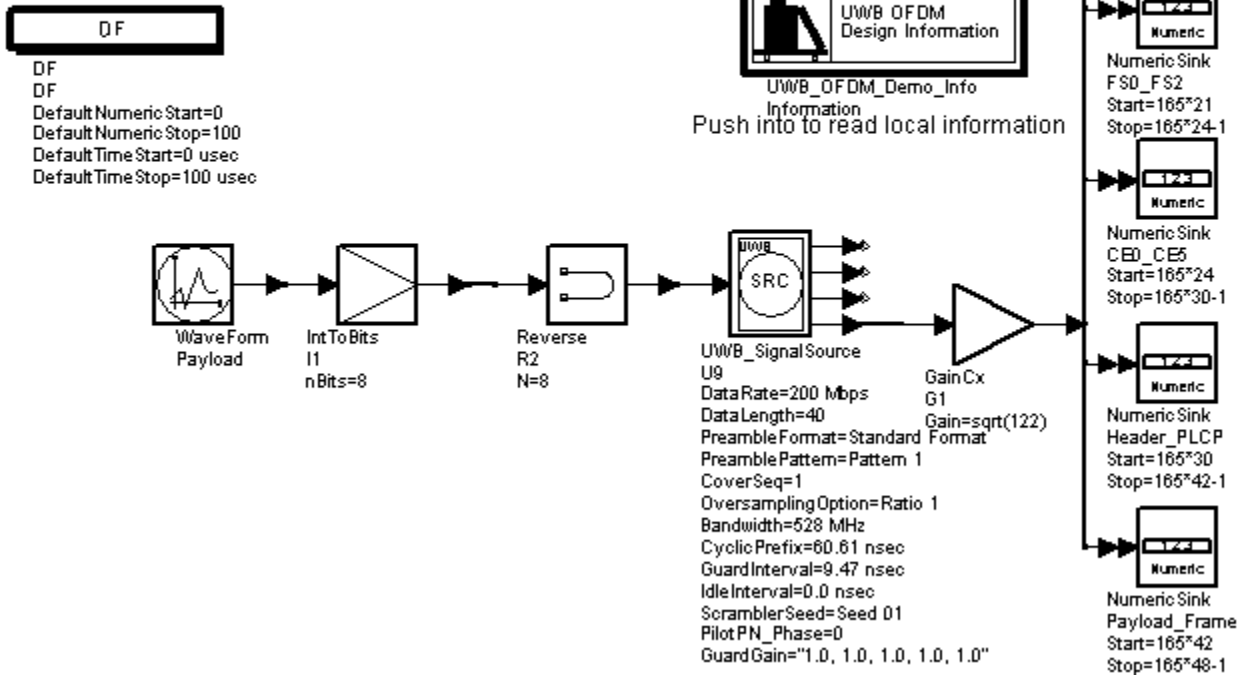

UWB_OFDM_Demo Schematic

Model Payload in this schematic generate the 40-byte packet for transmission shown in [Table A10.1 in Reference 1](#).

The signal is converted into bits by I1.

Since in ADS generally MSB is transmitted first, while according to the spec, the LSM is transmitted first, R2 is inserted to make sure the order of transmission is correct.

U9 is the signal source generator.

The signal is normalized in U9, while the data in table A12 in [Reference 1](#) are not normalized. So G1 is added to match them.

Five NumericSinks are used to record the data of packet synchronization sequence, frame synchronization sequence, channel estimation sequence, PLCP Header and PLCP PSDU respectively.

The parameters chosen for illustration are listed in the table below.

Advanced Design System 2008

Time Frequency Code (TFC)	1
Preamble Mode (Standard/Shortened)	Standard
Data Rate	200 Mbps
Modulation	QPSK
Coding Rate	5/8
Conjugate Symmetric?	No
Time Spreading Factor (TSF)	2
Number of Coded Bits per OFDM Symbol (Ncbps)	200
Phy header: rate bits R1:R5	00100
Phy header: PLCP Length (bytes)	40
PLCP Scrambler Field S1:S2	01
Preamble Bit	0
Burst mode bit	1

Simulation Results

Simulation results displayed in UWB_OFDM_Demo.dds are shown in the following two figures.

PLCP Preamble

Index	FS0_FS23	Index	CE0_CE5
0	7.2502 - j1.5329E-15	3960	9.8995 + j0.0000
1	-15.1001 + j3.5207E-15	3961	-7.2562 - j5.4364E-15
2	-10.9990 + j3.0657E-15	3962	-8.4976 - j5.2598E-15
3	-15.4425 + j1.1075E-14	3963	7.0257 + j8.4000E-15
4	9.3676 + j1.6302E-15	3964	0.3928 + j7.8505E-17
5	12.0306 - j3.7172E-15	3965	17.7030 + j2.9125E-14
6	-9.5222 - j1.4945E-15	3966	-11.7901 - j1.7899E-14
7	12.7154 - j7.6640E-16	3967	12.3091 + j2.2138E-14
8	10.6058 + j4.7672E-17	3968	-11.7563 - j9.2635E-15
9	-15.0007 + j5.8248E-15	3969	5.3317 + j3.8860E-15
10	-9.2273 - j1.5330E-16	3970	7.2923 + j2.0176E-14
11	-14.6340 + j7.0511E-15	3971	-2.5968 - j4.3178E-15
12	12.1101 + j3.5815E-15	3972	16.7493 + j2.5200E-14
13	14.7279 - j1.9927E-15	3973	-3.8235 - j1.1776E-15
14	-8.1493 - j1.0730E-15	3974	-2.2717 - j4.8673E-15
15	14.9830 - j3.8321E-15	3975	-0.0808 - j3.4542E-15
16	10.3396 + j1.2100E-15	3976	6.0000 + j7.0654E-15
17	-9.0705 + j4.5315E-15	3977	-12.8722 - j1.9136E-14
18	-2.9403 + j5.0584E-15	3978	-12.9997 - j1.7585E-14
19	-7.5837 + j4.1387E-15	3979	-7.5541 - j1.6172E-14
20	9.3190 + j3.3930E-15	3980	17.4249 + j1.8684E-14
21	12.4117 - j1.5331E-16	3981	-12.2915 - j2.2374E-14
22	-3.6063 + j7.6644E-16	3982	-3.9802 - j1.8998E-14
23	11.6098 - j1.9160E-15	3983	17.4186 + j5.0086E-14
24	8.7557 + j3.0180E-15	3984	0.5597 - j4.5533E-15
25	-3.7146 - j9.1973E-16	3985	-11.3055 - j3.4895E-14
26	-1.4823 + j1.3796E-15	3986	-20.2687 - j3.4385E-14
27	-1.7076 + j1.5329E-15	3987	-12.5852 - j3.8075E-14
28	7.6820 + j5.1579E-16	3988	-0.7328 - j9.1458E-15
29	11.7169 + j1.9927E-15	3989	18.6881 + j5.5817E-14
30	-1.7673 - j1.5327E-16	3990	1.3508 + j9.9505E-15
31	10.4290 + j2.4526E-15	3991	-10.9864 - j5.2598E-14
32	-0.9322 - j1.6137E-15	3992	18.3848 + j1.0029E-14

Note: This tables are the same as Table A7, A8 in WiMedia MultiBand OFDM Physical Layer Specification Release 1.1 except that the index starts from 0.

Index	Header_PLCP	Index	Payload_Frame
4950	-24.0416 + j0.0000	6930	5.6569 - j15.5564
4951	17.0934 + j1.2436E-14	6931	-7.3256 - j5.8859
4952	-10.1885 - j1.0408E-14	6932	-3.4562 + j8.0375
4953	-3.7917 - j6.9509E-15	6933	-2.1729 - j3.4839
4954	6.1113 + j3.0006E-15	6934	3.1765 + j0.6754
4955	3.1685 + j5.3307E-15	6935	0.2959 + j6.3641
4956	-4.3795 - j7.4385E-15	6936	4.7368 + j9.7582
4957	-18.1249 - j4.2530E-14	6937	-4.9815 + j7.4272
4958	0.8659 + j5.9636E-15	6938	10.8796 + j2.0273
4959	17.0610 + j2.6258E-14	6939	-0.9253 - j1.4276
4960	5.4753 + j3.3029E-15	6940	-11.7830 - j1.9553
4961	6.8694 + j1.0712E-14	6941	-8.6512 - j8.4905
4962	8.7059 + j7.0747E-15	6942	-7.6180 + j3.8784
4963	5.6139 + j1.9285E-14	6943	-3.1359 - j2.1070
4964	16.4724 + j3.6748E-14	6944	2.5044 - j9.5182
4965	-11.3538 - j3.3558E-14	6945	-5.5661 + j3.7362
4966	5.1716 + j6.5805E-15	6946	-5.6569 - j3.6569
4967	0.8281 + j2.9992E-15	6947	5.2865 - j0.2268
4968	-13.3243 - j2.8644E-14	6948	10.5334 + j19.4120
4969	12.7665 + j2.1204E-14	6949	0.1996 + j16.8985
4970	-8.5005 - j1.0391E-14	6950	-7.8014 - j1.1601
4971	0.2355 + j1.2159E-14	6951	4.2362 + j6.4591
4972	14.9466 + j2.4397E-14	6952	-7.9485 + j2.1321
4973	1.9262 + j6.7499E-15	6953	0.0994 + j13.2728
4974	-2.7422 - j3.9652E-15	6954	-2.6643 + j7.9382
4975	12.6604 + j2.4593E-14	6955	7.2059 + j3.6947
4976	21.4445 + j3.9524E-14	6956	-0.6246 + j2.3534
4977	14.5548 + j4.3408E-14	6957	2.0810 - j5.0736
4978	23.8425 + j4.8139E-14	6958	-1.5367 + j2.5028
4979	-7.1320 - j1.1427E-14	6959	-2.0227 - j6.0615
4980	3.1928 + j2.3204E-14	6960	-5.2936 - j7.0084
4981	-11.7240 - j5.0309E-14	6961	3.6447 - j1.7857
4982	9.8995 + j1.0029E-14	6962	8.4853 - j4.2426

Note: This tables are the same as Table A9-A26 in WiMedia MultiBand OFDM Physical Layer Specification Release 1.1 except that the index starts from 0.

PLCP Header and Frame payload

Benchmark

- Hardware platform: Pentium IV 1.7 GHz, 512 MB memory
- Software platform: Windows 2000 Workstation, ADS 2004A
- Simulation time: approximately 20 seconds

References

1. "Multiband OFDM Physical Layer Specification", WiMedia Alliance document, Release 1.1, July 14, 2005.

Complementary Cumulative Distribution Function Measurement

UWB_OFDM_TxCCDF.dsn

Features

- CCDF measurement
- UWB RF signal source with frequency hopping used
- DataRate 80 Mb/s used
- Waveform of transmitted signal also provided

Description

This design is used to measure CCDF of UWB RF signal source with frequency hopping. The schematic of this design is shown in the following figure.

UWB_OFDM_TxCCDF.dsn



Push into Info to read local information

UWB OFDM: Transmitter CCDF measurement for MB-OFDM

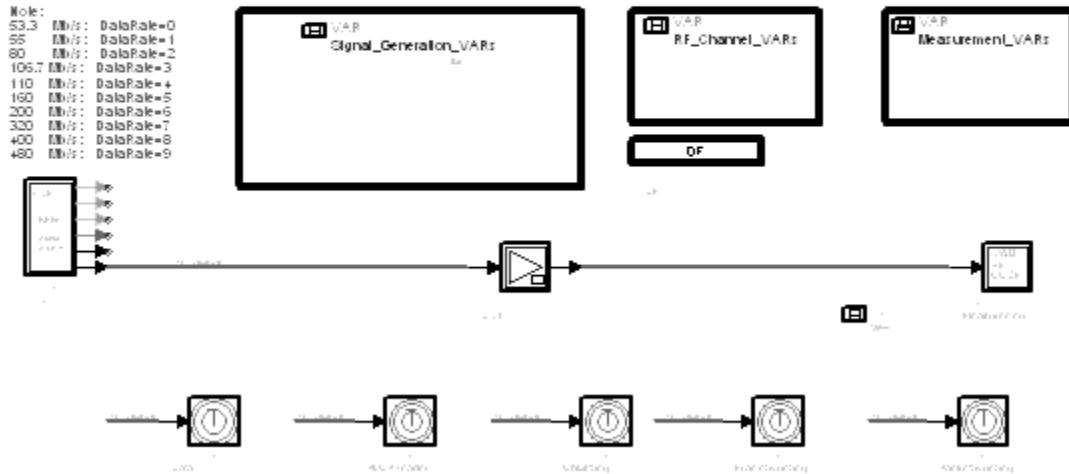

UWB_OFDM_TxCCDF.dsn Schematic

The Signal_Generation_VARS incorporates parameters used to configure the UWB_Source_FH_RF and Measurement_VARS incorporates parameters used to configure UWB_RF_CCDF, which is the CCDF measurement model.

The five TimedSinks are used to record the waveforms of packet synchronization sequence, frame synchronization sequence, channel estimation sequence, PLCP Header and PLCP PSDU respectively.

Simulation Results

Simulation results displayed in UWB_OFDM_TxCCDF.dds are shown in the following two figures.

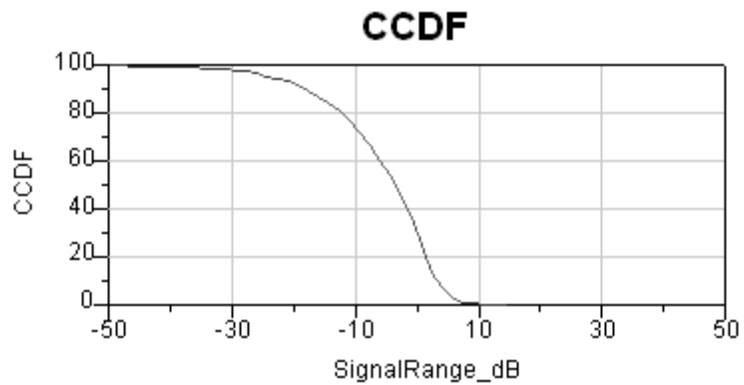

CCDF of UWB_Source_FH_RF

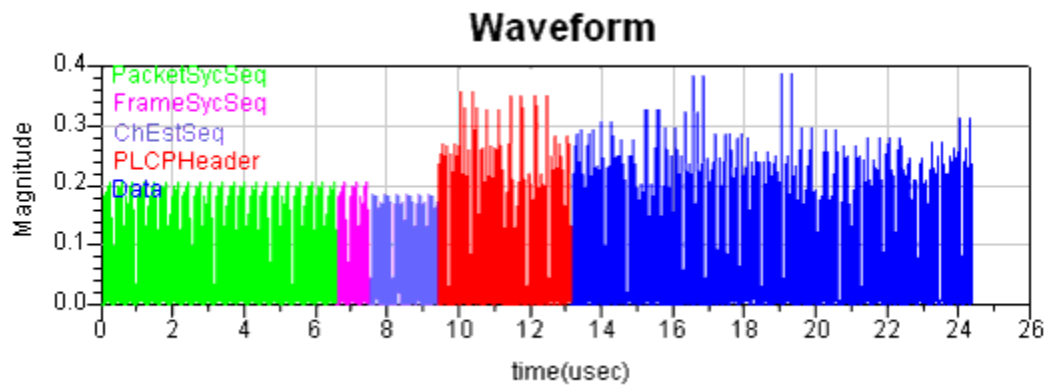

Waveform of UWB_Source_FH_RF

Benchmark

- Hardware platform: Pentium IV 2.26 GHz, 512 MB memory
- Software platform: Windows 2000 Workstation, ADS 2004A
- Simulation time: approximately 400 seconds

References

1. "Multiband OFDM Physical Layer Specification", WiMedia Alliance document, Release 1.1, July 14, 2005.

Error Vector Magnitude without Reference Signal

UWB_OFDM_TxEVM.dsn

Features

- Support frequency hopping signal and non frequency hopping signal
- Support EVM measurement and constellation output
- Consistent measurement results with Agilent 89600 software

Description

This design measures transmit modulation accuracy of UWB MB-OFDM RF frequency hopping signal source.

The schematic for this design is shown in the following figure.

Transmitter EVM measurement for MB-OFDM

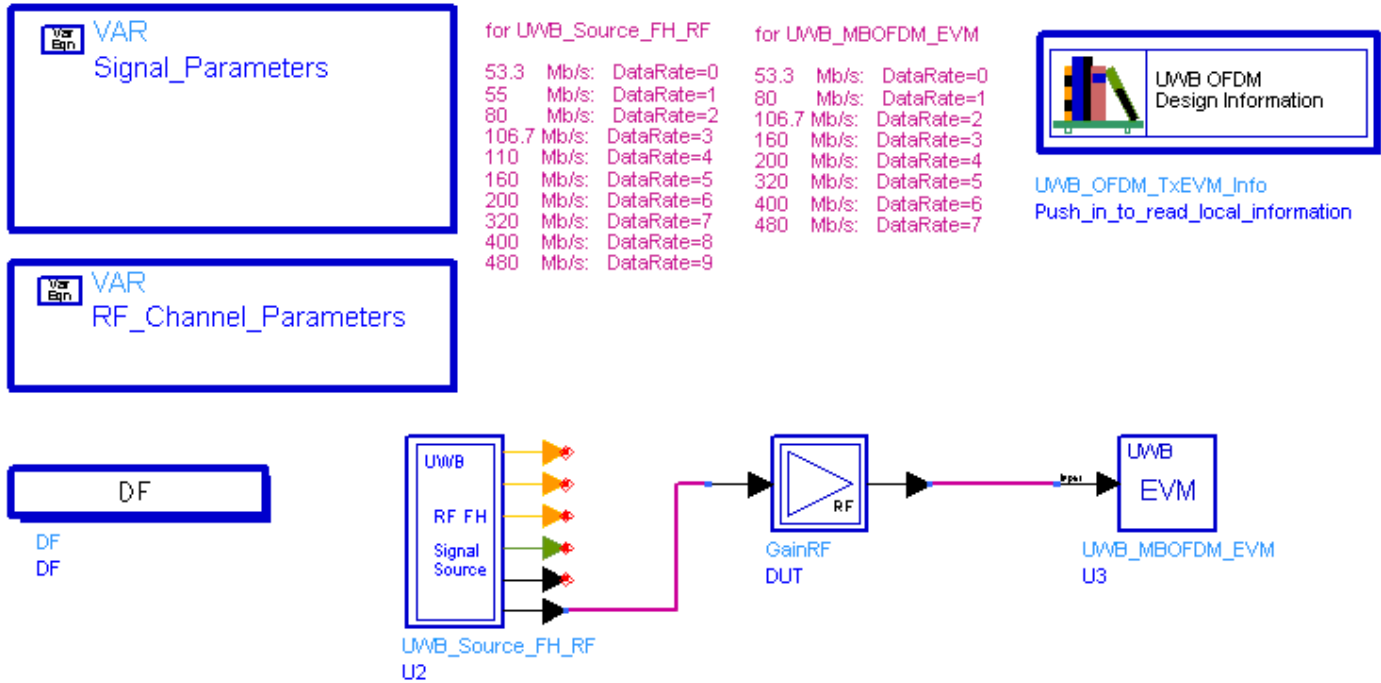

UWB_EVM Schematic

UWB_Source_FH_RF generates the ideal signal waveform which is fed to the Device Under Test (DUT) GainRF. Output signal of GainRF is the distorted signal to be measured. Model UWB_MBOFDM_EVM is used to measure EVM (or Relative Constellation Error, RCE), carrier frequency offset as well as other aspects of the input signal. Model UWB_MBOFDM_EVM uses the same algorithm as that in Agilent 89600 software, and thus the measurement results shall be consistent with the latter.

Note that, for getting reasonable measurement results, parameters of the UWB_MBOFDM_EVM model should be consistent with the corresponding input signal. For more details on UWB_MBOFDM_EVM, see document of this model.

Simulation Results

Simulation results in the Data Display System are shown in the following figure, which includes the average EVM measurement result in dB and percentage, EVM results of each successfully analyzed frame and constellation of these measured frames. Here the constellation is of the PSDU part of the measured DCM signal.

EVM Result (average)

Index	Avg_RCE_dB	Avg_RCE_rms_percent
0	-26.927	4.506

EVM Result (sub-frame)

RCE_dB DF Frame	RCE_dB	RCE_rms_percent
1	-26.713	4.617
2	-26.721	4.613
3	-26.835	4.553
4	-27.154	4.388
5	-27.213	4.359

Constellation

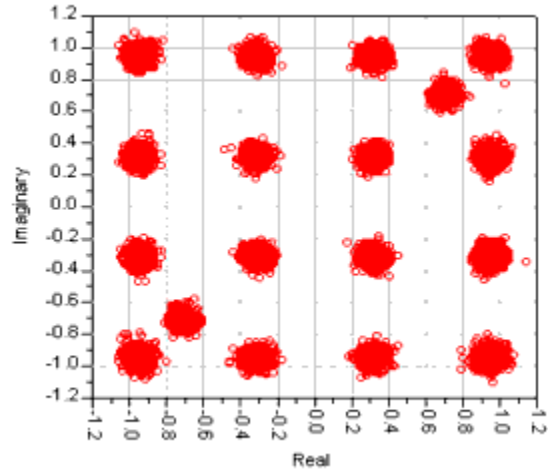

Measurement results

Benchmark

- Hardware platform: Pentium IV 2.26 GHz, 512 MB memory
- Software platform: Windows 2000 Professional, ADS 2005A
- Simulation time: approximately 2 minutes

References

1. "Multiband OFDM Physical Layer Specification", WiMedia Alliance document, Release 1.1, July 14, 2005.

Transmit Spectrum Measurement for UWB MB-OFDM System

UWB_OFDM_TxSpectrum.dsn

Features

- UWB MB-OFDM configurable signal source
- Adjustable sample rate by setting OversamplingOption
- Spectrum analysis
- Integrated RF section

Description

This example demonstrates the UWB MB-OFDM transmitter signal power spectrum density. And this example is designed for TFC number 1. User can test other patterns by setting Sim_VAR to appropriate values. For example, in order to measure the power spectrum density in band #2 when TFC number=1 and Preamble Format=Standard Format, the start time for data recording of the SpectrumAnalyzer can be $(312.5 \times 46 + 70.08) \text{ nsec}$, and the stop time for data recording of the SpectrumAnalyzer can be $(312.5 \times 46 + 70.08 + 242.424242) \text{ nsec}$, where 312.5nsec is the symbol interval, 70.08nsec is the zero pad duration, 242.424242nsec is the IFFT/FFT period, 46 is the symbol number which points to the band #2.

The measurements in this design are based on section 1.5.1 of [Reference 1](#). The transmitted spectrum shall have a 0 dBr (dBr relative to the maximum spectral density of the signal) bandwidth not exceeding 260 MHz, -12 dBr at 285 MHz frequency offset, -20 dBr at 330 MHz frequency offset and above. The transmitted spectral density of the transmitted signal shall fall within the spectral mask, as shown in the following figure.

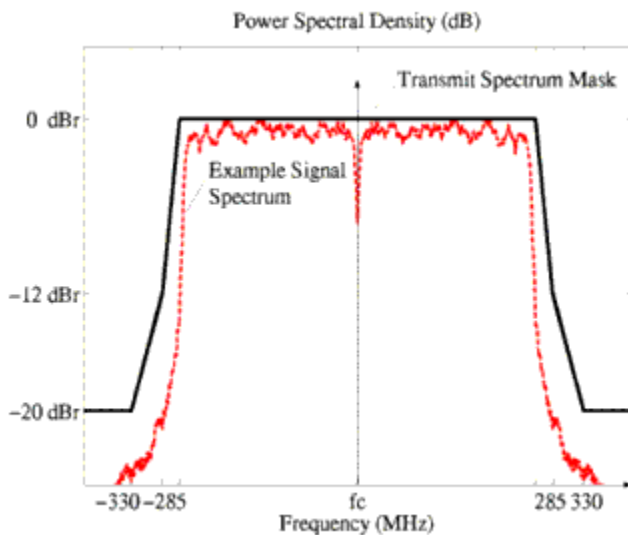

Transmit spectrum mask

Schematics

UWB_OFDM_TxSpectrum

UWB OFDM: Transmitter PSD measurement



U4

Push into info to read local information

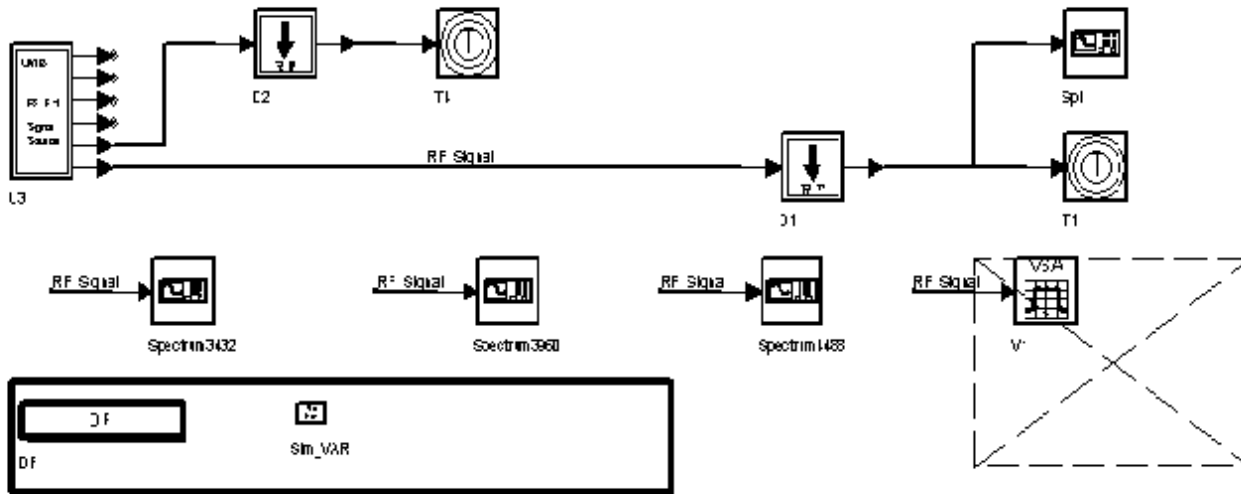

UWB_OFDM_TxSpectrum.dsn Schematic

Simulation Results

Simulation results are displayed in UWB_OFDM_TxSpectrum.dds. The following figure shows the power spectrum density (red line) of the transmitted signals at 3 different bands, together with the spectrum mask (blue line).

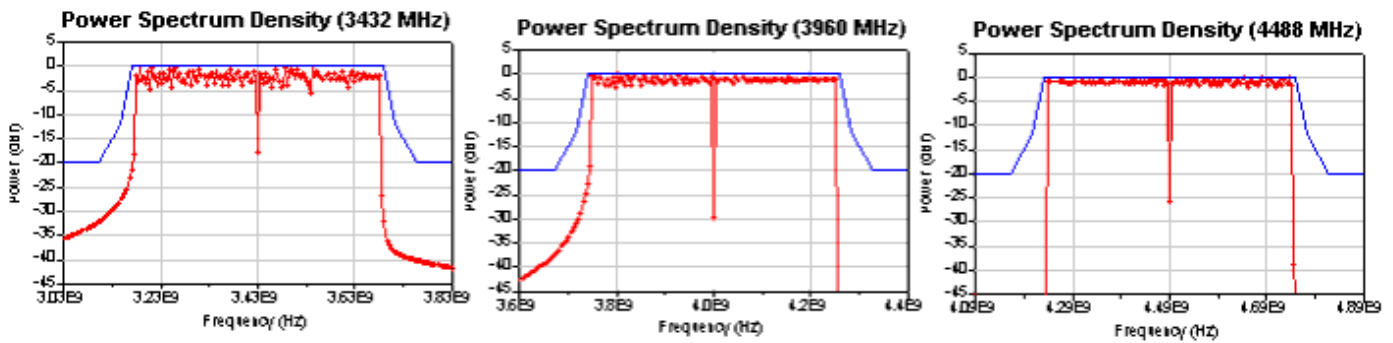

Power Spectrum Density

The following figure shows the power spectrum density of the multi-band signals at 1MHz resolution bandwidth, together with the FCC mask.

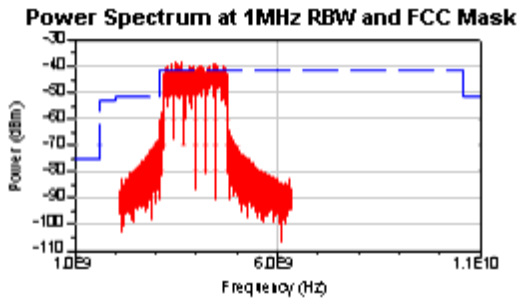

Power spectrum at 1MHz RBW

The following figure shows the LO instantaneous frequency versus time.

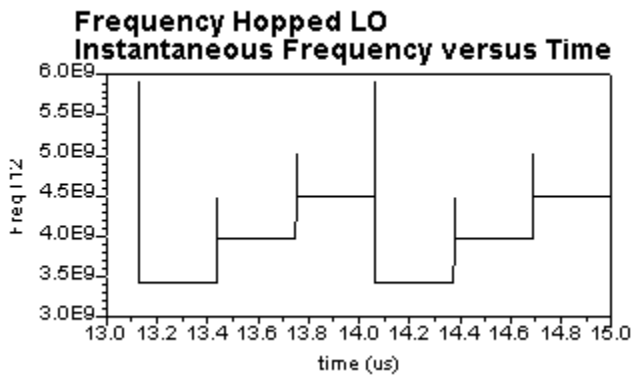

Hopped LO vs. Time

The following figure shows the TX signal instantaneous frequency versus time.

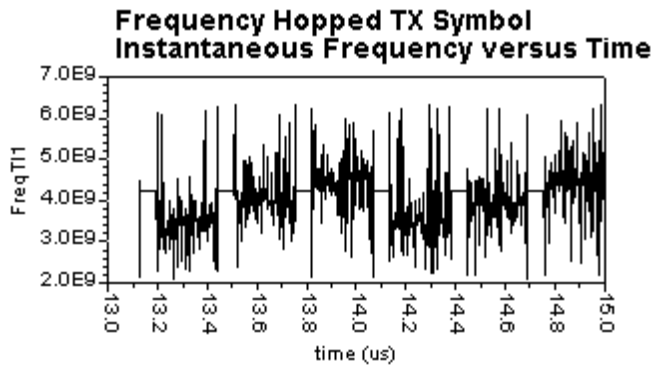

Hopped signal vs. Time

The following figure shows the real part of the baseband signal versus time.

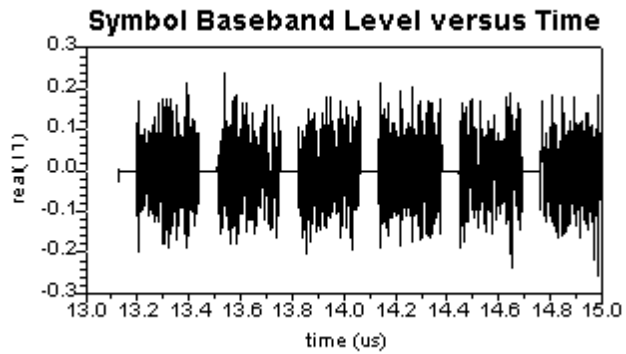

Baseband signal vs. Time

Benchmark

- Hardware Platform: Pentium IV 2.26 GHz, 512 MB memory
- Software Platform: Windows 2000, ADS 2004A
- Simulation Time: approximately 77 seconds

References

1. "Multiband OFDM Physical Layer Specification", WiMedia Alliance document, Release 1.1, July 14, 2005