



**Agilent Technologies**

ADS 2008  
January 2008

Vendor Component Libraries - muRata Manufacturing Measurement-Based SMT Library

## Advanced Design System 2008

© Agilent Technologies, Inc. 2000-2008

395 Page Mill Road, Palo Alto, CA 94304 U.S.A.

No part of this manual may be reproduced in any form or by any means (including electronic storage and retrieval or translation into a foreign language) without prior agreement and written consent from Agilent Technologies, Inc. as governed by United States and international copyright laws.

### Acknowledgments

Mentor Graphics is a trademark of Mentor Graphics Corporation in the U.S. and other countries. Microsoft®, Windows®, MS Windows®, Windows NT®, and MS-DOS® are U.S. registered trademarks of Microsoft Corporation. Pentium® is a U.S. registered trademark of Intel Corporation. PostScript® and Acrobat® are trademarks of Adobe Systems Incorporated. UNIX® is a registered trademark of the Open Group. Java™ is a U.S. trademark of Sun Microsystems, Inc. SystemC® is a registered trademark of Open SystemC Initiative, Inc. in the United States and other countries and is used with permission. MATLAB® is a U.S. registered trademark of The Math Works, Inc.. HiSIM2 source code, and all copyrights, trade secrets or other intellectual property rights in and to the source code in its entirety, is owned by Hiroshima University and STARC.

**Errata** The ADS product may contain references to "HP" or "HPEESOF" such as in file names and directory names. The business entity formerly known as "HP EEsof" is now part of Agilent Technologies and is known as "Agilent EEsof". To avoid broken functionality and to maintain backward compatibility for our customers, we did not change all the names and labels that contain "HP" or "HPEESOF" references.

**Warranty** The material contained in this document is provided "as is", and is subject to being changed, without notice, in future editions. Further, to the maximum extent permitted by applicable law, Agilent disclaims all warranties, either express or implied, with regard to this manual and any information contained herein, including but not limited to the implied warranties of merchantability and fitness for a particular purpose. Agilent shall not be liable for errors or for incidental or consequential damages in connection with the furnishing, use, or performance of this document or of any information contained herein. Should Agilent and the user have a separate written agreement with warranty terms covering the material in this document that conflict with these terms, the warranty terms in the separate agreement shall control.

**Technology Licenses** The hardware and/or software described in this document are furnished under a license and may be used or copied only in accordance with the terms of such license. Portions of this product include the SystemC software licensed under Open Source terms, which are available for download at <http://systemc.org/>. This software is redistributed by Agilent. The Contributors of the SystemC software provide this software "as is" and offer no warranty of any kind, express or implied, including without limitation warranties or conditions or title and non-infringement, and implied warranties or conditions merchantability and fitness for a particular purpose. Contributors shall not be liable for any damages of any kind including without limitation direct, indirect, special, incidental and consequential damages, such as lost profits. Any provisions that differ from this disclaimer are offered by Agilent only.

**Restricted Rights Legend** If software is for use in the performance of a U.S. Government prime contract or subcontract, Software is delivered and licensed as "Commercial computer software" as defined in DFAR 252.227-7014 (June 1995), or as a "commercial item" as defined in FAR 2.101(a) or as "Restricted computer software" as defined in FAR 52.227-19 (June 1987) or any equivalent agency regulation or contract clause. Use, duplication or disclosure of Software is subject to Agilent Technologies' standard commercial license terms, and non-DOD Departments and Agencies of the U.S. Government will receive no greater than Restricted Rights as defined in FAR 52.227-19(c)(1-2) (June 1987). U.S. Government users will receive no greater than Limited Rights as defined in FAR 52.227-14 (June 1987) or DFAR 252.227-7015 (b)(2) (November 1995), as applicable in any technical data.

## Contents

- muRata Manufacturing Measurement-Based SMT Library
  - Schematic Design
    - muRata Manufacturing Measurement-Based
- muRata Manufacturing Measurement-Based SMT Capacitors
  - muRata Manufacturing Measurement-Based GRH Capacitors
    - - Model
      - - muRata Manufacturing Measurement-Based GRH Capacitors Equivalent Circuit Model Schematic Design
      - Data
  - muRata Manufacturing Measurement-Based GRM Capacitors
    - - Model
      - - muRata Manufacturing Measurement-Based GRM Capacitors Equivalent Circuit Model Schematic Design
      - Data
- muRata Manufacturing Measurement-Based SMT Inductors
  - muRata Manufacturing Measurement-Based LQG, LQP and LQN Series Inductors Model
  - LQG Series muRata Manufacturing Measurement-Based Inductors
    - - Schematic Design and Model
    - Data
  - LQN Series muRata Manufacturing Measurement-Based Inductors
    - - Schematic Design and Model
    - Data
  - LQP Series muRata Manufacturing Measurement-Based Inductors
    - - Schematic Design and Model
    - Data

## muRata Manufacturing Measurement-Based SMT Library

The muRata Manufacturing Measurement-Based SMT Library contains the following types of nonlinear models:

- [muRata Manufacturing Measurement-Based SMT Capacitors](#)
- [muRata Manufacturing Measurement-Based SMT Inductors](#)

The muRata Manufacturing Measurement-Based SMT Library consists of discrete-value linear models representing 211 surface mount capacitors and 114 surface mount inductors. The models were extracted from data provided by muRata.



### Note

The library itself is a binary file named mbMrtLibrary.library which can be found in \$HPEESOF\_DIR/ComponentLibs/models.

## Schematic Design

This section describes the schematic design of the muRata manufacturing measurement-based library components and specifies the simulation models that are incorporated in the design.

[muRata Manufacturing Measurement-Based SMT Capacitor Component Example](#) shows an example of how a measurement-based muRata library SMT capacitor component appears when placed into the Schematic design window. The annotation consists of the component name, the default component ID prefix (in this case, C), and the component parameter, PART\_NUM.

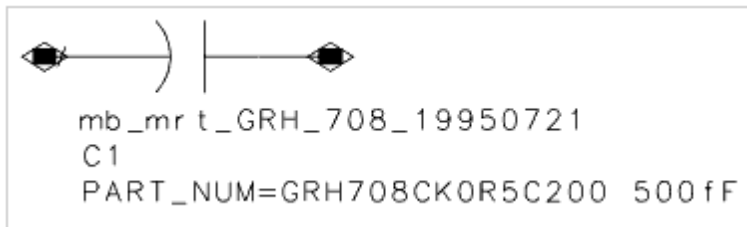

muRata Manufacturing Measurement-Based

### SMT Capacitor Component Example

Each library component represents a series of discrete parts with a common case style. The PART\_NUM parameter is used to identify a specific discrete part in the selected component. In the Component Parameter dialog box, the Parameter Entry Mode option button for the PART\_NUM parameter contains discrete part attributable to the selected component. This option button also includes options for the Discrete Value Optimization and assignment to a specified Variable.

**Important**  
In the Variable Part Index assignment, you assign the index number (not the nominal value) to the PART\_NUM parameter.

For example, [Discrete Value Optimization Variables](#) lists the Parameter Entry Mode options (representing 37 parts ranging from 0.5pF-100pF) for the mb\_mrt\_GRH\_708\_19950721 component PART\_NUM parameter.

Parameter Entry Mode	Nominal Value	Parameter Entry Mode	Nominal Value
Discrete optimize	(does not apply)	Variable Part Index	(does not apply)
GRH708CK0R5C200	0.5	GRH708CH200J200	20
GRH708CKR75C200	0.75	GRH708CH220J200	22
GRH708CK010C200	1.0	GRH708CH240J200	24
GRH708CK1R5C200	1.5	GRH708CH270J200	27
GRH708CK020C200	2.0	GRH708CH300J200	30

## Advanced Design System 2008

GRH708CJ030C200	3.0	GRH708CH330J200	33
GRH708CH040C200	4.0	GRH708CH360J200	36
GRH708CH050C200	5.0	GRH708CH390J100	39
GRH708CH060C200	6.0	GRH708CH430J100	43
GRH708CH070C200	7.0	GRH708CH470J100	47
GRH708CH080C200	8.0	GRH708CH510J100	51
GRH708CH090C200	9.0	GRH708CH560J100	56
GRH708CH100D200	10	GRH708CH620J100	62
GRH708CH110J200	11	GRH708CH680J100	68
GRH708CH120J200	12	GRH708CH750J50	75
GRH708CH130J200	13	GRH708CH820J50	82
GRH708CH150J200	15	GRH708CH910J50	91
GRH708CH160J200	16	GRH708CH101J50	100
GRH708CH180J200	18		

The label field appearing at the top of the Component Parameter dialog box contains the selected component label.

The measurement-based muRata library component represents an equivalent circuit model embedded within the netlist of the schematic design. Several physical models, described in detail in the following subsections, have been implemented in this library for different series.

Unlike the passive SMT component libraries, the measurement-based libraries do not allow the option of choosing different footprint dimensions, since the measurements are board-dependent.

Statistical Yield Analysis is not available through this library.

For discussions on specific models, refer to:

- [muRata Manufacturing Measurement-Based GRH Capacitors](#)
- [muRata Manufacturing Measurement-Based GRM Capacitors](#)

## muRata Manufacturing Measurement-Based SMT Capacitors

The muRata Manufacturing Measurement-Based SMT Capacitor Library groups available for selection from the Schematic and Layout windows are:

- [muRata Manufacturing Measurement-Based GRH Capacitors](#)
- [muRata Manufacturing Measurement-Based GRM Capacitors](#)

For a discussion on the schematic design of the muRata manufacturing measurement-based library components, refer to [Schematic Design](#).

## muRata Manufacturing Measurement-Based GRH Capacitors

### Model

[muRata Manufacturing Measurement-Based GRH Capacitors Equivalent Circuit Model Schematic Design](#) shows the equivalent circuit model schematic design of the muRata Manufacturing Measurement-based GRH series SMT capacitors that is based on device measurements and modeling performed by muRata.

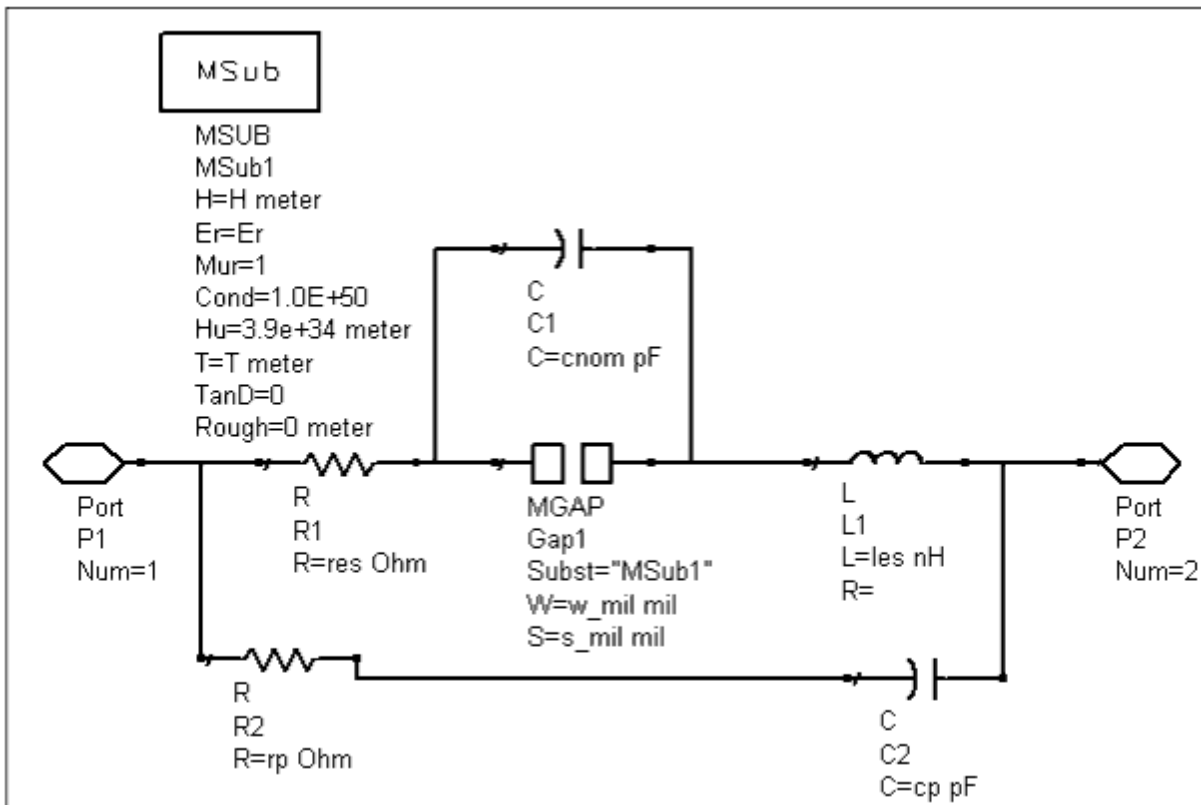

## Advanced Design System 2008

muRata Manufacturing Measurement-Based GRH Capacitors Equivalent Circuit Model Schematic Design

The model used for the muRata Manufacturing Measurement-based GRH Series SMT capacitors has been supplied by muRata. This data is based on the capacitors being mounted on a FR4 substrate material. The substrate parameters are constant for all the discrete parts in this component. The FR4 Substrate Parameters are:

Substrate Thickness = 60 mils  
Relative Dielectric Constant = 4.43  
Relative permeability = 1  
Conductor conductivity = 1.0E+306  
Cover height = 1.0E+308 meter  
Metal thickness = 0 meter  
Dielectric Loss Tangent = 0  
Conductor Surface roughness = 0 meter  
Width of the conductor = 50 mils  
Length of the gap = 30 mils

The values of the equivalent circuit components for the GRH model are extracted from \$HPEESOF\_DIR/ComponentLibs/models/mbMrt.library. This model is verified up to 6 GHz.

The equivalent circuit component values are described below:

Cnom: Nominal capacitance, in pF  
Rp: Insulation resistance, in Ohm  
Cp: Parallel capacitance causing parallel resonance, in pF  
Res: Series resistance, in Ohm  
Les: Series inductance causing series resonance, in nH  
W: Width of the conductor, in mils  
S: Length of the gap, in mils

### Data

The muRata Manufacturing Measurement-based GRH series SMT capacitors are based on highly accurate models verified up to the first two self-resonant frequencies for each device. Applications of the GRH708 series include cellular phones, GPS and RF LAN.

The muRata Manufacturing Measurement-based GRH series SMT capacitors includes 1 component representing a single case style. The naming convention for this component is mb\_mrt\_GRH<case style><extraction date> .

where:

Thermal coefficient = COG (0 ±30 ppm/°C thermal coefficient over the temperature range of -55 to 125°C)  
Case dimensions (length × width) = (708) 0.080 inches × 0.050 inches

The schematic design model for the muRata Manufacturing Measurement-based GRH series SMT capacitors is given by the muRata Manufacturing Measurement-based GRH capacitor model.

Component Name	Description
mb_mrt_GRH_708_19950721	muRata Manufacturing GRH Series, 708 Case, 37 Parts: 0.5pF-100pF

## muRata Manufacturing Measurement-Based GRM Capacitors

### Model

[muRata Manufacturing Measurement-Based GRM Capacitors Equivalent Circuit Model Schematic Design](#) shows the equivalent circuit model schematic design of the muRata Manufacturing Measurement-based GRM series SMT capacitors that is based on device measurements and modeling performed by muRata.

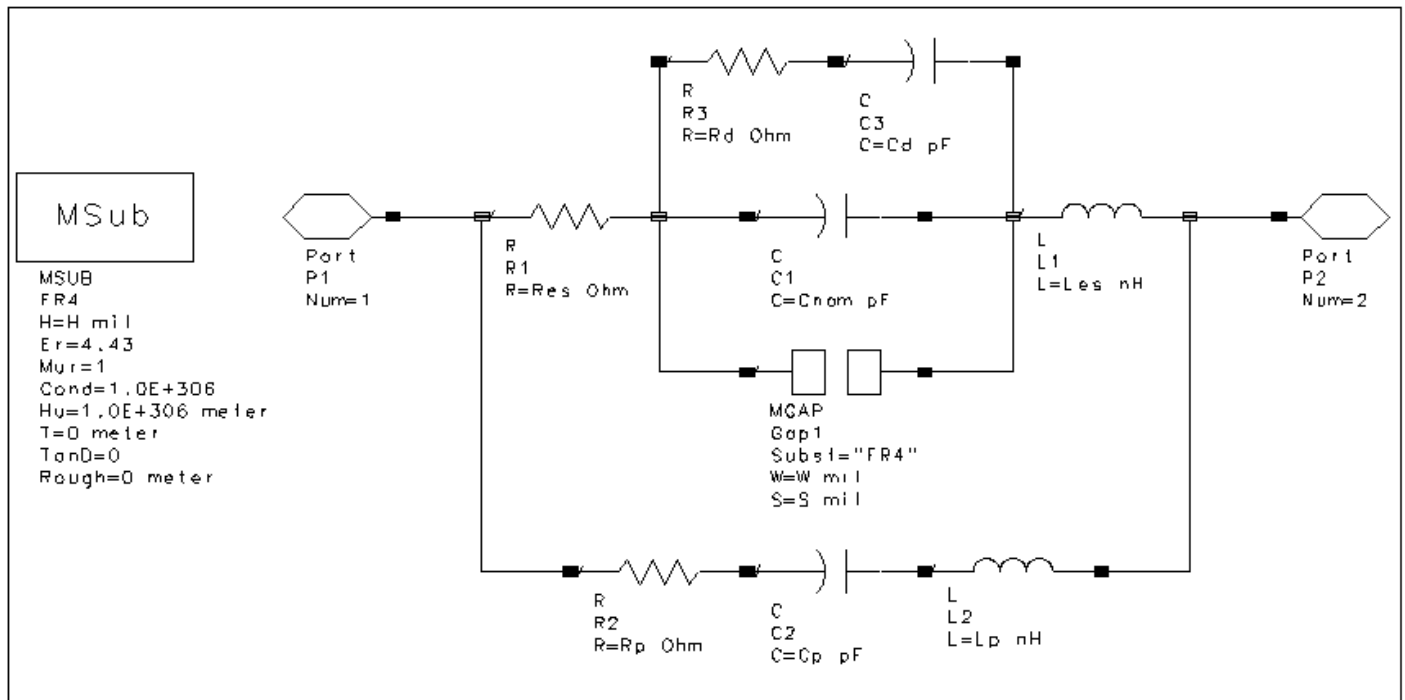

muRata Manufacturing Measurement-Based GRM Capacitors Equivalent Circuit Model Schematic Design

## Advanced Design System 2008

The model used for the muRata Manufacturing Measurement-based GRM series SMT capacitors has been supplied muRata. This data is based on the capacitors being mounted on a FR4 substrate material. The substrate parameters are constant for all the discrete parts in this component. The FR4 Substrate Parameters are:

Substrate Thickness (for case sizes 36 and 39) = 30 mils  
Substrate Thickness (for case size 40) = 60 mils  
Relative Dielectric Constant = 4.43  
Relative permeability = 1  
Conductor conductivity = 1.0E+306  
Cover height = 1.0E+308 meter  
Metal thickness = 0 meter  
Dielectric Loss Tangent = 0  
Conductor Surface roughness = 0 meter  
Width of the conductor (for case sizes 36 and 39) = 34.5 mils  
Width of the conductor (for case size 40) = 50 mils  
Length of the gap (for case sizes 36 and 39) = 19.5 mils  
Length of the gap (for case size 40) = 30 mils

The values of the equivalent circuit components for the GRH model are extracted from \$HPEESOF\_DIR/ComponentLibs/models/mbMrt.library. This model is verified up to 6 GHz.

The equivalent circuit component values are described below:

Cnom: Nominal capacitance, in pF  
Rp: Insulation resistance, in Ohm  
Cp: Parallel capacitance causing parallel resonance, in pF  
Lp: Parallel inductance causing parallel resonance, in nH  
Res: Series resistance, in Ohm  
Les: Series inductance causing series resonance, in nH  
Rd: Second-order parallel resistance, in Ohm  
Cp: Second-order parallel capacitance providing higher-order resonance, in pF  
W: Width of the conductor, in mil  
S: Length of the gap, in mil

### Data

The muRata Manufacturing Measurement-Based GRM Series SMT capacitors are based on highly accurate models verified up to the first two self resonant frequencies for each device.

The muRata Manufacturing Measurement-based GRM series SMT capacitors are used in pagers, cellular radio, and base stations.

The muRata Manufacturing Measurement-Based GRM Series SMT capacitors include 3 components, representing 3

case styles. The naming convention for these components is mb\_mrt\_GRM<case style><extraction date> .

where:

case style = 36, 39 or 40

case dimensions (length × width) are:

36: 0.040 inches × 0.020 inches

39: 0.060 inches × 0.030 inches

40: 0.080 inches × 0.050 inches

The schematic design model for the muRata Manufacturing Measurement-based GRM series SMT capacitors is given by the muRata Manufacturing Measurement-based GRM capacitor model.

Component Name	Description
mb_mrt_GRM_36_19950721	muRata Manufacturing GRM Series, 36 Case, 58 Parts: 0.5pF-10nF
mb_mrt_GRM_39_19950721	muRata Manufacturing GRM Series, 39 Case, 58 Parts: 0.5pF-10nF
mb_mrt_GRM_40_19950721	muRata Manufacturing GRM Series, 40 Case, 58 Parts: 0.5pF-10nF

## muRata Manufacturing Measurement-Based SMT Inductors

- [LQG Series muRata Manufacturing Measurement-Based Inductors](#)
- [LQN Series muRata Manufacturing Measurement-Based Inductors](#)
- [LQP Series muRata Manufacturing Measurement-Based Inductors](#)

For a discussion on the schematic design of the muRata manufacturing measurement-based library components, refer to [Schematic Design](#).

## muRata Manufacturing Measurement-Based LQG, LQP and LQN Series Inductors Model

The model design and measurement and model data for these inductors has been derived by muRata. LQG and LQN series have a unique equivalent circuit model for each case size and the LQP series has the same equivalent circuit model for both case sizes.

## LQG Series muRata Manufacturing Measurement-Based Inductors

### Schematic Design and Model

For a discussion on the schematic design of the muRata manufacturing measurement-based library components, refer to [Schematic Design](#).

For a discussion on the LQG Series model, refer to [muRata Manufacturing Measurement-Based LQG, LQP and LQN Series Inductors Model](#).

### Data

The muRata Manufacturing Measurement-Based LQG Series SMT inductors are based on highly accurate models verified within the frequency range specified in [Frequency Range for Each Discrete Component of muRata Manufacturing Measurement-Based LQG Series 11A Case Style](#) for each device for the case style 11A. The frequency range for all the values of the case style 21N is 1.0MHz to 1.0GHz. The muRata Manufacturing Measurement-based LQG series SMT inductors are used in pagers, cellular radio, and wireless communication equipment.

Part Number	Minimum Frequency	Maximum Frequency	Part Number	Minimum Frequency	Maximum Frequency
LQG11A1N2S00	10 MHz	6.0 GHz	LQG11A10NJ00	10 MHz	4.5 GHz
LQG11A1N5S00	10 MHz	6.0 GHz	LQG11A12NJ00	10 MHz	4.1 GHz
LQG11A1N8S00	10 MHz	6.0 GHz	LQG11A15NJ00	10MHz	3.7 GHz
LQG11A2N2S00	10 MHz	6.0 GHz	LQG11A18NJ00	10 MHz	3.4 GHz
LQG11A2N7S00	10 MHz	6.0 GHz	LQG11A22NJ00	10 MHz	3.1 GHz
LQG11A3N3S00	10 MHz	6.0 GHz	LQG11A27NJ00	10 MHz	2.7 GHz
LQG11A3N9S00	10 MHz	6.0 GHz	LQG11A33NJ00	10 MHz	2.4 GHz
LQG11A4N7S00	10 MHz	6.0 GHz	LQG11A39NJ00	10 MHz	2.3 GHz
LQG11A5N6S00	10 MHz	6.0 GHz	LQG11A47NJ00	10 MHz	2.2 GHz
LQG11A6N8J00	10 MHz	6.0 GHz	LQG11A56NJ00	10 MHz	2.1 GHz
LQG11A8N2J00	10 MHz	5.5 GHz	LQG11A68NJ00	10 MHz	1.7 GHz

The muRata Manufacturing Measurement-Based LQG Series SMT inductors include 2 components, representing 2 case styles. The naming convention for these components is mb\_mrt\_LQG<case style><extraction date> .

where:

case style = 11A or 21N

case dimensions (length × width) are:

11A: 0.063 inches × 0.031 inches

21N: 0.070 inches × 0.049 inches

The equivalent circuit model for the muRata Manufacturing Measurement-based LQG series SMT inductors are given by the muRata Manufacturing Measurement-based LQG11A and LQG21N inductor models.

Component Name	Description
mb_mrt_LQG_11A_19970328	muRata Manufacturing GRH Series, 708 Case, 37 Parts: 0.5pF-100pF
mb_mrt_LQG_21N_19970429	muRata Manufacturing GRM Series, 36 Case, 58 Parts: 0.5pF-10nF

## LQN Series muRata Manufacturing Measurement-Based Inductors

### Schematic Design and Model

For a discussion on the schematic design of the muRata manufacturing measurement-based library components, refer to [Schematic Design](#).

For a discussion on the LQG Series model, refer to [muRata Manufacturing Measurement-Based LQG, LQP and LQN Series Inductors Model](#).

### Data

The muRata Manufacturing Measurement-Based LQN Series SMT inductors are based on highly accurate models verified within the frequency range specified in [Frequency Range for Each Discrete Component of muRata Manufacturing Measurement-Based LQN Series 21A Case Style](#) and [Frequency Range for Each Discrete Component of muRata Manufacturing Measurement-Based LQN Series 21A Case Style](#) for each Discrete Component Value. The muRata Manufacturing Measurement-based LQN series 1H case style SMT inductors are used in mobile communication equipment, FM radio tuners, TV tuners and VIF circuits whereas the high Q value at high frequencies and high self-resonant frequencies make the 21A case style SMT inductors suitable for use in high frequency circuits of communications equipment.

Part Number	Minimum Frequency	Maximum Frequency	Part Number	Minimum Frequency	Maximum Frequency
-------------	-------------------	-------------------	-------------	-------------------	-------------------

## Advanced Design System 2008

LQN1H54NK04	1.0 MHz	1.8 GHz	LQN1HR39K04	1.0 MHz	1.0 GHz
LQN1H95NK04	1.0 MHz	1.5 GHz	LQN1HR50K04	1.0 MHz	1.0 GHz
LQN1HR14K04	1.0 MHz	1.2 GHz	LQN1HR61K04	1.0 MHz	1.0 GHz
LQN1HR21K04	1.0 MHz	1.0 GHz	LQN1HR75K04	1.0 MHz	1.0 GHz
LQN1HR29K04	1.0 MHz	1.0 GHz	LQN1HR88K04	1.0 MHz	1.0 GHz
Part Number	Minimum Frequency	Maximum Frequency	Part Number	Minimum Frequency	Maximum Frequency
LQN21A3N3D04	10 MHz	6.0 GHz	LQN21A39NJ04	10 MHz	2.4 GHz
LQN21A6N8D04	10 MHz	6.0 GHz	LQN21A47NJ04	10 MHz	2.2 GHz
LQN21A8N2D04	10 MHz	5.3 GHz	LQN21A56NJ04	10 MHz	2.0 GHz
LQN21A10NJ04	10 MHz	4.2GHz	LQN21A68NJ04	10 MHz	1.7 GHz
LQN21A12NJ04	10 MHz	3.8 GHz	LQN21A82NJ04	10 MHz	1.6 GHz
LQN21A15NJ04	10 MHz	3.5 GHz	LQN21AR10J04	10 MHz	1.5 GHz
LQN21A18NJ04	10 MHz	3.3 GHz	LQN21AR12J04	10 MHz	1.5 GHz
LQN21A22NJ04	10 MHz	3.0 GHz	LQN21AR15J04	10 MHz	1.5 GHz
LQN21A27NJ04	10 MHz	2.9 GHz	LQN21AR18J04	10 MHz	1.3 GHz
LQN21A33NJ04	10 MHz	2.4 GHz	LQN21AR22J04	10 MHz	1.2 GHz

The muRata Manufacturing Measurement-Based LQN Series SMT inductors include 2 components, representing 2 case styles. The naming convention for these components is mb\_mrt\_LQN<case style><extraction date> .

where:

case style = 1H or 21A

case dimensions (length × width) are:

1H: 0.126 inches × 0.063 inches

21A: 0.079 inches × 0.059 inches

The equivalent circuit model for the muRata Manufacturing Measurement-based LQN series SMT inductors are given by the muRata Manufacturing Measurement-based LQN1H and LQN21A inductor models.

Component Name	Description
mb_mrt_LQN_1H_19970429	muRata Manufacturing GRM Series, 39 Case, 58 Parts: 0.5pF-10nF
mb_mrt_LQN_21A_19970328	muRata Manufacturing GRM Series, 40 Case, 58 Parts: 0.5pF-10nF

## LQP Series muRata Manufacturing Measurement-Based Inductors

### Schematic Design and Model

For a discussion on the schematic design of the muRata manufacturing measurement-based library components, refer to [Schematic Design](#).

For a discussion on the LQG Series model, refer to [muRata Manufacturing Measurement-Based LQG, LQP and LQN Series Inductors Model](#).

### Data

The muRata Manufacturing Measurement-Based LQP Series SMT inductors are based on highly accurate models verified within the frequency range specified in [Tables 3-6](#) and [Frequency Range for Each Discrete Component of muRata Manufacturing Measurement-Based LQP Series 21A Case Style](#) for each Discrete Component Value. The muRata Manufacturing Measurement-based LQP series SMT inductors are used in pagers, cellular radio, and wireless communication equipment.

Part Number	Minimum Frequency	Maximum Frequency	Part Number	Minimum Frequency	Maximum Frequency
LQP11A1N3C00	10 MHz	6.0 GHz	LQP11A6N8C00	10 MHz	5.5 GHz
LQP11A1N5C00	10 MHz	6.0 GHz	LQP11A8N2C00	10 MHz	5.0 GHz
LQP11A1N8C00	10 MHz	6.0 GHz	LQP11A10NG00	10 MHz	4.6 GHz
LQP11A2N2C00	10 MHz	6.0 GHz	LQP11A12NG00	10 MHz	4.0 GHz
LQP11A2N7C00	10 MHz	6.0 GHz	LQP11A15NG00	10 MHz	3.6 GHz
LQP11A3N3C00	10 MHz	6.0 GHz	LQP11A18NG00	10 MHz	3.3 GHz
LQP11A3N9C00	10 MHz	6.0 GHz	LQP11A22NG00	10 MHz	3.0 GHz
LQP11A4N7C00	10 MHz	6.0 GHz	LQP11A27NG00	10 MHz	2.8 GHz
LQP11A5N6C00	10 MHz	6.0 GHz	LQP11A33NG00	10 MHz	2.5 GHz
Part Number	Minimum Frequency	Maximum Frequency	Part Number	Minimum Frequency	Maximum Frequency
LQP21A1N5C14	10 MHz	6.0 GHz	LQP21A15NG14	10 MHz	3.1 GHz
LQP21A1N8C14	10 MHz	6.0 GHz	LQP21A18NG14	10 MHz	2.8 GHz
LQP21A2N2C14	10 MHz	6.0 GHz	LQP21A22NG14	10 MHz	2.5 GHz

## Advanced Design System 2008

LQP21A2N7C14	10 MHz	6.0 GHz	LQP21A27NG14	10 MHz	2.3 GHz
LQP21A3N3C14	10 MHz	6.0 GHz	LQP21A33NG14	10 MHz	2.1 GHz
LQP21A3N9C14	10 MHz	6.0 GHz	LQP21A39NG14	10 MHz	1.9 GHz
LQP21A4N7C14	10 MHz	6.0 GHz	LQP21A47NG14	10 MHz	1.8 GHz
LQP21A5N6C14	10 MHz	6.0 GHz	LQP21A56NG14	10 MHz	1.8 GHz
LQP21A6N8C14	10 MHz	5.2 GHz	LQP21A68NG14	10 MHz	1.6 GHz
LQP21A8N2C14	10 MHz	4.5 GHz	LQP21A82NG14	10 MHz	1.6GHz
LQP21A10NG14	10 MHz	3.9 GHz	LQP21AR10G14	10 MHz	1.5 GHz
LQP21A12NG14	10 MHz	3.5 GHz			

The muRata Manufacturing Measurement-Based LQP Series SMT inductors include 2 components, representing 2 case styles. The naming convention for these components is mb\_mrt\_LQP<case style><extraction date> .

where:

case style = 11A or 21A

case dimensions (length × width) are:

11A: 0.063 inches × 0.031 inches

21A: 0.079 inches × 0.049 inches

The equivalent circuit model for the muRata Manufacturing Measurement-based LQP series SMT inductors is given by the muRata Manufacturing Measurement-based LQP inductor model.

Component Name	Description
mb_mrt_LQP_11A_19970328	muRata Manufacturing LQG Series, 11A Case, 22 Parts: 1.2nH-68nH
mb_mrt_LQP_21A_19970328	muRata Manufacturing LQG Series, 21N Case, 21 Parts: 100nH-4.7uH