



Agilent Technologies

ADS 2008
January 2008
Verilog-A Reference Manual

Advanced Design System 2008

© Agilent Technologies, Inc. 2000-2008

395 Page Mill Road, Palo Alto, CA 94304 U.S.A.

No part of this manual may be reproduced in any form or by any means (including electronic storage and retrieval or translation into a foreign language) without prior agreement and written consent from Agilent Technologies, Inc. as governed by United States and international copyright laws.

Acknowledgments

Mentor Graphics is a trademark of Mentor Graphics Corporation in the U.S. and other countries. Microsoft®, Windows®, MS Windows®, Windows NT®, and MS-DOS® are U.S. registered trademarks of Microsoft Corporation. Pentium® is a U.S. registered trademark of Intel Corporation. PostScript® and Acrobat® are trademarks of Adobe Systems Incorporated. UNIX® is a registered trademark of the Open Group. Java™ is a U.S. trademark of Sun Microsystems, Inc. SystemC® is a registered trademark of Open SystemC Initiative, Inc. in the United States and other countries and is used with permission. MATLAB® is a U.S. registered trademark of The Math Works, Inc.. HiSIM2 source code, and all copyrights, trade secrets or other intellectual property rights in and to the source code in its entirety, is owned by Hiroshima University and STARC.

Errata The ADS product may contain references to "HP" or "HPEESOF" such as in file names and directory names. The business entity formerly known as "HP EEsof" is now part of Agilent Technologies and is known as "Agilent EEsof". To avoid broken functionality and to maintain backward compatibility for our customers, we did not change all the names and labels that contain "HP" or "HPEESOF" references.

Warranty The material contained in this document is provided "as is", and is subject to being changed, without notice, in future editions. Further, to the maximum extent permitted by applicable law, Agilent disclaims all warranties, either express or implied, with regard to this manual and any information contained herein, including but not limited to the implied warranties of merchantability and fitness for a particular purpose. Agilent shall not be liable for errors or for incidental or consequential damages in connection with the furnishing, use, or performance of this document or of any information contained herein. Should Agilent and the user have a separate written agreement with warranty terms covering the material in this document that conflict with these terms, the warranty terms in the separate agreement shall control.

Technology Licenses The hardware and/or software described in this document are furnished under a license and may be used or copied only in accordance with the terms of such license. Portions of this product include the SystemC software licensed under Open Source terms, which are available for download at <http://systemc.org/>. This software is redistributed by Agilent. The Contributors of the SystemC software provide this software "as is" and offer no warranty of any kind, express or implied, including without limitation warranties or conditions or title and non-infringement, and implied warranties or conditions merchantability and fitness for a particular purpose. Contributors shall not be liable for any damages of any kind including without limitation direct, indirect, special, incidental and consequential damages, such as lost profits. Any provisions that differ from this disclaimer are offered by Agilent only.

Restricted Rights Legend If software is for use in the performance of a U.S. Government prime contract or subcontract, Software is delivered and licensed as "Commercial computer software" as defined in DFAR 252.227-7014 (June 1995), or as a "commercial item" as defined in FAR 2.101(a) or as "Restricted computer software" as defined in FAR 52.227-19 (June 1987) or any equivalent agency regulation or contract clause. Use, duplication or disclosure of Software is subject to Agilent Technologies' standard commercial license terms, and non-DOD Departments and Agencies of the U.S. Government will receive no greater than Restricted Rights as defined in FAR 52.227-19(c)(1-2) (June 1987). U.S. Government users will receive no greater than Limited Rights as defined in FAR 52.227-14 (June 1987) or DFAR 252.227-7015 (b)(2) (November 1995), as applicable in any technical data.

Contents

- Overview and Benefits
- - Analog Modeling
 - Hardware Description Languages
 - Verilog-A
 - Compact Models
 - Simulation
 - - Kirchoff's Current and Voltage Laws
 - - Newton-Raphson Algorithm where r is the root
- Verilog-A and Verilog-AMS Modules
- - Declaring Modules
 - - Module Instantiation
 - Syntax
 - Example
 - Ports
 - - Examples
 - Describing Analog Behavior
 - - Syntax
 - - Examples
 - Branches
 - - Syntax
 - Analog Signals
 - - Accessing Net and Branch Signals
 - Examples
 - Indirect branch assignment
 - Branch Contribution Statement
 - User-Defined Analog Functions
 - - Example
 - Hierarchical Structures
 - - Syntax
 - - Examples
 - Module Instance Parameter Value Assignment
 - By Order
 - Example
 - By Name
 - Example
 - Port Assignment
 - By Order
 - Example
 - Scope
- Lexical Conventions
- - White Space
 - Comments
 - Operators
 - Strings
 - - Example
 - Numbers

- - Integer Numbers
 - - Examples
- Real Numbers
 - - Examples
- Scale Factors
 - - Examples
- Keywords
- Identifiers
 - - Examples
- System Tasks and Functions
 - - Examples
- Compiler Directives
- Data Types
- ◦ Integer
 - - Example
- Real
 - - Example
- Type Conversion
- Net Discipline
- Ground Declaration
 - - Syntax
 - Example
- Implicit Nets
 - - Example
- Genvar
 - - Example
- Parameters
 - - Examples
- Analog Block Statements
- ◦ Sequential Block
 - - Syntax
 - Example
- Conditional Statement (if-else)
 - - Syntax
 - Example
- Case Statement
 - - Example
- Repeat Statement
 - - Syntax
 - Example
- While Statement
 - - Syntax
 - Example
- For Statement
 - - Syntax
 - Example
- Mathematical Functions and Operators
- ◦ Unary/Binary/Ternary Operators
 - - Arithmetic Operators
 - Relational Operators

- - Examples
- Logical Operators
- Bit-wise Operators
 - Bitwise AND operator
 - Bitwise OR operator
 - Bitwise Exclusive OR operator
 - Bitwise Exclusive NOR operator
 - Bitwise Negation operator
- Shift Operators
 - Example
- Conditional (Ternary) Operator
 - Syntax
 - Example
- Precedence
- Concatenation Operator
 - Example
- Expression Evaluation
- Arithmetic Conversion
 - Examples
- Mathematical Functions
 - - Standard Mathematical Functions
 - - Transcendental Functions
- Statistical Functions
 - - The \$random Function
 - Syntax
 - Example
 - The \$dist_uniform and \$rdist_uniform Functions
 - Syntax
 - Example
 - The \$dist_normal and \$rdist_normal Functions
 - Syntax
 - Example
 - The \$dist_exponential and \$rdist_exponential Functions
 - Syntax
 - Example
 - The \$dist_poisson and \$rdist_poisson Functions
 - Syntax
 - Example
 - The \$dist_chi_square and \$rdist_chi_square Functions
 - Syntax
 - Example
 - The \$dist_t and \$rdist_t Functions
 - Syntax
 - Example
 - The \$dist_erlang and \$rdist_erlang Functions
 - Syntax
 - Example
- Analog Operators and Filters
 - Tolerances
 - Parameters

- - Examples
- Time Derivative Operator
 - - Syntax
 - Example
- Time Integrator Operator
 - - Syntax
 - Example
- Circular Integrator Operator
 - - Syntax
 - Example
- Absolute Delay Operator
 - - Syntax
 - Example
- Transition Filter
 - - Syntax
 - Transition Filter on Pulse Waveform
 - The TransitionFunction Completion after Interruption
- Slew Filter
 - - Syntax
 - Slew Rate Limiting of Slope
- Last Crossing Function
 - - Syntax
- Limited Exponential
 - - Syntax
 - Example
- Laplace Transform Filters
 - - laplace_zp()
 - Syntax
 - laplace_zd()
 - Syntax
 - laplace_np()
 - Syntax
 - laplace_nd()
 - Syntax
- Z-Transform Filters
 - - zi_zp()
 - Syntax
 - zi_zd()
 - Syntax
 - zi_np()
 - Syntax
 - zi_nd()
 - Syntax
- Analog Events
 - Global Events
 - - The initial_step Event
 - Syntax
 - Example
 - The final_step Event
 - Syntax

Advanced Design System 2008

- Example
 - Global Event Return Codes
- Monitored Events
- - The cross Function
 - - Example
 - The timer Function
 - - Syntax
 - Example
- Event or Operator
- - Example
- Event Triggered Statements
- Mixed Signal Behavior Models
- - Introduction to AMS
 - Describing Behavior for Analog and Digital Simulation
 - - Accessing Discrete Nets and Variables from a Continuous Context
 - - Discreet Data Types Accessible from a Continuous Context
 - Accessing X and Z Bits of a Discrete Net in a Continuous Context
 - Accessing Continuous Nets and Variables from a Discrete Context
 - Detecting Discrete Events in a Continuous Context
 - Detecting Continuous Events in a Discrete Context
 - Concurrency (Synchronization)
 - Discipline Resolution
 - Connect Modules
 - - - - Supported Directional Qualifiers for Connect Modules
 - Connect module specification statements
 - Connect module auto-insertion specification statement
 - Discipline resolution connect statement
 - Passing Parameters [Click here to show related information on EEsof Web site!](#)
 - Setting connect_mode
 - Naming Connect Modules
 - Driver-Receiver Segregation
 - Driver Access Functions and Net Resolution
 - - \$driver_count
 - \$driver_state
 - \$driver_strength
 - - Strength Value Mapping
 - driver_update
- Verilog-A and Verilog-AMS, and the Simulator
- - Environment Parameter Functions
 - - The temperature Function
 - - Syntax
 - Example
 - The abstime Function
 - - Syntax
 - Example
 - The realtime Function
 - - Syntax
 - Example
 - The Thermal Voltage Function
 - - Syntax

- Example
 - Controlling Simulator Actions
 - - Bounding the Time Step
 - Syntax
 - Example
 - Announcing Discontinuities
 - Syntax
 - Example
 - Analysis Dependent Functions
 - - Analysis Function
 - Syntax
 - Types of Analyses
 - Analysis Function Return Codes
 - Example
 - AC Stimulus Function
 - Syntax
 - Noise Functions
 - White Noise Function
 - Syntax
 - Example
 - Flicker Noise Function
 - Syntax
 - Example
 - Noise Table Function
 - Syntax
 - Example
- System Tasks and I/O Functions
- - The \$param_given Function
 - Syntax
 - Example
 - The \$table_model Function
 - Syntax
 - Table Model Inputs
 - Table Data Source
 - Example
 - Example
 - Table Control String
 - Table Interpolation Degree
 - Extrapolation Control String
 - Examples
 - File Input/Output Operations
 - The \$fopen Function
 - Syntax
 - The \$fclose Function
 - Syntax
 - The \$fstrobe Function
 - Syntax
 - Example
 - The \$fdisplay Function
 - Syntax

- The \$fwrite Function
 - Syntax
 - Display Output Operations
 - - The \$strobe Function
 - Syntax
 - Examples
 - The \$display Function
 - Syntax
 - Example
 - Format Specification
 - Escape Sequences
 - Format Specifications
 - Format Specifications for Real Numbers
 - Simulator Control Operations
 - - The \$finish Simulator Control Operation
 - Syntax
 - Example
 - The \$stop Simulator Control Operation
 - Syntax
 - Example
- The Verilog-A and Verilog-AMS Preprocessor
 - Defining Macros
 - Including Files
 - Conditional Compilation
 - Predefined Macros
 - Verilog-AMS and Verilog 1364 1995/2001 Directives
 - Unsupported Directives
- Reserved Words in Verilog-A and Verilog-AMS
- Unsupported Elements
 - Unsupported Elements
- Standard Definitions
 - The disciplines.vams File
 - The constants.vams File
 - The compact.vams File
- Condensed Reference
 - Verilog-A Module Template
 - Data Types
 - Analog Operators and Filters
 - Mathematical Functions
 - Transcendental Functions
 - AC Analysis Stimuli
 - Noise Functions
 - Analog Events
 - Timestep Control
 - Input/Output Functions
 - Simulator Environment Functions
 - Module Hierarchy
 - Example

Overview and Benefits

This topic introduces the Verilog-A language and software in terms of its capabilities, benefits, and typical use.

Analog Modeling

Analog modeling enables designers to capture high-level behavioral descriptions of components in a precise set of mathematical terms. The analog module's relation of input to output can be related by the external parameter description and the mathematical relations between the input and output ports.

Analog models give the designer control over the level of abstraction with which to describe the action of the component. This can provide higher levels of complexity to be simulated, allow faster simulation execution speeds, or can hide intellectual property.

An analog model should ideally model the characteristics of the behavior as accurately as possible, with the trade off being model complexity, which is usually manifested by reduced execution speed. For electrical models, besides the port relationship of charges and currents, the developer may need to take thermal behavior, physical layout considerations, environment (substrate, wires) interaction, noise, and light, among other things into consideration. Users prefer that the model be coupled to measurable quantities. This provides reassurance in validating the model, but also provides a means to predict future performance as the component is modified.

Models often have to work with controlling programs besides the traditional simulator. Optimization, statistical, reliability, and synthesis programs may require other information than which the model developer was expecting.

Hardware Description Languages

Hardware description languages (HDLs) were developed as a means to provide varying levels of abstraction to designers. Integrated circuits are too complex for an engineer to create by specifying the individual transistors and wires. HDLs allow the performance to be described at a high level and simulation synthesis programs can then take the language and generate the gate level description.

Verilog and VHDL are the two dominant languages; this manual is concerned with the Verilog language.

As behavior beyond the digital performance was added, a mixed-signal language was created to manage the interaction between digital and analog signals. A subset of this, Verilog-A, was defined. Verilog-A describes analog behavior only; however, it has functionality to interface to some digital behavior.

Verilog-A

Verilog-A provides a high-level language to describe the analog behavior of conservative systems. The disciplines and natures of the Verilog-A language enable designers to reflect the potential and flow descriptions of electrical, mechanical, thermal, and other systems.

Verilog-A is a procedural language, with constructs similar to C and other languages. It provides simple constructs to describe the model behavior to the simulator program. The model effectively de-couples the description of the model from the simulator.

The model creator provides the constitutive relationship of the inputs and outputs, the parameter names and ranges, while the Verilog-A compiler handles the necessary interactions between the model and the simulator. While the language does allow some knowledge of the simulator, most model descriptions should not need to know anything about the type of analysis being run.

Compact Models

Compact models are the set of mathematical equations that describe the performance of a device. Commercial simulators use compact models to describe the performance of semiconductor devices, most typically transistors.

There is a wide range of modeling categories, including neural nets, empirical, physical, and table based. Each has distinct advantages and disadvantages as listed in the following table.

Type	Advantage	Disadvantage
Physical	Predicts performance best Extrapolates	Must understand physics Slow
Empirical	Reasonably good prediction Fast	Can give non-physical behavior
Tabular	Very general Easy to extract Reasonable execution speed	Cannot extrapolate Minimal parameter info
Neural net	Very general Reasonable execution speed	Cannot extrapolate Minimal parameter info

For electrical modeling, most compact device models use empirical modeling based on physical models. This provides the best combination of execution speed, accuracy, and prediction. However, non-physical behavior may result when the equations are used outside their fitting range. Model creators should also be aware of the issues around parameter extraction. If a model's parameters cannot easily or accurately be extracted, the model will not be successful.

Once created, a compact model can be implemented in a simulator in a variety of methods (see the following table). Each method has its own advantages and disadvantages, but in general, the simpler the interface, the less capable it

is.

Type	Advantage	Disadvantage
Macro model	Simple, portable	Limited to available primitives
Proprietary interface	Power, fast	Need access to simulator Not portable
Public interface	Reasonably powerful	Usually missing some capability Not portable Unique complexity Slow
AHDLs (Verilog-A)	Simple Power Portable Protected	Language has some restrictions

The most powerful interface is the proprietary interface to the simulator. For many reasons, most typically intellectual property protection, the proprietary interface is not made public. This is because the interface usually requires such intimate details of the simulator analysis operation that a clever investigator could discern much detail about the inner workings of the simulation algorithms.

On the other hand, a detailed, complex interface also requires a detailed understanding by the model developer to properly access the functionality of the analysis. This can require as much effort as the development of the model itself. If the model is to be added using this interface to other simulators, often the effort of learning one interface does not provide much advantage in learning the nuances of the other.

Simulator vendors often provide simplified interfaces, either a scaled-back code level interface, or a custom symbolic interface. The simplicity always comes at a price of reduced functionality, decreased execution speed, or a lack of portability.

Analog Hardware Description languages (AHDLs) solve most of these problems, except the problem of execution speed. However, compiler technology in Advanced Design System provides the abstraction and simplicity of Verilog-A with an execution speed with a factor of two of code level interfaces.

Simulation

Most analog simulators evolved from the SPICE program released by UC Berkeley. The analog simulator solves a simple set of relations for a large number of unknowns to provide the designer with the voltage and currents at each of the nodes in the circuit as either a function of time or frequency. The electrical relations are simply the Kirchoff current law and voltage loop laws:

- The instantaneous currents from all branches entering a node must sum to zero.

- The instantaneous voltages around any closed loop must sum to zero.

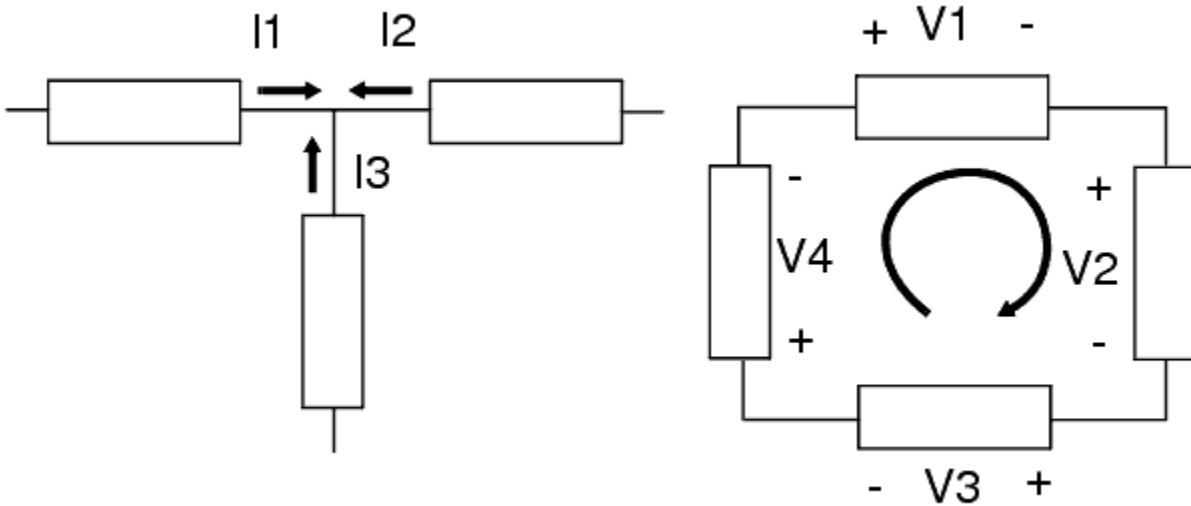

Kirchoff's Current and Voltage Laws

The program solves these equations using an algorithm known as Newton-Raphson. The program guesses a solution to the relation:

$$F(v, t) = 0$$

It next calculates if the solution is close enough, and if it is, it stops. If the program needs to find the next guess, it calculates the Jacobian of the function (the set of partial derivatives), which provides a pointer towards the real solution. This is best seen in a simple case where $F(v,t)$ is one dimensional:

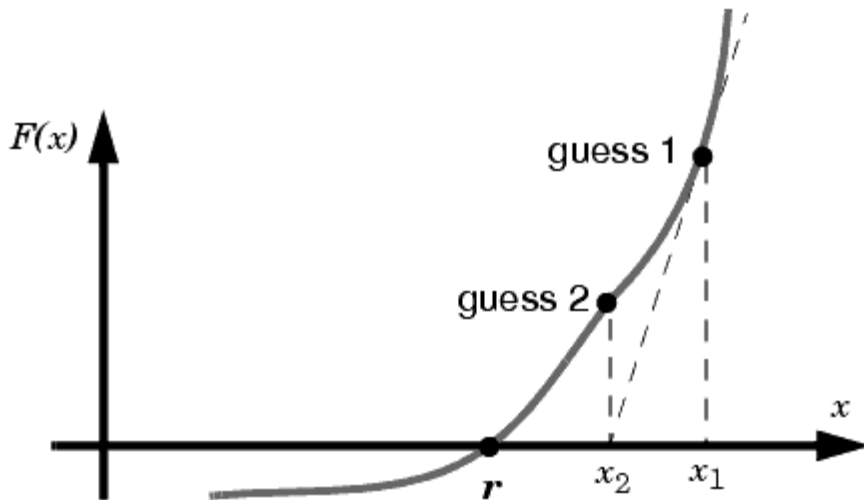

Newton-Raphson Algorithm where r is the root

The program calculates $F(x_1)$ and then uses the derivative (the slope of the line) to estimate the zero-crossing. It then uses this new point, x_2 , as the next guess. As long as the function is continuous and smooth (and the program does not get stuck in local minima), the program will quickly approach, or converge to, the actual point where $F(x)$ crosses zero.

In modern simulation programs the trick is to quickly find the solution for a large number of variables, and for variables that may have strong (nonlinear) relations to independent variables.

During a simulation, the program queries each element in the circuit for information. The resistor, the capacitor, or the transistor, for example, needs to report back to the simulator its behavior at a particular guess. It must also report back its slope with respect to the voltages at that point.

The behavior of each element is described by mathematical equations that, taken as a group, are called a compact device model. The compact device model can be very simple or very complicated. For example, in the simplest case, a resistor can be described by Ohm's law:

$$I = V/R$$

The derivative is a constant, the inverse of the resistance.

However, even for simple components like resistors, the models can become rather complicated when other effects are added, such as, self-heating, self-inductance, thermal noise, etc. The Verilog-A compiler manages all of the necessary interfaces so that, for the most part, the developer need only be concerned with model behavior.

Verilog-A and Verilog-AMS Modules

This topic discusses the concept of Verilog-A modules, showing the basic structure of a module declaration, how to define parameters and ports, and how to define a simple analog block.

Declaring Modules

The module declaration provides the simulator with the name of the module, the input and output ports, parameter information, and the behavioral description of the model. Top-level modules are modules which are included in the source text but are not instantiated. Module definitions cannot contain the text of another module definition. A module definition can nest another module by instantiating it. For more information, refer to [Hierarchical Structures](#).

Module Instantiation

Syntax

```
module | macromodule module_identifier [(port {, port, ...})]
  module_statements
endmodule
```

where *module_identifier* is the name of the module and the optional list of port name(s) defines the connections to the module, and *module_statements* describe the module behavior.

Example

The simplest example is a resistor.

```
`include "disciplines.vams"
module R(p,n);
  electrical p,n;
  parameter real R=50.0;
  analog
    V(p,n) <+ R * I(p,n);
endmodule
```

The first line provides common definitions. The line `module R(p, n) ;` declares the module name to be R and that it has 2 ports, named p and n , which the next line further describes by attributing the electrical discipline to the ports.

This module has one parameter, R , which is declared as a real type with a default value of 50.0. Parameters provide a way to pass information into the module at the time of instantiation.

The analog block, in this example a single line, describes the behavior using a voltage contribution statement to assign the voltage based on the access function value of I() times R.

Ports

Ports provide a way to connect modules to other modules and devices. A port has a direction: input, output, or inout, which must be declared. The ports are listed after the module declaration. The port type and port direction must then be declared in the body of the module.

Examples

```
module resistor(p,n);
  inout p,n;
  electrical p,n;
  ...

module modName(outPort, inPort);
  output outPort;
  input inPort;
  electrical outPort, inPort;
  ...
```

Ports can support vectors (buses) as well.

Describing Analog Behavior

The analog behavior of the component is described with procedural statements defined within an analog block. During simulation, all of the analog blocks are evaluated. Each module is evaluated in the design as though it were contributing concurrently to the analysis.

Syntax

`analog block_statement`

where `block_statement` is a single analog statement of a group of statements.

Examples

```
analog V(n1, n2) <+ 1; // A simple 1 volt source

analog begin // A multi-statement analog block
  vin = V(in);
  if (vin >= signal_in_dead_high)
    vout = vin - signal_in_dead_high;
  else
    if (vin <= signal_in_dead_low)
      vout = vin - signal_in_dead_low;
    else
      vout = 0.0;
  V(out) <+ vout;
end
```

Branches

A branch is defined as a path between two nets. A branch is conservative if both nets are conservative and two associated quantities, potential and flow, are defined for the branch. If either net is a signal-flow net, then the branch is defined as a signal-flow branch with either a potential or flow defined for the branch.

Syntax

`branch list_of_branches`

where `list_of_branches` is a comma-separated list of branch names.

Analog Signals

Analog signals are signals associated with a discipline that has a continuous domain. Their value can be accessed and

set via various functions and contribution statements. This section describes the analog signal functions. It describes how to access signal data from nodes and vectors, as well as how to use the contribution operator.

Accessing Net and Branch Signals

Signals on nets and branches can be accessed only by the access functions of the associated discipline. The name of the net or the branch is specified as the argument to the access function.

Examples

```
Vin = V(in);  
CurrentThruBranch = I( myBranch );
```

Indirect branch assignment

An indirect branch assignment is useful when it is difficult to solve an equation. It has this format,

```
V(n) : V(p) == 0;
```

which can be read as "find $V(n)$ such that $V(p)$ is equal to zero." This example shows that node n should be driven with a voltage source and the voltage should be such that the given equation is satisfied. $V(p)$ is probed and not driven.



Note

Indirect branch assignments are allowed only within the analog block.

Branch Contribution Statement

A branch contribution statement typically consists of a left-hand side and a right-hand side, separated by a branch contribution operator. The right-hand side can be any expression which evaluates to (or can be promoted to) a real value. The left-hand side specifies the source branch signal to assign the right-hand side. It consists of a signal access function applied to a branch. The form is,

```
V(n1, n2) <+ expression;
```

```
I(n1, n2) <+ expression;
```

Branch contribution statements implicitly define source branch relations. The branch extends from the first net of the access function to the second net. If the second net is not specified in the call, the global reference node (`ground`) is used as the reference net.

User-Defined Analog Functions

Analog functions provide a modular way for a user-defined function to accept parameters and return a value. The functions are defined as analog or digital and must be defined within modules blocks.

The analog function is of the form:

```
analog function {real|integer} function_name;  
input_declaration;  
statement_block;  
endfunction
```

The `input_declaration` describes the input parameters to the function as well as any variables used in the statement block:

```
input passed_parameters;  
real parameter_list;
```

The `statement_block` and analog function:

- can use any statements available for conditional execution
- cannot use access functions
- cannot use contribution statements or event control statements
- must have at least one input declared; the block item declaration declares the type of the inputs as well as local variables used
- cannot use named blocks
- can only reference locally-defined variables or passed variable arguments

The analog function implicitly declares a variable of the same name as the function, `function_name`. This variable must be assigned in the statement block; its last assigned value is passed back.

Example

```
analog function real B_of_T;
  input B, T, T_NOM, XTB;
  real B, T, T_NOM, XTB;
  begin
    B_of_T = B * pow(T / T_NOM, XTB);
  end
endfunction
```

The function is called by the line,

```
BF_T = B_of_T(BF, T, T_NOM, XTB);
```

Hierarchical Structures

Verilog-A supports hierarchical descriptions, whereby modules can instantiate other modules. This section describes the procedure for implementing and calling hierarchical models.

Syntax

```
module_or_primitive [#(.param1(expr)[, .param2(expr)])]instance_name ({node {, node}});
```

Examples

```
phaseDetector #(.gain(2)) pd1(lo, rf, if_);
```

```
vco #(.gain(loopGain/2), .fc(fc) ) vcol(out, lo);
```

Module Instance Parameter Value Assignment

The default parameter values can be overridden by assigning them via an ordered list or explicitly when instantiating a module.

By Order

In this method, the assignment order in the instance declaration follows the order of the parameter declaration in the module declaration. It is not necessary to assign all of the parameters, but all parameters to the left of a declaration must be defined (that is, parameters to the left of the last declaration can not be skipped).

Example

```
// Voltage Controlled Oscillator
module vco(in, out);
  inout in, out;
  electrical in, out;
  parameter real gain = 1, fc = 1;
  analog
    V(out) <+ sin(2*`M_PI*(fc*$realtime() + idt(gain*V(in)));
  endmodule
...
// Instantiate a vco module name vco1 connected to out and
// lo with gain = 0.5, fc = 2k
vco #(0.5, 2000.0) vco1(out, lo);
```

By Name

Alternatively, instance parameters can be assigned explicitly by their name, where the name matches the parameter name in the module. In this method, only the parameters that are modified from their default values need to be assigned.

Example

```
// Voltage Controlled Oscillator

module vco(in, out);
  inout in, out;
  electrical in, out;
```

```
parameter real gain = 1, fc = 1;
analog

    V(out) <+ sin(2*`M_PI*(fc*$realtime() + idt(gain*V(in))));

endmodule

...

// Instantiate a vco module name vco1 connected to out and lo with
// gain = loopGain/2, fc = fc

vco #(.gain(loopGain/2), .fc(fc) ) vco1(out, lo);
```

Port Assignment

Ports can be assigned either via an ordered list or directly by name.

By Order

To connect ports by an ordered list, the ports in the instance declaration should be listed in the same order as the module port definition.

Example

```
module sinev(n1,n2);
    electrical n1,n2;
    parameter real gain = 1.0, freq = 1.0;
    analog begin
        V(n2,n1) <+ gain * sin(2 * `M_PI * freq * $abstime);
        $bound_step(0.05/freq);
    end
endmodule
...
// Instantiate a source1 with in->n1, out->n2
sinev #(.gain(G), .freq(F) ) source1(in, out)
```

Scope

Verilog-A supports name spaces for the following elements:

- modules
- tasks
- named blocks
- functions
- analog functions

Within each scope only one identifier can be declared. To reference an identifier directly, the identifier must be declared locally in the named block, or within a module, or within a named block that is higher in the same branch of the name hierarchy that contains the named block. If an identifier is declared locally, it will be used, otherwise the identifier will be searched upwards until it is found, or until a module boundary is reached.

Lexical Conventions

This topic describes the overall lexical conventions of Verilog-A, and how the language defines and interprets various elements such as white space, strings, numbers, and keywords.

Verilog-A consists of lexical tokens (one or more characters) of the form:

- [White Space](#)
- [Comments](#)
- [Operators](#)
- [Strings](#)
- [Numbers](#)
- [Keywords](#)
- [Identifiers](#)
- [System Tasks and Functions](#)
- [Compiler Directives](#)

The source file is free form where spaces, tabs, and newlines are only token separators and have no other significance. Lines can be extended using the line continuation character / where needed.

White Space

White space consists of spaces, tabs, newlines, and form feeds. They separate tokens, otherwise are ignored.

Comments

There are two ways to include comments:

- A single line comment starts with `//` and continues to the end of the line.

Example

```
// This is a single line comment
```

- Block statements begin with `/*` and end with `*/` and cannot be nested but can include single line comments.

Example

```
/* This is a block comment which can  
include any ASCII character  
*/
```

Operators

Verilog-A has unary (single) operators, binary (double) operators and the conditional operator. Unary operators appear to the left of the operand, and binary between their operands. The conditional operator separates the three operands with two special characters.

Strings

Strings are sequences of characters enclosed by double quotes and contained on one line.

Example

```
"This is a string."
```

Numbers

Constant numbers can be specified as integer or a real constants; complex constants are not allowed. Scale factors

can be used for readability on real numbers.

Integer Numbers

Integer constants must be specified as a sequence of the digits 0 through 9 in a decimal format with an optional + or - unary operator at the start. The underscore character can be used at any position except the first character as a means to break up the number for readability.

Examples

12345

-122

867_5309

Real Numbers

Real constants follow the IEEE standard for double precision floating point numbers, IEEE STD-754-1985. They can be specified in decimal notation or scientific notation. If a decimal point is used, the number must have at least one digit on each side of the decimal point (e.g., 0.1 or 17.0 are allowed, .1 or 17. are not). As in the integer case, the underscore character is allowed anywhere but the first character and is ignored.

Examples

3.14

1.23e-9

27E9

876_763_300E10

Scale Factors

Scale factors can be used on floating point numbers, but cannot be used with numbers in scientific format. The scale factor symbol and the number cannot have a space between them.

Scale Factor Symbol	Multiplier
T	10 ¹²
G	10 ⁹
M	10 ⁶
K or k	10 ³
m	10 ⁻³
μ	10 ⁻⁶
n	10 ⁻⁹
p	10 ⁻¹²
f	10 ⁻¹⁵
a	10 ⁻¹⁸

Examples

2.5m	2.5e-3	0.025
0.11M	1.1e5	110000

Keywords

Keywords are predefined non-escaped identifiers. Keywords define the language constructs. They are defined in

lowercase only. [Reserved Words in Verilog-A and Verilog-AMS](#), lists all of the keywords, which includes the Verilog-AMS keywords.

Identifiers

Identifiers give objects unique names for reference and can consist of any sequence of letters, digits, the \$ character, and the _ (underscore) character. The first character of an identifier can be a letter or underscore, it cannot be the \$ character or a digit. Identifiers are case sensitive.

Examples

```
deviceName
```

```
i
```

```
Vth0
```

```
vth0
```

```
_device
```

```
sheet_rho$
```

System Tasks and Functions

User-defined tasks and functions use a \$ character to declare a system task or system function. Any valid identifier, including keywords (not already in use in this construct), can be used as system task and system function names. Note that for backward compatibility with earlier versions of Verilog-A, this implementation reserves some task and function names.

Examples

```
$temperature;  
  
$strobe("hello");
```

Compiler Directives

Compiler directives are indicated using the ` (accent grave) character. For more information, refer to [The Verilog-A and Verilog-AMS Preprocessor](#), for a discussion of compiler directives.

Data Types

This section describes the various data types that Verilog-A supports as well as shows the correct format and use model. Verilog-A supports integer, real, parameter, and discipline data types.

Integer

An integer declaration declares one or more variables of type integer holding values ranging from -2^{31} to $2^{31} - 1$. Arrays of integers can be declared using a range which defines the upper and lower indices of the array where the indices are constant expressions and shall evaluate to a positive or negative integer, or zero.

Example

```
integer flag, MyCount, I[0:63];
```

Real

A real declaration declares one or more variables of type real using IEEE STD-754-1985 (the IEEE standard for double precision floating point numbers). Arrays of reals can be declared using a range which defines the upper and lower indices of the array where the indices are constant expressions and shall evaluate to a positive or negative integer, or zero.

Example

```
real X[1:10], Tox, Xj, Cgs;
```

Type Conversion

Verilog-A maintains the number type during expression evaluation and will also silently convert numbers to the type of the variable. This can lead to unexpected behavior. For example, the contribution statement,

```
I(di,si) <+ white_noise(4 * `P_K * T * (2/3) * abs(gm), "shot");
```

will always return 0 since the $2/3$ term is evaluated using integer mathematics, and no noise is contributed from the noise power expression. Instead, use $2.0/3.0$ which will evaluate to a real number.

Net Discipline

The net discipline is used to declare analog nets. A net is characterized by the discipline that it follows. Because a net is declared as a type of discipline, a discipline can be considered as a user-defined type for declaring a net.

A discipline is a set of one or more nature definitions forming the definition of an analog signal whereas a nature defines the characteristics of the quantities for the simulator. A discipline is characterized by the domain and the attributes defined in the natures for potential and flow.

The discipline can bind:

- One nature with potential
- Nothing with either potential or flow (an empty discipline)

System defined disciplines are predefined in the disciplines.vams file, a portion of which is shown below.

```

// Electrical

// Current in amperes
nature Current
units = "A";
access = I;
idt_nature = Charge;
`ifndef CURRENT_ABSTOL
    abstol = `CURRENT_ABSTOL;
`else
    abstol = 1e-12;
`endif
endnature

// Charge in coulombs
nature Charge
units = "coul";
access = Q;
ddt_nature = Current;
`ifndef CHARGE_ABSTOL
    abstol = `CHARGE_ABSTOL;
`else
    abstol = 1e-14;
`endif
endnature

// Potential in volts
nature Voltage
units = "V";
access = V;
idt_nature = Flux;
`ifndef VOLTAGE_ABSTOL
    abstol = `VOLTAGE_ABSTOL;
`else
    abstol = 1e-6;
`endif
endnature

```

Ground Declaration

A global reference node, or ground, can be associated with an already declared net of continuous discipline.

Syntax

```
ground list_of_nets ;
```

where *list_of_nets* is a comma-separated list of nets.

Example

```
`include "disciplines.vams"
module load(p);
  electrical p, gnd;
  ground gnd;
  parameter real R=50.0;
  analog
    V(p) <+ R * I(p, gnd);
endmodule
```

Implicit Nets

Nets used in a structural description do not have to be explicitly declared. The net is declared implicitly as scalar, the discipline as empty, and the domain as undefined.

Example

```
`include "disciplines.vams"
module Implicit_ex(Input1, Input2, Output1, Output2, Output3);
  input  Input1, Input2;
  output Output1, Output2, Output3;
  electrical Input1, Input2, Output1, Output2, Output3;
  blk_a a1(Input1, a_b1);
  blk_a a2(Input2, a_b2);
  blk_b b1(a_b1, c_b1);
  blk_b b2 (a_b2, c_b2);
  blk_c c1(Output1,Output2, Output3,c_b1,c_b2);
endmodule
```

Genvar

Genvars are used for accessing analog signals within behavioral looping constructs.

```
genvar list_of_genvar_identifiers ;
```

where list_of_genvar_identifiers is a comma-separated list of genvar identifiers.

Example

```
genvar i , j ;
```

Parameters

Parameters provide the method to bring information from the circuit to the model.

Parameter assignments are a comma-separated list of assignments. The right hand side of the assignment is a constant expression (including previously defined parameters).

For parameter arrays, the initializer is a list of constant expressions containing only constant numbers and previously defined parameters within bracket delimiters, {}.

Parameter values cannot be modified at runtime.

```
parameter {real | integer} list_of_assignments ;
```

where the `list_of_assignments` is a comma separated list of

```
parameter_identifier = constant [ value-range ]
```

where `value-range` is of the form

```
from value_range_specifier
| exclude value_range_specifier
| exclude constant_expression
```

where the `value_range_specifier` is of the form

```
start_paren expression1 : expression2 end_paren
```

where `start_paren` is "[" or "(" and `end_paren` is "]" or ")" and `expression1` is `constant_expression` or "-inf " and `expression2` is `constant_expression` or "inf ".

The `type(real | integer)` is optional. If it is not given, it will be derived from the constant assignment value. A parenthesis indicates the range can go up to, but not include the value, whereas a bracket indicates the range includes the endpoint. Value ranges can have simple exclusions as well.

Examples

```
/* Define a parameter of type real with a default value of 0 and allowed
values between 0 and up to, but not including, infinity and excluding values
between 10 and 100 (however, 10 and 100 are acceptable) and 200 and 400 (200
is acceptable, but 400 is not.) */

parameter real TestFlag = 0 from [0:inf) exclude (10:100) exclude (200:400];

/* Define a real parameter with a default value of 27, ranging from -273.15
up to, but not including infinity. */

parameter real Temp = 27 from [-273.15:inf);

/* Define a parameter R with a default value of 50, ranging from, but not
including, 0 to infinity. R is implicitly defined as type integer. */

parameter R = 50 from (0:inf];
```

Analog Block Statements

The analog block is where most of the analog behavior is described. This topic describes the analog block, and discusses the various procedural control statements available in Verilog-A.

Sequential Block

A sequential block is a grouping of two or more statements into one single statement.

Syntax

```
begin [ : block_identifier [ block_item_declaration ]]
{ statement }
end
```

The optional block identifier allows for naming of the block. Named blocks allow local variable declaration.

Example

```
if (Vds < 0.0) begin: RevMode
  real T0; // T0 is visible in this block only
  T0 = Vsb;
  Vsb = Vsb \+ Vds;
  Vdss = - Vds \+ T0;
end
```

Conditional Statement (if-else)

The conditional statement is used to determine whether a statement is executed or not.

Syntax

```
if ( expression ) true_statement ;
[ else false_statement ; ]
```

If the expression evaluates to true (non-zero), then the true_statement will be executed. If there is an else false_statement and the expression evaluates to false (zero), the false_statement is executed instead.

Conditional statements may be nested to any level.

Example

```
if (Vd < 0)
  begin
    if (Vd < -Bv)
      Id = -Area * Is_temp * (limexp(-(Bv + Vd) / Vth) + Bv / Vth);
    else if (Vd == -Bv)
      Id = -Area * Ibv_calc;
    else if (Vd <= -5 * N * Vth)
      Id = -Area * Is_temp;
```

```

else // -5 nKT/q <= Vd < 0
  Id = Area * Is_temp * (limexp(Vd / Vth) - 1);
end
else
  Id = Area * Is_temp * (limexp(Vd / (N * Vth)) - 1);

```

Case Statement

A case statement is useful where multiple actions can be selected based on an expression. The format is:

```
case ( expression ) case_item { case_item } endcase
```

where case_item is:

```
expression { , expression } : statement_or_null
| default [ : ] statement_or_null
```

The default-statement is optional; however, if it is used, it can only be used once. The case expression and the case_item expression can be computed at runtime (neither expression is required to be a constant expression). The case_item expressions are evaluated and compared in the exact order in which they are given. If one of the case_item expressions matches the case expression given in parentheses, then the statement associated with that case_item is executed. If all comparisons fail then the default item statement is executed (if given). Otherwise none of the case_item statements are executed.

Example

```

case(rgeo)
1, 2, 5: begin
  if (nuEnd == 0.0)
    Rend = 0.0;
  else
    Rend = Rsh * DMCG / (Weffcj * nuEnd);
end
3, 4, 6: begin
  if ((DMCG + DMCI) == 0.0)
    $strobe"(DMCG + DMCI) cannot be equal to zero\n");
  if (nuEnd == 0.0)
    Rend = 0.0;
  else
    Rend = Rsh * Weffcj / (3.0 * nuEnd * (DMCG + DMCI));
end

```

```
default:  
    $strobe("Warning: Specified RGeo = %d not matched (BSIM4RdsEndIso)\n", rgeo);  
endcase
```

Repeat Statement

The `repeat()` statement executes a statement a fixed number of times. The number is given by the repeat expression.

Syntax

```
repeat ( expression ) statement
```

Example

```
repeat (devIndex - startIndex) begin  
    devTemp = incrByOne(devTemp, offset);  
end
```

While Statement

`while()` executes a statement until its control expression becomes false. If the expression is false when the loop is entered, the statement is not executed at all.

Syntax

```
while ( expression ) statement
```

Example

```
while(devTemp < T) begin
    devTemp = incrTemp(devTemp, offset);
end
```

For Statement

The `for()` statement controls execution of its associated statement (s) using an index variable. If the associated statement is an analog statement, then the control mechanism must consist of genvar assignments and genvar expressions only. No use of procedural assignments and expressions are allowed.

Syntax

```
for ( procedural_assignment ; expression;
      procedural_assignment ) statement
```

If the `for()` loop contains an analog statement , the format is:

```
for ( genvar_assignment; genvar_expression;
      genvar_assignment ) analog_statement
```

Note that the two are syntactically equivalent except that the executed statement is also an analog statement (with the associated restrictions).

Example

```
for (i = 0; i < maxIndex; i = i +1;) begin
    outReg[i] = getValue(i);
end
```

Mathematical Functions and Operators

Verilog-A supports a range of functions and operators that may be used to form expressions that describe model behavior and to control analog procedural block flow. Return values from these functions are only a function of the current parameter value.

Unary/Binary/Ternary Operators

Arithmetic operators follow conventions close to the C programming language.

Operator	Type
+ - * /	Arithmetic
%	Modulus
> >= < <=	Relational
!= ==	Logical equality
!	Logical negation
&&	Logical and
	Logical or
~	Bit-wise negation
&	Bit-wise and
	Bit-wise inclusive or
^	Bit-wise exclusive or
^~ ~^	Bit-wise equivalence
<<	Left shift
>>	Right shift
?:	Conditional
or	Event or
{ } { { } }	Concatenation, replication

Arithmetic Operators

The arithmetic operators are summarized in the following table.

Operator	Function
$a + b$	a plus b
$a - b$	a minus b
$a * b$	a times b
a / b	a divided by b
$a \% b$	a modulo b

See also [Precedence](#) and [Arithmetic Conversion](#).

Relational Operators

The following table defines and summarizes the relational operators.

Operator	Function
$a < b$	a is less than b
$a > b$	a is greater than b
$a \leq b$	a is less than or equal to b
$a \geq b$	a is greater than or equal to b

The relational operators evaluate to a zero (0) if the relation is false or one (1) if the relation evaluates to true. Arithmetic operations are performed before relational operations.

Examples

```
a = 10;
```

```
b = 0;
```

```
a < b evaluates to false.
```

Logical Operators

Advanced Design System 2008

Logical operators consist of equality operators and connective operators and are summarized in the following table.

Operator	Function
$a == b$	a is equal to b
$a != b$	a is not equal to b
$a \&\& b$	a AND b
$a b$	a OR b
$!a$	not a

Bit-wise Operators

Bit-wise operators perform operations on the individual bits of the operands following the logic described in the tables below.

Bitwise AND operator

$\&$	0	1
0	0	0
1	0	1

Bitwise OR operator

$ $	0	1
0	0	1
1	1	1

Bitwise Exclusive OR operator

\wedge	0	1
0	0	1
1	1	0

Bitwise Exclusive NOR operator

$\wedge\sim$ $\sim\wedge$	0	1
0	1	0

1	0	1
---	---	---

Bitwise Negation operator

	~	
0		1
1		0

Shift Operators

The shift operators shift their left operand either right (>>) or left (<<) by the number of bit positions indicated by their right operand, filling the vacated bit positions with zeros (0). The right operand is treated as an unsigned number.

Example

```
integer mask, new;
analog begin
    mask = 1;
    new = (mask << 4);
end
```

Conditional (Ternary) Operator

The conditional operator consists of three operands, separated by the operators ? (question mark) and : (colon).

Syntax

expression1 ? expression2 : expression3

The expression1 is first evaluated. If it evaluates to false (0) then expression3 is evaluated and becomes the result. If expression1 is true (any non-zero value), then expression2 is evaluated and becomes the result.

Example

```
BSIM3vth0 = (BSIM3type == `NMOS) ? 0.7 : -0.7;
```

Precedence

The following table shows the precedence order of the operators, with operators in the same row having equal precedence. Association is left to right with the exception of the conditional (ternary) operator, which associates right to left. Parentheses can be used to control the order of the evaluation.

Operators	Priority
+ - ! ~ (unary)	Highest
* / %	..
+ - (binary)	..
<< >>	..
== !=	..
& ~&	..
^ ^~ ~^	..
~	..
&&	..
	..
? :	Lowest

Concatenation Operator

The concatenation operator `{}` is used for joining scalar elements into compound elements.

Example

```
parameter real taps[0:3] = {1.0, 2.0, 3.0, 4.0};
```

Expression Evaluation

The expression evaluation follows the order precedence described in the previous table. If the results of an expression can be determined without evaluating the entire expression, the remaining part of the expression is not evaluated, unless it contains analog expressions. This expression evaluation rule is known as short-circuiting.

Arithmetic Conversion

Verilog-A performs automatic conversion of numeric types based on the operation. For functions that take integers, real numbers are converted to integers by rounding to the nearest integer, with ties rounded away from zero (0). For operators, a common data type is determined based on the operands. If either operand is real, the other operand is converted to real.

Examples

```
a = 7.0 + 3; // 3 becomes 3.0 and then the addition is performed, a = 10.0
```

```
a = 1 / 3; // The result of this integer division is zero, a = 0.
```

```
a = 7.0 + 1 / 3; /* The 1/3 is evaluated by integer division, cast to 0.0 and added to 7.0, a = 7.0; */
```

Mathematical Functions

Verilog-A supports a wide range of functions to help in describing analog behavior. These include the standard mathematical functions, transcendental and hyperbolic functions, and a set of statistical functions.

Standard Mathematical Functions

The mathematical functions supported by Verilog-A are shown in the following table.

Advanced Design System 2008

Function	Description	Domain	Return value
$\ln()$	natural log	$x > 0$	real
$\log(x)$	log base 10	$x > 0$	real
$\exp(x)$	exponential	$X < 80$	real
$\text{sqrt}(x)$	square root	$x \geq 0$	real
$\text{min}(x,y)$	minimum of x and y	all x, y	if either is real, returns real, otherwise returns the type of x,y.
$\text{max}(x,y)$	maximum of x and y	all x, y	if either is real, returns real, otherwise returns the type of x,y.
$\text{abs}(x)$	absolute value	all x	same as x
$\text{pow}(x,y)$	x^y	if $x \geq 0$, all y; if $x < 0$, $\text{int}(y)$	real
$\text{floor}(x)$	floor	all x	real
$\text{ceil}(x)$	ceiling	all x	real

For the $\text{min}()$, $\text{max}()$, and $\text{abs}()$ functions, the derivative behavior is defined as:

$\text{min}(x,y)$ is equivalent to $(x < y) ? x : y$

$\text{max}(x,y)$ is equivalent to $(x > y) ? x : y$

$\text{abs}(x)$ is equivalent to $(x > 0) ? x : -x$

Transcendental Functions

The transcendental functions supported by Verilog-A are shown in the following table. All operands are integer or real and will be converted to real when necessary. The arguments to the trigonometric and hyperbolic functions are specified in radians.

The return values are real.

Function	Description	Domain
----------	-------------	--------

<code>sin(x)</code>	sine	all x
<code>cos(x)</code>	cosine	all x
<code>tan(x)</code>	tangent	$x \neq n(\pi/2)$, n is odd
<code>asin(x)</code>	arc-sine	$-1 \leq x \leq 1$
<code>acos(x)</code>	arc-cosine	$-1 \leq x \leq 1$
<code>atan(x)</code>	arc-tangent	all x
<code>atan2(x,y)</code>	arc-tangent of x/y	all x, all y
<code>hypot(x,y)</code>	$\sqrt{x^2 + y^2}$	all x, all y
<code>sinh(x)</code>	hyperbolic sine	$x < 80$
<code>cosh(x)</code>	hyperbolic cosine	$x < 80$
<code>tanh(x)</code>	hyperbolic tangent	all x
<code>asinh(x)</code>	arc-hyperbolic sine	all x
<code>acosh(x)</code>	arc-hyperbolic cosine	$x \geq 1$
<code>atanh(x)</code>	arch-hyperbolic tangent	$-1 \leq x \leq 1$

Statistical Functions

Verilog-A supports a variety of functions to provide statistical distributions. All parameters are real valued with the exception of `seed_expression`, an integer. The functions return a pseudo-random number, of type real, based on the distribution type. When a seed is passed to one of these functions, the seed is modified. The system functions return the same value for a given seed value.

The \$random Function

The `$random()` function returns a new 32-bit random number each time it is called. The return type is a signed integer.



Note

The modulus operator, `%`, can be used to restrict the return value. For $b > 0$, `$random %b` will restrict the random number to $(-b+1) : (b-1)$.

Syntax

```
$random( seed_expression );
```

where

The optional `seed_expression` can be used to control the random number generation and must be a signed integer variable.

Example

```
integer seed_value, random_value;
random_value = $random;
// returns a value between -31 and 31.
random_value = $random(seed_value) % 32;
```

The `$dist_uniform` and `$rdist_uniform` Functions

The `$dist_uniform()` and `$rdist_uniform()` functions return uniform distributions across the range. Use `$dist_uniform()` to return integer values and `$rdist_uniform()` to return real values.

Syntax

```
$dist_uniform( seed_expression , start_expression , end_expression );
```

```
$rdist_uniform( seed_expression , start_expression , end_expression );
```

Where the start and end real parameters bound the values returned. The start value must be smaller than the end value. The `$dist_uniform()` parameters `start_expression` and `end_expression` are integer values, and for `$rdist_uniform()`, are real values.

Example

```
// Returns integer values between 0:10  
random_value = $dist_uniform(mySeed, 0, 10);
```

The \$dist_normal and \$rdist_normal Functions

The `$dist_normal()` and `$rdist_normal()` functions return normal distributions around a mean value. Use `$dist_normal()` to return integer values and `$rdist_normal()` to return real values.

Syntax

```
$dist_normal( seed_expression , mean_expression , stdev_expression );
```

```
$rdist_normal( seed_expression , mean_expression , stdev_expression );
```

where

`stdev_expression` determines the shape (standard deviation) of the density function. It is an integer value for `$dist_normal` and a real value for `$rdist_normal`.

A `mean_expression` value of zero (0) and a `stdev_expression` of one (1) generates a Gaussian distribution. In general, larger numbers for `stdev_expression` spread out the returned values over a larger range. It is an integer value for `$dist_normal` and a real value for `$rdist_normal`.

The `mean_expression` parameter causes the average value of the return value to approach the `mean_expression`.

Example

```
// Returns a Gaussian distribution  
random_value = $rdist_normal(mySeed, 0.0, 1.0);
```

The \$dist_exponential and \$rdist_exponential Functions

The `$dist_exponential()` and `$rdist_exponential()` functions generate a distribution that follows an exponential. Use `$dist_exponential()` to return integer values and `$rdist_exponential()` to return real values.

Syntax

```
$dist_exponential( seed_expression , mean_expression );
```

```
$rdist_exponential( seed_expression , mean_expression );
```

where

`mean_expression` parameter causes the average value of the return value to approach the mean. The `mean_expression` value must be greater than zero (0). It is an integer value for `$dist_exponential` and a real value for `$rdist_exponential`.

Example

```
// Exponential distribution approaching 1  
random_value = $rdist_exponential(mySeed, 1);
```

The \$dist_poisson and \$rdist_poisson Functions

The `$dist_poisson()` and `$rdist_poisson()` functions return a Poisson distribution centered around a mean value. Use `$dist_poisson()` to return integer values and `$rdist_poisson()` to return real values.

Syntax

```
$dist_poisson( seed_expression , mean_expression );
```

```
$rdist_poisson( seed_expression , mean_expression );
```

where

mean_expression value must be greater than zero (0).

The mean_expression parameter causes the average value of the return value to approach the mean_expression). It is an integer value for \$dist_poisson and a real value for \$rdist_poisson.

Example

```
// Distribution around 1
random_value = $rdist_poisson(mySeed,1);
```

The \$dist_chi_square and \$rdist_chi_square Functions

The \$dist_chi_square() and \$rdist_chi_square() functions returns a Chi-Square distribution. Use \$dist_chi_square() to return integer values and \$rdist_chi_square() to return real values.

Syntax

```
$dist_chi_square( seed_expression , degree_of_freedom_expression );
```

```
$rdist_chi_square( seed_expression , degree_of_freedom_expression );
```

where

degree_of_freedom_expression parameter helps determine the shape of the density function. Larger values spread the returned values over a wider range. The degree_of_freedom_expression value must be greater than zero (0). It is an integer value for \$dist_chi_square and a real value for \$rdist_chi_square.

Example

```
// Chi-Square
random_value = $rdist_chi_square(mySeed,1.0);
```

The \$dist_t and \$rdist_t Functions

The `$dist_t()` and `$rdist_t()` functions returns a Student's T distribution of values. Use `$dist_t()` to return integer values and `$rdist_t()` to return real values.

Syntax

```
$dist_t( seed_expression , degree_of_freedom_expression );
```

```
$rdist_t( seed_expression , degree_of_freedom_expression );
```

where

`degree_of_freedom_expression` parameter helps determine the shape of the density function. Larger values spread the returned values over a wider range. The `degree_of_freedom_expression` must be greater than zero (0). It is an integer value for `$dist_t` and a real value for `$rdist_t`.

Example

```
// Student's T distribution of 1.0
random_value = $rdist_t(mySeed,1.0);
```

The \$dist_erlang and \$rdist_erlang Functions

The `$dist_erlang()` and `$rdist_erlang()` functions return values that form an Erlang random distribution. Use

`$dist_erlang()` to return integer values and `$rdist_erlang()` to return real values.

Syntax

```
$dist_erlang( seed_expression , _k_stage_expression_ , mean_expression );
```

```
$rdist_erlang( seed_expression , _k_stage_expression_ , mean_expression );
```

where

`mean_expression` and `_k_stage_expression_` values must be greater than zero (0). The `mean_expression` parameter causes the average value of the return value to approach this value. It is an integer value for `$dist_erlang` and a real value for `$rdist_erlang`.

Example

```
// Erlang distribution centered around 5.0 with a range of 2.0.  
random_value = $rdist_erlang(mySeed,2.0, 5.0);
```

Analog Operators and Filters

Analog operators have the same functional syntax as other operators and functions in Verilog-A, but they are special in that they maintain an internal state. This impacts how and where they may be used.

Because they maintain their internal state, analog operators are subject to several important restrictions. These are:

- Analog operators cannot be used inside conditional (`if` and `case`) or looping (`for`) statements unless the conditional expression is a genvar expression (genvars cannot change their value during the course of an analysis).
- Analog operators are not allowed in the repeat and while looping statements.
- Analog operators can only be used inside an analog block; they cannot be used inside user-defined analog functions.

Filters are analog functions that provide a means of modifying waveforms. A range of Laplace and Z-transform filter formulations are available. `transition()` and `slew()` are used to remove discontinuities from piecewise linear and piecewise continuous waveforms.

The `limexp()` operator provides a way to bound changes in exponential functions in order to improve convergence properties.

Tolerances

Most simulators use an iterative approach to solve the system of nonlinear equations, such as the Newton-Raphson algorithm. Some criteria is needed to indicate that the numerical solution is close enough to the true solution. Each equation has a tolerance defined and associated with it (in most cases a global tolerance is applied). However, the analog operators allow local tolerances to be applied to their equations.

Parameters

Some analog operators (Laplace and Z-transform filters) require arrays as arguments.

Examples

```
integer taps[0:3];
```

```
taps = {1, 2, 3, 4};
```

```
vout1 = zi_nd(vn, taps, {1});
```

```
vout2 = zi_nd(vn, {1, 2, 3, 4}, {1});
```

Time Derivative Operator

The time derivative operator, `ddt()`, computes the derivative of its argument with respect to time.

Syntax

```
ddt( expr )
```

where

`expr` is an expression with respect to which the derivative will be taken.

Example

```
I(n1,n2) <+ C * ddt(V(n1, n2));
```

Time Integrator Operator

The time integrator operator, `idt()`, computes the time integral of its argument.

Syntax

```
idt( expr [, ic [, assert [, abstol ]]] )
```

where

`expr` is an expression to be integrated over time.

`ic` is an optional expression specifying an initial condition.

`assert` is an optional integer expression that when true (non-zero), resets the integration.

`abstol` is a constant absolute tolerance to be applied to the input of the `idt()` operator and defines the largest signal level that can be considered to be negligible.

In DC analyses, the `idt()` operator returns the value of `ic` whenever `assert` is given and is true (non-zero). If `ic` is not given, `idt()` multiplies its argument by infinity for DC analyses. So if the system does not have feedback that forces the argument to zero, `ic` must be specified.

Example

```
V(out) <+ gain * idt(V(in) - V(out),0) + gain * V(in);
```

Circular Integrator Operator

The circular integrator operator, `idtmod()`, converts an expression argument into its indefinitely integrated form.

Syntax

```
idtmod( expr [, ic [, modulus [, offset [, abstol ]]] ] )
```

where

`expr` is the expression to be integrated.

`ic` is an optional expression specifying an initial condition. The default value is zero (0).

`modulus` is a positive-valued expression which specifies the value at which the output of `idtmod()` is reset. If not

specified, `idtmod()` behaves like the `idt()` operator and performs no limiting on the output of the integrator.

`offset` is a dynamic value added to the integration. The default of `offset` is zero (0).

`abstol` is a constant absolute tolerance to be applied to the input of the `idtmod()` operator and defines the largest signal level that can be considered to be negligible.

The `modulus` and `offset` parameters define the bounds of the integral. The output of the `idtmod()` function always remains in the range:

```
offset <= idtmod_output < offset+modulus
```

Example

```
phase = idtmod(fc + gain * V(in), 0 , 1, 0);
```

Absolute Delay Operator

The absolute delay operator, `absdelay()`, is used to provide delay for a continuous waveform.

Syntax

```
absdelay( expr , time_delay [ , max_delay ] )
```

where

`expr` is the expression to be delayed

`time_delay` is a nonnegative expression that defines how much `expr` is to be delayed

If the optional `max_delay` is specified, the value of `time_delay` can change during a simulation, as long as it remains positive and less than `max_delay`. If `max_delay` is not specified, any changes to `time_delay` are ignored. If `max_delay` is specified and changed, any changes are ignored and the simulator will continue to use the initial value.

In DC and OP (operating point) analyses, `absdelay()` returns the value of `expr`. In AC and small-signal analyses, the input waveform `expr` is phase shifted according to:

$$Y(\omega) = X(\omega) \cdot e^{-j\omega \text{time_delay}}$$

In the time domain, `absdelay()` introduces a delay to the instantaneous value of `expr` according to the formula:

$$y(t) = x(t - \text{time_delay}) \quad \text{where } \text{time_delay} \geq 0$$

Example

```
V_delayed = absdelay( V(in), time_delay )
```

Transition Filter

The transition filter, `transition()`, is used to smooth out piecewise constant waveforms. The transition filter should be used for transitions and delays on digital signals as it provides controlled transitions between discrete signal levels. For smoothly varying waveforms, use the slew filter, `slew()`.

Syntax

```
transition( expr [, time_delay [, rise_time [, fall_time [, time_tol ]]] ] )
```

where all values are real and `time_delay`, `rise_time`, `fall_time`, and `time_tol` are optional and

`expr` is the input expression waveform to be delayed

time_delay is the delay time and must be ≥ 0 (defaults to zero (0))

rise_time is the transition rise time and must be ≥ 0

fall_time is the transition the fall time and must be ≥ 0 (If fall_time is not specified and rise_time is specified, the value of rise_time will be used)

time_tol is the absolute tolerance and must be > 0

The `transition()` filter forces all the positive transitions of the waveform `expr` to have a rise time of `rise_time` and all negative transitions to have a fall time of `fall_time` (after an initial delay of `time_delay`).

The `transition()` function returns a real number which describes a piecewise linear function. It forces the simulator to put time-points at both corners of a transition and to adequately resolve the transitions (if `time_tol` is not specified).

In DC analyses, the output waveform is identical to the input waveform `expr`. For AC analyses, the transfer function is modeled as having unity transmission across all frequencies.

The following figure shows an example of a `transition()` filter on a pulse waveform.

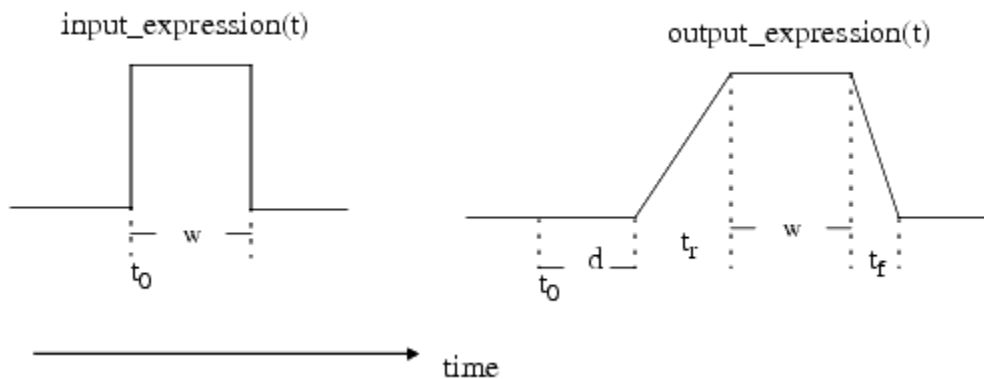

Transition Filter on Pulse Waveform

If interrupted on a rising transition, the function will attempt to finish the transition in the specified time with the following rules (see the following figure):

- If the new time value is below the value at the time of the interruption, the function will use the old destination as the origin.
- If the new destination is above the value at the time of the interruption, the first origin is retained.

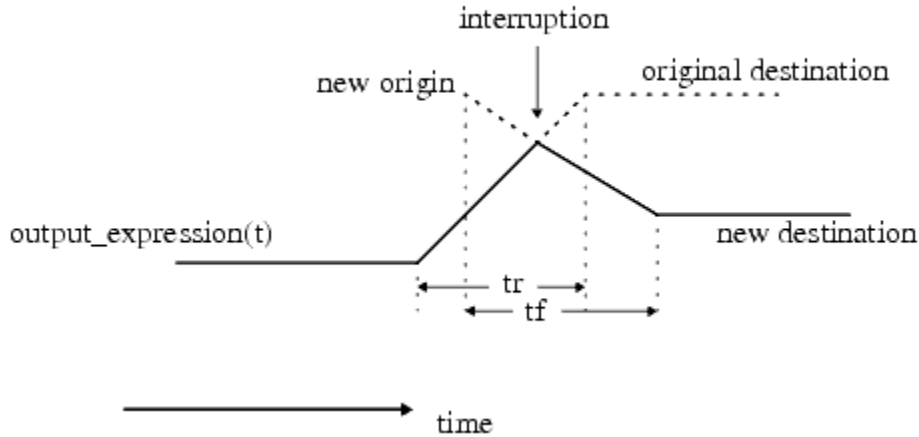

The TransitionFunction Completion after Interruption

Slew Filter

The slew filter, `slew()`, provides a means to bound the rate of change of a waveform. A typical use of this analog operator would be to generate continuous signals from a piecewise continuous signal. Discrete-valued signals would use the `transition()` function.

Syntax

```
slew( expr [, max_pos_slew_rate [, max_neg_slew_rate ]] )
```

where all the arguments are real numbers and

`expr` in the input waveform expression

`max_pos_slew_rate` is the maximum positive slew rate allowed. `max_pos_slew_rate` is optional and must be > 0

`max_neg_slew_rate` is the maximum negative slew rate allowed (`max_neg_slew_rate` is optional and must be < 0; If not specified, it defaults to the negative of `max_pos_slew_rate`)

Any slope of the waveform `expr` that is larger than `max_pos_slew_rate` is limited to `max_pos_slew_rate` for positive transitions and limited to `max_neg_slew_rate` for negative transitions. If no rates are specified, `slew()` returns `expr` unchanged. If the slope of `expr` is in-between the maximum slew rates, the input `expr` is returned.

In DC analyses, the input `expr` is passed through the filter unchanged. In AC small-signal analyses, the `slew()` operator has a unity transfer function. In this case it has zero transmission.

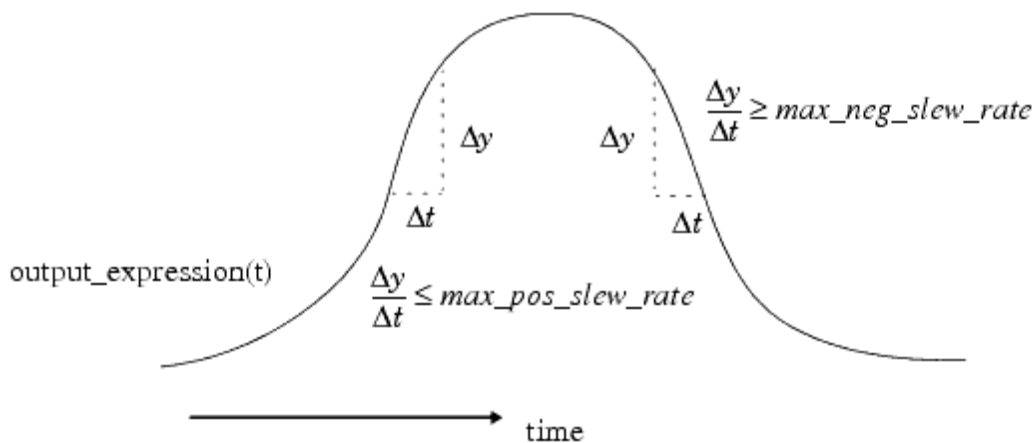

Slew Rate Limiting of Slope

Last Crossing Function

The last crossing function, `last_crossing()`, is used to find where a signal expression last crossed zero (0).

Syntax

```
last_crossing( expr , dir )
```

where

`expr` is the signal expression

`dir` is an integer flag with values -1, 0, +1

If `dir` is set to 0 or is not specified, the last crossing will be detected on both positive and negative signal crossings. If `dir` is +1 or -1, then the last crossing will only be detected on rising edge (falling edge) transitions of the signal.

If `expr` has not crossed zero, the function will return a negative value.

Limited Exponential

An alternative function to the `exp()` standard mathematical function is the `limexp()` function. The `limexp()` function is mathematically equivalent to the `exp()` function but the simulator keeps track of the value of the argument at the previous Newton-Raphson iteration and limits the amount of change from one iteration to another. The purpose of this function is to provide better convergence. The simulator will not converge until the return value of `limexp()` equals the exponential `exp()` for that input.

Syntax

```
limexp(arg);
```

Example

```
Is = Is0 * limexp(Vj / $vt);
```

Laplace Transform Filters

Laplace transform filters are used to implement lumped linear continuous-time filters.

laplace_zp()

The `laplace_zp()` is used to implement the zero-pole form of the Laplace transform filter.

Syntax

```
laplace_zp( expr ,#,#)
```

where

`expr` is the expression to be transformed.

ζ (zeta) is a vector of M pairs of real numbers where each pair of numbers represents a zero. For each pair, the first number is the real part of the zero, the second number is the imaginary part.

ρ (rho) is a vector of N real pairs, one for each pole. The poles of the function are described in the same manner as the zeros (the first number is the real part, the second number is the imaginary part).

The transfer function is:

$$H(s) = \frac{\prod_{k=0}^{M-1} \left(1 - \frac{s}{\zeta_k^r + j\zeta_k^i} \right)}{\prod_{k=0}^{N-1} \left(1 - \frac{s}{\rho_k^r + j\rho_k^i} \right)}$$

where ζ_k^r and ζ_k^i are the real and imaginary parts of the k th zero and ρ_k^r and ρ_k^i are the real and imaginary parts of the k th pole. For a real pole or real zero root, the imaginary term is specified as zero (0). If a root is complex, its conjugate must also be specified. If a root is zero (0), it is implemented as s , rather than $(1 - s/r)$, where r is the root.

laplace_zd()

The `laplace_zd()` represents the zero-denominator form of the Laplace transform filter.

Syntax

```
laplace_zd( expr ,#,d )
```

where

`expr` is the expression to be transformed.

ζ (zeta) is a vector of M pairs of real numbers where each pair of numbers represents a zero. For each pair, the first number is the real part of the zero, the second number is the imaginary part.

`d` is a vector of N real numbers representing the coefficients of the denominator.

The transfer function is:

$$H(s) = \frac{\prod_{k=0}^{M-1} \left(1 - \frac{s}{\zeta_k^r + j\zeta_k^i} \right)}{\sum_{k=0}^{N-1} d_k s^k}$$

where ζ_k^r and ζ_k^i are the real and imaginary parts of the k th zero and d_k is the coefficient of the k th power of s in the denominator. For a real zero, the imaginary term is specified as zero (0). If a root is complex, its conjugate must also be specified. If a root is zero (0), it is implemented as s , rather than $(1 - s/r)$, where r is the root.

laplace_np()

The `laplace_np()` implements the numerator-pole form of the Laplace transform filter.

Syntax

```
laplace_np( expr , n ,#)
```

where

`expr` is the expression to be transformed.

`n` is a vector of M pairs of real numbers containing the coefficients of the numerator.

`ρ` (rho) is a vector of N pairs of real numbers. Each pair represents a pole, the first number in the pair is the real part of the pole and the second is the imaginary part.

The transfer function is:

$$H(s) = \frac{\sum_{k=0}^{M-1} n_k s^k}{\prod_{k=0}^{N-1} \left(1 - \frac{s}{\rho_k^r + j\rho_k^i} \right)}$$

where ρ_k^r and ρ_k^i are the real and imaginary parts of the k th pole and n_k is the coefficient of the k th power of s in the numerator. For a real pole, the imaginary term is specified as zero (0). If a pole is complex, its conjugate must also be specified. If a pole is zero (0), it is implemented as s , rather than $(1 - s/r)$, where r is the pole.

laplace_nd()

The `laplace_nd()` implements the numerator-denominator form of the Laplace transform filter.

Syntax

```
laplace_nd( expr , n , d )
```

where

`expr` is the expression to be transformed.

`n` is a vector of M pairs of real numbers containing the coefficients of the numerator.

`d` is a vector of N real numbers containing the coefficients of the denominator.

The transfer function is:

$$H(s) = \frac{\sum_{k=0}^M n_k s^k}{\sum_{k=0}^N d_k s^k}$$

where n_k is the coefficient of the k th power of s in the numerator, and d_k is the coefficient of the k th power of s in the denominator.

Z-Transform Filters

The Z-transform filters implement linear discrete-time filters. Each filter uses a parameter T which specifies the filter's sampling period. The zeros argument may be represented as a null argument. The null argument is produced by two

adjacent commas (,,) in the argument list.

All Z-transform filters share three common arguments: T , t , and t0 .

T specifies the period of the filter, is mandatory, and must be positive.

t specifies the transition time, is optional, and must be non-negative.

t0 specifies the first transition time. If it is not supplied, the first transition is at t =0.

zi_zp()

The `zi_zp()` operator implements the zero-pole form of the Z-transform filter.

Syntax

```
zi_zp( expr , # , # , # [, # [, t0 ] ] )
```

where

`expr` is the expression to be transformed.

ζ (zeta) is a vector of M pairs of real numbers. Each pair represents a zero, the first number in the pair is the real part of the zero (0) and the second is the imaginary part.

ρ (rho) is a vector of N real pairs, one for each pole, represented in the same manner as the zeros.

The transfer function is:

$$H(z) = \frac{\prod_{k=0}^{M-1} 1 - z^{-1}(\zeta_k^r + j\zeta_k^i)}{\prod_{k=0}^{N-1} 1 - z^{-1}(\rho_k^r + j\rho_k^i)}$$

where ζ_k^r and ζ_k^i are the real and imaginary parts of the k th zero, while ρ_k^r and ρ_k^i are the real and imaginary parts of the k th pole. If a root (a pole or zero) is real, the imaginary part must be specified as zero (0). If a root is complex, its conjugate must also be present. If a root is zero (0), the term associated with it is implemented as z , rather than as $(1 - z / r)$ where r is the root.

zi_zd()

The `zi_zd()` operator implements the zero-denominator form of the Z-transform filter.

Syntax

```
zi_zd( expr , # , d , # [, # [, t0 ] ] )
```

where

`expr` is the expression to be transformed.

ζ (zeta) is a vector of M pairs of real numbers. Each pair of represents a zero, the first number in the pair is the real part of the zero and the second is the imaginary part.

`d` is a vector of N real numbers containing the coefficients of the denominator.

The transfer function is:

$$H(z) = \frac{\prod_{k=0}^{M-1} (1 - z^{-1}(\zeta_k^r + j\zeta_k^i))}{\sum_{k=0}^{N-1} d_k z^{-k}}$$

where ζ_k^r and ζ_k^i are the real and imaginary parts of the k th zero, while d_k is the coefficient of the k th power of z in the denominator. If a zero is real, the imaginary part must be specified as zero (0). If a zero is complex, its conjugate must also be present. If a zero is zero (0), then the term associated with it is implemented as z , rather than $(1 - z/\zeta)$, where ζ is the zero.

zi_np()

The `zi_np()` implements the numerator-pole form of the Z-transform filter.

Syntax

```
zi_np( expr , n , # , # [ , # [ , t0 ] ] )
```

where

`expr` is the expression to be transformed.

`n` is a vector of M real numbers containing the coefficients of the numerator.

`p` (ρ) is a vector of N pairs of real numbers where each pair represents a pole, the first number in the pair is the real part of the pole and the second is the imaginary part.

The transfer function is:

$$H(z) = \frac{\sum_{k=0}^{M-1} n_k \cdot z^{-k}}{\prod_{k=0}^{N-1} (1 - z^{-1}(\rho_k^r + j\rho_k^i))}$$

where n_k is the coefficient of the k th power of z in the numerator, while ρ_k^r and ρ_k^i are the real and imaginary parts of the k th pole. If a pole is real, the imaginary part must be specified as zero (0). If a pole is complex, its conjugate must also be specified. If a pole is zero (0), then the term associated with it is implemented as z , rather than as $(1 - z/\rho)$ where ρ is the pole.

zi_nd()

The `zi_nd()` implements the numerator-denominator form of the Z-transform filter.

Syntax

```
zi_nd( expr , n , d , # [, # [, t0 ] ] )
```

where

`expr` is the expression to be transformed.

`n` is a vector of M real numbers containing the coefficients of the numerator.

`d` is a vector of N real numbers containing the coefficients of the denominator.

The transfer function is:

$$H(z) = \frac{\sum_{k=0}^{M-1} n_k z^{-k}}{\sum_{k=0}^{N-1} d_k z^{-k}}$$

where n_k is the coefficient of the k th power of s in the numerator and d_k is the coefficient of the k th power of z in the denominator.

Analog Events

The analog behavior of a component can be controlled using events. Events have the characteristics of no time duration and events can be triggered and detected in different parts of the behavioral model.

There are two types of analog events: global events and monitored events.

- Global events are the `initial_step` event and the `final_step` event.
- Monitored events are the `cross()` function and the `timer()` functions.

Events are detected using the `@` operator. Null arguments are not allowed.

Global Events

A global event can be generated by the simulator at various times during the simulation. A Verilog-A module cannot generate an event but can only detect them using an event expression. The two predefined global events are `initial_step` and `final_step`. These events are triggered at the initial (first) and final (last) point in an analysis.

The `initial_step` Event

The `initial_step` event is triggered at the first time point of an analysis.

Syntax

```
@(initial_step [( list_of_analyses )])
```

where `list_of_analyses` is an optional comma separated list of quoted strings to be compared during the simulation.

An optional argument can specify a comma separated list of analyses for the active event. If a name matches the current analysis name, an event is triggered. If no list is given the `initial_step` global event is active during the first point (or during the initial DC analysis) of every analysis.

Example

```
@(initial_step("tran","ac","dc"))
```

The final_step Event

The `final_step` event is triggered at the last time point of an analysis.

Syntax

```
@(final_step [( list_of_analyses )])
```

where `list_of_analyses` is an optional comma separated list of quoted strings to be compared during the simulation.

An optional argument can specify a comma separated list of analyses for the active event. If a name matches the current analysis name, an event is triggered. If no list is given, the `final_step` global event is active during the last point of an analysis.

Example

```
@(final_step("tran"))
```

Global Event Return Codes

Events provide a useful mechanism for executing code that should only occur at the first and last points of a simulation. The following table defines the return code for the particular event and analysis type. The return codes in each column are in the sequence OP p1 pN, where OP indicates the Operating Point, and p1 pN indicates the first and last points.

Analysis	DCOP OP	TRAN OP p1 pN	AC OP p1 pN	NOISE OP p1 pN
initial_step()	1	1 0 0	1 0 0	1 0 0
initial_step("ac")	0	0 0 0	1 0 0	0 0 0
initial_step("noise")	0	0 0 0	0 0 0	1 0 0
initial_step("tran")	0	1 0 0	0 0 0	0 0 0
initial_step("dc")	1	0 0 0	0 0 0	0 0 0
initial_step(unknown)	0	0 0 0	0 0 0	0 0 0
final_step()	0	0 0 1	0 0 1	0 0 1
final_step("ac")	0	0 0 0	0 0 1	0 0 0
final_step("noise")	0	0 0 0	0 0 0	0 0 1
final_step("tran")	0	0 0 1	0 0 0	0 0 0
final_step("dc")	1	0 0 0	0 0 0	0 0 0
final_step(unknown)	1	0 0 0	0 0 0	0 0 0

Monitored Events

Monitored events are triggered due to changes in signals, simulation time, or other runtime conditions during the simulation.

The cross Function

The cross function, `cross()`, is used for generating a monitored analog event. It is used to detect threshold crossings in analog signals when the expression crosses zero in the direction specified. The `cross()` function can control the timestep to accurately resolve the crossing. The format is:

```
cross( expr [, dir [, time_tol [, expr_tol ]]] );
```

where

`expr` is a required argument

`dir` is an optional argument that is an integer expression

`time_tol` and `expr_tol` are optional arguments that are real

If the tolerances are not defined, they are set by the simulator. If either or both tolerances are defined, then the direction of the crossing must also be defined. The direction can only evaluate to +1, -1, or 0. If `dir` is set to 0 or is not specified, the event and timestep control will occur on both positive and negative signal crossings. If `dir` is +1, then the event and timestep control occurs on the rising transitions of the signal only. If `dir` is -1, then the event and timestep control occurs on the falling transitions of the signal only. For other transitions of the signal, the `cross()` function will not generate an event. The `expr_tol` and `time_tol` arguments represent the maximum allowable error between the estimated crossing point and the actual crossing point.

Example

The following description of a sample-and-hold illustrates how the `cross()` function can be used.

```
module sample_and_hold (in, out, sample);
output out;
input in, sample;
electrical in, out, sample;
real state;
analog begin
    @(cross(V(sample) -2.0, +1.0))
    state = V(in);
    V(out) <+ transition(state, 0, 10n);
end
endmodule
```

The `cross()` function is an analog operator and shares the same restrictions as other analog operators. It cannot be used inside an `if()` `**` or `case()` statement unless the conditional expression is a genvar expression. Also, `cross()` is not allowed in the `repeat()` and `while()` statements but is allowed in the `analog for`, `analog_for`, statements.

The timer Function

The timer function, `timer()`, is used to generate analog events. It is used to detect specific points in time.

Syntax

```
timer ( start_time [ , period ] );
```

where

`start_time` is a required argument

`period` and `time_tol` are optional arguments

The `timer()` function schedules an event to occur at an absolute time (`start_time`). If the period is specified as greater than zero, the timer function schedules subsequent events at all integer multiples of period.

Example

A pseudo-random bit stream generator is an example of how the `timer()` function can be used.

```
module bitStreamGen (out);
output out;
electrical out;
parameter period = 1.0;
integer x;
analog begin
    @(timer(0, period))
    x = $random + 0.5;
    V(out) <+ transition( x, 0.0 );
end
endmodule
```

Event or Operator

The `or` operator provides a mechanism to trigger an event if any one of the events specified occurs.

Example

```
@(initial_step or initial_step("static"))
```

Event Triggered Statements

When an event is triggered, the statement block following the event is executed. The statement block has two restrictions.

- The statements in the statement block cannot have expressions that include analog operators.
- The statements in the statement block cannot be contribution statements.

Mixed Signal Behavior Models

The Verilog-AMS Hardware Description Language (HDL) provides a way to describe analog, digital, and mixed signal aspects of a circuit. The language supports the use of both digital and analog simulators and handles the mixed signal interaction between the simulators and modules. The language is hierarchical and so supports top-down design of systems.

This topic defines terms, describes the syntax, and explains the language usage for modeling analog and mixed signal blocks. For a detailed description of the digital aspects of the language, please refer to the complete IEEE 1364-1995 Verilog HDL document.

Introduction to AMS

In Verilog-AMS HDL, the domain of a value determines the whether the variable is calculated in the continuous domain (analog) or in the discrete domain (digital). Register contents and the states of gate primitives are determined in the discrete domain. The potentials and flows (for the electrical nature, this would be voltages and currents) are calculated in the continuous domain. Real and integer variables are calculated in both domains depending on how their values are assigned. Values in the continuous (analog) domain vary continuously. Values calculated in the discrete domain change instantaneously at interval multiples of some minimum resolvable time.

Statements in a Verilog-AMS module description which appear in an analog block are said to be in the continuous, or analog, context. All other statements are said to be in the discrete, or digital, context. A given variable can only be assigned in one context, not both, and its domain is then determined from the context in which it was assigned.

As described in [Verilog-A and Verilog-AMS Modules](#), Verilog-AMS supports hierarchical structures for top-down design. Modules communicate between other modules at their level and other levels through input, output, and bidirectional

ports, which represent a physical connection between the expressions in the different modules. These expressions are called nets, and so any instantiated module has two nets, one in the instantiating module, the other in the instantiated module.

Nets can be declared with a discrete or analog discipline, or with no discipline. Nets with no discipline are considered neutral interconnects. Verilog-AMS permits only digital blocks and primitives to drive a discrete net. These nets are called drivers. Only analog blocks can contribute to an analog net. These are called contributions. A signal is a hierarchical collection of contiguous (through ports) nets. A signal is said to be a digital signal if all of the nets that make up the signal are in the discrete domain. Likewise, a signal is said to be an analog signal if all the nets that make up the signal are in the continuous domain. A mixed signal consists of nets from both the discrete and continuous domains.

Ports are named in a similar fashion. Ports with only analog connections are called analog ports, ports whose connections are both digital is a digital port, and a port with a digital and analog connection is a mixed port.

During simulation, drivers in the discrete domain are automatically converted to contributions via digital-to-analog connection modules (D2As), which are inserted by the simulator. The resolved analog signal is then converted back to a digital value. Connect modules are inserted only at port boundaries. Therefore, when a module contains multiple continuous assignment statements, they are handled by a single connect module.

The discipline of a net determines which connect modules to use. [Discipline Resolution](#) describes how the resolution is determined.

Describing Behavior for Analog and Digital Simulation

High frequency and RF systems often incorporate digital processing and control. In order to develop, design, and verify these complete systems, simulations need to include both the digital and analog content and be tested with complex digital stimuli and measurements. Verilog-AMS provides support for analog and digital behavior through different expression blocks in modules, including initial blocks, always blocks, and analog blocks. Digital behavior is typically described in the initial and always blocks or assignment statements or declarations. A module can have any number of initial and always blocks, but can include only one analog block.

In the continuous (or analog) domain, nets and variables are known as continuous nets and continuous variables. In the discrete (digital) domain, nets, variables, and regs are known as discrete nets, discrete variables, and discrete regs.

Information (values of registers, variables) can be referenced from one domain in the other. Each domain can read the values of the nets and variables; however, variables can be set (written) only within the context of their own domain.

Verilog-AMS supports:

- Accessing discrete primaries (e.g., nets, regs, or variables) from a continuous context (analog block)
- Accessing continuous primaries (e.g., flows, potentials, or variables) from a discrete context

- Detecting discrete events in a continuous context
- Detecting continuous events in a discrete context

Events are detected based on a synchronization algorithm. This algorithm also determines when the changes in nets and variables from one domain are available in the other. Examples showing the steps necessary to access variables and detect events are described in [Accessing Discrete Nets and Variables from a Continuous Context](#).

Accessing Discrete Nets and Variables from a Continuous Context

There are certain restrictions when accessing nets and variables in the discrete domain from the continuous domain, because the data types in the continuous domain are more restrictive than those in the discrete domain. Certain data types cannot be accessed. The following table lists types that can be accessed.

Discrete Data Types Accessible from a Continuous Context

Discrete (net, reg, variable) Type	Equivalent Continuous Variable Type	Accessibility
real	real	Discrete reals can be accessed in the continuous context as real numbers.
integer	integer	Discrete integers can be accessed in the continuous context.
bit	integer	<p>Discrete bit and bit groupings (buses and part selections) are accessed in the continuous context as integer numbers.</p> <p>Bit 31, the sign bit, is always set to zero (0). The lowest bit of the bit grouping (bus) is mapped to the 0th bit of the integer. The next bit of the bus is mapped to the 1st bit of the integer, etc.</p> <p>For buses of width less than 31 bits, the higher bits of the integer are set to zero (0).</p> <p>Access to discrete bit groupings with greater than 31 bits is illegal.</p>

The following example illustrates how to access the variables from the discrete domain module.

```

`define HIGH 5
`define LOW 0
module Basic_A2D(digital_net, analog_net);
input digital_net;
wire digital_net;
logic digital_net;
output analog_net;
electrical analog_net;

```

```
real value;
analog begin
  case (digital_net)
    1'b1: value = `HIGH;
    1'bx: value = value; // retain value
    1'b0: value = `LOW;
    1'bz: value = (`HIGH+`LOW)/2;
  endcase
  V(analog_net) <+ value;
end
endmodule
```

Accessing X and Z Bits of a Discrete Net in a Continuous Context

In the discrete domain nets can contain bits which are set to X (unknown) or Z (high impedance). Verilog-AMS HDL supports accessing 4-state logic values of nets within the analog context. Before access in the analog context, the X and Z states must be translated to equivalent analog real or integer values. The language provides the following specific features to perform this conversion:

- the case equality operator (===)
- the case inequality operator (!==)
- the case, casex, and casez statements
- binary, octal and hexadecimal numeric constants which can contain X and Z as digits

The case equality and case inequality operators have the same precedence as the equality operator. An if-else-if statement using the case equality operators also can be used to perform the 4-state logic value comparisons. Digital net and digital binary constant operands can also be accessed from analog context expressions; however, it is an error if these operands return x or z bit values when solved or if the value of the digital variable being accessed in the analog context goes to either X or Z.

If floating point arithmetic results in infinite or errors, these numbers are represented by special values representing plus and minus infinity and Not-a-Number (NaN). These special numbers can be used in digital expressions; however, it is illegal to assign these values to a branch through contribution in the analog context.

Accessing Continuous Nets and Variables from a Discrete Context

All continuous nets can be probed from a discrete context using the appropriate access functions. All probes that are legal in a continuous context of a module are also legal in the discrete context of a module.

Continuous variables can be read from any discrete context in the same module where these variables are declared. Since the discrete domain can fully represent all continuous types, a continuous variable is fully visible when it is accessed in a discrete context.

Detecting Discrete Events in a Continuous Context

Events in the discrete domain can be detected in a Verilog-AMS HDL continuous context. The arguments supplied to discrete events in continuous contexts are in the discrete context. A discrete event in a continuous context is non-blocking, as are other event types allowed in continuous contexts.

Detecting Continuous Events in a Discrete Context

Monitored continuous events can be detected in a discrete context. The arguments supplied to these events are in the continuous context. A continuous event in a discrete context is blocking, just like other discrete events.

Analog functions can only be called from a continuous context. Similarly, digital functions can only be called from a digital context.

Concurrency (Synchronization)

Verilog-AMS HDL manages synchronization between the continuous and discrete domains. Simulation in the discrete domain proceeds in integer multiples of the digital tick (the smallest value of the second argument of the timescale directive. Values calculated in the digital domain remain constant between digital ticks, changing only at digital ticks.

Simulation in the continuous domain proceeds continuously, at the time steps determined by the analog simulation process. For this reason, there is no time granularity below which continuous values can be guaranteed to be constant.

Discipline Resolution

As discussed previously, a mixed signal is a collection of nets, some with discrete disciplines and some with continuous disciplines, some with undeclared disciplines. The process of discipline resolution follows a set of rules to assign disciplines to those nets whose discipline is undeclared. This is necessary to control auto-insertion of connect modules, which follow the rules embodied in connect statements.

The discipline assignments are based on:

- discipline declarations
- default_discipline directives
- the design's hierarchical connectivity

The discipline of all of the net segments for every mixed signal is first resolved, then connect modules are inserted automatically.

Connect Modules

Once undeclared nets' disciplines have been resolved, connect modules are automatically inserted to connect the design hierarchy's mixed nets (the nets with continuous and discrete disciplines connected) together. The continuous and discrete disciplines of the ports of the connect modules as well as their directions are used to determine the rules in which the module can be inserted automatically.

Connect module declarations with matching port discipline declarations and directions are instantiated so as to connect the continuous and discrete domains of the mixed nets. Supported directional qualifiers are shown in the following table.

Supported Directional Qualifiers for Connect Modules

Continuous	Discrete
input	output
output	input
inout	inout

The connect module is a special form of a module and follows similar syntax.

Syntax

```
connectmodule module_identifier ( connectmod_port_identifier , connectmod_port_identifier ) ;  
  
[ module_items ]  
  
endmodule
```

Connect module specification statements

The user can specify any number of connect modules. Specification statements provide a means for the designer to choose or specify the connect modules in the design.

Connect specification statements:

- Specify which connect modules are used (including parameterization) for connecting given discrete and continuous disciplines
- Override the connect module default disciplines and port directions
- Resolve incompatible disciplines

Syntax

```
connectrules connectrule_identifier ;

{ connect_insertion | connect_resolution }

endconnectrules
```

The connect module specification statement has two forms, the auto-insertion specification and the discipline resolution specification described below.

Connect module auto-insertion specification statement

The connect module insertion specification statement determines which connect modules will be inserted automatically when mixed nets of the appropriate types are encountered. It chooses the connect module `_connect_module_identifier` based on the type of mixed nets in the declaration.

There can be multiple connect module declarations of a given discipline pair. The specification statement specifies which connect module is to be used in the auto-insertion process. Parameters of the connect module declaration can be specified by providing a connect attributes list.

Syntax

```
connect connect_module_identifier

[ merged|split ] [ #( .parameter_identifier ( expression ) [...]) ]

[[ direction ] discipline_identifier , [ input | output | inout ] discipline_identifier ]
[,...] ;
```

Examples

Connect modules may be reused for different (but compatible) disciplines by specifying discipline combinations in which the connect module can be used as shown in the following syntax for this form:

```
connect connect_module_identifier connect_attributes discipline_identifier ,
discipline_identifier ;
```

where the specified disciplines must be compatible for both the continuous and discrete disciplines of the connect module. A module can be used both as a unidirectional and bidirectional connect module by overriding the port

directions of the connect module. This allows the user to specify the connect rules, rather than having to search the entire library. The syntax for this form is:

```
connect connect_module_identifier connect_attributes direction discipline_identifier, direction  
discipline_identifier ;
```

where the specified disciplines must be compatible for both the continuous and discrete disciplines of the connect module and the specified directions define the type of connect module.

Discipline resolution connect statement

When multiple nets with compatible discipline are part of the same mixed net, the discipline resolution connect statement specifies which particular discipline to use during the discipline resolution process.

Syntax

```
connect discipline_list resolve to discipline_identifier ;
```

If there is an exact match for the set of disciplines specified in the *discipline_list*, the resolved discipline would be given by the specified rule. If more than one specified rule that applies to a given case is found, the simulator will issue a warning and the first match is used.

If there is not an exact fit, then the resolved discipline is chosen based on the subset of the rules specified. When there is more than one subset matching a set of disciplines, the simulator issues a warning message and applies the first subset rule that satisfies the current case.

Examples

```
connect a,b,c resolve to c;
```

```
connect a,b resolve to a;
```

For the above set of connect rule specifications,

disciplines a,b would resolve to discipline a.

disciplines *a,b,c* would resolve to discipline *c*.

disciplines *a,c* would resolve to discipline *c*.

Passing Parameters [Click here to show related information on EEs of Web site!](#)

The attribute method may be used with the connect statement to specify parameter values to pass into the connect module so as to override the default values.

Examples

```
connect a2d_cmos1 #(.tdel(3.5n), .vhi(3.0));
```

In this example, the parameter *tdel* is set to 3.5n and the parameter *vhi* is set to 3.0. The new values will override the default values for the connect module *a2d_cmos1*.

Setting connect_mode

Additional segregation of connect modules at each level of the hierarchy can be controlled by the *connect_mode* value. Setting *connect_mode* to *split* or *merged* defines whether all ports of a common discrete discipline and port direction will either share a connect module or have individual connect modules.

The connect modules are inserted hierarchically based on the net disciplines and ports at each level of the hierarchy. The *connect_mode* *split* and *merged* informs the simulator to try to apply that connect mode. The *merged* mode is the default.

merged informs the simulator to try to group all the ports (whether input, output, or inout) into one net and use one connect module.

If more than one input port is connected at a net of a signal, the connect mode *split* forces the simulator to use one connect module for each port that converts between the net discipline and the port discipline.

Example

```
connect a2d_cmos1 split #(.tdel(3.5n), .vhi(3.0));
```

informs the simulator to use separate ports.

Naming Connect Modules

Connection names follow a convention. For example, when the `merged` connect mode is used, one or more ports have a given discipline at their bottom connection, call it `BottomDiscipline`, and a common signal, `CommonSignal`, of different discipline at their top connection. A single connect module, `ModuleName`, is connected between the top signal and the bottom signals. In this case, the instance name of the connect module is derived from the signal name, module name, and the bottom discipline as (note the double underscore):

```
CommonSignal__ModuleName__BottomDiscipline
```

In the `split` case, consider a module with a given discipline at their bottom connection and a common signal of another discipline, `TopDiscipline`, at their top connection. One module instance is instantiated for each port. For this example, the instance name of the connect module would be

```
CommonSignal__InstName__PortName
```

where `InstName` and `PortName` are the local instance and port names.

Driver-Receiver Segregation

If the signal has both analog and digital segments in its hierarchy, it is a mixed signal, otherwise, it retains the internal representation of the analog or digital signal. In the case of a mixed signal, the appropriate conversion elements are inserted (manually or automatically) based on these rules:

- All the analog segments of a mixed signal are representations of a single analog node.
- Each of the non-contiguous digital segments of a signal is represented internally as a separate digital signal.
- Each non-contiguous digital segment is segregated into the collection of drivers of the segment and the collection of receivers of the segment.

In the digital domain, signals can have drivers and receivers. A driver makes a contribution to the state of the signal whereas a receiver accesses (reads) the state of the signal.

Driver Access Functions and Net Resolution

Access to individual drivers (a process that assigns a value to the signal or an output port of a module) and net resolution are used for accurate implementation of connect modules.

The driver access functions apply only to access drivers found in ordinary modules (not to those found in connect modules). The driver access functions can only be called from connect modules. A signal can have any number of drivers and for each driver the current status, value, and strength can be accessed through the appropriate function.

`$driver_count`

`$driver_count` returns an integer representing the number of drivers associated with the signal.

Syntax

```
$driver_count(signal_name)
```

returns the number of drivers associated with the signal *signal_name*.

Example

```
for ( i = 0; i < $driver_count(d); i=i+1)
```

The drivers are arbitrarily numbered from 0 to N-1, where N is the total number of ordinary drivers contributing to the signal value.

`$driver_state`

`$driver_state` returns the current value contribution of a specific driver to the state of the signal.

Syntax

```
$driver_state(signal_name, driver_index)
```

Returns the state of the driver, where *signal_name* is the name of the signal and *driver_index* is an integer value between 0 and N-1, where N is the total number of drivers contributing to the signal value. The state value is returned as 0, 1, X or Z.

Example

```
if ( $driver_state(d,i) == 1 )
```

`$driver_strength`

`$driver_strength` returns the current strength contribution of a specific driver to the strength of the signal.

Syntax

```
$driver_strength(signal_name, driver_index)
```

Where `signal_name` is the name of the signal and `driver_index` is an integer value between 0 and N-1, where N is the total number of drivers contributing to the signal value. The strength value is returned as two strengths, Bits 5-3 for `strength0` and Bits 2-0 for `strength1` (see IEEE 1364-1995 Verilog HDL sections 7.10 and 7.11).

If the value returned is 0 or 1, `strength0` returns the high-end of the strength range and `strength1` returns the low-end of the strength range. Otherwise, the strengths of both `strength0` and `strength1` are defined as shown in the following table.

Strength Value Mapping

strength0									strength1									
Bits	7	6	5	4	3	2	1	0		0	1	2	3	4	5	6	7	Bits
	Su0	St0	Pu0	La0	We0	Me0	Sm0	HiZ0		HiZ1	Sm1	Me1	We1	La1	Pu1	St1	Su1	
B5	1	1	1	1	0	0	0	0		0	0	0	0	1	1	1	1	B2
B4	1	1	0	0	1	1	0	0		0	0	1	1	0	0	1	1	B1
B3	1	0	1	0	1	0	1	0		0	1	0	1	0	1	0	1	B0

Example

```
value = $driver_strength(d,i);
```

`driver_update`

The status of drivers for a signal can be monitored with the event detection keyword `driver_update`. It is used in conjunction with the event detection operator `@` to detect updates to any of the drivers of the signal.

Syntax

```
event_name@(driver_update driver_name)
```

Example

```
always @(driver_update signal_name)
statement;
```

causes the `statement` to execute any time a driver of the signal `signal_name` is updated. Here, an update is defined as the addition of a new pending value to the driver. This is true whether or not there is a change in the resolved value of the signal.

Verilog-A and Verilog-AMS, and the Simulator

This topic describes how to access information related to the simulator function as well as provide information to the simulator to control or support the simulator.

Environment Parameter Functions

The environment parameter functions return simulator environment information.

The temperature Function

The temperature function, `$temperature()`, returns the ambient temperature of the circuit in Kelvin. The function has no arguments.

Syntax

```
$temperature[ ( ) ]
```

Example

```
DevTemp = $temperature;
```

The abstime Function

The absolute time function, `$abstime`, returns the simulation time, in seconds.

Syntax

```
$abstime
```

Example

```
simTime = $abstime;
```

The realtime Function

The realtime function, `$realtime`, returns the simulation time in seconds.

Syntax

```
$realtime[ ( ) ]
```

Example

```
CurTimeIn_mS = $realtime();
```

The Thermal Voltage Function

The thermal voltage function, `$vt`, returns the thermal voltage (kT/q) at the circuit's ambient temperature. Optionally, a temperature (in Kelvin) can be supplied and the thermal voltage returned is calculated at this temperature.

Syntax

```
$vt[( temperature_expression )]
```

Example

```
DevVth = $vt(Tnom + `P_CELSIUS0); // Tnom in C
```

 **Note**
The macro `P_CELSIUS0`, defined in the `constants.vams` header file, provides a convenient way to offset temperatures.

Controlling Simulator Actions

Verilog-A supports several functions to allow the model code to influence the simulation flow.

Bounding the Time Step

The bound step function, `$bound_step`, places a bound on the size of the next time step. The simulator may still choose to select a smaller time step but `$bound_step` will restrict the maximum step that will be used. The function has no return value.

Syntax

```
$bound_step( expression );
```

where *expression* is a required argument and sets the maximum time step (in seconds) that the simulator will take.

Example

```
$bound_step(maxTimeStep);
```

Announcing Discontinuities

The discontinuity function, `$discontinuity`, provides information about discontinuities in the module. The function has no return value.

Discontinuities can cause convergence problems for simulators and should be avoided when possible. Filter functions such as `transition()`, `limexp()`, and others can be used to smooth behavior of discontinuous functions. It is not necessary to use the `$discontinuity` function to declare discontinuities caused by switch branches and built-in system functions.

Syntax

```
$discontinuity[( constant_expression )];
```

where *constant_expression* is an optional argument that indicates the degree of the discontinuity. That is, `$discontinuity(i)` implies a discontinuity in the *i*'th derivative of the constitutive equation taken with respect to the signal value or time; *i* must be non-negative.

Example

```
@(cross(V(input, output))  
  $discontinuity(1); // Declare a discontinuity in slope
```

Analysis Dependent Functions

The analysis dependent functions interact with the simulator based on the analysis type.

Analysis Function

The analysis function, `analysis()`, provides a way to test the current analysis. The function accepts a single string or a list of strings as an argument and returns true (1) if any argument matches the current analysis type or false (0) if no matches are found.

Syntax

```
analysis(analysis_list)
```

The analysis list is not predefined but is set by the simulator. Simulators typically support the analysis types defined by SPICE, see the following table [Types of Analyses](#). If a type is unknown, the simulator returns no match. The return codes for analysis functions are summarized in the next table below, [Analysis Function Return Codes](#).

Types of Analyses

Name	Description of Analysis
"ac"	SPICE .AC analysis
"dc"	SPICE .OP (operation point) or DC
"noise"	SPICE .NOISE analysis
"tran"	SPICE .TRAN transient analysis
"ic"	SPICE .IC initial condition analysis which precedes a transient analysis
"static"	Equilibrium point analysis. Examples are DC analysis and other analyses that use a preceding DC analysis, such as AC or noise.
"nodeset"	Phase during static calculation where nodesets are forced

Analysis Function Return Codes

Analysis	Argument	DC	TRAN OP TRAN	AC OP AC	NOISE OP AC
First part of "static"	"nodeset"	1	1 0	1 0	1 0
Initial DC state	"static"	1	1 0	1 0	1 0
Initial condition	"ic"	0	1 0	0 0	0 0
DC	"dc"	1	0 0	0 0	0 0
Transient	"tran"	0	1 1	0 0	0 0
Small-signal	"ac"	0	0 0	1 1	0 0
Noise	"noise"	0	0 0	0 0	1 1

Example

```
if (analysis("ic"))
    vj = 0.7;
```

AC Stimulus Function

The AC stimulus function, `ac_stim()`, produces a sinusoidal stimulus for use during a small-signal analysis. During large-signal analyses such as DC and transient, the AC stimulus function returns zero (0). The small-signal analysis name depends on the simulator, but the default value is "ac".

If the small-signal analysis matches the analysis name, the source is activated with a magnitude of `mag` (default 1.0) and phase of `phase` (default 0.0, in radians).

Syntax

```
ac_stim([ analysis_name [, mag [, phase ]]])
```

Noise Functions

A variety of functions provide a way to easily support noise modeling for small-signal analyses. Noise is not contributed for transient analyses. In these cases, use the `$random` system task to contribute noise.

White Noise Function

White noise processes are completely uncorrelated with any previous or future values, and are therefore frequency-independent.

Syntax

```
white_noise( pwr [, name ])
```

generates a frequency-independent noise of power `pwr`.

The optional name labels the noise contribution so that it can be grouped with other noise contributions of the same name in the same module when a noise contribution summary is produced.

Example

```
I(n1, n2) <+ V(n1, n2) / R + white_noise(4 * `P_K * $temperature / R, "thermal");
```

Flicker Noise Function

The flicker noise function, `flicker_noise()`, models flicker noise processes.

Syntax

```
flicker_noise( pwr , exp [, name ])
```

generates a frequency-dependent noise of power *pwr* at 1 Hz which varies in proportion to the expression $1/f$ exp.

The optional name labels the noise contribution so that it can be grouped with other noise contributions of the same name in the same module when a noise contribution summary is produced.

Example

```
I(n1, n2) <+ flicker_noise(KF * pow(abs(I(n1,n2))), AF), 1.0, "flicker");
```

Noise Table Function

The noise table function, `noise_table()`, provides a means to introduce noise via a piecewise linear function of frequency.

Syntax

```
noise_table( vector [, name ] )
```

where

vector contains pairs of real numbers such that the first number of each pair is frequency (in Hz) and the second is the noise power. The pairs must be specified in ascending frequencies. The `noise_table()` function will linearly interpolate between number pairs in order to compute the power spectral density at each frequency.

name is optional and labels the noise contribution so that it can be grouped with other noise contributions of the same name in the same module when a noise contribution summary is produced.

Example

```
I(n1, n2) <+ noise_table({1,0.1, 100,0.2, 1e5,0.24}, "surface");
```

System Tasks and I/O Functions

This topic lists the various system tasks and functions available to the user to access simulator analysis information and shows the usage. System functions provide access to system level tasks as well as access to simulator information. See the following sections for details:

- [File Input/Output Operations](#)
- [Display Output Operations](#)
- [Simulator Control Operations](#)

The \$param_given Function

The parameter given function, `$param_given()`, can be used to test whether a parameter value was obtained from the default value in its declaration statement or if that value was overridden by a value passed from the netlist. The `$param_given()` function takes a single, required argument, the parameter identifier. The return value is one (1) if the parameter was overridden by a module instance parameter value assignment and zero (0) otherwise.

Syntax

```
$param_given( param_identifier )
```

where `param_identifier` is the name of a module parameter.

Example

In this example, if the netlist sets the value of `vth0`, then the variable `BSIM3vth0` is set to this value. Otherwise the `BSIM3vth0` is set to either 0.7 or -0.7 (depending on the value of `BSIM3type`).

```
if ($param_given(vth0))
    BSIM3vth0 = vth0;
else
    BSIM3vth0 = (BSIM3type == `NMOS) ? 0.7 : -0.7;
```

The \$table_model Function

The interpolation function, `$table_model()`, allows the module to approximate the behavior of a system by interpolating between user-supplied data points. The user provides a dataset of points ($x_{i1}, x_{i2}, \dots, x_{iN}, y_i$) such that $f(x_{i1}, x_{i2}, \dots, x_{iN}) = y_i$, where f is the model function and N is the number of independent variables of the model. These data points are stored in a text file and are accessed during the analysis by the Verilog-A module.

The interpolation algorithm then approximates the true model behavior at any point in the domain of the sampled data. Data points outside of the sampled domain will be approximated via extrapolation of the data within the domain. Extrapolated data can be inaccurate and should be avoided.

The Verilog-A algorithm is a piecewise-linear interpolation for the `$table_model()` function. However, higher-order interpolation algorithms may be provided in a future revision of the language.

The `$table_model()` system function has the same restrictions as analog operators. That is, it cannot be used inside of `if()`, `case()`, or `for()` statements unless these statements are controlled by `genvar`-constant expressions.

Syntax

```
$table_model( table_inputs , table_data_source , table_control_string );
```

where

`table_inputs` is an (optionally multi-dimensional) expression. For more information on the `table_inputs` argument, refer to [Table Model Inputs](#).

`table_data_source` is either a string indicating the name of the file holding the table data or the name of an array. For more information on the `table_data_source` argument, refer to [Table Data Source](#).

`table_control_string` is a two part string. The first character is an integer indicating the degrees of the spline interpolation (either 1 | 2 | 3). The second part of the control string consists of one or two characters (either C | L | E) indicating the type of extrapolation mode at the beginning and end of the data. For more information on the `table_control_string` argument, refer to [Table Control String](#).

The inputs to the `$table_model()` function are described in more detail in the following sections.

Table Model Inputs

The `table_inputs` are numerical expressions that are used as the independent model variables for the `$table_model()` function. They may be any valid expressions that can be assigned to an analog signal.

Table Data Source

The `table_data_source` argument specifies the source of sample points for the `$table_model()` function. The sample points may come from two sources: files and arrays. The file source indicates that the sample points be stored in a file, while the array source indicates that the data points are stored in a set of array variables. The user may choose the data source by either providing the file name of a file source or a set of array variables as an argument to the function.

The table is created when the `$table_model()` system function is called for the first time. Any changes to the `table_data_source` argument(s) of the `$table_model()` after the first call are quietly ignored (that is, the table model is not recreated). For a file source, each sample point of the table is represented as a sequence of numbers in the order of $X_{i1} X_{i2} \dots X_{iN} Y_i$, where X_{ik} is the coordinate of the sample point in k th dimension and Y_i is the model value at this sample point. Each sample point must be separated by a new line. The numbers in the sequence must be separated by one or more spaces or tabs. Comments may be inserted before or after any sample point; comments must begin with ``#'` and end with a new line.

The data file must be in text format only. The numbers must be real or integer. The sample points can be stored in the file in any order.

Example

The following example shows the contents of a table model files with two dimensions.

```
# datafile.tbl
# 2-D table model sample example of the function
#   f(x,y) = sqrt(x^2 + y^2)
#
# x y f(x,y)
-2 -2  2.828
-2 -1  2.236
-1 -1  1.414
 0  0  0
 0  1  1.0
 1  1  1.414
 1  2  2.236
 2  2  2.828
```

If the source of the data is an array, a set of one-dimensional arrays that contain the data points must be passed to the `$table_model()` function. The size of these arrays is determined by the number of sample points in the table, M . The data are stored in the arrays such that for the k th dimension of the i th sample point, `kth_dim_array_identifier[i`

$y_i = X_{ik}$ and such that for the i th sample point $output_array_identifier[i] = Y_i$.

Example

For the previous table model example, the same data would be provided to the function in an array as shown in the following code fragment.

```

@(initial_step) begin
    x[0]=-2; y[0]=-2; f_table[0]=2.828; // 0th sample point
    x[1]=-2; y[1]=-1; f_table[1]=2.236; // 1st sample point
    x[2]=-1; y[2]=-1; f_table[2]=1.414; // 2nd sample point
    x[3]=-0; y[3]= 0; f_table[3]=0;
    x[4]=-0; y[4]=-1; f_table[4]=1;
    x[5]=-0; y[5]=-1; f_table[5]=1.414;
    x[6]= 1; y[6]= 2; f_table[6]=2.236;
    x[7]= 2; y[7]= 2; f_table[7]=2.828;
end
    
```

Table Control String

The control string provides information on how the model should interpolate and extrapolate the table data. The control string consists of sub-strings for each dimension. Each sub-string may contain one character indicating the degree of the spine interpolation and an additional one or two characters indicating the type of extrapolation method to be used.

Table Interpolation Degree

The degree character is an integer between 1 and 3 representing the degrees of splines to be used for the interpolation. If not given, a degree of 1 (linear) is assumed. The following table shows the possible settings.

Table Interpolation Character	Interpolation Character Description
1	Linear spline (degree 1)
2	Quadratic spline (degree 2)
3	Cubic spline (degree 3)

Extrapolation Control String

The extrapolation control string is used to control the algorithm to extrapolate beyond the supplied data domain. The string may contain one or two extrapolation method characters. The extrapolation method determines the behavior of the table model when the point to be evaluated is beyond the domain of the user provided sample points. The Clamp extrapolation method, specified with the character C, uses a constant value from the last data point to extend the model. The Linear extrapolation method, specified with the character L, uses piecewise linear interpolation to estimate the requested point. The user may also disable extrapolation by setting the Error extrapolation method using the character E. In this case, an extrapolation error is reported if the `$table_model()` function is requested to evaluate a point beyond the interpolation region. The following table summarizes these options.

Table Extrapolation Character	Extrapolation Character Description
C	Clamp extrapolation
L	Linear extrapolation (default)
E	Error condition

For each dimension of the table, users may use up to two extrapolation method characters to specify the extrapolation method used for each end of the data set. When no extrapolation method character is supplied, the Linear extrapolation method will be used for both ends as default behavior. When a single extrapolation method character is supplied, the specified extrapolation method will be used for both ends of the data set. When two extrapolation method characters are supplied, the first character specifies the extrapolation method used for the end with the lower coordinate value and the second character specifies the extrapolation method for the end with the higher coordinate value. The following table illustrates some control strings and their interpretation.

Control String	Interpretation
"1LE,2EC"	1st dimension linear interpolation, linear extrapolation on left, error on extrapolation to right 2nd dimension quadratic interpolation, error on extrapolation to left, clamp on extrapolation to right
""	Linear interpolation, Linear extrapolation to left and right
,2	1st dimension linear interpolation, 2nd dimension quadratic interpolation, linear extrapolation to left and right
"3,1"	1st dimension cubic interpolation, 2nd dimension linear interpolation, linear extrapolation to left and right

Examples

In the first example, the data from the table defined earlier is contributed across the ports. The data in both dimensions is linearly extrapolated at both ends of the data.

```
module table_resistor (n1, n2);
```

```

electrical n1, n2;
  analog begin
    I(n1, n2) <+ $table_model (V(n1), V(n2), "datafile.tbl", "1L,1L");
  end
endmodule

```

In the second example, the same information is supplied within the module using the array method.

```

module user_table(n1, n2);
  electrical n1, n2;
  real x[0:7], y[0:7], f_table[0:7];
  analog begin
    @(initial_step) begin
      x[0]=-2; y[0]=-2; f_table[0]=2.828; // 0th sample point
      x[1]=-2; y[1]=-1; f_table[1]=2.236; // 1st sample point
      x[2]=-1; y[2]=-1; f_table[2]=1.414; // 2nd sample point
      x[3]=-0; y[3]= 0; f_table[3]=0;
      x[4]=-0; y[4]=-1; f_table[4]=1;
      x[5]=-0; y[5]=-1; f_table[5]=1.414;
      x[6]= 1; y[6]= 2; f_table[6]=2.236;
      x[7]= 2; y[7]= 2; f_table[7]=2.828;
    end
    I(a, b) <+ $table_model (V(n1), V(n2), x, y, f_table, "1L,1L");
  end
endmodule}}

```

File Input/Output Operations

There are several functions to provide reading and writing to files on the operating system. `$fopen()` opens a file for output while `$fclose()` closes the file. `$fstrobe()`, `$fdisplay`, and `$fwrite()` provide functions to write to the file.

The `$fopen` Function

The file open function, `$fopen()`, returns a value whose bits indicate a corresponding channel available for writing. `$fopen()` opens the file specified as an argument and returns the next available 32-bit multichannel descriptor, which is unique for the file. If the file could not be found or opened for writing, it returns 0.

The multichannel descriptor can be considered to be a set of 32 flags, where each flag represents a single output channel. The least significant bit (bit 0) always represents standard output, also called channel 0, while the other bits represent channels which have been opened by `$fopen()`.

The first call to `$fopen()` opens channel 1 and returns a value of 2 (bit 1 of the descriptor is set). The next call to `$fopen()` opens channel 2 and returns a value of 4 (bit 2 of the descriptor is set). Subsequent calls open channels 3,

4, 5, etc. and return values of 8, 16, 32, etc. A channel number corresponds to a single bit in the multichannel descriptor. Up to 32 channels may be opened.

Syntax

```
multi_channel_descriptor = $fopen( file_name );
```

where multi_channel_descriptor is an integer value and file_name is the name of the file to be opened.

The \$fclose Function

The file close function, `$fclose()`, closes the specified channel in the multichannel descriptor. Further output to the closed channel is no longer allowed. The `$fopen()` function reuses channels which have been closed.

Syntax

```
$fclose( multi_channel_descriptor );
```

where multi_channel_descriptor is an integer value representing the channel(s) to be closed.

The \$fstrobe Function

The file strobe function, `$fstrobe()`, writes data to the channel(s) specified in the multichannel descriptor.

Syntax

```
$fstrobe(multi_channel_descriptor [, list_of_arguments ]);
```

where multi_channel_descriptor represents one or more opened files and list_of_arguments is an optional, comma separated list of quoted strings or expressions. The arguments for list_of_arguments are the same as those available

for the `$strobe()` function argument.

Example

```
integer multi_ch_desc1, multi_ch_desc2, data_value;
@(initial_step) begin
    multi_ch_desc1 = $fopen("data1.txt");
    multi_ch_desc2 = $fopen("data2.txt");
    data_value = 1;
end

$fstrobe(multi_ch_desc1 | multi_ch_desc2, "Write value %d to both data1.txt and data2.txt", data_value) ;
```

The \$fdisplay Function

The file display function, `$fdisplay()`, writes data to the channel(s) specified in the multichannel descriptor. It provides the same capability as the `$fstrobe()` function.

Syntax

```
$fdisplay( multi_channel_descriptor [, list_of_arguments ]);
```

where `multi_channel_descriptor` represents one or more opened files and `list_of_arguments` is an optional, comma separated list of quoted strings or expressions. The arguments for `list_of_arguments` are the same as those available for the `$strobe` argument.

The \$fwrite Function

The file write function, `$fwrite()`, writes data to the channel(s) specified in the multichannel descriptor. It provides the same capability as the `$fstrobe()` function but without the newline character.

Syntax

```
$fwrite( multi_channel_descriptor [, list_of_arguments ] );
```

where `multi_channel_descriptor` represents one or more opened files and `list_of_arguments` is an optional, comma separated list of quoted strings or expressions. The arguments for `list_of_arguments` are the same as those available for the `$strobe()` function argument.

Display Output Operations

There are several functions available to display information to the user during a simulation. Each uses the same format specification but has slightly different modes of operation.

The \$strobe Function

The strobe function, `$strobe()`, displays its argument when the simulator has converged for all nodes at that time point. The `$strobe()` function always appends a new line to its output. The `$strobe()` function returns a newline character if no arguments are passed.

Syntax

```
$strobe( list_of_arguments );
```

where `list_of_arguments` is a comma separated list of quoted strings or expressions.

Examples

```
$strobe("The value of X is %g", X);
```

```
$strobe(); // print newline
```

The \$display Function

The display function, `$display()`, provides the same capability as the `$strobe` function but without the newline character.

Syntax

```
$display( list_of_arguments );
```

Example

```
$display("\n\nWarning: parameter X is %g, max allowed is %g\n\n", X, maxX);
```

Format Specification

The following tables describe the escape sequences available for the formatted output. The hierarchical format specifier, `%m`, does not take an argument. It will cause the display task to output the hierarchical name of the module, task, function, or named block which invoked the system task using the hierarchical format specifier. This feature can be used to determine which module generated a message, in the case where many modules are instantiated.

Escape Sequences

Sequence	Description
<code>\n</code>	newline character
<code>\t</code>	tab character
<code>\\</code>	<code>\</code> character
<code>\"</code>	" character
<code>\ddd</code>	character specified by 1-3 octal digits
<code>%%</code>	% character

Format Specifications

Specifier	Description
%h or %H	hexadecimal format
%d or %D	decimal format
%o or %O	octal format
%b or %B	binary format
%c or %C	ASCII format
%m or %M	hierarchical name format
%s or %S	string format

Format Specifications for Real Numbers

Specifier	Description
%e or %E	exponential format for real type
%f or %F	decimal format for real type
%g or %G	decimal or exponential format for real type using format that results in shorter printed output

Simulator Control Operations

Simulator control functions provide a means to interrupt simulator execution.

The \$finish Simulator Control Operation

The finish task simulator control operation, `$finish`, forces the simulator to exit and optionally print a diagnostic message.

Syntax

```
$finish [ ( n ) ] ;
```

where *n* is an optional flag to either (0) print nothing, (1) print simulator time and location, or (2) print simulator time, location, and statistics. The default value is 1.

Example

```
if (myError)
  $finish(1);
```

The \$stop Simulator Control Operation

The stop simulator control option, `$stop`, suspends the simulator at the converged timepoint and optionally prints a diagnostic message.

Syntax

```
$stop [ ( n ) ];
```

where *n* is an optional flag to either (0) print nothing, (1) print simulator time and location, or (2) print simulator time, location, and statistics. The default value is 1.

Example

```
if (myError)
  $stop(1);
```

The Verilog-A and Verilog-AMS Preprocessor

Verilog-A provides a familiar set of language preprocessing directives for macro definitions, conditional compilation of

code, and file inclusion. Directives are preceded by the accent grave (`) character, which should not be confused with a single quote. The directives are:

```
`define
```

```
`else
```

```
`ifdef
```

```
`include
```

```
`resetall
```

```
`undef
```

Defining Macros

A macro is defined using the ``define` directive

```
`define name value
```

For example,

```
`define PI 3.14
```

defines a macro called `PI` which has the value 3.14. `PI` may now be used anywhere in the Verilog-A file after this definition. To use `PI`, the preprocessing directive character, accent grave (`), must precede it. For example,

```
V(p,n) <+ sin(2*`PI*freq*time);
```

results in the following code

```
V(p,n) <+ sin(2*3.14*freq*time);
```

The directive name must be a valid identifier. It must be a sequence of alpha-numeric characters and underscores with a leading alpha character. Existing directive names cannot be used. This includes Verilog-A, Verilog-AMS and Verilog-2001 directives. Examples of invalid macro definitions are:

```
`define undef 1 // existing Verilog-A directive - wrong!
```

```
`define 1PICO 1p // leading character invalid - wrong!
```

```
`define elsif 1 // Verilog 2001 directive - wrong!
```

Macro text may be presented on multiple lines by using the Verilog-A line continuation character, backslash(\), at the end of each line. The backslash must be the last character on the line. If white space is inserted after the continuation character then the system will not continue the line.

Macros may also be parameterized using an arbitrary number of arguments,

```
`define name(arg1,arg2,arg3...) value
```

For example,

```
`define SUM(A,B) A+B
```

defines a parameterized macro called `SUM` which may be subsequently used as

```
V(out) <+ `SUM(V(in1),V(in2))
```

Argument names must also be valid identifiers and are separated by commas. There can be no space between the name of the macro and the first parenthesis. If there is a space, then the parenthesis and all characters that follow it are taken to be part of the macro definition text.

Macros may be re-defined. Doing so will produce a compiler warning. They may also be undefined using the ``undef` directive:

```
`undef SUM
```

The ``undef` directive takes a single macro name as argument. Note that no directive character is used here. Using ``undef` on a macro that has not been defined results in a compiler warning.

All macros may be removed using the ``resetall` directive. This is not frequently used, as it effectively deletes all macros defined to this point in processing. The directive takes no arguments as

```
`resetall
```

Including Files

The ``include` directive allows the inclusion of one file in another.

```
`include " filename "
```

The ``include` directive accepts a single quoted string, a file name, as argument. If an absolute filename is given, the compiler looks for the referenced file. If a relative filename is given, the compiler first looks in the current working directory and then in the system include directory for the referenced file. In either case, if the file is found, its contents are inserted into the current file in place of the include directive. If the file is not found then the system issues an error message. The system include directory is given by

```
$HPEESOF_DIR/tiburon-da/veriloga/include
```

Most Verilog-A files begin by including `disciplines.vams` and `constants.vams` as

```
`include "disciplines.vams"  
`include "constants.vams"
```

The compiler finds these system include files in the system include directory above. Include directives may be nested to twenty levels deep.

Conditional Compilation

Code may be conditionally compiled using the ``ifdef-`else-`endif` preprocessor construct. For example,

```
`ifdef macro
statements
`else
statements
```

```
`endif}}
```

If the conditional macro is defined, then the first set of statements are compiled, else the second set of statements are compiled. Both the true and false branches of the conditional must consist of lexicographically correct Verilog-A code. Note that as in `undef`, the preprocessing directive character is not used in the condition.

The `else` clause is optional and the construct may be written as,

```
`ifdef macro
statements
`endif}}
```

The following example performs output only if the `DEBUG` macro has been defined.

```
`ifdef DEBUG
$strobe("Output Voltage:%e", V(out));
`endif
```

Predefined Macros

The system has a number of predefined macros. The first is mandated by the Verilog-A standard. The macro `__VAMS_ENABLE__` is defined and has value 1.

Verilog-AMS and Verilog 1364 1995/2001 Directives

Verilog-AMS and Verilog 1364 directives are not available in the system, but they are all flagged as reserved directives

for compatibility purposes. The directives are:

``default_discipline`

``celldefine`

``default_nettype`

``elsif`

``endcelldefine`

``ifndef`

``line`

``nounconnected_drive`

``timescale`

``unconnected_drive`

Defining a directive with one of the above names will result in a reserved directive error message.

Unsupported Directives

Verilog-A supports two additional directives, ``default_transition` and ``default_function_type_analog`. These directives are not supported in this release of the compiler.

Reserved Words in Verilog-A and Verilog-AMS

This topic lists the reserved Verilog-A keywords. It also includes Verilog-AMS and Verilog-2001 keywords which are reserved.

A	
abs	and
absdelay	asin
acos	asinh
acosh	assign
ac_stim	atan
always	atan2
analog	atanh
analysis	
B,C	
begin	casez
bound_step	ceil
branch	cmos
buf	connectrules
bufif0	cos
bufif1	cosh
case	cross
casex	
D	
ddt	disable
deassign	discipline
default	discontinuity

Advanced Design System 2008

defparam	driver_update
delay	
E	
edge	endnature
else	endprimitive
end	endspecify
endcase	endtable
endconnectrules	endtask
enddiscipline	event
endfunction	exclude
endmodule	exp
F,G,H	
floor	function
flow	generate
for	genvar
force	ground
forever	highz0
fork	highz1
from	hypot
I,J	
idt	initial_step
idtmod	inout
if	input
ifnone	integer
inf	join
initial	
L,M,N	
laplace_nd	min

Advanced Design System 2008

laplace_np	module
laplace_zd	nand
laplace_zp	nature
large	negedge
last_crossing	net_resolution
limexp	nmos
ln	noise_table
log	nor
macromodule	not
max	notif0
medium	notif1
O,P	
or	pow
output	primitive
parameter	pull0
pmos	pull1
posedge	pullup
potential	pulldown
R,S	
rcmos	sin
real	sinh
realtime	slew
reg	small
release	specify
repeat	specparam
rnmos	sqrt
rpmos	strobe
rtran	strong0
rtranif0	strong1
rtranif1	supply0

scalared	supply1
T	
table	tranif1
tan	transition
tanh	tri
task	tri0
temperature	tri1
time	triand
timer	trior
tran	trireg
tranif0	
V,W,X,Z	
vectored	wor
vt	wreal
wait	xnor
wand	xor
weak0	zi_nd
weak1	zi_np
while	zi_zd
white_noise	zi_zp
wire	

Unsupported Elements

The following table lists the unsupported Verilog-A keywords and functionality.

Unsupported Elements

Hierarchy:	Ordered parameter lists in hierarchical instantiation
	Hierarchical names, except for node.potential.abstol and node.flow.abstol, which are supported
	Derived natures
	The defparam statement
Functions:	Accessing variables defined in a function's parent module
Input / Output:	The %b format character
	The \ddd octal specification of a character
	Parameter-sized ports
	Enforcement of input, output, and inout
System tasks:	\$realtime scaled to the `timescale directive
	The %b, %o, and %h specifications
	\$monitor
	File operations

Standard Definitions

This topic lists the current values of the standard header files that are part of the distribution.

The disciplines.vams File

```

/*
Verilog-A definition of Natures and Disciplines
$RCSfile: disciplines.vams,v $ $Revision: 1.1 $ $Date: 2003/09/22 01:36:17 $
*/
`ifdef DISCIPLINES_VAMS
`else
`define DISCIPLINES_VAMS 1

discipline logic
domain discrete;
enddiscipline
/*
* Default absolute tolerances may be overridden by setting the
* appropriate _ABSTOL prior to including this file

```

```

*/
// Electrical
// Current in amperes
nature Current
units = "A";
access = I;
idt_nature = Charge;

`ifdef CURRENT_ABSTOL
abstol = `CURRENT_ABSTOL;
`else
abstol = 1e-12;
`endif
endnature

// Charge in coulombs
nature Charge
units = "coul";
access = Q;
ddt_nature = Current;
`ifdef CHARGE_ABSTOL
abstol = `CHARGE_ABSTOL;
`else
abstol = 1e-14;
`endif
endnature

// Potential in volts
nature Voltage
units = "V";
access = V;
idt_nature = Flux;
`ifdef VOLTAGE_ABSTOL
abstol = `VOLTAGE_ABSTOL;
`else
abstol = 1e-6;
`endif
endnature

// Flux in Webers
nature Flux
units = "Wb";
access = Phi;
ddt_nature = Voltage;
`ifdef FLUX_ABSTOL
abstol = `FLUX_ABSTOL;
`else
abstol = 1e-9;
`endif
endnature

// Conservative discipline
discipline electrical
potential Voltage;
flow Current;
enddiscipline

// Signal flow disciplines
discipline voltage
potential Voltage;
enddiscipline
discipline current
potential Current;
enddiscipline

// Magnetic
// Magnetomotive force in Ampere-Turns.
nature Magneto_Motive_Force

```

```

units = "A*turn";
access = MMF;
`ifdef MAGNETO_MOTIVE_FORCE_ABSTOL
abstol = `MAGNETO_MOTIVE_FORCE_ABSTOL;
`else
abstol = 1e-12;
`endif
endnature

// Conservative discipline
discipline magnetic
potential Magneto_Motive_Force;
flow Flux;
enddiscipline

// Thermal

// Temperature in Kelvin
nature Temperature
units = "K";
access = Temp;
`ifdef TEMPERATURE_ABSTOL
abstol = `TEMPERATURE_ABSTOL;
`else
abstol = 1e-4;
`endif
endnature

// Power in Watts
nature Power
units = "W";
access = Pwr;
`ifdef POWER_ABSTOL
abstol = `POWER_ABSTOL;
`else
abstol = 1e-9;
`endif
endnature

// Conservative discipline
discipline thermal
potential Temperature;
flow Power;
enddiscipline

// Kinematic
// Position in meters
nature Position
units = "m";
access = Pos;
ddt_nature = Velocity;
`ifdef POSITION_ABSTOL
abstol = `POSITION_ABSTOL;
`else
abstol = 1e-6;
`endif
endnature

// Velocity in meters per second
nature Velocity
units = "m/s";
access = Vel;
ddt_nature = Acceleration;
idt_nature = Position;
`ifdef VELOCITY_ABSTOL
abstol = `VELOCITY_ABSTOL;
`else
abstol = 1e-6;
`endif

```

```

endnature

// Acceleration in meters per second squared
nature Acceleration
units = "m/s^2";
access = Acc;
ddt_nature = Impulse;
idt_nature = Velocity;
`ifndef ACCELERATION_ABSTOL
abstol = `ACCELERATION_ABSTOL;
`else
abstol = 1e-6;
`endif
endnature

// Impulse in meters per second cubed
nature Impulse
units = "m/s^3";
access = Imp;
idt_nature = Acceleration;
`ifndef IMPULSE_ABSTOL
abstol = `IMPULSE_ABSTOL;
`else
abstol = 1e-6;
`endif
endnature

// Force in Newtons
nature Force
units = "N";
access = F;
`ifndef FORCE_ABSTOL
abstol = `FORCE_ABSTOL;
`else
abstol = 1e-6;
`endif
endnature

// Conservative disciplines
discipline kinematic
potential Position;
flow Force;
enddiscipline
discipline kinematic_v
potential Velocity;
flow Force;
enddiscipline

// Rotational

// Angle in radians
nature Angle
units = "rads";
access = Theta;
ddt_nature = Angular_Velocity;
`ifndef ANGLE_ABSTOL
abstol = `ANGLE_ABSTOL;
`else
abstol = 1e-6;
`endif
endnature

// Angular Velocity in radians per second
nature Angular_Velocity
units = "rads/s";
access = Omega;
ddt_nature = Angular_Acceleration;
idt_nature = Angle;
`ifndef ANGULAR_VELOCITY_ABSTOL

```

```

abstol = `ANGULAR_VELOCITY_ABSTOL;
`else
abstol = 1e-6;
`endif
endnature

// Angular acceleration in radians per second squared
nature Angular_Acceleration
units = "rads/s^2";
access = Alpha;
idt_nature = Angular_Velocity;
`ifdef ANGULAR_ACCELERATION_ABSTOL
abstol = `ANGULAR_ACCELERATION_ABSTOL;
`else
abstol = 1e-6;
`endif
endnature

// Torque in Newtons
nature Angular_Force
units = "N*m";
access = Tau;
`ifdef ANGULAR_FORCE_ABSTOL
abstol = `ANGULAR_FORCE_ABSTOL;
`else
abstol = 1e-6;
`endif
endnature

// Conservative disciplines
discipline rotational
potential Angle;
flow Angular_Force;
enddiscipline
discipline rotational_omega
potential Angular_Velocity;
flow Angular_Force;
enddiscipline

`endif

```

The constants.vams File

```

/*
Verilog-A definition of Mathematical and physical constants
$RCSfile: constants.vams,v $ $Revision: 1.1 $ $Date: 2003/09/22 01:36:17 $
*/
`ifndef CONSTANTS_VAMS
`else
`define CONSTANTS_VAMS 1
// M_ indicates a mathematical constant
`define M_E 2.7182818284590452354
`define M_LOG2E 1.4426950408889634074
`define M_LOG10E 0.43429448190325182765
`define M_LN2 0.69314718055994530942
`define M_LN10 2.30258509299404568402
`define M_PI 3.14159265358979323846
`define M_TWO_PI 6.28318530717958647652

```

```

`define M_PI_2      1.57079632679489661923
`define M_PI_4      0.78539816339744830962
`define M_1_PI      0.31830988618379067154
`define M_2_PI      0.63661977236758134308
`define M_2_SQRTPI  1.12837916709551257390
`define M_SQRT2     1.41421356237309504880
`define M_SQRT1_2   0.70710678118654752440

// P_ indicates a physical constant

// charge of electron in coulombs
`define P_Q 1.6021918e-19

// speed of light in vacuum in meters/sec
`define P_C 2.997924562e8

// Boltzman's constant in joules/kelvin
`define P_K 1.3806226e-23

// Plank's constant in joules*sec
`define P_H 6.6260755e-34

// permittivity of vacuum in farads/meter
`define P_EPS0 8.85418792394420013968e-12

// permeability of vacuum in henrys/meter
`define P_U0 (4.0e-7 * `M_PI)

// zero celsius in kelvin
`define P_CELSIUS0 273.15

`endif

```

The compact.vams File

```

/*
Copyright 2002, 2003 Tiburon Design Automation, Inc. All rights reserved.
This software has been provided pursuant to a License Agreement
containing restrictions on its use. This software contains
valuable trade secrets and proprietary information of
Tiburon Design Automation, Inc. and is protected by law. It may
not be copied or distributed in any form or medium, disclosed
to third parties, reverse engineered or used in any manner not
provided for in said License Agreement except with the prior
written authorization from Tiburon Design Automation, Inc.

Useful, common macro definitions and utilities
$RCSfile: compact.vams,v $ $Revision: 1.1 $ $Date: 2003/09/22 01:36:17 $
*/

`ifndef COMPACT_VAMS
`else
`define COMPACT_VAMS 1
// SPICE-specific different values:
`define SPICE_GMIN 1.0e-12
`define SPICE_K 1.3806226e-23
`define SPICE_Q 1.6021918e-19

```

```

`define LARGE_REAL 1.0e38
`define MIN_CONDUCTANCE 1.0e-3
`define DEFAULT_TNOM 27

/* NOT_GIVEN are codes that are used to detect if a
 * parameter value has been passed (future extensions
 * to Verilog-A should make this obsolete). */
`define NOT_GIVEN -9.9999e-99
`define INT_NOT_GIVEN -9999999

`define N_MINLOG 1.0e-38
`define MAX_EXP 5.834617425e14
`define MIN_EXP 1.713908431e-15
`define EXP_THRESHOLD 34.0

`define TRUE 1
`define FALSE 0

/* Useful macro for setting Type
   example: `SET_TYPE(P_TYPE, N_TYPE, Type);
   will set variable Type          */
`define SET_TYPE(n, p, Type) Type = 1; if (p == 1) Type = -1; if (n == 1) Type = 1

/* Print out value:
   example: `DEBUG_STROBE("myVariable", myVariable); */
`define DEBUG_STROBE(xName, x) \
`ifdef DEBUG \
    $strobe("\n%s = %g", xName, 1.0*x) \
`else \
    $strobe("") \
`endif
`endif

```

Condensed Reference

Verilog-A is an analog hardware description language standard from Open Verilog International (www.ovi.org). It can be used to describe analog circuit behavior at a wide range of abstraction from behavioral models of circuits to compact transistor model descriptions. The Verilog-A source code is compiled automatically, if necessary, during a simulation. The netlist format follows the conventional ADS netlisting scheme. Modules whose names match ADS components will automatically override the built-in model description.

Verilog-A Module Template

```

`include "disciplines.vams" // Natures and disciplines
`include "constants.vams" // Common physical and math constants
module myModel(port1, port2);
    electrical port1, port2;
    parameter real input1= 1.0 from [0:inf];
    parameter integer input2 = 1 from [-1:1] exclude 0;

```

```

real X;
// this is a comment
/* this is a
 * comment block */
analog begin
  @( initial_step ) begin
    // performed at the first timestep of an analysis
  end
  if (input2 > 0) begin
    $strobe("input2 is positive",input1)
    // module behavioral description
    V(port1, port2) <+ I(port1, port2) * input1;
  end
  @( final_step ) begin
    // performed at the last time step of an analysis
  end
end
endmodule

```

Data Types

Data type	Description
integer	Discrete numerical type integer [integer_name {, integer_name};
real	Continuous numerical type real[real_name {, real_name...};
parameter	Attribute that indicates data type is determined at module instantiation. parameter parameter_type param_name = default_value [from [range_begin:range_end] [exclude exclude_value];

Analog Operators and Filters

Analog operators and filters maintain memory states of past behavior. They can not be used in an analog function.

Operator	Function
Time derivative	The ddt operator computes the time derivative of its argument. ddt(expr)
Time integral	The idt operator computes the time-integral of its argument. idt(expr, [ic [, assert [, abstol]]])

<p>Linear time delay</p>	<p>absdelay() implements the absolute transport delay for continuous waveform. absdelay(input, time_delay [, maxdelay])</p>
<p>Discrete waveform filters</p>	<p>The transition filter smooths out piecewise linear waveforms. transition(expr [, td [, rise_time [, fall_time [, time_tol]]]) The slew analog operator bounds the rate of change (slope) of the waveform. slew(expr [, max_pos_slew_rate [, max_neg_slew_rate]]) The last_crossing() function returns a real value representing the simulation time when a signal expression last crossed zero. last_crossing(expr, direction)</p>
<p>Laplace transform filters</p>	<p>laplace_zd() implements the zero-denominator form of the Laplace transform filter. The laplace_np() implements the numerator-pole form of the Laplace transform filter. laplace_nd() implements the numerator-denominator form of the Laplace transform filter. laplace_zp() implements the zero-pole form of the Laplace transform filter. laplace_zp(expr, z, r)</p>
<p>Z-transform filters</p>	<p>The Z-transform filters implement linear discrete-time filters. Each filter uses a parameter T which specifies the filter's sampling period. The zeros argument may be represented as a null argument. The null argument is produced by two adjacent commas (,,) in the argument list. All Z-transform filters share three common arguments: T, t, and t0. T specifies the period of the filter, is mandatory, and must be positive. t specifies the transition time, is optional, and must be nonnegative. zi_zd() implements the zero-denominator form of the Z-transform filter. zi_np() implements the numerator-pole form of the Z-transform filter. zi_nd() implements the numerator-denominator form of the Z-transform filter. zi_zp() implements the zero-pole form of the Z-transform filter. zi_zp(expr , z , r , T [, t [, t0]])</p>
<p>limexp</p>	<p>Limits exponential argument change from one iteration to the next. limexp(arg)</p>

Mathematical Functions

Function	Description	Domain	Return value
$\ln()$	natural log	$x > 0$	real
$\log(x)$	log base 10	$x > 0$	real
$\exp(x)$	exponential	$x < 80$	real
$\text{sqrt}(x)$	square root	$x \geq 0$	real
$\text{min}(x,y)$	minimum of x and y	all x, y	if either is real, returns real, otherwise returns the type of x,y.
$\text{max}(x,y)$	maximum of x and y	all x, y	if either is real, returns real, otherwise returns the type of x,y.
$\text{abs}(x)$	absolute value	all x	same as x
$\text{pow}(x,y)$	x^y	if $x \geq 0$, all y; if $x < 0$, $\text{int}(y)$	real
$\text{floor}(x)$	floor	all x	real
$\text{ceil}(x)$	ceiling	all x	real

Transcendental Functions

Function	Description	Domain
$\sin(x)$	sine	all x
$\cos(x)$	cosine	all x
$\tan(x)$	tangent	$x \neq n(\pi/2)$, n is odd
$\text{asin}(x)$	arc-sine	$-1 \leq x \leq 1$
$\text{acos}(x)$	arc-cosine	$-1 \leq x \leq 1$
$\text{atan}(x)$	arc-tangent	all x
$\text{atan2}(x,y)$	arc-tangent of x/y	all x, all y
$\text{hypot}(x,y)$	$\text{sqrt}(x^2 + y^2)$	all x, all y
$\sinh(x)$	hyperbolic sine	$x < 80$
$\cosh(x)$	hyperbolic cosine	$x < 80$
$\tanh(x)$	hyperbolic tangent	all x

asinh(x)	arc-hyperbolic sine	all x
acosh(x)	arc-hyperbolic cosine	$x \geq 1$
atanh(x)	arch-hyperbolic tangent	$-1 \leq x \leq 1$

AC Analysis Stimuli

Function	Description
AC Stimulus	The AC stimulus function produces a sinusoidal stimulus for use during a small-signal analysis. ac_stim([analysis_name [, mag [, phase]]])

Noise Functions

Function	Description
White Noise	Generates a frequency-independent noise of power pwr. white_noise(pwr [, name])
Flicker Noise	Generates a frequency-dependent noise of power pwr at 1 Hz which varies in proportion to the expression 1/fexp. flicker_noise(pwr, exp [, name])
Noise Table	Define noise via a piecewise linear function of frequency. Vector is frequency, pwr pairs in ascending frequencies. noise_table(vector [, name])

Analog Events

Function	Description
Initial Step	Event trigger at initial step. @(initial_step [(list_of_analyses)])
Final Step	Event trigger at final step. @(final_step [(list_of_analyses)])
Cross	Zero crossing threshold detection. cross(expr [, dir [, time_tol [, expr_tol]]]);
Timer	Generate analog event at specific time. timer (start_time [, period [, time_tol]]);

Timestep Control

Function	Purpose
\$bound_step	Controls the maximum time step the simulator will take during a transient simulation. \$bound_step(expression);
\$discontinuity	Provides the simulator information about known discontinuities to provide help for simulator convergence algorithms. \$discontinuity [(constant_expression)];

Input/Output Functions

Function	Return Value
\$strobe	Display simulation data when the simulator has converged on a solution for all nodes using a printf() style format. \$strobe(args)
\$fopen	Open a file for writing and assign it to an associated channel. multi-channel_desc = \$fopen("file");
\$fclose	Close a file from a previously opened channel(s). \$fclose(multi-channel_desc);
\$fstrobe \$fdisplay \$fwrite	Write simulation data to an opened channel(s) when the simulator has converged. Follows format for \$strobe. \$fstrobe(multi-channel_desc, "info to be written");

Simulator Environment Functions

The environment parameter functions return simulator environment information.

Function	Return Value
\$temperature	Return circuit ambient temperature in Kelvin. \$temperature
\$abstime	Return absolute time in seconds. \$abstime
\$vt	\$vt can optionally have Temperature (in Kelvin) as an

	input argument and returns the thermal voltage (kT/q) at the given temperature. \$vt without the optional input temperature argument returns the thermal voltage using \$temperature. \$vt[(Temperature)]
\$analysis	Returns true (1) if current analysis matches any one of the passed arguments. \$analysis(str {, str})

Module Hierarchy

Structural statements are used inside the module block but cannot be used inside the analog block.

```
module_or_primitive #({.param1(expr){, .param2(expr)}) instance_name ({node {, node}});
```

Example

```
my_src #(.fstart(100), .ramp(z));
```